

Simulink[®] Real-Time[™]

I/O Reference



MATLAB[®]&SIMULINK[®]

R2016a



How to Contact MathWorks



Latest news: www.mathworks.com
Sales and services: www.mathworks.com/sales_and_services
User community: www.mathworks.com/matlabcentral
Technical support: www.mathworks.com/support/contact_us



Phone: 508-647-7000



The MathWorks, Inc.
3 Apple Hill Drive
Natick, MA 01760-2098

Simulink[®] *Real-Time*[™] *I/O Reference*

© COPYRIGHT 2000–2016 by The MathWorks, Inc.

The software described in this document is furnished under a license agreement. The software may be used or copied only under the terms of the license agreement. No part of this manual may be photocopied or reproduced in any form without prior written consent from The MathWorks, Inc.

FEDERAL ACQUISITION: This provision applies to all acquisitions of the Program and Documentation by, for, or through the federal government of the United States. By accepting delivery of the Program or Documentation, the government hereby agrees that this software or documentation qualifies as commercial computer software or commercial computer software documentation as such terms are used or defined in FAR 12.212, DFARS Part 227.72, and DFARS 252.227-7014. Accordingly, the terms and conditions of this Agreement and only those rights specified in this Agreement, shall pertain to and govern the use, modification, reproduction, release, performance, display, and disclosure of the Program and Documentation by the federal government (or other entity acquiring for or through the federal government) and shall supersede any conflicting contractual terms or conditions. If this License fails to meet the government's needs or is inconsistent in any respect with federal procurement law, the government agrees to return the Program and Documentation, unused, to The MathWorks, Inc.

Trademarks

MATLAB and Simulink are registered trademarks of The MathWorks, Inc. See www.mathworks.com/trademarks for a list of additional trademarks. Other product or brand names may be trademarks or registered trademarks of their respective holders.

Patents

MathWorks products are protected by one or more U.S. patents. Please see www.mathworks.com/patents for more information.

Revision History

November 2000	Online only	Revised for Version 1.1 (Release 12)
June 2001	Online only	Revised for Version 1.2 (Release 12.1)
September 2001	Online only	Revised for Version 1.3 (Release 12.1+)
July 2002	Online only	Revised for Version 2 (Release 13)
September 2002	Online only	Revised for Version 2.0.1 (Release 13)
September 2003	Online only	Revised for Version 2.0.1 (Release 13SPI)
June 2004	Online only	Revised for Version 2.5 (Release 14)
August 2004	Online only	Revised for Version 2.6 (Release 14+)
October 2004	Online only	Revised for Version 2.6.1 (Release 14SP1)
November 2004	Online only	Revised for Version 2.7 (Release 14SP1+)
March 2005	Online only	Revised for Version 2.7.2 (Release 14SP2)
September 2005	Online only	Revised for Version 2.8 (Release 14SP3)
March 2006	Online only	Revised for Version 2.9 (Release 2006a)
May 2006	Online only	Revised for Version 3.0 (Release 2006a+)
September 2006	Online only	Revised for Version 3.1 (Release 2006b)
March 2007	Online only	Revised for Version 3.2 (Release 2007a)
September 2007	Online only	Revised for Version 3.3 (Release 2007b)
March 2008	Online only	Revised for Version 3.4 (Release 2008a)
October 2008	Online only	Revised for Version 4.0 (Release 2008b)
March 2009	Online only	Revised for Version 4.1 (Release 2009a)
September 2009	Online only	Revised for Version 4.2 (Release 2009b)
March 2010	Online only	Revised for Version 4.3 (Release 2010a)
September 2010	Online only	Revised for Version 4.4 (Release 2010b)
April 2011	Online only	Revised for Version 5.0 (Release 2011a)
September 2011	Online only	Revised for Version 5.1 (Release 2011b)
March 2012	Online only	Revised for Version 5.2 (Release 2012a)
September 2012	Online only	Revised for Version 5.3 (Release 2012b)
March 2013	Online only	Revised for Version 5.4 (Release 2013a)
September 2013	Online only	Revised for Version 5.5 (Release 2013b)
March 2014	Online only	Revised for Version 6.0 (Release 2014a)
October 2014	Online only	Revised for Version 6.1 (Release 2014b)
March 2015	Online only	Revised for Version 6.2 (Release 2015a)
September 2015	Online only	Revised for Version 6.3 (Release 2015b)
March 2016	Online only	Revised for Version 6.4 (Release 2016a)

Introduction, RS-232

Simulink Real-Time I/O Library

1

I/O Driver Blocks	1-2
Speedgoat I/O Modules	1-2
Third-Party Driver Blocks	1-2
I/O Driver Block Library	1-3
Memory-Mapped Devices	1-4
ISA Bus I/O Devices	1-4
PCI Bus I/O Devices	1-4
Simulink Real-Time I/O Driver Structures	1-5
Simulink Real-Time Support and SimState	1-7
PWM and FM Driver Block Notes	1-9
Driver Block Documentation	1-10
Add I/O Blocks to Simulink Model	1-11
Defining I/O Block Parameters	1-13

Serial Communications Support

2

RS-232 I/O Drivers	2-2
Internal Drivers	2-3
Serial Connections for RS-232	2-3

RS-232/422/485 Drivers (Composite)	2-5
Adding RS-232 Blocks	2-6
Building and Running the Real-Time Application (Composite)	2-10
RS-232/422/485 Simulink Block Reference	2-11

Serial Communications Support: Blocks

3

Serial Communications Support: Internal Blocks

A

CAN, Ethernet, EtherCAT

CAN I/O Support

4

CAN Basics	4-2
Simulink Real-Time CAN Library	4-2
Data Types	4-3
Sending and Receiving Remote Frames	4-4
Supported Softing Boards	4-6
CAN-AC2-PCI with SJA1000 Controller	4-6
CAN-AC2-104 with SJA1000 Controller	4-7
Model Execution Driven by CAN Messages	4-8
CAN-AC2-PCI	4-8
CAN-AC2-104 (PC/104)	4-9
Initialization and Termination CAN Messages	4-11

CAN Data Frames	4-13
Timeouts When Receiving CAN Messages	4-14

CAN I/O Blocks

5

CAN I/O FIFO Support

6

CAN FIFO Basics	6-2
FIFO Mode	6-2
FIFO Mode Drivers for CAN Boards from Softing	6-4
Acceptance Filters	6-8
CANdb DBC Format Databases	6-10
CAN FIFO Loopback Tests	6-11

CAN I/O FIFO Blocks

7

Model-Based Ethernet Communications Support

8

Model-Based Ethernet Communications	8-2
What Is Model-Based Ethernet Communications?	8-2
Ethernet Hardware	8-2
PCI Bus and Slot Numbers	8-3
MAC Addresses	8-3

Network Buffer Pointers	8-4
Filter Type and Filter Address Blocks	8-4
Execution Priority	8-4
Simulink Real-Time Ethernet Block Library	8-4

Ethernet Blocks

9

Network Buffer Library for Model-Based Ethernet Communications Support

10

Network Buffer Blocks	10-2
-----------------------------	------

Network Buffer Library Blocks

11

Model-Based EtherCAT Communications Support

12

Modeling EtherCAT Networks	12-2
Blocks and Tasks	12-2
Order of Network Events	12-3
 Install EtherCAT Network and Configuration	
Software	12-6
 EtherCAT Installation and Setup Requirements	12-7

Configure EtherCAT Network	12-8
Scan EtherCAT Network	12-8
Configure EtherCAT Master Node Data	12-9
Export and Save EtherCAT Configuration	12-14
Install EtherCAT Network for Execution	12-15
Configure EtherCAT Master Node Model	12-16
Configure EtherCAT Init Block	12-16
Configure EtherCAT PDO Receive Blocks	12-18
Configure EtherCAT PDO Transmit Blocks	12-18
Configure EtherCAT Model Configuration Parameters	12-19
Fixed-Step Size Derivation	12-21
EtherCAT Protocol Mapping	12-22
EtherCAT Configurator Component Mapping	12-23
Ethernet Chip Sets Compatible with EtherCAT	12-24
Intel Gigabit Ethernet Chip Sets	12-24
Intel Fast Ethernet (10/100) Chip Sets	12-26
EtherCAT Data Types	12-27
EtherCAT Init Block Error Values	12-28
EtherCAT Init Block DC Error Values	12-30

13

UDP

Real-Time UDP Communication Support

14

Using Real-Time UDP Communications	14-2
Low-Level Internet Protocol Library	14-3

Real-Time UDP Blocks

15

UDP I/O Support

16

UDP Transport Protocol	16-2
Two-Way Data Exchange Using UDP	16-5
UDP Communication Setup	16-10
UDP and Variable-Size Signals	16-11

17

Parallel Ports, PTP, SAE J1939, Shared Memory

Parallel Ports

18

Using Parallel Ports	18-2
Introduction	18-2
Using the Parallel Port as an Interrupt Source	18-3
Using Add-On Parallel Port Boards	18-4

Parallel Port Blocks

19

Precision Time Protocol

20

Precision Time Protocol	20-2
Synchronize Timestamps Across Data-Gathering Network	20-5
Data Acquisition and Data Analysis Example	
Description	20-17
Data Acquisition Application	20-17
Data Analysis Application	20-20
Precision Time Protocol Troubleshooting	20-24
Modeling	20-24

Accuracy	20-25
Faulty States	20-25

Prerequisites, Limitations, and Unsupported

Features	20-27
Prerequisites	20-27
Limitations	20-27
Unsupported Features	20-29

Precision Time Protocol Blocks

21

SAE J1939

22

SAE J1939 Blocks	22-2
------------------------	------

SAE J1939 Blocks

23

Shared Memory Support

24

Create GE Fanuc Shared Partitions	24-2
Initialize GE Fanuc Shared Nodes	24-4
GE Fanuc Shared Partition Structure	24-6
GE Fanuc Shared Node Initialization Structure	24-8
Board Mode	24-8

Board Interrupts	24-9
Board Node ID	24-11
GE Intelligent Platforms Shared Memory	24-13
Create GE Intelligent Platforms Shared Partitions	24-14
Initialize GE Intelligent Platforms Shared Nodes	24-17
GE Intelligent Platforms Shared Partition Structure	24-19
GE Intelligent Platforms Shared Node Initialization Structure	24-21
Board Interrupts	24-22
Create Curtiss-Wright Shared Partitions	24-24
Initialize Curtiss-Wright Shared Nodes	24-26
Curtiss-Wright Shared Partition Structure	24-27
Alignment Examples	24-30
Curtiss-Wright Shared Node Initialization Structure	24-32
Board Mode	24-32
Board Timeout	24-34
Board Data Filter	24-34
Virtual Paging	24-35
Board Interrupts	24-35

Video, XCP

Process Video Images Using Simulink Real-Time	25-2
USB Video Display on Development Computer	25-3

USB Video Display on Target Computer	25-4
Camera Link Camera Display on Development Computer	25-5
Camera Link Camera Display on Target Computer ..	25-7
Acquire Images from Camera Link Cameras	25-8
Camera Link Camera Triggering	25-9
Serial Camera Configuration	25-13
Install BitFlow Neon-CLB Support	25-15

Video Blocks

26

XCP Master Mode

27

XCP Master Mode	27-2
-----------------------	------

28

Adlink

29

BittWare

30

Running Models with BittWare Blocks	30-2
Model Notes	30-2
Frame Size, Sample Rate, and Sample Time Parameter	
Notes	30-4

BVM, Contec, Curtiss-Wright

31	BVM
-----------	------------

32	Contec
-----------	---------------

33	Curtiss-Wright Electronic Systems Blocks
-----------	---

Diamond, FlexRay

34	Diamond
-----------	----------------

35	Model-Based FlexRay Communications Support
-----------	---

Install FlexRay Network and Configuration Software	35-2
--	------

FlexRay Installation and Setup Requirements	35-3
---	------

Configure FlexRay Node for Signal Access	35-4
--	------

Create Busmirror Project for Signal Access	35-4
--	------

Select FlexRay Node for Signal Access	35-7
Refine FlexRay Node for Signal Access	35-7
Generate Project Code for Signal Access	35-10
Prepare FlexRay Network for Signal Access	35-15
Prepare FlexRay Model for Signal Access	35-16
Configure FlexRay Config Blocks for Signal Access . .	35-17
Configure FlexRay Write Frame Signals Blocks for Signal Access	35-19
Configure FlexRay Read Frame Signals Blocks for Signal Access	35-24
Configure FlexRay POC Status Blocks for Signal Access	35-26
Configure FlexRay Model Configuration Parameters for Signal Access	35-26
Configure FlexRay Node for PDU Access	35-29
Create Busmirror Project for PDU Access	35-29
Select FlexRay Node for PDU Access	35-32
Refine FlexRay Node for PDU Access	35-32
Generate Project Code for PDU Access	35-35
Prepare FlexRay Network for PDU Access	35-39
Prepare FlexRay Model for PDU Access	35-40
Configure FlexRay Config Blocks for PDU Access . . .	35-40
Configure FlexRay Pack PDU Blocks	35-42
Configure FlexRay Write PDU Blocks	35-45
Configure FlexRay Commit Frame Block for PDU Access	35-48
Configure FlexRay Read PDU Blocks	35-49
Configure FlexRay Unpack PDU Blocks	35-52
Configure FlexRay POC Status Blocks for PDU Access	35-54
Configure FlexRay Model Configuration Parameters for PDU Access	35-54
Configure FlexRay Node for Error Injection	35-57
Create Busmirror Project for Error Injection	35-57
Select FlexRay Node for Error Injection	35-60
Refine FlexRay Node for Error Injection	35-60
Generate Project Code for Error Injection	35-61

Prepare FlexRay Network for Error Injection	35-66
Prepare FlexRay Model for Error Injection	35-67
Configure FlexRay Config Blocks for Error Injection	35-69
Configure FlexRay Write Frame Signals Blocks for Error Injection	35-70
Configure FlexRay Read Frame Signals Blocks for Error Injection	35-75
Configure FlexRay Error Injection Blocks	35-77
Configure FlexRay POC Status Blocks for Error Injection	35-81
Configure FlexRay Model Configuration Parameters for Error Injection	35-81
Evaluate Clear from Bus Preconditions	35-84
Frame Triggering Assigned to Nonsynchronization Slot	35-84
Frame Triggering Assigned to Nonzero Buffer	35-84
FlexRay Troubleshooting	35-86
Model Configuration	35-86
Build and Download	35-86
Execution	35-87

36

37

General Standards, HUMUSOFT

38

PMC-ADADIO Basics	38-2
Adding A/D Blocks for Analog Input	38-4
Adding Enable Signal Blocks for Input Enable	38-6
Adding D/A Blocks for Analog Output	38-8
Interleaving Analog Input and Output Blocks	38-10
Using Multiple PMC-ADADIO Boards	38-12
Overview of Audio Systems	38-14

General Standards Blocks

39

HUMUSOFT Blocks

40

MathWorks, Measurement Computing, MIL-STD-1553, MPL

MathWorks

41

xPC TargetBox Support	41-2
xPC TargetBox I/O Options	41-3

Measurement Computing

42

MIL-STD-1553 Support

43

MIL-STD-1553 Support	43-2
MIL-STD-1553 Initialization	43-4
Remote Terminal Operation	43-5

Bus Controller Operation	43-7
Remote Terminal and Bus Controller Operation	43-9
Bus Monitor Operation	43-11

MPL

44

National Instruments

National Instruments Support

45

National Instruments Troubleshooting	45-2
---	-------------

National Instruments Blocks

46

NAII, Quanser, Real Time Devices

North Atlantic Industries, Inc.

47

Quanser

48

Real Time Devices

49

Sensoray, Speedgoat, Texas Instruments

Sensoray

50

Speedgoat Support

51

Speedgoat Real-Time Target Machines	51-2
Speedgoat I/O Modules	51-3
Speedgoat Communication Protocols	51-5

Speedgoat Blocks

52

UEI, Versallogic, Asynchronous Events

United Electronic Industries (UEI)

53

A/D Frame Acquisition	53-2
Specifying UEI Boards	53-3
Changing the Board Associated with the Block	53-3
Getting Information on a Specific Board	53-3
Analog Input Frame Driver Blocks	53-5
Introduction	53-5
Notes on Master and Slave Boards	53-5
Interrupt Numbers	53-6
IRQ Source Block	53-8
Example Models	53-8

**United Electronic Industries (UEI): Boards and
Blocks**

54

Versallogic: Board and Blocks

55

Asynchronous Events

56

Asynchronous Event Support	56-2
Adding an Asynchronous Event	56-2
Asynchronous Interrupt Examples	56-4

57

Utility Drivers, Target Management, Displays and Logging

Utility Blocks

58

Target Management, Display, and Logging
Blocks

59

Drivers No Longer Recommended for Use

Simulink Real-Time Drivers No Longer
Recommended for Use

60

Library of Drivers No Longer Recommended for Use .	60-2
Drivers No Longer Recommended	60-2
Drivers Updated	60-3
ACCES I/O Drivers No Longer Recommended for Use	60-4
Advantech Drivers No Longer Recommended for Use	60-7
Analogic Drivers No Longer Recommended for Use .	60-83

BittWare Drivers No Longer Recommended for Use	60-100
Diamond Drivers No Longer Recommended for Use	60-109
Displays and Logging Blocks No Longer Recommended for Use	60-138
GE Intelligent Platforms Drivers No Longer Recommended for Use	60-143
HUMUSOFT Drivers No Longer Recommended for Use	60-159
J1939 Drivers No Longer Recommended for Use . . .	60-167
Keithley Drivers No Longer Recommended for Use	60-179
MathWorks Drivers No Longer Recommended for Use	60-206
Measurement Computing Drivers No Longer Recommended for Use	60-211
National Instruments Drivers No Longer Recommended for Use	60-430
Real Time Devices Drivers No Longer Recommended for Use	60-461
Texas Instruments Drivers No Longer Recommended for Use	60-485
UDP Blocks No Longer Recommended for Use	60-492
Utility Blocks No Longer Recommended for Use . . .	60-497
XCP Drivers No Longer Recommended for Use	60-501

Introduction, RS-232

Simulink Real-Time I/O Library

- “I/O Driver Blocks” on page 1-2
- “Add I/O Blocks to Simulink Model” on page 1-11
- “Defining I/O Block Parameters” on page 1-13

I/O Driver Blocks

In this section...

- “Speedgoat I/O Modules” on page 1-2
- “Third-Party Driver Blocks” on page 1-2
- “I/O Driver Block Library” on page 1-3
- “Memory-Mapped Devices” on page 1-4
- “ISA Bus I/O Devices” on page 1-4
- “PCI Bus I/O Devices” on page 1-4
- “Simulink Real-Time I/O Driver Structures” on page 1-5
- “Simulink Real-Time Support and SimState” on page 1-7
- “PWM and FM Driver Block Notes” on page 1-9
- “Driver Block Documentation” on page 1-10

The Simulink Real-Time environment is a solution for prototyping and testing real-time systems using a desktop computer. In support of this, the software allows you to add I/O blocks to your model. The blocks of the Simulink Real-Time library provides a particular function of an I/O module. By using I/O blocks in your model, you can generate executable code tuned specifically to your I/O requirements.

You add I/O driver blocks to your Simulink model to connect your model to I/O modules (I/O boards). These I/O modules then connect to the sensors and actuators in the physical system.

Speedgoat I/O Modules

Speedgoat real-time target machines are available with a number of I/O modules. See “Speedgoat I/O Modules” on page 51-3.

Third-Party Driver Blocks

In addition to the blocks contained in the Simulink Real-Time library, you can also use third-party driver blocks in your Simulink Real-Time model. The description of these blocks is beyond the scope of the Simulink Real-Time documentation. See the provider of the third-party driver blocks for information on those boards and driver blocks.

I/O Driver Block Library

A driver block does not represent an entire board, but an I/O section supported by a board. Therefore, the Simulink Real-Time library can have more than one block for each physical board. I/O driver blocks are written as C-code S-functions (noninlined S-functions). The source code for the C-code S-functions is included with the Simulink Real-Time software.

Note, if your model contains I/O blocks, take I/O latency values into account for the model sample time. Use the Simulink Real-Time Interactive Guide tool to find latency values for the supported boards:

www.mathworks.com/products/simulink-real-time/supported/hardware-drivers.html.

The Simulink Real-Time system supports PCI and ISA buses. If the bus type is not indicated in the driver block number, you can determine the bus type of a driver block by checking the block's parameter dialog box. The last parameter is either a PCI slot, for PCI boards, or a base address, for ISA boards.

You can open the I/O device driver library with the MATLAB® command `slrtlib`. The library `slrtlib` contains sublibraries grouped by the type of I/O function they provide.

This library also contains the following blocks:

- Simulink Real-Time Driver Examples — When you double-click this block, the **Demos** tab in the MATLAB Help Navigator opens, displaying the Simulink Real-Time examples and example groups.
- Help for Simulink Real-Time — When you double-click this block, the Simulink Real-Time roadmap page is displayed. You can access the Simulink Real-Time documentation with this block.

Note: The Simulink Real-Time documentation describes only the Simulink Real-Time blocks. It does not describe the actual board. Refer to the board manufacturer documentation for information about the boards.

When you double-click one of I/O block groups, the sublibrary opens, displaying a list grouped by manufacturer. Double-clicking one of the manufacturer groups then displays the set of I/O device driver blocks for the specified I/O functionality (for example, A/D, D/A, Digital Inputs, Digital Outputs, and so on).

When you double-click one of the blocks, a Block Parameters dialog box opens, allowing you to enter system-specific parameters. Parameters typically include

- Sample time
- Number of channels
- Voltage range
- PCI slot (PCI boards)
- Base address (ISA/104 boards)

Memory-Mapped Devices

The Simulink Real-Time software reserves a 112 KB memory space for memory-mapped devices in the address range

C0000 - DBFFF

Drivers for some memory-mapped devices, such as the `Softing CAN-AC2-104` board, support an address range higher than that supported by the Simulink Real-Time software. You must select an address range supported by both the device driver and the Simulink Real-Time software.

ISA Bus I/O Devices

There are two types of ISA boards:

- Jumper addressable ISA cards
- PnP (Plug and Play) ISA cards

The Simulink Real-Time software only supports jumper addressable ISA cards (non-PnP ISA boards) where you have to set the base address manually.

PCI Bus I/O Devices

The Simulink Real-Time I/O library supports I/O boards with a PCI bus. During the boot process, the BIOS creates a conflict-free configuration of base addresses and interrupt lines for the PCI devices in the target system. The user does not need to define base address information in the dialog boxes of the drivers.

PCI device driver blocks have an additional entry in their dialog boxes. This entry is called **PCI Slot (-1 Autodetect)** and allows you to use several identical PCI boards within one target system. This entry uses a default value of -1, which allows the driver to search the entire PCI bus to find the board. If you specify a single number, X, greater than 0, the driver uses the board in bus 0, slot X. When more than one board of the same type is found, you must use a designated slot number and avoid the use of autodetection. For manually setting the slot number you use a number greater than or equal to 0. If the board is not able to locate this slot in the target computer, your real-time application will generate an error message after downloading.

If this additional entry is set to a value equal to or greater than 0, you must be aware of the manufacturer's identification number (Vendor ID) and the board identification number (Device ID) of those boards supported by the I/O library. When the target is booted, the BIOS is executed and the target computer monitor shows parameters for the PCI boards installed on the target computer. An example is shown below:

Bus No.	Device No.	Func. No.	Vendor ID	Device ID	Device Class	IRQ
0	4	1	8086	7111	IDE controller	14/15
0	4	2	8086	7112	Serial bus controller	10
0	11	0	1307	000B	Unknown PCI device	N/A
1	0	0	12D2	0018	Display controller	11

In this example, the third line indicates the location of the Measurement Computing™ PCI-DIO48 board. This is known since the Measurement Computing vendor ID is 0x1307 and the device ID is 0xb. In this case, you can see that the Measurement Computing board is plugged into PCI slot 11 (Device No.), and that this value must be entered in the dialog box entry in your I/O device driver for each model that uses this I/O device.

Simulink Real-Time I/O Driver Structures

Properties for Simulink Real-Time I/O drivers are usually defined using the parameter dialog box associated with each Simulink block. However, for more advanced drivers, the available fields defined by text boxes, check boxes, and pull-down lists are inadequate

to define the behavior of the driver. In such cases, you must provide a more textual description to indicate what the driver has to do at runtime. *Textual* in this context refers to a programming-language-like syntax and style.

The Simulink Real-Time software currently uses a string description contained in message structures for the conventional RS-232, GPIB, CAN (initialization), and the general counter drivers (AMD9513).

What is a message structure? — A message structure is a MATLAB array with each cell containing one complete message (command). A message consists of one or more statements.

First Message	Second Message	Third Message
Message(1).field	Message(2).field	Message(3).field
Message(1).field	Message(2).field	Message(3).field
Message(1).field	Message(2).field	Message(3).field

Syntax of a message statement — Each statement in a message has the following format:

```
Structure_name(index).field_name = <field string or value>
```

The field names are defined by the driver, and need to be entered with upper- and lowercase letters as defined. However, you can choose your own structure name and enter that name into the driver parameter dialog box.

Creating a message structure — You could enter the message structure directly in the edit field of the driver parameter dialog box. But because the message structure is an array and very large, this becomes cumbersome very easily.

A better way is to define the message structure as a variable in the MATLAB workspace and pass the variable name to the driver. For example, to initialize an external A/D module and acquire a value during each sample interval, create a script file with the following statements:

```
Message(1).senddata='InitADConv, Channel %d'  
Message(1).inputports=[1]  
Message(1).recdata=' '  
Message(1).outputports=[]  
  
Message(2).senddata='Wait and Read converted Value'
```

```
Message(2).inputports=[]
Message(2).recdata='%f'
Message(2).outputports=[1]
```

This approach is different from other Simulink Real-Time driver blocks:

- The script containing the definition of the message structure has to be executed before the model is opened.

After creating your Simulink model and message script, set the preload function of the Simulink model to load the script file the next time you open the model. In the Command Window, type

```
set_param(gcs, 'PreLoadFcn', 'script_name')
```

- When you move or copy the model file to a new folder, you also need to move or copy the script defining the message structure.

During each sample interval, the driver block locates the structure defined in the Block Parameters dialog box, interprets the series of messages, and executes the command defined by each message.

Specific drivers and structures — For detailed information on the fields in a message structure, see the following topics:

- “RS-232/422/485 Simulink Block Reference” on page 2-11
- “Initialization and Termination CAN Messages” on page 4-11

Simulink Real-Time Support and SimState

You can save complete model simulation states while simulating, on a development computer, a Simulink model that contains some Simulink Real-Time blocks. The software does not support this behavior when executing such a model on the target computer.

For this operation, set the **Save complete SimState in final state** check box in the **Data Import/Export** pane of the Configuration Parameters dialog box. If your model contains the following blocks, you cannot save complete model simulation states while simulating on the development computer.

- ASCII Encode
- ASCII Decode

- Async Buffer Read
- Async Buffer Write
- Baseboard Serial
- Baseboard Serial F
- Bit Packing (Utilities library)
- Bit Unpacking (Utilities library)
- Byte Packing (Utilities library)
- Byte Unpacking (Utilities library)
- Commtech Fastcom[®] 422/2-PCI
- Commtech Fastcom 422/2-PCI F
- Commtech Fastcom 422/2-PCI-335
- Commtech Fastcom 422/2-PCI-335 F
- Commtech Fastcom 422/4-PCI-335
- Commtech Fastcom 422/4-PCI-335 F
- Condor[®] 1553 BC List
- Create Ethernet Packet (Ethernet library)
- Diamond Systems Emerald-MM Serial
- Diamond Systems Emerald-MM Serial F
- Diamond Systems Emerald-MM8 Serial
- Diamond Systems Emerald-MM8 Serial F
- FIFO bin read
- FIFO ASCII read
- FIFO write
- Qatech[®] DSCP-200/300
- Qatech DSCP-200/300 F
- Qatech ESC-100
- Qatech ESC-100 F
- Qatech QSC-100
- Qatech QSC-100 F
- Qatech QSC-200/300

- Quatech QSC-200/300 F
- UDP Receive
- UDP Send

To prevent these messages, clear the **Save complete SimState in final state** check box in the **Data Import/Export** node of the Configuration Parameters dialog box.

PWM and FM Driver Block Notes

In PWM and FM driver blocks, your control over the output frequency and duty cycle is not precise. In particular, these values are affected by the way that the base frequency is selected, as described in this section. The base frequency value is exact.

At the beginning of each sample time, two unsigned 16-bit integers, n and m , are computed based on the block parameters and the current values of the input signals. During the current sample period, the output signal is held high for m cycles of the base frequency, low for the next $n-m$ cycles, high for the next m cycles, and so forth.

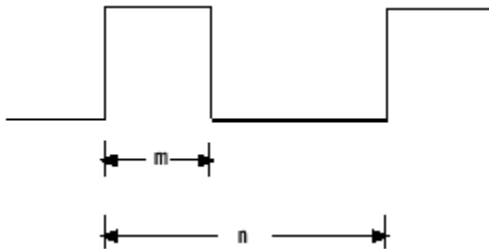

For a base frequency b , this results in a rectangular output signal of frequency b/n and duty cycle m/n . Because m and n must be integers, it is not possible to provide a continuous range of output frequencies and duty cycles with perfect exactness.

For example, assume that you want to configure an FM block with a duty cycle (m/n) of $1/2$. The input signal f to this block is a relative frequency. It specifies an output frequency of $b \times f$. Because m and n must be integers, it is not always possible to find values of m and n such that f will equal b/n exactly and n will equal $2 \times m$ (duty cycle $m/n = 1/2$) exactly. Such an exact match is only possible when the input signal f equals $1/4$, $1/6$, $1/8$, and so forth. The output frequencies for the intervening input signal f values are approximate. The errors are smaller as f approaches 0 and larger as f approaches 1.

Hint, to achieve the smallest margin of error, select the largest possible base frequency. The fact that n and m must be 16-bit integers imposes a lower limit of

$$b / (2^{16} - 1)$$

on the frequencies that can be generated using a given base frequency.

Driver Block Documentation

The typical Simulink Real-Time block documentation briefly describes the supported board, then describes the parameters for each of the blocks that support the board. Included in the documentation for each board is a board characteristics table. Board characteristics tables can include the following information:

Characteristic	Specifies...
Board name	Name of the board supported by the blocks. For example, National Instruments® PCI-6221.
Manufacturer	Manufacturer of the board. For example, National Instruments.
Bus type	Bus that is used by the board. For example, PCI or ISA.
Access method	Whether the board is memory mapped or I/O mapped.
Multiple block instance support	If you can use multiple blocks for the same function on the same board. For example, different blocks for different channels of an A/D device.
Multiple board support	If you can use multiple boards of the same type in one real-time application.

Add I/O Blocks to Simulink Model

Starting with a Simulink model, you can transform it to a Simulink Real-Time model that accesses I/O drivers using the Simulink Real-Time block library. The highest hierarchical level in the library is grouped by I/O function. The second level is grouped by board manufacturer. The manufacturer groups contain the driver blocks for specific boards.

This example uses the Simulink model `ex_slrt_osc` as an example of how to replace Simulink blocks with Simulink Real-Time I/O blocks.

- 1 In the Command Window, type

```
slrtlib
```

The **Library: slrtlib** window opens.

Alternatively, you can access the I/O driver library with the Simulink Library Browser.

- 2 Open a function group. For example, to open the A/D group, double-click the A/D block.

The manufacturer level opens. Within each manufacturer group are the blocks for a single function.

- 3 Open a manufacturer group. For example, to open the A/D driver blocks from Measurement Computing, double-click the group marked Measurement Computing.

The window with the A/D driver blocks for Measurement Computing opens.

- 4 In the Simulink Editor, type

```
ex_slrt_osc
```

The Simulink block diagram opens for the model `ex_slrt_osc`.

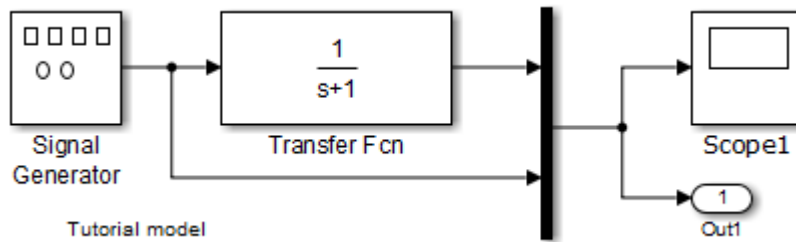

- 5 From the block library, click and drag the name of an Analog Input block to the Simulink block diagram. Likewise, click and drag the name of an Analog Output block to your model.

The Simulink software adds the new I/O blocks to your model.

- 6 Remove the Signal Generator block and add the Analog Input block in its place. Remove the Scope block and add the Analog Output block in its place.
- 7 Save the model with a new name, such as ex_slrt_iob_osc. The example model looks like this:

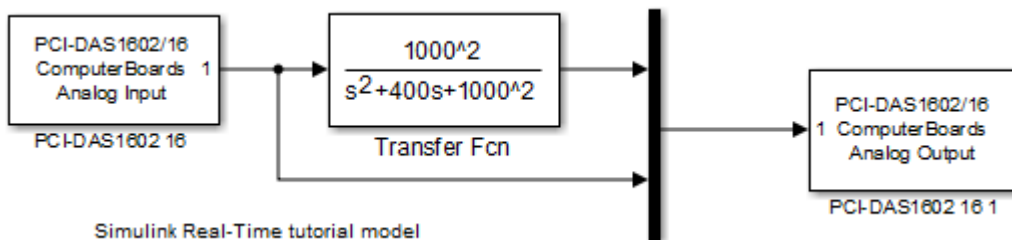

You cannot run this model unless the required I/O board is installed in your target computer. However, you can substitute driver blocks for another I/O board that is installed in the target computer.

Your next task is to define the I/O block parameters. See “Defining I/O Block Parameters” on page 1-13.

Defining I/O Block Parameters

The I/O block parameters define values for your physical I/O boards. For example, I/O block parameters include channel numbers for multichannel boards, input and output voltage ranges, and sample time.

This procedure uses the Simulink model `ex_slrt_osc` as an example, and assumes you have added an analog input and an analog output block to your model. To add an I/O block, see “Add I/O Blocks to Simulink Model” on page 1-11.

- 1 In the Simulink Editor, double-click the input block labeled **Analog Input**.

The dialog box for the A/D converter opens.

- 2 Fill in the dialog box. For example, for a single channel enter 1 in the **Number of Channels** box, select ± 10 V for the input range, and select **Single-ended (16 channels)** for the MUX switch position. Enter the same sample time you entered for the fixed step size in the **Solver** pane of the **Simulation > Model Configuration Parameters** dialog box. Enter the PCI slot for this PCI-bus board.

The Block Parameters dialog box looks like this:

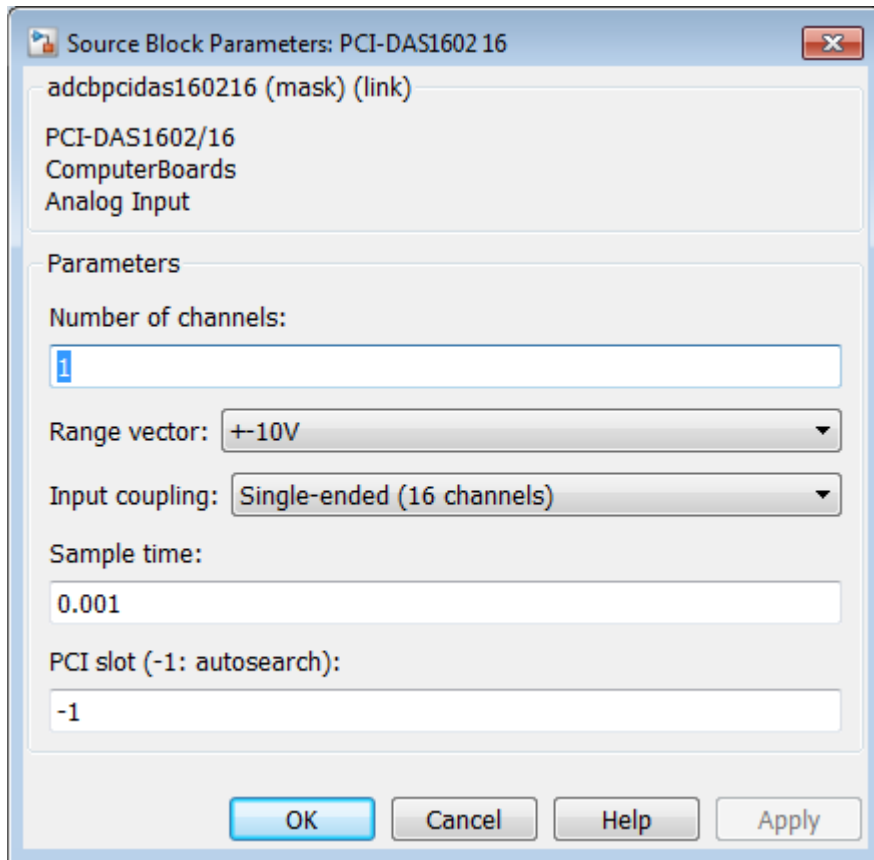

- 3 In the Simulink Editor, double-click the output block labeled Analog Output.

The dialog box for the D/A converter opens.

- 4 Fill in the dialog box. For example, for one channel enter [1] in the **Channel Vector** box; for an output level of ± 10 V enter the code [-10] in the **Range Vector** box. Enter the same sample time you entered for the fixed step size in the **Solver** pane of the **Simulation > Model Configuration Parameters** dialog box. Enter the PCI slot for this PCI-bus board.

The Block Parameters dialog box looks like this:

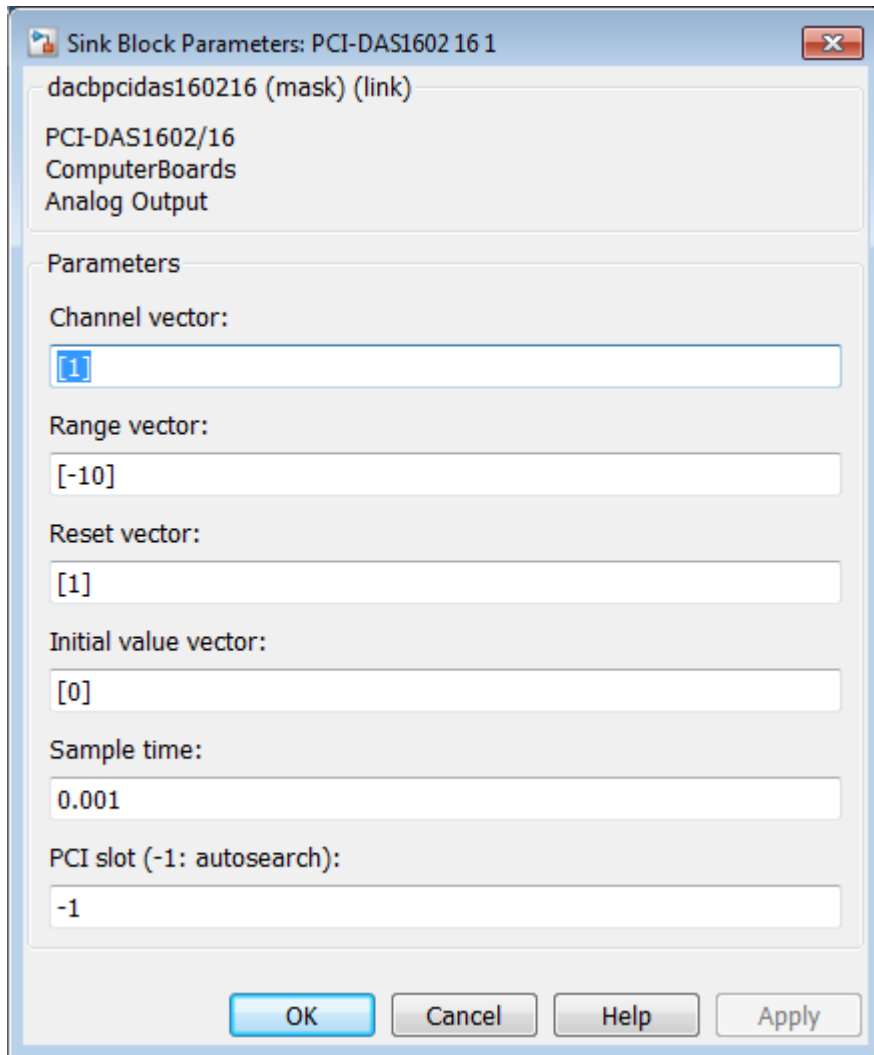

If you change the sample time by changing the target object property `SampleTime`, the sample times you entered in both of the I/O blocks are set to the new value. The step size you entered in the Configuration Parameters dialog box remains unchanged.

Serial Communications Support

- “RS-232 I/O Drivers” on page 2-2
- “RS-232/422/485 Drivers (Composite)” on page 2-5

RS-232 I/O Drivers

The Simulink Real-Time software interfaces the target computer to serial devices using either the COM1 or COM2 port of the main board, through Quatech drivers, through Diamond Systems drivers, or through Commtech drivers.

The Simulink Real-Time software supports RS-232 I/O communication with the following:

- Serial ports on the target computer
- Third-party Quatech PCI boards manufactured by B&B Electronics (www.bb-elec.com)
- Third-party Commtech PCI boards (www.commtech-fastcom.com)
- Third-party Diamond Systems PC/104 boards (www.diamondsystems.com)

For the target computer serial ports, the software can use these ports as the RS-232 I/O devices. You can initiate RS-232 communications with these ports and the accompanying Simulink Real-Time drivers.

The software also supports the following:

- RS-232 — QSC-100 and ESC-100 PCI boards from Quatech
- RS-422, RS-485 — QSC-200/300 PCI boards and DSCP-200/300 dual channel PXI[®] boards from Quatech, Fastcom: 422/2-PCI adapter, Fastcom: 422/2-PCI-335 from Commtech (www.commtech-fastcom.com)
- RS-232, RS-422, RS-485 — Emerald-MM and Emerald-MM-8 PC/104 boards from Diamond Systems. These boards provide 4 and 8 serial ports, respectively. These boards are jumper-configurable for the following models:
 - EMM-XT, which can support two ports each for RS-232 and RS-485.
 - EMM-4485-XT, which supports four ports for RS-422 and RS-485.
 - EMM-4M-XT, which supports four ports for RS-232, RS-422, and RS-485.

See the manufacturer documentation for details on how to configure your jumpers.

Note: When you configure the board for the RS-485 protocol, configure your model to manually control the RTS bit to turn the transmitter on and off. You must use a

convention, such as counting sample time steps, to decide when the model should turn off the transmitter after sending data.

The Simulink Real-Time block library provides a set of functionally similar drivers for these boards. See “RS-232/422/485 Simulink Block Reference” on page 2-11 for a description of the driver blocks that support the different protocols.

The Simulink Real-Time block library supplies composite drivers to support RS-232 I/O communication (see “RS-232/422/485 Drivers (Composite)” on page 2-5). The composite drivers support RS-232 I/O for the target computer serial ports, the Quatech RS-232, RS-422, and RS-485 I/O devices, and the Diamond Systems RS-232 I/O devices. These drivers support communication in asynchronous binary mode. The Simulink Real-Time block library uses Simulink blocks for the I/O drivers. The composite drivers provide a simple ASCII encode/decode for the send and receive RS-232, RS-422, and RS-485 blocks. This set of drivers has the descriptive name “composite” because the driver represents each functional piece of the driver as a Simulink block. For more precise behavior, you can customize the RS-232 driver with these blocks.

Internal Drivers

The composite drivers also include internal drivers. Use them only when you need to modify the composite subsystems for your use. The internal blocks are composite blocks for:

- Quatech ESC-100, QSC-100, QSC-200/300, DSCP-200/300 series
- Mainboard Baseboard series
- Diamond Systems Emerald-M and Emerald-MM8 series
- Fastcom 422/2-PCI, Fastcom 422/2-PCI-335, Fastcom 422/4-PCI-335 series

The internal blocks and subsystems of the RS-232/422/485 boards are controlled from the mask parameters dialog box for the send/receive subsystem in which they are used.

Serial Connections for RS-232

The Simulink Real-Time software supports serial communication with the COM1 and COM2 ports on the target computer.



Your real-time applications can use these RS-232 ports as I/O devices. With the typical DTE/DCE configuration of the RS-232 device, the target computer is connected to the device with a null modem cable.

RS-232/422/485 Drivers (Composite)

This topic describes the components that make up the RS-232 and RS-422/485 composite drivers, and how you can create a model using these drivers. These drivers perform RS-232 or RS-422/485 asynchronous communications.

The Simulink Real-Time software supports the target computer serial ports (main board), Quatech RS-232/422/485 devices, Diamond Systems RS-232 devices, and Commtech Fastcom: 422/2-PCI adapters with composite drivers. These drivers distribute the functionality of the device across several subsystems and blocks. For most RS-232/422/485 requirements, you can use these RS-232/422/485 drivers as they are implemented. However, if you need to customize the Simulink Real-Time RS-232/422/485 drivers, the composite nature of the target computer serial port, Quatech RS-232/422/485, Diamond Systems RS-232, and Commtech Fastcom drivers enables you to do so.

Note the following characteristics of the Commtech Fastcom: 422/2-PCI adapter boards (www.commtech-fastcom.com):

- The Fastcom 422/2-PCI board has two independent RS-422 channels.
- The Fastcom 422/2-PCI board can handle baud rates up to 1.5 megabits/second.
- The Fastcom 422/2-PCI board FIFO is fixed at 128 bytes for receive and transmit.

Note the following characteristics of the Commtech Fastcom: 422/2-PCI-335 and Fastcom: 422/4-PCI-335 adapter boards (www.commtech-fastcom.com):

- The Fastcom 422/2-PCI-335 board has two independent RS-422/485 channels, the Fastcom 422/4-PCI-335 board has four independent RS-422/485 channels.
- The Fastcom 422/2-PCI-335 and Fastcom 422/4-PCI-335 board can handle baud rates up to 6.25 megabits/second.

Note: Many of the blocks that support the RS-232 and RS-422/485 composite drivers are common across the main board, Quatech, and Diamond Systems boards. The descriptions for these blocks are applicable across drivers, with additional information for specific boards.

In this section...

“Adding RS-232 Blocks” on page 2-6

In this section...

“Building and Running the Real-Time Application (Composite)” on page 2-10

“RS-232/422/485 Simulink Block Reference” on page 2-11

Adding RS-232 Blocks

You add RS-232 subsystem blocks to your Simulink model when you want to use the serial ports on the target computer, Quatech QSC-100 or ESC-100, or Diamond Systems Emerald-MM or Emerald-MM-8 serial device connected to the target computer, for I/O.

After you create a Simulink model, you can add Simulink Real-Time driver blocks and configure those blocks. The following procedure describes how to use the serial ports on the target computer for I/O with the composite drivers.

Before you start, decide what COM port combinations you want to use. The example has you configure the Baseboard Send/Receive block. To configure this block, you need to select serial port pairs. This parameter specifies the ports for which you are defining transmit and receive. You have a choice of the following:

- Com1 / none
- Com2 / none
- Com1 / Com3
- Com2 / Com4
- none / Com3
- none / Com4
- Custom

If you choose either the Com1 / Com3 or Com2 / Com4 pair, check that the port pair shares an interrupt. If the port pair does not share an interrupt, you cannot use the two ports as a pair.

Alternatively, you can define a Custom port pair. A Custom port pair is one that does not match the existing combinations of port pairs. When you select Custom, the dialog allows you to configure your own port pair. For example, you can set the IRQ and two addresses for the port pair. If one of the ports is not used, set that address to 0.

Normally, the ports are set to the following:

COM1 — 0x3F8, IRQ 4

COM2 — 0x2F8, IRQ 3

COM3 — 0x3E8 (if present), IRQ 4

COM4 — 0x2E8 (if present), IRQ 3

A **Custom** port pair is one where one or both ports of the pair are set to addresses other than these conventions, or one for which you want to assign a different IRQ value. Some boards allow you to set the IRQ numbers independently.

If you choose the port pairs **Com1 / Com3** or **Com2 / Com4**, you need to include one Send/Receive subsystem block in the model. If you choose to use COM1 and COM2, or COM1 and a custom port pair, you need to include two Send/Receive blocks in the model.

The following example shows two models, one that uses a standard **Com1 / Com3** port pair, and one that uses custom port pairs:

- 1 In the Command Window, type

```
slrtlib
```

The Simulink Real-Time driver block library opens.

- 2 Double-click the RS-232 group block.

A window with blocks for RS-232 composite drivers opens.

Alternatively, you can access the Simulink Real-Time block library from the Simulink Library Browser. In the Simulink Editor, and from the **View** menu, click **Show Library Browser**. In the left pane, double-click **Simulink Real-Time**, and then click **RS232**.

- 3 Drag an ASCII Encode block to your Simulink model. This block encodes input for the RS-232 Send Receive block.
- 4 Configure this block.
- 5 Drag an ASCII Decode block to your Simulink model. This block decodes output from the RS-232 Send Receive block.
- 6 Configure this block.
- 7 Double-click the Mainboard group block.

- 8 Depending on your port pair configuration, drag one or two Baseboard RS-232 Send/Receive blocks to your Simulink model.
- 9 Double-click the Baseboard RS-232 Send/Receive block.
- 10 Configure this block. Note the following:
 - Pay particular attention to the **Parameter** group **Board Setup** entry.
 - When you select the **Receive Setup** entry, for each channel, set the value of the **Receive Sample Time** parameter to a sample time value faster than the data being sent. Do not leave this value at -1. You must set this parameter for all channels, including channels that you are not using; otherwise, you will receive an error when generating code for the real-time application.
- 11 Add a Pulse Generator and Target Scope block.
- 12 Configure the Pulse Generator block so that its **Pulse type** is **Sample based**.

The dialog changes to display a **Sample time** parameter. Enter a **Sample time** that is slower than the one you set for **Receive Setup**.

- 13 From the Simulink Library Browser, select **Sinks**. Depending on your configuration, drag one or more Terminator blocks to your model. Connect this block to the unused RCV1 port to suppress unused port messages.

From the Simulink Library Browser, select **Sources**. Depending on your configuration, drag the Ground block to your model. Connect this block to the unused XMT3 port to suppress unused port messages.

Your model might use one block or two.

The single-block model uses the Com1 /Com3 port pair:

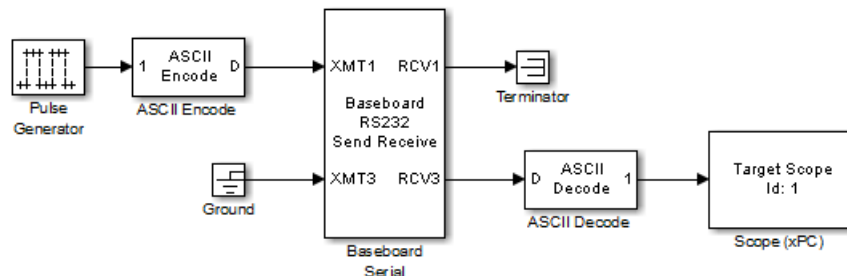

The two-block model uses two sets of Custom port pairs:

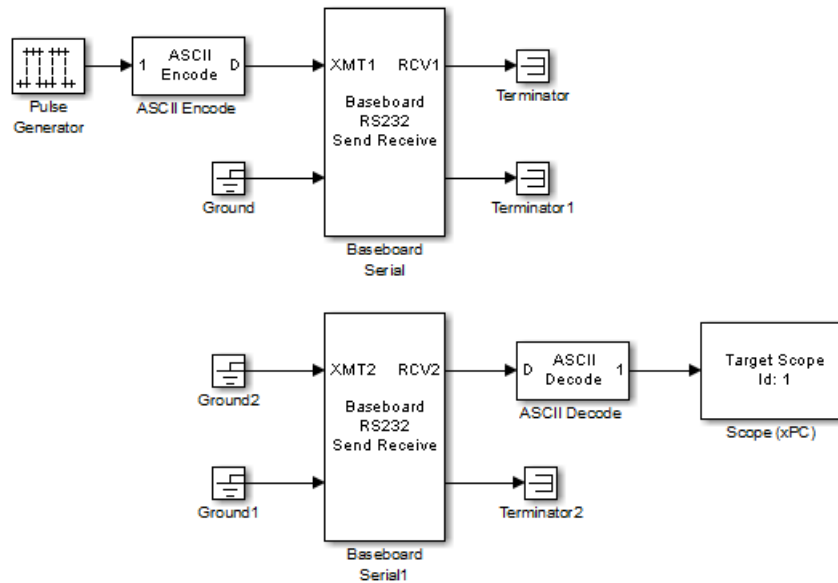

- 14 Double-click a Baseboard RS232 Send Receive block. Enter values to configure the port(s) on the target computer for this board.

Note: This is a dynamic dialog box that changes depending on the **Parameter group** selection.

For example, if the **Parameter group** is **Board Setup** and the target computer port is connected to COM1/COM3, your Send Receive block dialog box looks like this:

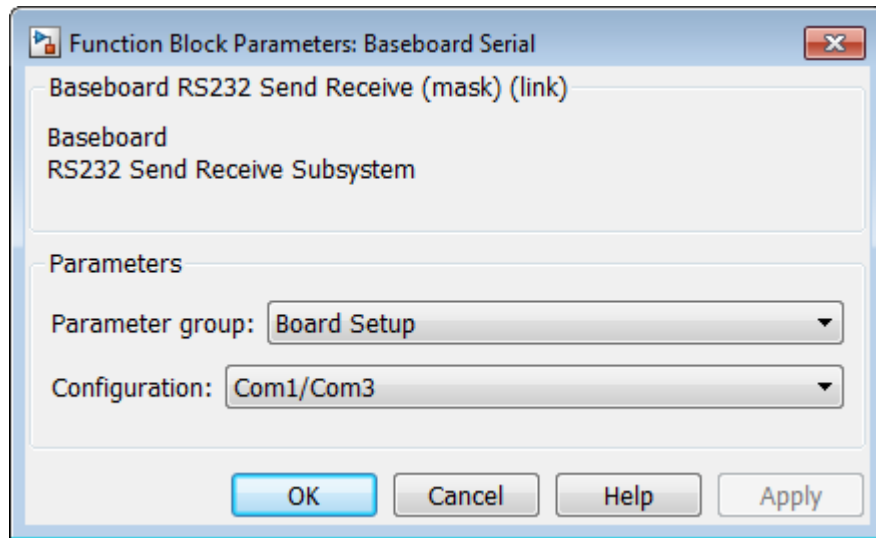

For more information on entering the block parameters, see RS-232/RS-422/RS-485 Send/Receive (Composite).

- 15 Click **OK**. The Send Receive block dialog box dialog box closes.

Your next task is to build and run the real-time application.

Building and Running the Real-Time Application (Composite)

The Simulink Real-Time software and Simulink Coder™ create C code from your Simulink model. You can then use a C compiler to create executable code that runs on the target computer. This topic assumes that you know how to configure your model to create a real-time application. See “Build and Download Real-Time Application”.

After you have added the RS-232 blocks for the main board to your Simulink model and configured your model, you can build your real-time application.

Note: In this example, you cannot use a serial port to link the development and target computers. You can only use COM1 if it is not already in use for a serial link. Additionally, if COM1 and COM3 share an interrupt, you cannot use COM3 if COM1 is already in use for a serial link.

- 1 In the Simulink Editor, and from the **Code** menu, click **C/C++ Code > Build Model**.
- 2 In the Command Window, type

```
start(tg)
```

RS-232/422/485 Simulink Block Reference

The Simulink Real-Time software supports RS-232/422/485 communication with driver blocks in your Simulink model.

This section includes the following topics:

- “Signal Data Types” on page 2-11 — Describes signal data types that composite drivers support.
- **ASCII Encode/Decode (Composite)** — (Generic) Describes encoder and decoder blocks. Encoders convert input signals for the send/receive subsystem to ASCII strings. ASCII decoders parse the string from the Send/Receive subsystem.
- **FIFO Read/Write (Composite)** — (Generic) Describes FIFO read and write blocks.
- **RS232 State (Composite)** — (Generic) Monitors the error state information that is present in the output vector from the blocks.
- **RS-232/RS-422/RS-485 Send/Receive (Composite)** — Provides blocks for sending and receiving.
- **Modem Control (Composite)** — Controls the state of either or both of the RTS and DTR output lines.
- **Modem Status (Composite)** — Reads the states of the four input modem control lines.

Signal Data Types

Signals between blocks in composite drivers can be one of several basic data types, 8-bit and 16- or 32-bit. These types are structures.

8-bit data types are NULL-terminated strings that are represented as Simulink vectors. The width is the maximum number of characters that can be stored. In the following figure, M is the actual set of stored characters and N is the maximum number of

characters that can be stored. This figure illustrates 8-bit int NULL-terminated and 8-bit uint NULL-terminated data types.

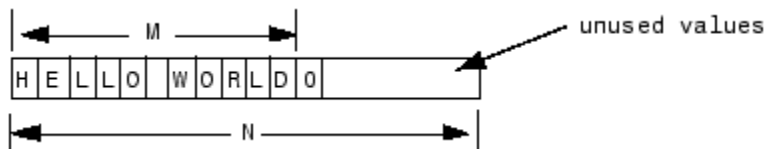

This string has 11 characters terminated with a NULL byte (0). This data type cannot contain a NULL byte as part of the real data.

16- and 32-bit data types use the first element of the vector as a count of the valid data. In the following figure of a 16-bit data type, C is the count of the valid data, N is the width of the vector. This figure illustrates count + 16-bit int and count + 16-bit uint data types. It also applies to count + 32-bit int and count + 32-bit uint data types

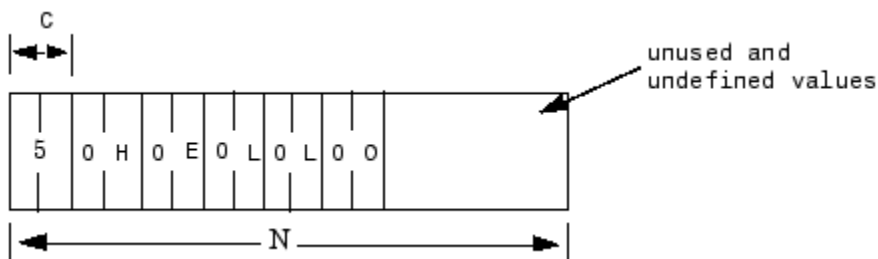

These serial blocks interpret each entry in the vector as a single character. The low-level Send block writes the low-order byte of each entry to the UART. The 16- and 32-bit data types allow the embedding of 8-bit data values, including 0. The 8-bit data type is most useful with the ASCII Encode and Decode blocks. The 16- and 32-bit data types are most useful for binary data streams.

Handling Zero Length Messages

As a general rule, configure a FIFO read block of your model serial I/O to execute faster than the model receives data. Doing so prevents the receive FIFO buffer from overflowing. This implies that you must configure your model to deal with the possibility that a FIFO read block may not have a message on its output.

Receive FIFOs might not have enough characters to satisfy a FIFO read operation. A model that receives serial I/O might have a FIFO read block that will execute in this

situation. This will cause a FIFO read block to perform one of the following, depending on how you configure the behavior:

- Return the last message it received
- Return a zero length message

The Simulink Real-Time library of composite serial drivers has three FIFO read blocks, FIFO Read HDRs, FIFO Read Binary, and FIFO Read (described in FIFO Read/Write). For the FIFO Read HDRs or FIFO Read Binary blocks, you configure this behavior with the **Output behavior** parameter. The FIFO Read block returns either a new message or a zero length message.

If you need to execute model code only if a new message arrives, check the first element of the returned vector, depending on the string data type, as described in the following. If the message has nonzero length, enable a subsystem to process the new string; otherwise, do not process it.

- In the 8-bit data type, the returned string is NULL-terminated. Therefore, if the first element is 0, the string has zero length and the FIFO read did not detect a new message.
- In the 16- and 32-bit data types, the first element is the number of characters in the string. This value is 0 if the FIFO read did not detect a new message.

Controlling When You Send a Message

You can use the structure of both serial data types (“Signal Data Types” on page 2-11) to control when a message is sent. In both cases, a 0 in the first position indicates an empty string.

- 8-bit data types — A value of 0 value in the first position is the NULL terminator for the string.
- 16- and 32-bit data types — The first position is the number of characters that follow.

If you connect an empty string to the XMT port on one of the send/receive subsystems, no characters are pushed onto the transmit FIFO. You can get this empty string using one of the following:

- If you have a single string that you want to send occasionally, use the **Product** block to multiply the entire string by either 0 or 1. In this case, the 0 or 1 value becomes a transmit enable. To optionally optimize this operation, you can use a **Demux** block to

extract the first element and multiply just that element by 0 or 1, then use the MUX block to combine it again.

- Use a **Manual Switch**, **Multiport Switch**, or **Switch** block (configured for two ports to choose between different messages, with one of the choices being a vector of 0 values). The **Switch** block only selects between vectors of the same width. However, because the string length does not need to use the whole vector, you just need to fill them to the same width with 0 values following your data.

Defining the Commtech Fastcom Baud Rate for Commtech Fastcom 422/2-PCI Boards

The Commtech Fastcom 422/2-PCI board can handle baud rates up to 1.5 megabaud. To configure a baud rate for the board, you need to set the following parameters. Note, this section applies to only Commtech Fastcom 422/2-PCI boards, not Commtech 422/2-PCI-335 and 422/4-PCI-335 boards.

- **Clock Bits** in the Fastcom 422/2-PCI Send Receive block with the **Parameter group** parameter set to **Board Setup**
- **Baud Divisor** in the Fastcom 422/2-PCI Send Receive block with the **Parameter group** parameter set to **Basic Setup**

The Fastcom 422/2-PCI board has two serial channels, each of which has an independent counter (baud clock). A master clock generator, which has a phase locked loop, controls the master clock for both serial channels. The master clock generates a maximum baud rate for both channels. The block determines the actual baud rate of a channel by dividing the maximum baud rate from the master clock by the baud rate divisor (n).

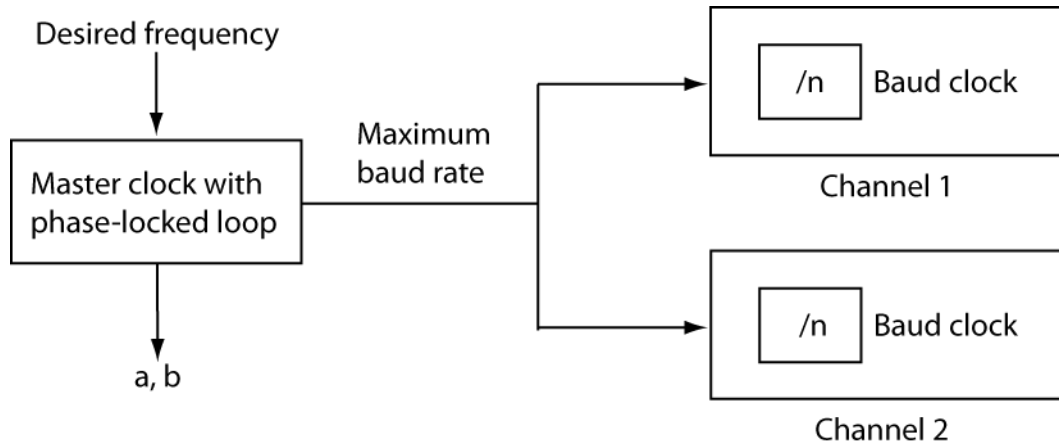

To set the block parameters for this board, choose a maximum baud rate, as follows. This procedure assumes that both channels require different baud rates. Determine a common base clock that can be divided to produce the required baud rates for both channels, as follows:

- 1 In the Command Window, type a command like the following. With a desired frequency (for example, **1.5e6**) as the desired input, the `fc422mexcalcbits` utility calculates parameter values that you can use to configure the board rate for your board.

```
[a b df ] = fc422mexcalcbits(1.5e6)
```

This command returns three values.

```
a = 12199144  
b = 24  
df = 1500000
```

- 2 Examine the `df` value. The `df` value is the actual frequency the board will be able to attain compared to your desired frequency. If the actual attainable frequency does not meet your requirements, you might want to try another frequency. In this example, the board can match the desired frequency of 1500000 (1.5e6).
- 3 Enter the first two values in the **Clock Bits** parameter of the Fastcom 422/2-PCI Send Receive block with the **Parameter group** parameter set to **Board Setup**.

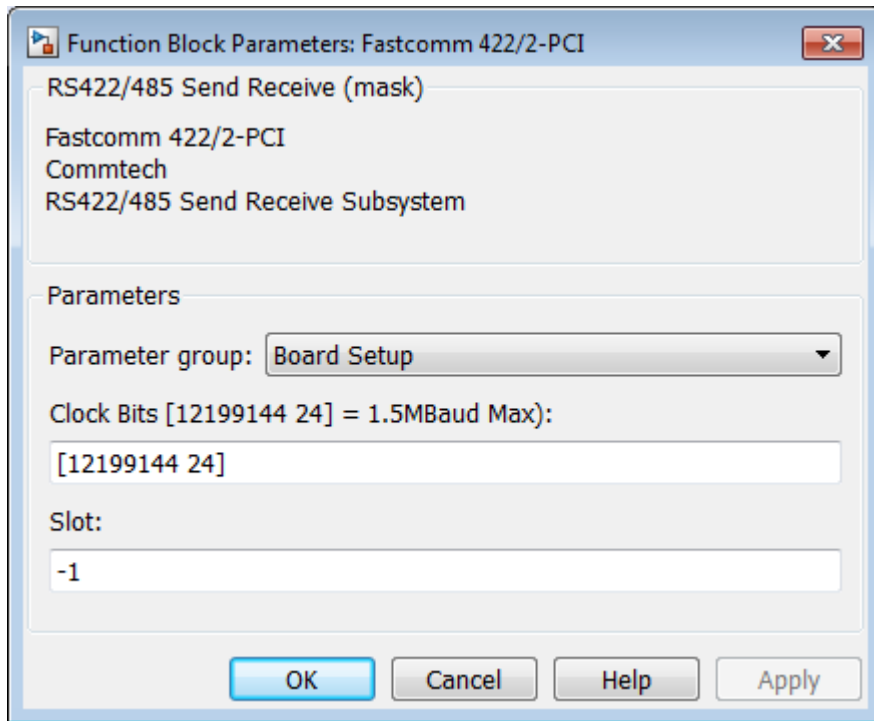

After you define a maximum baud rate, you can set a unique baud rate for each channel by choosing a different baud rate divisor for each channel. For example, you can have Channel 1 have a baud rate of 750000 (1500000/2) and Channel 2 have a baud rate of 1500000 (1500000/1). To set Channel 1 to have a baud rate of 750000, with the Fastcom 422/2-PCI Send Receive block with the **Parameter group** parameter set to **Basic Setup**, set

- **Port to modify** to 1
- **Baud Divisor** to 2

Note: For very slow baud rates (less than 30000), you must use the **Baud Divisor** parameter to achieve the desired baud rate.

See Also

fc422mexcalcbits

Serial Communications Support: Blocks

ASCII Encode/Decode (Composite)

ASCII Encode/Decode

Library

Simulink Real-Time Library for RS-232

Description

The ASCII Encode block generates a UINT8 output vector that contains a NULL-terminated string based on a `printf` like format string and data on the input ports.

The ASCII Decode block parses an input vector according to a format specifier similar to `scanf`, and makes converted values available to a Simulink program. The input vector to the ASCII Decode block can be either 8-bit or 16-bit and signed or unsigned. If the data format is 16-bit, the ASCII Decode block ignores the upper eight bits of each entry.

Encode Block Parameters

Format string

Enter a `printf` like format string. Each format specifier such as `%d` is replaced by the converted value that is present on the corresponding input variable. Acceptable format specifiers are `%c`, `%d`, `%i`, `%O`, `%u`, `%x`, `%e`, `%f`, and `%g`. These follow the normal description for `printf`.

Number of variables

Enter the number of input ports to this block. The value on each port is inserted into the output string with the format specified in **Format string**.

Max output string length

Enter the maximum allowed length of the converted string, in bytes. The block allocates enough memory to support this length for the output port. When selecting this length, take into account the NULL termination on the string.

If the converted string exceeds this length, the block returns an error and does not write that string to the output port.

Variable types

Enter one of the following: `{ 'double' }`, `{ 'int8' }`, `{ 'uint8' }`, `{ 'int16' }`, `{ 'uint16' }`, `{ 'int32' }`, and `{ 'uint32' }`. The default is `{ 'double' }`. This parameter specifies the Simulink data types allowed for the input ports. A cell vector with the same number of elements as specified in **Number of variables** can specify a different data type for each input port. A single element is replicated. For example,

```
nvars=3
```

`{ }` — The three inputs are doubles.

`{ 'uint8' }` — The three inputs are `uint8`.

`{ 'uint16', 'double', 'uint8' }` — The first input is a `uint16`, the second input is a `double`, and the third input is a `uint8`.

Decode Block Parameters

Format string

Enter a `scanf` like format string. Each format specifier such as `%d` needs to match a corresponding part of the input vector. Literal strings in the format need to match the first character plus the number of characters. Acceptable format specifiers are `%c`, `%d`, `%i`, `%o`, `%u`, `%x`, `%e`, `%f`, and `%g`. These follow the normal description for `scanf`.

Number of variables

Enter the number of output ports for this block. For example,

If **Format string** has the value of `%xmore text%x` and the input vector for the block has `cdmabcde fgh90`, you must specify the value of the **Number of variables** parameter as 2.

The first variable is assigned the value `0xcd`. Next, the string `mabcde fgh` is considered a match to `more text` because

- The first character for both strings is `m`.
- Both strings have the same number of characters.

The second variable is then assigned the value `0x90`. Note that the string `mabcde fgh` does not have to match exactly the value of **Format string**. This behavior is different from that for `scanf`, which requires an exact match.

Variable types

Enter one of the following: `{ 'double' }`, `{ 'int8' }`, `{ 'uint8' }`, `{ 'int16' }`, `{ 'uint16' }`, `{ 'int32' }`, and `{ 'uint32' }`. The default is `{ 'double' }`. This parameter specifies the Simulink data types allowed for the output ports. A cell vector with the same number of elements as specified in **Number of variables** can specify a different data type for each output port. A single element is replicated. For example,

`nvars=3`

`{ }` — The three outputs are doubles.

`{ 'uint8' }` — The three outputs are `uint8`.

`{ 'uint16', 'double', 'uint8' }` — The first output is a `uint16`, the second output is a `double`, and the third output is a `uint8`.

More About

- “RS-232 I/O Drivers” on page 2-2
- “RS-232/422/485 Drivers (Composite)” on page 2-5

External Websites

- www.bb-elec.com
- www.commtech-fastcom.com
- www.diamondsystems.com

ASCII Decode V2

ASCII Decode V2

Library

Simulink Real-Time Library for RS-232

Description

The `ASCII Decode` block parses an input vector produced by one of the following:

- Serial port `Receive` block
- Serial port `FIFO Read` block
- `ASCII Encode` block

It makes the converted values available to a Simulink program. It assumes that the input vector was prepared using an output format specifier similar to `printf` and uses an input format specifier similar to `scanf`.

The input vector to the `ASCII Decode` block can be either 8-bit or 16-bit and signed or unsigned. If the data format is 16-bit, the `ASCII Decode` block ignores the upper eight bits of each entry.

Note: This block generates inline code for the target computer. You cannot use it for Simulink simulation.

Block Parameters

Format

Enter a `scanf` like format string. Each format specifier such as `%d` must match a corresponding part of the input vector. Literal strings in the format must match the first character plus the number of characters. Acceptable format specifiers are the following, enclosed in single quotes. Failure to include these quotes causes simulation

failures: %c, %d, %i, %o, %u, %x, %e, %f, and %g. These follow the normal description for `scanf`. The number of format specifiers actually satisfied by the input string is known as the count output.

An example format string is:

```
'foo %d bar %f\n'
```

In this example, assume that the data from the FIFO read is 'foo 5'. In this case, the count output is 1 and the second output will be unchanged from the last time both were found in a string. If the block expects two values, and the returned count output value is less than two, there is an error in the data.

More About

- “RS-232 I/O Drivers” on page 2-2
- “RS-232/422/485 Drivers (Composite)” on page 2-5

External Websites

- www.bb-elec.com
- www.commtech-fastcom.com
- www.diamondsystems.com

FIFO Read/Write (Composite)

FIFO Read/Write

Library

Simulink Real-Time Library for RS-232

Description

This section describes the FIFO Read and Write blocks. Of particular note are the FIFO Read blocks, of which there are three. Use the following guidelines when using these blocks:

- Simple data streams — Use the FIFO Read block to read simple data streams. An example of a simple data stream is one that has numbers, separated by spaces, and that is terminated by a new-line character. The FIFO Read block is a simple block that can easily extract these numbers.
- More complicated data streams — Use the FIFO Read HDRS and FIFO Binary blocks for more complicated data streams. A more complicated data stream can be one that contains headers, messages of varying lengths, or messages without specific terminators. A message header consists of one or more character identifiers at the beginning of a message that specify what data follows. ASCII messages normally have a variable length and a terminator. Typically, the messages of a particular device use the same predefined terminator. Binary messages are normally of fixed length without a specific terminator.

The FIFO Read HDRS or FIFO Binary blocks are also useful to work with devices that can send different messages at different times.

The three FIFO read block types need their input to be of type `serialfifo_ptr`, which is output from F type Send Receive subsystems.

The following are examples of when you can use the FIFO read block.

- For an instrument that sends a string like the form
`<number> <number> ... <CR><LF>`

use the simple FIFO Read block to read the message. Configure the FIFO Read block **Delimiter** parameter for a line feed (value of 10). You should then connect the output to an ASCII Decode block with a format that separates the numbers and feeds them to the output ports.

- For an instrument that can send one of a number of different messages, and each message begins with a different fixed string, use the FIFO Read HDRS block. For example, a digital multimeter connected through an RS-232 port, might send a voltage reading and an amp reading with messages of the following format:

```
volts <number> <CR><LF>
amps <number> <CR><LF>
```

Configure the FIFO Read HDRs block **Header** parameter for the `volts` and `amps` headers, in a cell array: `{ 'volts', 'amps' }`. Also configure the **Terminating string** parameter for carriage return (13) and line feed (10): `[13 10]`.

You should then connect the output to multiple ASCII Decode blocks, one for each header and message. See the `xpcserialasciitest` and `xpcserialasciisplit` models in `xpcdemos` for examples of how to use this block in a model.

- For an instrument that sends a binary message, you typically know the length of each full message, including the header. Configure the FIFO Read Binary block **Header** parameter for the headers of the message, in a cell array, and the **Message Lengths** parameter for the message lengths. See the `xpcserialbinarytest` and `xpcserialbinarysplit` models in `xpcdemos` for further examples of how to use this block in a model.

The FIFO Read block is the read side of a FIFO read/write pair. The block functions in two modes, set using the **Read to delimiter** check box.

- If you select the **Read to delimiter** check box, the block only reads elements if the specified delimiter has been written to the write side of the FIFO (the FIFO Write block). If the delimiter is found, the block returns elements up to and including the delimiter in the output vector. If the delimiter is not found, the block returns a zero length vector, as determined by the data type. (If you have a zero length vector, you might want to have your model perform a particular operation, or ignore the case.)
- If you clear the **Read to delimiter** check box, the block returns a number of elements between **Minimum read size** and the smaller of the number of elements currently in the FIFO and **Maximum read size**.

Tip You usually select the **Read to delimiter** check box when performing ASCII reads and clear it when performing binary reads.

FIFO Read Block Parameters

Maximum read size

Specify the maximum number of characters that you will ever expect to be returned by this block. The resulting vector size will be one more than this maximum number of characters. This block indicates the number of characters being returned using the extra element as:

- A null terminator for the 8-bit data types
- The character count for the 16- and 32-bit data types

Be sure to enter a large enough number. If this number is too small, the block might not be able to return anything. For example, if you enter a value 10, but on execution the FIFO contains 11 characters plus the null terminator, the block will not return any characters. On the other hand, if it contains 5, the block returns 5 characters plus the null terminator.

If you select the parameter **Max and Min read size ports**, the block interprets the value input on this port to be the maximum number of characters to return. The actual maximum number of characters to return is the smaller of the value on the max input port or the maximum read size in the block parameters. This is mainly useful in binary mode when the **Read to delimiter** check box is not selected.

Minimum read size

Enter the smallest desired read size in bytes. The FIFO must contain at least this number of elements before elements will be returned. If you select the **Max and Min read size ports** check box, this value is superseded by the external signals.

Read to delimiter

Select this check box to enable the return of element sets that terminate with the **Delimiter** value. Use this parameter when working with character-based elements.

Delimiter

Enter the decimal value for an 8-bit input terminator. This parameter specifies the value on which a FIFO read operation should terminate. It works with the **Read to delimiter** parameter. By default, this block looks for a carriage return. It only

returns characters when one is found. For reference, the decimal value of a carriage return is 13, a line feed is 10.

Output vector type

From the list, select `count+32 bit int`, `count+32 bit uint`, `count+16 bit int`, `count+16 bit uint`, `8 bit int null terminated`, or `8 bit uint null terminated`. This parameter specifies the output vector type. The 8-bit data types produce a null terminated string in the output vector. For 16- and 32-bit data types, the first element contains the number of elements to expect in the rest of the output vector.

Max and Min read size ports

Select this check box to enable the maximum and minimum input ports. When this check box is selected:

- The value from the maximum input port is the maximum number of characters to be removed from the FIFO. If this number exceeds the value of **Maximum read size**, the block disregards the value from the maximum input port and takes the value of **Maximum read size** as the maximum number of characters to be removed from the FIFO.
- The value from the minimum input is the minimum number of characters the FIFO must contain before elements can be returned. This value supersedes the value set with the **Minimum read size** parameter.

Enable passthrough

Select this check box to pass the maximum read input through to the passthrough output.

SampleTime

Base sample time or a multiple of the base sample time.

FIFO Write Block Parameters

Size

Enter the number of elements that can be held in the FIFO at one time. If a write operation to the FIFO causes the number of elements to exceed **Size**, an error occurs.

Input vector type

This parameter specifies the input vector type. From the list, select one of:

- **count+32 bit int, count+32 bit uint, count+16 bit int, count+16 bit uint** — For the 16- and 32-bit data types, include as first element the number of elements to expect in the rest of the input vector. The count controls how many bytes that the block copies into the FIFO. The block does not copy the count itself into the FIFO.
- **8 bit int null terminated, 8 bit uint null terminated** — For the 8-bit data types, provide a null terminated string in the output vector. The block copies data into the FIFO up to, but not including, the null terminator.

For more information, see “RS-232/422/485 Drivers (Composite)” on page 2-5.

Data present output

Select this check box to create a Boolean output that is true if data is present in the FIFO. The transmit side of the send/receive subsystem uses this output. This output is given to the Enable TX block, which enables the transmitter buffer empty interrupt.

SampleTime

Base sample time or a multiple of the base sample time.

ID

Enter a user-defined identifier for overflow messages.

Example

The following are some examples of how you can set up the FIFO Read block:

- In the transmit side of the interrupt service routine, the maximum input port receives a value of 0 if the interrupt reason is not an empty FIFO on the board, and the FIFO size if the FIFO is empty. The minimum input port receives the constant value of 1.

On the receive side, the typical case with ASCII data has the minimum and maximum input ports disabled. The **Read to delimiter parameter** check box is selected and the **Delimiter** parameter has the value of carriage return or line feed. The value of the **Maximum read size** parameter is large (along the order of the FIFO size) and the value of **Minimum read size** parameter is 1. In this form, the driver acts like a nonblocking read line.

- An alternate receive-side configuration for fixed-length binary blocks of data has the value of the **Maximum read size** and **Minimum read size** parameters set to the fixed length of the block. The **Read to delimiter** parameter is not selected.

More About

- “RS-232 I/O Drivers” on page 2-2
- “RS-232/422/485 Drivers (Composite)” on page 2-5

External Websites

- www.bb-elec.com
- www.commtech-fastcom.com
- www.diamondsystems.com

FIFO Read HDRS (Composite)

FIFO Read HDRS block

Library

Simulink Real-Time Library for RS-232

Description

The FIFO Read HDRS block identifies and separates ASCII data streams that have embedded identifiers. The data following a particular header can have varying lengths, but has a common termination marker such as <CR><LF>. Although you can attain this same functionality with the FIFO Read/Write (Composite) block, doing so requires a complicated state machine.

Note:

- If the same header arrives in the FIFO more than once after the block was last executed, the block returns the latest instance of the header. In this way, the block catches up with data that arrives faster than the block executes.
 - If a header arrives in the FIFO that does not match an item in the headers list, the block discards the message.
 - If a message arrives in the FIFO without a header, the block interprets the message as having an unspecified header. Create and use a header for every message.
-

The `xpcdemos` folder contains the following examples that illustrate how to use the FIFO Read HDRS block: `xpcserialasciitest` and `xpcserialasciisplit`.

Block Parameters

Header

Enter the headers that you want the block to look for in a block of data from the FIFO. Enter each header as an element in a cell array.

Terminating string

Enter the terminating string for the data. Enter the characters defining the end of string, typically one or two characters.

Output behavior

From the list, select the behavior of the block if the FIFO has not received new data. Select **Zero output if no new data** if you want the block to have no output if the FIFO has no new data. Select **Hold last output if no new data** if you want the block to keep the output from the last FIFO message.

Enable input

Select this check box to turn on a new input that takes Boolean signals that enable or disable the read.

Maximum read size

Enter the largest desired read size in bytes. This parameter specifies the width of the output vector and the maximum number of elements to return. See **Output vector type** for more information about data formats.

Output vector type

From the list, select count+32 bit int, count+32 bit uint, count+16 bit int, count+16 bit uint, 8 bit int null terminated, or 8 bit uint null terminated. This parameter specifies the output vector type. The 8-bit data types produce a null terminated string in the output vector. For 16- and 32-bit data types, the first element contains the number of elements to expect in the rest of the output vector.

SampleTime

Base sample time or a multiple of the base sample time.

See Also

FIFO Read/Write (Composite)

More About

- “RS-232 I/O Drivers” on page 2-2
- “RS-232/422/485 Drivers (Composite)” on page 2-5

External Websites

- www.bb-elec.com

- www.commtech-fastcom.com
- www.diamondsystems.com

FIFO Read Binary (Composite)

FIFO Read Binary

Library

Simulink Real-Time Library for RS-232

Description

The FIFO Read Binary block reads multiple binary headers from a FIFO. This block identifies and separates data by finding unique byte sequences (headers) that mark the data. Each header indicates the start of a fixed length binary message.

Note: If the same header has arrived in the FIFO more than once since the block was last executed, the block will discard the older data and only return the latest instance of the header. In this way, the block catches up with data that arrives faster than the block executes.

The `xpcdemos` folder contains the following examples that illustrate how to use the FIFO Read HDRS block: `xpcserialbinarytest` and `xpcserialbinarysplit`.

Block Parameters

Header

Enter the headers that you want the block to look for in a block of data from the FIFO. Enter each header as an element in a cell array either as a quoted string or a concatenation with `char(val)` for non-printable byte patterns.

Message Lengths

Enter the message length of each byte of data as bytes of data. Include the header in the length.

Output behavior

From the list, select the behavior of the block if the FIFO does not have new data. Select **Zero output if no new data** if you want the block to have no output if the FIFO has no new data. Select **Hold last output if no new data** if you want the block to keep the output from the last FIFO message.

Enable input

This check box enables or disables a FIFO read. Select this check box to turn on a new input that takes Boolean signals that enable or disable the read.

Maximum read size

Enter the largest desired read size in bytes. This parameter specifies the width of the output vector and the maximum number of elements to return. See **Output vector type** for more information about data formats.

Output vector type

From the list, select **count+32 bit int**, **count+32 bit uint**, **count+16 bit int**, **count+16 bit uint**, **8 bit int null terminated**, or **8 bit uint null terminated**. This parameter specifies the output vector type. The 8-bit data types produce a null terminated string in the output vector. For 16- and 32-bit data types, the first element contains the number of elements to expect in the rest of the output vector.

SampleTime

Base sample time or a multiple of the base sample time.

More About

- “RS-232 I/O Drivers” on page 2-2
- “RS-232/422/485 Drivers (Composite)” on page 2-5

External Websites

- www.bb-elec.com
- www.commtech-fastcom.com
- www.diamondsystems.com

Modem Control (Composite)

Modem Control block

Library

Simulink Real-Time Library for RS-232

Description

The Modem Control block controls the state of either or both of the RTS and DTR output lines on the specified port.

This block requires an input of type **double**. If the input value is greater than 0.5, the block asserts the RTS or DTR control bit to true and the output goes to a positive voltage. If the value is less than or equal to 0.5, the block asserts the RTS or DTR control bit to false and the output goes to a negative voltage. If RTS or DTR is not selected, the corresponding output is not changed.

Port (Quatech, Commtech)

From the list, choose a port. The **Port** parameter defines the port to configure for this driver block.

RTS

Select this check box to control the RTS line for this board.

DTS

Select this check box to control the DTR line for this port.

Port (Diamond)

From the list, choose a port. The **Port** parameter defines the port to configure for this driver block.

First port address (Diamond)

For Emerald-MM, this value should be the same as the **First port address** parameter value you select in the Parameter Group: Board Setup dialog of the Send/Receive block. See the Diamond product documentation for information on jumper settings.

For Emerald-MM-8, this parameter contains a value based on the **Base address** value of the configuration register in the Parameter Group: Board Setup dialog of the Send/Receive block. See the Diamond product documentation.

Configuration (Mainboard)

From the list, choose a port. This parameter specifies the port whose input modem control line states you want to read.

Normally, the ports are set to the following:

COM1 — 0x3F8

COM2 — 0x2F8

COM3 — 0x3E8

COM4 — 0x2E8

A Custom port is one that is set to an address other than these.

Slot (PCI boards)

If only one board of this type is in the target computer, enter -1 to automatically locate the board.

If two or more boards of this type are in the target computer, enter the bus number and the PCI slot number of the board associated with this driver block. Use the format [BusNumber, SlotNumber]. To determine the bus number and the PCI slot number, type:

```
tg = slrt;  
getPCIInfo(tg, 'installed')
```

More About

- “RS-232 I/O Drivers” on page 2-2
- “RS-232/422/485 Drivers (Composite)” on page 2-5

External Websites

- www.bb-elec.com
- www.commtech-fastcom.com
- www.diamondsystems.com

Modem Status (Composite)

Modem Status block

Library

Simulink Real-Time Library for RS-232

Description

The Modem Status block reads the state of the four input modem control lines.

This block has an output of type **Boolean**. If the input voltage is positive, the output is true. If the input voltage is negative, the output is false.

Port (Quatech, Commtech)

From the list, choose a port. The **Port** parameter defines the port to configure for this driver block.

CTS

Select this check box to monitor the CTS line.

DSR

Select this check box to monitor the DSR line.

RI

Select this check box to monitor the RI line.

DCD

Select this check box to monitor the DCD line.

Sample time

Enter the base sample time or a multiple of the base sample time (-1 means sample time is inherited).

Port (Diamond)

From the list, choose a port. The **Port** parameter defines the port to configure for this driver block.

First port address (Diamond)

This parameter specifies the first port whose input modem control line states you want to read. Do not change this value.

For Emerald-MM, this value should be the same as the **First port address** parameter value you select in the Parameter Group: Board Setup dialog.

For Emerald-MM-8, this parameter contains a value based on the **Base address** value in the Parameter Group: Board Setup dialog.

Configuration (Mainboard)

From the list, choose a port. This parameter specifies the port whose input modem control line states you want to read.

Normally, the ports are set to the following:

COM1 — 0x3F8

COM2 — 0x2F8

COM3 — 0x3E8

COM4 — 0x2E8

A Custom port is one that is set to an address other than these.

Slot (PCI boards)

If only one board of this type is in the target computer, enter - 1 to automatically locate the board.

If two or more boards of this type are in the target computer, enter the bus number and the PCI slot number of the board associated with this driver block. Use the format [BusNumber, SlotNumber]. To determine the bus number and the PCI slot number, type:

```
tg = slrt;
getPCIInfo(tg, 'installed')
```

More About

- “RS-232 I/O Drivers” on page 2-2
- “RS-232/422/485 Drivers (Composite)” on page 2-5

External Websites

- www.bb-elec.com
- www.commtech-fastcom.com
- www.diamondsystems.com

RS-232/RS-422/RS-485 Send/Receive (Composite)

RS-232/RS-422/RS-485 Send/Receive block

Library

Simulink Real-Time Library for RS-232

Description

The dynamic dialog for these subsystem blocks allows you to perform basic board setup and setup of send/receive data. You control parameter visibility with the **Parameter Group** parameter and the port number.

There are two versions of this block, non-F and F (FIFO). Both serial boards and the main board have these two versions. The primary difference is that the F blocks bring the FIFO signal out of the subsystem:

- The non-F blocks have RCV outputs. These blocks have basic FIFO read blocks inside the subsystem. They are most useful for simple character streams. These subsystem blocks generate output as an array of packed integers (settable at 8, 16, or 32 bits) with characters in the lower byte and received status information in the upper byte.
- The F blocks have FIFO outputs. These blocks give you greater flexibility and allow you to use the FIFO read blocks.
 - FIFO Read block — A model that contains an F block in combination with the FIFO Read block provides the same capability as the non-F block.
 - FIFO Read HDRS and FIFO Read Binary — A model that contains an F block in combination with a FIFO Read HDRS or FIFO Read Binary block provides greater capability than the FIFO Read block. See [FIFO Read HDRS \(Composite\)](#) and [FIFO Read Binary \(Composite\)](#).

Only one Send/Receive block can exist for each interrupt. All ports that use that interrupt must be associated with that block.

For example, if you have four ports configured on the main board, COM1 and COM3 typically share an interrupt. In this case, COM1 and COM3 must then share the

same Send/Receive block. COM1 is also of note because you can use it for linking the development and target computers. If COM1 is used for the serial link, neither COM1 nor COM3 can be used with this block as long as they share an interrupt. The same is true for COM2 and COM4.

The **Board Setup** and **Basic Setup** configuration parameter options for F-Send-Receive blocks are the same as for their non-F Send Receive block counterparts. To provide direct access to the board, these blocks also have a **FIFO Setup** parameter option. The following descriptions merge the common elements and call out the differences among the different blocks.

Block Parameters

Parameter Group

This parameter allows you to choose which subset of configuration parameters you want to modify. Possible values are:

- Board Setup
- Basic Setup
- Transmit Setup
- Receive Setup
- FIFO Setup

The configuration parameter subsets are:

Board Setup

The **Parameter Group** **Board Setup** option is supported by both F and non-F Send Receive blocks.

Configuration (Mainboard)

From the list, choose combinations of port pairs (Com1 / none, Com2 / none, Com1 / Com3, Com2 / Com4, none / Com3, none / Com4, or Custom). This parameter specifies the ports for which you are defining transmit and receive. A Custom port is one that does not match the existing combinations of port pairs. For example, you can set the IRQ and two addresses or, if one of the ports is not used, set that to 0.

IRQ number (Quatech, Commtech)

Enter the number of the interrupt request line for this board. If you do not know the interrupt request line number for this board, at the MATLAB Command Window, enter:

```
tg = slrt;
getPCIInfo(tg, 'installed')
```

This command displays the PCI interfaces currently attached to the target computer. From that display, find the instance of the board controlled by this block. Each board uses a unique interrupt request line number.

For Emerald-MM, set this to the IRQ chosen by jumpers on the board. Set the four ports to the same IRQ.

For Emerald-MM-8, this block setting programs the board IRQ.

(Diamond) Not all IRQ values work in all target computer machines. You should experiment to find a working combination.

Clock Bits (Commtech)

Enter the number of click bits to control a clock generator common to both channels. This parameter adjusts the master clock of both channels. Calculate this parameter using the function `fc422mexcalcbits`.

Master Clock Frequency (Commtech Fastcom 422/2-PCI-335, 422/4-PCI-335)

Enter the clock generator frequency for the master clock. Enter a value between 6 MHz and 50 MHz, inclusive.

Use standard reference and rates (Commtech Fastcom 422/2-PCI-335, 422/4-PCI-335)

This check box enables you to use default values for the block. Select this check box to use the default values for the **Master Clock Frequency** parameter. If you clear this check box, you can enter a custom value for the **Master Clock Frequency** parameter. This same check box also appears on the **Basic Setup** option page for all ports. Selecting this box applies to all channels.

Slot (PCI boards)

If only one board of this type is in the target computer, enter -1 to automatically locate the board.

If two or more boards of this type are in the target computer, enter the bus number and the PCI slot number of the board associated with this driver block. Use the

format [BusNumber, SlotNumber]. To determine the bus number and the PCI slot number, type:

```
tg = slrt;  
getPCIInfo(tg, 'installed')
```

Base address (Diamond Emerald-MM-8)

Enter the base address of the board that you are setting up. This is the address of the configuration register on the board. The first port address referenced in Modem Control and Modem Status blocks is offset 0x10 from the configuration register address, and each subsequent port address is offset 0x8 from that.

You must set the configuration register address on the board with a jumper. You can set the configuration register address to one of the following addresses: 0x100, 0x140, 0x180, 0x1c0, 0x200, 0x240, 0x280, 0x2c0, 0x300, 0x340, 0x380, or 0x3c0. Note that the Simulink Real-Time software assigns successive 8 byte addresses to the eight UARTs even though the I/O module allows random placement.

Be sure that these addresses do not conflict with the COM port addresses listed in “Adding RS-232 Blocks” on page 2-6. If you set the configuration register address to 0x2c0, it conflicts with COM2. If you set the configuration address to 0x3c0, it conflicts with COM1.

First port address (Diamond Emerald-MM)

From the list, select the first port address for the board. This address is the first of four port addresses for the Emerald-MM board. You must initially set this address on the board with a jumper. The remaining three addresses follow consecutively in increments of 0x8. Be sure that these addresses do not conflict with the COM port addresses listed in “Adding RS-232 Blocks” on page 2-6.

Basic Setup

The **Parameter Group Basic Setup** option is supported by both F and non-F Send Receive blocks.

Port to modify

From the list, choose a port. The **Port to modify** parameter specifies the port for which you want to view or modify the parameters.

For Baseboard drivers, the port is the Simulink block port, where the upper port is 1 and the lower port is 2. For other drivers, the port number corresponds to the channel number.

Use standard reference and rates (Commtech Fastcom 422/2-PCI-335, 422/4-PCI-335)

This check box enables you to use default values for the block. Select this check box to use the default values for the **Baud divisor** and **Sampling rate** parameters. Selecting this check box allows you to enter a value for the **Baud rate** parameter and also selects the **Prescale** parameter. If you clear this check box, you can enter custom values for the **Baud divisor** and **Sampling rate** parameters, but must use the default value for the **Baud rate** parameter. Clearing this check box also clears the **Prescale** check box.

If selected:

- Reference is set to 14.7456 MHz.
- **Prescale** is disabled.
- Sampling rate is 16X (standard).
- Select the baud rate from **Baud Rate**.

If not selected, you must provide a custom baud rate that is not on the drop-down list to get the desired reference. For example, if you have a desired baud rate of 1.0 MHz, you can use the following equation to calculate the reference:

$$\text{reference} = \text{baud rate} \times \text{sampling rate} \times \text{divisor} \times \text{prescale}$$

The following values give an acceptable reference that is less than or equal to 50 MHz.

$$\text{reference} = 1.10\text{e}6 \times 16 \times 1 \times 1 = 16 \text{ MHz}$$

Baud Divisor (Commtech)

Enter a divisor integer. The block determines the actual baud rate for a particular channel by dividing the maximum baud rate by this divisor. This number can be different for each channel.

Baud rate (Mainboard, Quatech, Diamond, (Commtech Fastcom 422/2-PCI-335, 422/4-PCI-335))

From the list, choose a baud rate.

(Diamond Emerald-MM) The Emerald-MM block lists the baud rates with an HS label to indicate the rate if the board contains the high speed crystal option.

Sampling rate (Commtech Fastcom 422/2-PCI-335, 422/4-PCI-335)

From the list, select **8x** or **16x** (standard) per port. This parameter is enabled if you clear the **Use standard reference and rates** parameter.

Prescale (Commtech Fastcom 422/2-PCI-335, 422/4-PCI-335)

For very slow baud rates, you might need to enable this divide by 4 prescaler to achieve the desired rate. In most cases, you do not need to enable this.

Parity

From the list, choose **None**, **Even**, **Odd**, **Mark**, or **Space**. This parameter defines the parity.

Data bits

From the list, choose either 5, 6, 7, or 8 to select the number of bits per character.

Stop bits

From the list, choose either 1 or 2 to define the number of stop bits for the port. Most modern RS-232 boards work fine with a character stream that uses single (1) stop bits.

Hardware FIFO size (Quatech, Diamond)

From the list, choose either 64 deep, 16 deep, or 1 deep. This parameter specifies the size of the FIFO in the UART. The **Hardware FIFO size** parameter affects both the receive and transmit FIFOs. For example, specifying a FIFO size of 64 bytes results in fewer interrupts. Fewer interrupts can allow more processing to occur in the model.

The types of UARTs include

16450 — Maximum 1 byte depth

16550 — Maximum 16 byte FIFO depth

16750 — Maximum 64 byte FIFO depth

Receive FIFO interrupt level

From the list, choose **1**, **quarter full**, **half full**, or **almost full**. This parameter specifies the number of characters in the Receive FIFO before an interrupt occurs. Receive interrupts occur at least as often as this parameter specifies.

If a gap of at least 4 character times, the span of four characters, occurs in a data stream, the UART requests an interrupt for the receiver. The UART requests an interrupt regardless of the value of **Receive FIFO interrupt level**. If the FIFO on the board contains at least one character, an interrupt is signaled.

(Commtech) The Fastcom 422/2-PCI and Fastcom 422/2-PCI F blocks do not have this parameter as a drop-down list. Instead, these blocks allow you to enter an arbitrary number of bytes up to the FIFO size, with 64 as the default. Typically, 8 to 16 bytes is large enough, but the size you choose depends on the speed of the incoming characters. Be careful that you do not enter a size that causes too many interrupts.

Auto RTS/CTS (RS-232 boards)

Select this check box to enable the RTS/CTS handshake for flow control. This RTS/CTS handshake feature of the UART is used to prevent data loss due to FIFO overflow on the board.

Because of the large 64 byte FIFO in the I/O module, flow control that is based on software control in the interrupt service routine can have problems. In most cases, the interrupt service routine executes quickly enough to empty the FIFO. However, if you get FIFO overruns, select this check box.

Assert on transmit (RS-422/485 boards)

From the list, select **None**, **RTS**, or **DTR** to specify the state of the RTS or DTR line. The driver asserts the selected line upon transmission.

Hardware handshake (Commtech Fastcom 422/2-PCI-335, 422/4-PCI-335)

Enable the RTS/CTS handshake for flow control. This feature of the UART is used to prevent loss due to FIFO overflow. From the list, select **RTS/CTS** to enable this behavior; otherwise, select **none**.

Software handshake (Commtech Fastcom 422/2-PCI-335, 422/4-PCI-335)

Allows the UART to send the **XOFF** character if the receive FIFO gets too full. It then sends the **XON** character when the receive FIFO empties. Because the UART handles this, the **XON/XOFF** characters are sent immediately, even if the transmitter is empty. From the list, select **XON/XOFF** to enable this behavior; otherwise, select **none**.

XON character (Commtech Fastcom 422/2-PCI-335, 422/4-PCI-335)

Normally, enter **17 (Control Q)**. This is the default.

XOFF character (Commtech Fastcom 422/2-PCI-335, 422/4-PCI-335)

Normally, enter **19 (Control S)**. This is the default.

RS485 auto turnaround (Commtech Fastcom 422/2-PCI-335, 422/4-PCI-335)

Select this check box to enable RS-485 automatic turnaround. In RS-485 mode, where the transmitters and receivers use the same differential pair of wires, you can enable only one transmitter at a time. Select this check box to turn on the automatic

transmitter control in the UART. The RTS output is routed to the enable input of the RS-485 transmitter.

RS485 turnaround delay (Commtech Fastcom 422/2-PCI-335, 422/4-PCI-335)

Enter the desired RS-485 turnaround delay. The UART automatically asserts RTS when there are characters in the transmit FIFO. It de-asserts RTS when the transmit FIFO empties and the RS-485 turnaround default delay of 0 to 15 bit times elapses. The transmitter output goes tristate (high impedance) when disabled, which allows another device to transmit.

Transmit Setup

The **Parameter Group** Transmit Setup option is supported by only non-F Send Receive blocks.

Port to modify

From the list, choose a port. The **Port to modify** parameter specifies the port for which you want to view or modify the parameters.

Use standard reference and rates (Commtech Fastcom 422/2-PCI-335, 422/4-PCI-335)

This check box enables you to use default values for the block.

Transmit software FIFO size

Enter the transmit software FIFO size, in bytes. This parameter specifies the size of the software FIFO used to buffer transmitted characters.

Transmit FIFO data type

From the list, choose `count+32 bit int`, `count+32 bit uint`, `count+16 bit int`, `count+16 bit uint`, `8 bit int null terminated`, or `8 bit uint null terminated`. This parameter specifies the data type of the transmitter. The 8-bit data types require a NULL-terminated string in the input vector.

The 16- and 32-bit data types reserve the first full element to contain the number of elements to expect in the rest of the input vector. Only the low-order byte of each data element is sent. Setting this data type allows a wider data type to hold the bytes.

If the data stream needs to include a NULL byte, you must select one of the 16- or 32-bit data types. Because the 8-bit data types are NULL terminated strings, the NULL byte would terminate the string.

Receive Setup

The **Parameter Group Receive Setup** option is supported by only non-F Send Receive blocks.

Port to modify

From the list, choose a port. The **Port to modify** parameter specifies the port for which you want to view or modify the parameters.

Use standard reference and rates (Commtech Fastcom 422/2-PCI-335, 422/4-PCI-335)

This check box enables you to use default values for the block. Select this check box to use the default values for the **Baud divisor** and **Sampling rate** parameters. Selecting this check box allows you to enter a value for the **Baud rate** parameter and also selects the **Prescale** parameter. If you clear this check box, you can enter custom values for the **Baud divisor** and **Sampling rate** parameters, but must use the default value for the **Baud rate** parameter. Clearing this check box also clears the **Prescale** check box.

If selected:

- Reference is set to 14.7456 MHz.
- **Prescale** is disabled.
- Sampling rate is 16X (standard).
- Select the baud rate from **Baud Rate**.

If not selected, you must provide a custom baud rate that is not on the drop-down list to get the desired reference. For example, if you have a desired baud rate of 1.0 MHz, you can use the following equation to calculate the reference:

$$\text{reference} = \text{baud rate} \times \text{sampling rate} \times \text{divisor} \times \text{prescale}$$

The following values give an acceptable reference that is less than or equal to 50 MHz.

$$\text{reference} = 1.10\text{e}6 \times 16 \times 1 \times 1 = 16 \text{ MHz}$$

Receive software FIFO size

Enter the size of the receive software FIFO, in bytes. This parameter specifies the size of the software FIFO to buffer characters between interrupt service and periodic execution.

Receive maximum read

Enter the maximum number of elements that you want returned by a single call to this block. This parameter is also used to set the output vector width. If the **Read to delimiter** check box is selected, the maximum number of characters read is limited by this parameter even if the delimiter is not found.

Receive minimum read

Enter the minimum number of characters to read. If the FIFO does not contain at least this number of characters, the output vector is empty.

Read to delimiter

Select this check box to have this block return all characters in the FIFO, up to and including the specified delimiter. If the block does not find the delimiter in the FIFO, it returns nothing.

If the buffer has errors, such as framing errors, characters are returned regardless of the presence of the delimiter. This special case helps diagnose errors such as mismatched baud rates.

Delimiter

Enter the numeric value of the character that is the message delimiter. Any value from 0 to 255 is valid. The common case looks for 10 (line feed) or 13 (carriage return).

Receive data type

From the list, select `count+32 bit int`, `count+32 bit uint`, `count+16 bit int`, `count+16 bit uint`, `8 bit int null terminated`, or `8 bit uint null terminated`. This parameter specifies the data type of the receiver. The 8-bit data types produce a null terminated string in the output vector. For 16- and 32-bit data types, the first element contains the number of valid elements in the rest of the output vector.

For 8-bit data types, only the character data is in the output vector, and a NULL terminator is appended. The 16- or 32-bit wide data types cause the error status from the UART to be placed in the second byte of each data element. (The error status contains the parity, overrun, framing, and break bits.) The character data is in the bottom eight bits of each element; the first element of the vector contains the number of data elements that follow.

Receive SampleTime

Base sample time or a multiple of the base sample time.

FIFO Setup

The **Parameter Group** FIFO Setup option is supported by only F Send Receive blocks.

Port to modify

From the list, choose port 1 or 2. The **Port to modify** parameter specifies the port for which you want to view or modify the parameters.

Transmit software FIFO size

Enter the transmit software FIFO size, in bytes. This parameter specifies the size of the software FIFO used to buffer transmitted characters.

Transmit FIFO data type

From the list, choose `count+32 bit int`, `count+32 bit uint`, `count+16 bit int`, `count+16 bit uint`, `8 bit int null terminated`, or `8 bit uint null terminated`. This parameter specifies the data type of the transmitter. The 8-bit data types require a NULL-terminated string in the input vector.

The 16- and 32-bit data types reserve the first full element to contain the number of elements to expect in the rest of the input vector. Only the low-order byte of each data element is sent. Setting this data type allows a wider data type to hold the bytes. If the data stream needs to include a NULL byte, you must select one of the 16- or 32-bit data types.

Receive software FIFO size

Enter the size of the receive software FIFO, in bytes. This parameter specifies the size of the software FIFO to buffer characters between interrupt service and periodic execution.

See Also

`fc422mexcalcbits` | FIFO Read Binary (Composite) | FIFO Read HDRS (Composite)

More About

- “RS-232 I/O Drivers” on page 2-2
- “RS-232/422/485 Drivers (Composite)” on page 2-5

External Websites

- www.bb-elec.com

- www.commtech-fastcom.com
- www.diamondsystems.com

RS232 State (Composite)

RS232 State block

Library

Simulink Real-Time Library for RS-232

Description

The RS232 State block monitors the board state information that is present in the vector coming out of a receive port on a send/receive block.

The input data vector can be one of `Int8`, `UInt8`, `Int16`, or `UInt16`. If the input vector is `Int8` or `UInt8`, no error status is available and the Boolean outputs are false. If the input vector is `Int16` or `UInt16`, the upper byte should contain the error status bits from the UART.

This block accumulates errors over the whole input vector. An output error state is true if it is true for any byte in the input vector.

The `FIFO Hardware FIFO` block puts the UART status in 16+32 bit data streams. The `RS232 State` block looks at this status. Note that only the `FIFO Read` block passes this status information to its output port.

Block Parameters

Overrun error output

Select this check box to retrieve overrun error output. This output is true if the FIFO in the UART was filled while a character in the input vector was being received.

Parity error output

Select this check box to retrieve parity error output. This output is true if any byte in the input vector fails the parity check.

Framing error output

Select this check box to retrieve framing error output. This output is true if a framing error occurs on any character in this vector. For example, a framing error might occur if the baud rates between the transmitter and receiver do not match.

Break interrupt output

Select this check box to retrieve break interrupt output. A break interrupt output is not an error, but the UART treats it like an error state. The break condition is detected if the serial line remains at logic 0 (negative voltage) for more than one character time.

Note: For some serial I/O port modules, disconnecting the serial cable does not cause a break.

More About

- “RS-232 I/O Drivers” on page 2-2
- “RS-232/422/485 Drivers (Composite)” on page 2-5

External Websites

- www.bb-elec.com
- www.commtech-fastcom.com
- www.diamondsystems.com

Serial Communications Support: Internal Blocks

RS-232/422/485 Enable TX Interrupt (Composite)

RS-232/422/485 Enable TX Interrupt block

Library

Simulink Real-Time Library for RS232

Description

The Enable TX Interrupt block enables the transmitter buffer empty interrupt when data is present in the software FIFO.

The input port for controlling this is a Boolean value. If the input port value is true, the Enable Transmit Interrupt block enables the transmitter buffer empty interrupt in the UART. After the interrupt service routine empties the software FIFO, the interrupt is disabled.

Block Parameters

Base address (Mainboard, ISA boards)

Enter the base address of the UART for which you want to enable the transmitter buffer empty interrupt.

Port (Quatech, Commtech)

From the list, choose a port. This parameter specifies the input port for which this block enables the interrupt.

Slot (PCI boards)

If only one board of this type is in the target computer, enter - 1 to automatically locate the board.

If two or more boards of this type are in the target computer, enter the bus number and the PCI slot number of the board associated with this driver block. Use the format [BusNumber, SlotNumber]. To determine the bus number and the PCI slot number, type:

```
tg = slrt;  
getPCIInfo(tg, 'installed')
```

More About

- “RS-232 I/O Drivers” on page 2-2
- “RS-232/422/485 Drivers (Composite)” on page 2-5

External Websites

- www.bb-elec.com
- www.commtech-fastcom.com
- www.diamondsystems.com

RS-232/422/485 Filter Interrupt Reason (Composite)

RS-232/422/485 Filter Interrupt Reason block

Library

Simulink Real-Time Library for RS232

Description

The Filter Interrupt Reason block filters the output of the Read Int(errupt) Status block. If the condition that the interrupt query block reads from the IIR register matches the one chosen here, the output is true.

This block is used exclusively inside the interrupt service subsystem for this board.

Block Parameters

Port

From the list, choose a port. This parameter specifies the port from which this block gets control data.

Filter value

From the list, choose **Receive data**, **Transmitter empty**, or **Modem status change**. This parameter specifies the interrupt reason that this filter block is looking for.

Note that **Modem status change** currently does nothing because the interrupt is not enabled.

More About

- “RS-232 I/O Drivers” on page 2-2
- “RS-232/422/485 Drivers (Composite)” on page 2-5

External Websites

- www.bb-elec.com
- www.commtech-fastcom.com
- www.diamondsystems.com

RS-232/422/485 Read Hardware FIFO (Composite)

RS-232/422/485 Read Hardware FIFO block

Library

Simulink Real-Time Library for RS232

Description

The `Read Hardware FIFO` block reads characters from the I/O module FIFO in the UART. It then outputs those characters as the low-order byte of an unsigned 32-bit integer vector with a width of 65. This output vector is large enough to hold the maximum number of characters that the FIFO can hold. The first element of the vector specifies the number of data elements in the remainder of the vector.

If the input to the enable port (input port, labeled E) is not true, this block outputs a 0 length vector. The following illustrates the vector.

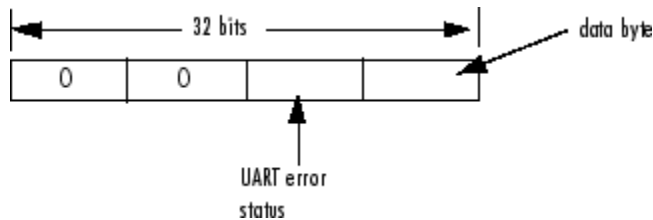

The UART error status can contain one of the following error values:

0x02 — Overrun error

0x04 — Parity error

0x08 — Framing error

0x01 — Break interrupt

The data byte ranges from 0 to 255.

The dialog box for the RS-232 FIFO Read block contains the following fields:

Block Parameters

Port (Quatech, Commtech)

From the list, choose a port. This block reads the FIFO from this port.

Flush HW FIFO on startup

Select this check box to flush the FIFO when the device starts up.

Base address (Mainboard, ISA boards)

Enter the base address of the UART for which you want to read the FIFO.

Slot (PCI boards)

If only one board of this type is in the target computer, enter - 1 to automatically locate the board.

If two or more boards of this type are in the target computer, enter the bus number and the PCI slot number of the board associated with this driver block. Use the format [BusNumber, SlotNumber]. To determine the bus number and the PCI slot number, type:

```
tg = slrt;  
getPCIInfo(tg, 'installed')
```

More About

- “RS-232 I/O Drivers” on page 2-2
- “RS-232/422/485 Drivers (Composite)” on page 2-5

External Websites

- www.bb-elec.com
- www.commtech-fastcom.com
- www.diamondsystems.com

RS-232/422/485 Read Int(errupt) Status (Composite)

RS-232/422/485 Read Int(errupt) Status

Library

Simulink Real-Time Library for RS232

Description

The Read Interrupt Status block reads the interrupt status for the boards in the system. The output for this block is a vector with one 32-bit element for each port. Each element contains two pieces of information for that port, where the four bytes are

[0, 0, IIR, Reason]

The Read Interrupt Status block has signal output with the following format:

This output is a vector of integers. The values in the reason byte and their definitions are

0 — This UART did not cause this interrupt.

1 — Receive characters are available.

2 — Transmit holding register is empty.

3 — Modem status has changed (ignored).

This second byte is the value read from the Interrupt Reason Register (IIR). This register is specific to the 16450, 16550, and 16750 types of UARTs. Several bits in this register indicate the active FIFO depth and the maximum number of characters that can be written in the transmitter empty interrupt handlers to the transmit FIFO.

Block Parameters

Base address 1 (Mainboard, ISA boards)

Enter the base address of the first UART for which you want to read the interrupt status.

Base address 2 (Mainboard, ISA boards)

Enter the base address of the second UART for which you want to read the interrupt status.

Slot (PCI boards)

If only one board of this type is in the target computer, enter - 1 to automatically locate the board.

If two or more boards of this type are in the target computer, enter the bus number and the PCI slot number of the board associated with this driver block. Use the format [BusNumber, SlotNumber]. To determine the bus number and the PCI slot number, type:

```
tg = slrt;
getPCIInfo(tg, 'installed')
```

First to Fourth port address (Diamond-MM)

These parameters contain the address of the port for which you want to read the interrupt status.

Starting from the **First port address** parameter value you select in the Parameter Group: Board Setup dialog of the Send/Receive block, the subsequent parameters contain the incremental port addresses.

First to Eighth port address (Diamond-MM-8)

These parameters contain the addresses of the ports for which you want to read the interrupt status.

Starting from the **Base address** parameter value in the Parameter Group: Board Setup dialog of the Send/Receive block, the subsequent parameters contain the incremental port addresses.

Interrupt status address (Diamond)

This parameter contains the address for the interrupt status. This parameter derives from the configurations you define in the Parameter Group dialog of the Send/Receive block.

More About

- “RS-232 I/O Drivers” on page 2-2

- “RS-232/422/485 Drivers (Composite)” on page 2-5

External Websites

- www.bb-elec.com
- www.commtech-fastcom.com
- www.diamondsystems.com

RS-232/422/485 Setup (Composite)

RS-232/422/485 Setup block

Library

Simulink Real-Time Library for RS232

Description

A setup block is a subsystem block that sets up the interface characteristics for the board.

For Quatech boards, this setup block is for one channel or port.

Block Parameters

Port (Quatech, Commtech)

From the list, choose a port. The **Port** parameter defines the port this driver block configures.

Baud Divisor (Commtech)

Enter a divisor integer. The block determines the actual baud rate for a particular channel by dividing the maximum baud rate by this divisor. This number can be different for each channel.

Baud rate (Mainboard, Quatech, Diamond)

From the list, choose a baud rate.

Number of data bits

From the list, choose either 5, 6, 7 or 8 to define the number of data bits for the port.

Number of stop bits

From the list, choose either 1 or 2 to define the number of stop bits for the port.

Parity

From the list, choose None, Even, Odd, Mark or Space. This parameter defines the receive and transfer parity.

Fifo mode (Mainboard, Quatech, Diamond)

From the list, choose **64 deep**, **16 deep**, or **1 deep**. This parameter sets the transmit and receive FIFO depth. The UART can operate with a FIFO depth of 1 character (1 deep), 16 characters (16 deep), or 64 characters (64 deep).

Receive trigger level

From the list, choose **1**, **quarter full**, **half full**, or **almost full**. This parameter defines a trigger level for a receive data available interrupt. When the FIFO reaches the level specified in this parameter, the driver asserts the receive data available interrupt.

Enable auto RTS/CTS

Select this check box to enable handshaking using the RTS and CTS modem control lines. If this is not checked, handshaking is not done.

Base Address (Mainboard, ISA, or Diamond)

Enter the base address of the board that you are setting up.

For Diamond-MM-8 boards, this block uses the base address you enter for the Send/Receive block.

IRQ (Diamond-MM-8)

This field contains the value of the **IRQ number** parameter from the **Parameter Group: Board Setup** of the Send/Receive block.

For Emerald-MM-8, this block setting programs the board IRQ.

Slot (PCI boards)

If only one board of this type is in the target computer, enter -1 to automatically locate the board.

If two or more boards of this type are in the target computer, enter the bus number and the PCI slot number of the board associated with this driver block. Use the format [BusNumber, SlotNumber]. To determine the bus number and the PCI slot number, type:

```
tg = slrt;  
getPCIInfo(tg, 'installed')
```

More About

- “RS-232 I/O Drivers” on page 2-2

- “RS-232/422/485 Drivers (Composite)” on page 2-5

External Websites

- www.bb-elec.com
- www.commtech-fastcom.com
- www.diamondsystems.com

RS-232/422/485 Board Setup (Commtech) and Interrupt Check (Quatech) (Composite)

RS-232/422/485 Board Setup (Commtech) and Interrupt Check (Quatech) block

Library

Simulink Real-Time Library for RS232

Description

(Quatech and Commtech only) The Board Setup and Interrupt Check block checks for instances where the IRQ differs from the software for which it is listening. This block compares the software-selected interrupt against the value for which the board (PCI only) is configured. This check prevents IRQ mismatches. For the Commtech Fastcom board, the corresponding block also sets up the board clock.

Block Parameters

PCI slot

If only one board of this type is in the target computer, enter -1 to locate the board.

If two or more boards of this type are in the target computer, enter the bus number and the PCI slot number of the board associated with this driver block. Use the format **[BusNumber, SlotNumber]**. To determine the bus number and the PCI slot number, type:

```
tg = slrt;  
getPCIInfo(tg, 'installed')
```

Clock Bits (Commtech)

Enter the number of clock bits to control a clock generator common to both channels. This parameter adjusts the master clock of both channels.

IRQ Line Number

From the list, select an IRQ line number from 5 to 15, inclusive.

More About

- “RS-232 I/O Drivers” on page 2-2
- “RS-232/422/485 Drivers (Composite)” on page 2-5

External Websites

- www.bb-elec.com
- www.commtech-fastcom.com
- www.diamondsystems.com

RS-232/422/485 Write Hardware FIFO (Composite)

RS-232/422/485 Write Hardware FIFO block

Library

Simulink Real-Time Library for RS232

Description

The `Write Hardware FIFO` block writes the data from the input port (labeled `E`) to the FIFO in the I/O module UART for this port. The following pseudocode describes the behavior of this FIFO.

```
if (enable is false)
    return
else
    {
        if (input data empty)
            disable transmitter buffer empty interrupt
            return
        else
            copy input data to HW FIFO
    }
```

In words: if the input to the enable port (input port, labelled `E`) is `true` and the input data has length `0`, then the block turns off the transmitter buffer empty interrupt. Otherwise, the block adds input data to the FIFO.

Block Parameters

Base address (Mainboard, ISA boards)

Enter the base address of the UART for which you want to write the FIFO.

For Diamond-MM-8 boards, this block uses the base address you enter for the Send/Receive block.

Port

From the list, choose a port. This is the port to which this block writes data.

Assert on Transmit (RS-422/485 boards)

Select None, RTS, or DTR. The board asserts no bit, the RTS bit, or the DTR bit in the modem control register upon data transmission.

For half duplex operation, set the jumper on the board to send either RTS or DTR signals to the transmit enable gate. See the board documentation for further information.

Slot (PCI boards)

If only one board of this type is in the target computer, enter -1 to automatically locate the board.

If two or more boards of this type are in the target computer, enter the bus number and the PCI slot number of the board associated with this driver block. Use the format [BusNumber, SlotNumber]. To determine the bus number and the PCI slot number, type:

```
tg = slrt;  
getPCIInfo(tg, 'installed')
```

More About

- “RS-232 I/O Drivers” on page 2-2
- “RS-232/422/485 Drivers (Composite)” on page 2-5

External Websites

- www.bb-elec.com
- www.commtech-fastcom.com
- www.diamondsystems.com

CAN, Ethernet, EtherCAT

CAN I/O Support

- “CAN Basics” on page 4-2
- “Supported Softing Boards” on page 4-6
- “Model Execution Driven by CAN Messages” on page 4-8
- “Initialization and Termination CAN Messages” on page 4-11
- “CAN Data Frames” on page 4-13
- “Timeouts When Receiving CAN Messages” on page 4-14

CAN Basics

In this section...

“Simulink Real-Time CAN Library” on page 4-2

“Data Types” on page 4-3

“Sending and Receiving Remote Frames” on page 4-4

Simulink Real-Time CAN Library

The Simulink Real-Time block library offers support to connect a target computer to a CAN network using the CAN driver blocks provided by the Simulink Real-Time I/O CAN block library. This support is for I/O device drivers for the CAN-AC2-ISA and CAN-AC2-PCI boards from Softing GmbH (Germany). The CAN driver library allows Simulink Real-Time applications to connect to an arbitrary CAN field bus network for I/O communication or real-time target-to-target communication.

These drivers support CAN specifications 2.0A and 2.0B and use the dynamic object mode of the CAN-AC2 firmware to achieve real-time performance.

The Simulink Real-Time CAN library intentionally restricts its support to Softing boards with two CAN ports. To test the PCI and PC/104 boards, see the `xpcdemos` folder for simple loopback test models. Type the following commands to open the corresponding models, which use `CAN_MESSAGE` data types.

CAN-AC2-PCI Example	Description
“CAN I/O - Simple Use Case” — CAN_MESSAGE data type	Shows simple CAN I/O communication.
“CAN I/O - Message-Based Interrupts” — CAN_MESSAGE data type	Shows asynchronous message-based event support using interrupt driven CAN I/O communication.

The size of the driver code of the CAN boards supported by the Simulink Real-Time block library is significant. Because not all Simulink Real-Time applications will use CAN, the CAN library code is not linked by default when building a real-time application. This non-linking makes real-time applications smaller if CAN communication functionality

is not required. If the model to be built contains CAN driver blocks, Simulink Real-Time links in the CAN library code required to run the model.

For each CAN board three driver blocks are provided:

- **Setup** block — Defines the type of physical connection (baud rate and so forth). Exactly one instance of the **Setup** block must be defined in a model for each physically installed CAN board.
- **Send** block — Transmits (sends) the data entering the block's input ports to the connected CAN network. One or more instances of the **Send** block can be used in a model.
- **Receive** block — Retrieves (reads) CAN messages received by the board and outputs the data at the corresponding output ports. One or more instances of the **Receive** block can be used in a model.

Drivers for the supported CAN boards program the boards for the so-called *dynamic object mode*. This is one of three modes the CAN board firmware from Softing can operate in. For a more detailed discussion of the three modes see the board's user manual. Dynamic object mode is best suited for real-time environments where each component of the application must have deterministic time behavior. This is the case for the Simulink Real-Time product, and that is the main reason why this mode has been chosen over the other two modes, which are FIFO and static object mode. In this mode, you use a separate port for each ID that you are sending or receiving. The blocks for these boards send messages in priority order, from the lowest ID to the highest.

Data Types

The Simulink Real-Time CAN blocks support the following message data types. If you have Softing ISA CAN boards, you can use only the double data type for messages. If you have Softing PCI and PC/104 CAN boards, you can use either CAN_MESSAGE or double data types data types for new messages.

- **CAN_MESSAGE** — Structure that contains an array of eight unsigned 8-bit integers that contains the data. This array also contains the ID, and the standard and extended ID range. CAN blocks can pass data of this type without having to manipulate it, enabling you to create simpler models. Use messages of this data type for new CAN application models. Consider updating existing CAN application models to use CAN_MESSAGE data types.

Use **CAN Pack** blocks to pack individual signals into a CAN message for sending. Use **CAN Unpack** blocks to unpack individual signals from CAN messages,

You can construct a `CAN_MESSAGE` by using the `CAN Pack`. You can use this block to pass raw data packed elsewhere, by packing a data pattern manually. You can also use a `CANDB` file and select a predefined data pattern.

- **Double** — Double that represents 8 bytes of message in a signal. CAN blocks manipulate data of this type before passing it. Do not use this data type to create new CAN application models. The maximum size of the data frame of a CAN message is 8 bytes. This size is the same as the C data type `double` uses on PC-compatible systems. At the same time, the double data type is the default data type for Simulink signals. Represent the CAN data frame within a Simulink model with a scalar Simulink signal. You can represent the data frame even if the data frame has nothing in common with a double floating-point value. The Simulink Real-Time CAN library provides a Utility sublibrary that offers bit-packing and bit-unpacking blocks. Use these blocks to pack data types other than doubles into 64 bits (8 bytes or a double) as well as for the opposite operation. Simulink signals of data type `double` represent CAN data frames.

Updating Existing Models to Use `CAN_MESSAGE` Data Types

If you have Softing PCI and PC/104 CAN boards, you can update existing models to use `CAN_MESSAGE` data types. As a rule:

- If your existing models contain `CAN Bit-Packing` and `CAN Bit-Unpacking` blocks, replace them with the `CAN Pack` and `CAN Unpack` blocks.
- Open and reconfigure the `CAN Send` and `Receive` blocks to use `CAN_MESSAGE` data types.
- Remove object mode `CAN Message` and `CANDBC Translator` blocks. Updated models do not require the conversions that these blocks perform.

Sending and Receiving Remote Frames

Ordinarily, a subsystem sends its value over the CAN bus according to its own schedule, and another subsystem stores that value for use whenever downstream processing requires it. Under some circumstances, a subsystem explicitly requests the current value from another subsystem. This process is called sending a remote frame.

- To prepare a remote frame, use the `CAN Pack` block with the **Remote frame** check box selected. To request the current value, send the remote frame to the responding subsystem.

- To process a remote frame, use the **CAN Unpack** block with the **Output remote** check box selected to enable the Remote port. When the Remote port becomes `true`, send the current value to the requesting subsystem.

Supported Softing Boards

The library supports the following CAN boards from Softing GmbH, Germany.

Board Name	Form Factor	Identifier Range	Multiple Board Support
CAN-AC2-PCI	PCI	Standard & Extended	Yes (up to 16)
CAN-AC2-104	PC/104	Standard & Extended	Yes (up to 3)

For more information on the board specifications, visit company.softing.com/en.

- **CAN-AC2-PCI**

CAN board for the PCI bus offering two CAN ports. The CAN controllers on the board are the SJA1000 from Philips. In its standard configuration, the board is designed for both standard and extended identifiers for high-speed CAN. Piggyback modules are available (one for each port) that add low-speed CAN support to switch between high-speed and low-speed CAN. The board is a memory-mapped PCI device that uses 64 KB of address space. The address space is assigned automatically by the PCI BIOS of the target computer and lies usually in the range between 2 GB and 4 GB. New projects using a desktop computer as the target system should use this board and not the ISA board.

- **CAN-AC2-104**

CAN board for the PC/104 bus offering two CAN ports. The CAN controllers on the board are the SJA1000 from Philips. The board offers both standard and extended identifiers for high-speed CAN. A low-speed CAN extension is not available. The board is both I/O mapped and memory mapped. The I/O-mapped area uses a 4 byte I/O address range. The memory-mapped area uses a 4 KB address range between 640 KB and 1 MB.

CAN-AC2-PCI with SJA1000 Controller

The CAN-AC2-PCI driver blocks support the Softing CAN-AC2-PCI. The Philips SJA1000 chip is used as the CAN controller in this configuration and supports both standard and extended identifier ranges in parallel. The driver block set for this board is found in the Simulink Real-Time I/O block library in the group CAN/Softing.

The CAN-AC2-PCI SJA 1000 block group contains the three available CAN blocks:

- Softing CAN-AC2-PCI with SJA1000 Setup
- Softing CAN-AC2-PCI with SJA1000 Send
- Softing CAN-AC2-PCI with SJA1000 Receive

It also includes a FIFO Mode group, which is discussed in “FIFO Mode” on page 6-2.

CAN-AC2-104 with SJA1000 Controller

The CAN-AC2-104 driver blocks support the Softing CAN-AC2-104 (PC/104) board. The Philips SJA1000 chip is used as the CAN controller in this configuration and supports both standard and extended identifier ranges in parallel. The driver block set for this board is found in the Simulink Real-Time I/O block library in the group CAN/Softing.

The CAN-AC2-104 SJA 1000 block group contains the CAN blocks:

- Softing CAN-AC2-104 with SJA1000 Setup
- Softing CAN-AC2-104 with SJA1000 Send
- Softing CAN-AC2-104 with SJA1000 Receive

It also includes a FIFO Mode group, which is discussed in “FIFO Mode” on page 6-2.

Model Execution Driven by CAN Messages

In certain applications, the real-time application execution can be paced by incoming CAN messages. The standard behavior of the Simulink Real-Time kernel is to drive the real-time application in time monotonic fashion using a time interrupt. However, the driving interrupt can be replaced by other interrupts. Because the three supported CAN boards support firing an interrupt upon reception of a specific CAN message, you can replace the timer interrupt line in the kernel by the interrupt line assigned to a CAN board. You can then drive the real-time application by sending CAN messages, interpreting them in the CAN Receive blocks, and firing an interrupt in response.

To set this up, do the following:

- 1 Replace the timer interrupt line in the kernel setup with the interrupt line of the board.
- 2 Set up the CAN Setup and CAN Receive blocks.

Both steps are slightly different for each of the supported CAN boards.

In this section...
“CAN-AC2-PCI” on page 4-8
“CAN-AC2-104 (PC/104)” on page 4-9

CAN-AC2-PCI

The CAN-AC2 is a PCI board, and the interrupt line is automatically assigned by the PCI BIOS during the initialization of the target system. At the model level, open the **Simulation > Model Configuration Parameters** dialog box. At the **Simulink Real-Time Options** node, set **Real-time interrupt source** Auto (PCI only). This option enables the Simulink Real-Time software to automatically determine the IRQ that the BIOS assigned to the board and use it. Alternatively, use the Simulink Real-Time function `SimulinkRealTime.target.getPCIInfo` at the command prompt to query the target system for installed PCI devices and the assigned resources. Write down the interrupt line number assigned to the CAN-AC2-PCI board.

- 1 In the Simulink Editor, select **Simulation > Model Configuration Parameters**.
The Configuration Parameters dialog box is displayed.
- 2 Select node **Code Generation**.

- 3 In the **Target selection** section, set the **System target file** box to `slrt.tlc`.
- 4 Select the **Simulink Real-Time Options** node.
- 5 In the **Real-time interrupt source** box, select the interrupt line number that you retrieved with the `SimulinkRealTime.target.getPCIInfo` command.

Alternatively, select **Auto (PCI only)** to enable the Simulink Real-Time software to automatically determine the IRQ that the BIOS assigned to the board and use it.

- 6 In the **I/O board generating the interrupt** field, select `Softing_CAN-AC2-PCI`.
- 7 Click **OK** and save the model.
- 8 Open the dialog box of the **CAN Receive** block in the model that defines the CAN message (identifier) to be used to fire the interrupt. Select the **Generate interrupts** check box. Selecting this box declares that the CAN messages defined through their identifiers in this **Receive** block instance are messages that fire an interrupt. In other words, it is not possible to define a single CAN message within the set of defined identifiers to be the only one to fire an interrupt. In most cases only the reception of one specific message is used to drive the application execution. Therefore use at least two instances of the **Receive** block: one to receive the CAN message that drives the execution (**Generate interrupts** selected) and the other for the remaining normal CAN messages to be received (**Generate interrupts** cleared).

CAN-AC2-104 (PC/104)

The CAN-AC2-104 is an ISA board (PC/104), and the interrupt line is set by means of a software setting within the **CAN Setup** block. Note a free interrupt line that is not used by any other device in the Simulink Real-Time system (for example by the Ethernet card).

- 1 In the Simulink Editor, select **Simulation > Model Configuration Parameters**.
The Configuration Parameters dialog box is displayed.
- 2 Select node **Code Generation**.
- 3 In the **Target selection** section, set the **System target file** box to `slrt.tlc`.
- 4 Select the **Simulink Real-Time Options** node.
- 5 In the **Real-time interrupt source** box, select the free interrupt line number that you chose.
- 6 In the **I/O board generating the interrupt** box, select `Softing_CAN-AC2-104`.
- 7 Click **OK** and save the model.

- 8 In the model open the dialog box of the **CAN Setup** block for the CAN-AC2-104 board. Select the chosen interrupt line in the **Interrupt Line** pop-up menu and close the dialog box. Open the dialog box of the **CAN Receive** block in the model that defines the CAN message (identifier) to be used to fire the interrupt. Select the **Generate interrupts** check box. Selecting this box declares that the CAN messages defined through their identifiers in this **Receive** block instance are messages that fire an interrupt. In other words, it is not possible to define a single CAN message within the set of defined identifiers to be the only one to fire an interrupt. In most cases only the reception of one specific message is used to drive the application execution. Therefore use at least two instances of the **Receive** block. One to receive the CAN message that drives the execution (**Generate interrupts** selected) and the other for the remaining normal CAN messages to be received (**Generate interrupts** cleared).

After you complete these two steps, you are ready to build the model. After the downloading has succeeded and the real-time application execution has been started, the execution is now driven by the selected CAN messages. The execution time information displayed on the target display is now directly dependent on the reception of the corresponding message. If no message is received, the time does not advance. The corresponding CAN message on the other CAN node should only be generated if the Simulink Real-Time application is running, otherwise unexpected interrupt messages might be displayed on the target display.

Initialization and Termination CAN Messages

The CAN Setup driver blocks for the supported CAN boards allow the definition of CAN messages to be sent during initialization and termination of the real-time application (once at the beginning of each application run and once before an application run is stopped). The main purpose for sending these messages is to initialize or terminate other CAN nodes on the network. This is the case, for example, for CANopen or DeviceNet nodes. Even if those CAN application layers are not directly supported, communication with those nodes can usually be done over standard CAN messages as long as the nodes have been initialized. The initialization and termination fields of the Setup blocks are intended for this purpose.

You define the initialization and termination CAN messages using MATLAB struct arrays with CAN specific field names. This is the same concept as used for the RS-232 and general counter driver blocks found in the Simulink Real-Time I/O library. Refer to those driver blocks and their help for additional information about this basic concept.

The CAN Setup block-specific field names are the following:

- **Port** — Selects the CAN port over which the message is sent. Valid values are either 1 or 2 (double).
- **Type** — Defines whether the message to be sent is of type standard or extended. Valid values are either 'Standard' or 'Extended' (strings).
- **Identifier** — Defines the identifier of the message. The value (scalar) itself must be in the corresponding identifier range (standard or extended).
- **Data** — Defines the data frame to be sent out along with the CAN message. The length of the row vector defines the data frame size.
 - If the CAN message data type is a CAN_MESSAGE data type, the value of the frame size vector must match the **Length** parameter of the connected CAN Pack block.
 - If the CAN message data type is a double, this field defines the data frame to be sent out along with the CAN message. The value must be a row vector of type double with a maximum length of 8. Each element of the vector defines 1 byte. In this case, the first element defines the data for byte 0 and the eighth element the data for byte 7. Each element can have a value between 0 and 255 (decimal).
- **Pause** — Defines the amount of time in seconds the Setup block waits after this message has been sent and before the next message defined in the struct array is parsed and sent. Valid values are between 0 and 0.05 seconds. Some CAN nodes

need some time to settle before they can accept the next message, especially when the message just received puts the node in a new operational mode. Use this field to specify those idle times.

CAN Data Frames

CAN data frames have a maximum size of 8 bytes (64 bits). The CAN driver blocks in the Simulink Real-Time I/O block library use Simulink signals of data type `CAN_MESSAGE` or `double` to propagate data frames as an entity. In most applications, the data frame content does not consist of 64-bit floating point values; instead they are constructed from one or more smaller data type entities such as signed and unsigned integers of various sizes.

To simplify the construction and extraction of data frames for the user, the Simulink Real-Time I/O library contains two utility blocks (found in subgroup `CAN/Utilities`) that allow bit-packing (construction) and bit-unpacking (extraction) of data frames in a very flexible way.

- The `CAN Bit-Packing` and `CAN Bit-Unpacking` blocks work with data frames using double data types. They provide support for legacy models.
- To construct and extract `CAN_MESSAGE` data types, use the `CAN Pack` and `CAN Unpack` blocks.

Tip

- To prepare a remote frame, use the `CAN Pack` block with the **Remote frame** check box selected. To request the current value, send the remote frame to the responding subsystem.
 - To process a remote frame, use the `CAN Unpack` block with the **Output remote** check box selected to enable the Remote port. When the Remote port becomes `true`, send the current value to the requesting subsystem.
-

The main purpose of the two blocks is to be used in conjunction with `CAN Send` and `Receive` driver blocks for double data type. You can use them for other types of double type data manipulation. Their functionality is independent of the CAN driver blocks or CAN library.

Timeouts When Receiving CAN Messages

The model in this topic supports the `CAN_MESSAGE` data type.

The **Receive** blocks for the supported CAN boards allow you to output the timestamp at which the latest corresponding CAN message was received. This information can be used to detect whether another CAN node is still active and therefore is sending CAN messages or is not active and special action must be taken. Assume that a CAN message is expected from another CAN node every 2 milliseconds. If a new message is not received within 10 milliseconds, the other CAN node is considered faulty, and the Simulink real-time application must proceed accordingly.

The CAN blockset in the Simulink Real-Time I/O block library provides a utility block called **CAN Timeout Detection**. This is a graphical subsystem that uses the timestamp information to calculate the timeout condition.

To use this block:

- 1 Select the **Output timestamp** check box of a **CAN Unpack** block.
- 2 Connect the Timestamp output port to the input port of a **CAN Timeout Detection** block.
- 3 Connect the output port of the **CAN Timeout Detection** block to a sink, such as a real-time **Scope** block.
- 4 Set the **Timeout** value to the required value, such as 0.01 s.

Applying these steps to the “CAN I/O - Simple Use Case” results in the model shown in the figure.

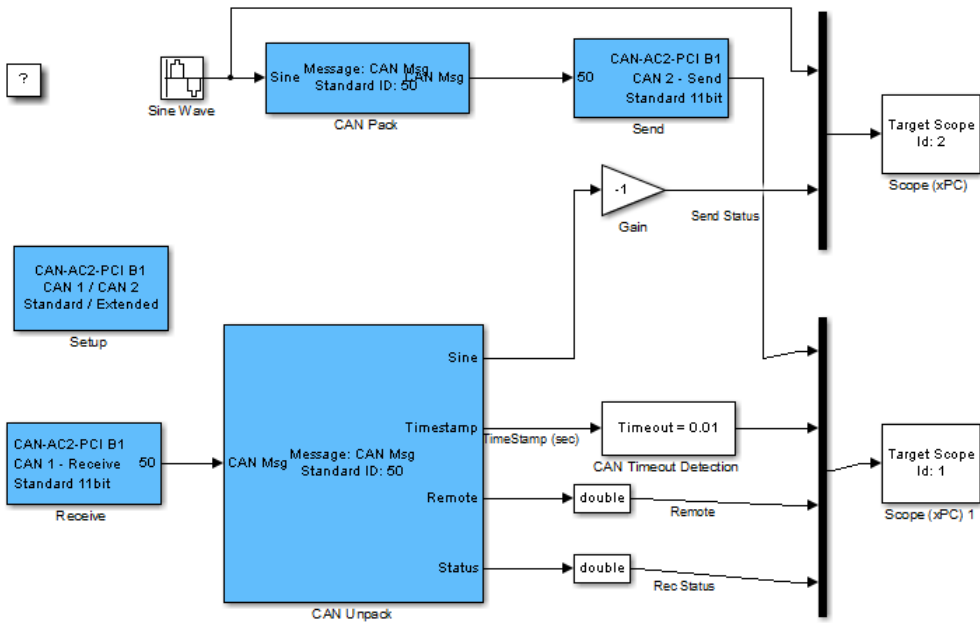

See Also
[ex_slrt_canpcis_timeout](#)

CAN I/O Blocks

Softing CAN-AC2-PCI with SJA1000 Setup

Softing CAN-AC2-PCI with SJA1000 Setup block

Library

Simulink Real-Time Library for CAN

Description

The **Setup** block defines general settings of the installed CAN boards. The CAN driver blocks for this board support up to 16 boards for each target system, making up to 32 CAN ports available. For each board in the target system, you must use exactly one **Setup** driver block.

Block Parameters

Board

Defines the board being accessed by this driver block instance. If multiple boards are present in the target computer, you can use the board number (1...16) to differentiate the boards. The physical board referenced by the board number depends on the **PCI Slot** parameter. If just one board is present in the target system, select board number 1.

CAN 1 - physical bus

Defines the physical CAN bus type of CAN port 1. In the board's standard configuration, only high-speed CAN is supported. By extending the board with low-speed CAN piggyback modules, you can also select low-speed CAN as the physical bus. Do not change this value to low-speed if the module is not present for the corresponding CAN port. If the module is present (see the Softing user manual on how to install the modules), you can select between high-speed and low-speed CAN here.

CAN 1- baud rate

Defines the most common baud rates for CAN port 1. If your model requires a special baud rate, select the value **User defined**. In this case, you use the **CAN 1 - user**

defined baud rate parameter to provide the four values for the timing information. The vector elements have the following meanings:

```
[ Prescaler, Synchronization-Jump-Width, Time-Segment-1,  
Time-Segment-2 ]
```

For more information about these values, see the Softing user manual for this board.

CAN 1 - user defined baud rate

See **CAN 1- baud rate**.

CAN 2 - physical bus

Defines the physical CAN bus type of CAN port 2. In the board's standard configuration, only high-speed CAN is supported. By extending the board with low-speed CAN piggyback modules, you can also select low-speed CAN as the physical bus. Do not set this value should to low-speed if the module is not present for the corresponding CAN port. If the module is present (see the Softing user manual on how to install the modules), you can select between high-speed and low-speed CAN here.

CAN 2 - baud rate

Defines the most common baud rates for CAN port 2. If your model requires a special baud rate, select the value **User defined**. In this case, you can use the **CAN 2 - user defined baud rate** parameter to provide the four values for the timing information. The vector elements have the following meanings:

```
[ Prescaler, Synchronization-Jump-Width, Time-Segment-1,  
Time-Segment-2 ]
```

For more information about these values, see the Softing user manual for this board.

CAN 2 - user defined baud rate

See **CAN 2 - baud rate**.

Initialization command structure and Termination

Defines CAN messages sent during initialization and termination of the **Setup** block.

Termination

Defines CAN messages sent during termination of the **Setup** block.

Show bus-off status output

Select this check box to enable the bus-off status output port. The output signal can be 1 (bus-off state); otherwise, it is 0. If the bus-off status persists, the block optionally initiates recovery, depending on the setting of **Bus-off recovery**.

Clear this check box to disable the output port.

Bus-off recovery

Use this parameter to specify how the model is to perform bus-off recovery for the CAN network.

From the list, select:

- **Off**

Does not perform bus-off recovery.

- **Auto**

Upon detection, the model waits 1 second to see if the bus-off state persists. After 1 second, bus-off recovery occurs.

- **Manual Trigger Input**

Enables you to input a signal when you want bus-off recovery to occur. Selecting this option creates an input port for the **Setup** block.

PCI slot (-1:autosearch)

If only one board of this type is in the target computer, enter - 1 to locate the board.

If two or more boards of this type are in the target computer, enter the bus number and the PCI slot number of the board associated with this driver block. Use the format **[BusNumber, SlotNumber]**.

To determine the bus number and the PCI slot number, type:

```
tg = slrt;  
getPCIInfo(tg, 'installed')
```

The board allows you to terminate each of the two CAN ports separately by means of DIP switches at the rear panel. Refer to the Softing user manual on how to set the DIP switches. Both CAN ports must be terminated when you use the loopback model provided to test the board and drivers.

External Websites

- www.can-cia.org
- company.softing.com/en

Softing CAN-AC2-PCI with SJA1000 Send

Softing CAN-AC2-PCI with SJA1000 Send block

Library

Simulink Real-Time Library for CAN

Description

The **Send** driver block transmits data to a CAN network from within a block model.

To use `CAN_MESSAGE` data types to transmit messages, first use the **CAN Pack** block to create CAN messages for transmission.

- Do not mix message data types with each **Send** block. Either transmit only `CAN_MESSAGE` data types, or transmit only 8 bytes in double data types.
- To prepare a remote frame, use the **CAN Pack** block with the **Remote frame** check box selected. To request the current value, send the remote frame to the responding subsystem.

Block Parameters

Board

Defines the board used to send out the CAN messages defined by this block instance. For more information about the meaning of the board number see the **Setup** driver block described above. If just one board is present in the target system, select board number 1.

CAN port

Selects the CAN port to which the CAN message is sent.

CAN identifier range

Selects the identifier range of the CAN messages sent by this block instance. If an application makes use of mixed standard and extended identifier ranges, you must use at least two instances of this block, each defining the corresponding identifier range.

If the CAN message data type is a `CAN_MESSAGE` data type, this range must match the range packed in the message parameter (for example, the message from the `CAN Pack` block).

Identifiers

Defines the identifiers of the CAN messages sent by this block. It must be a row vector in which the elements define a set of either standard or extended identifiers. Each element must be in the range between 0 and 2047 for standard identifiers or 0 and $2^{29} - 1$ for extended identifiers. The number of identifiers for each CAN port in a model per physical CAN board cannot exceed 200 (limitation of the firmware's dynamic object mode). The number of elements defined here also defines the number of input ports of the block. The block icon displays the selected identifier at each input port.

- If the CAN message data type is `CAN_MESSAGE`, connect each input port to one `CAN Pack` block. Verify that the **Identifier** parameter for each `CAN Pack` block matches the send block input port. Do not connect a vector of messages to an input port. Each input port number also indicates sending priority, with the lowest number having the highest priority.

If the CAN message data type is a `CAN_MESSAGE` data type, these identifiers must match those packed in the message parameter (for example, the message from the `CAN Pack` block).

- If the CAN message data type is not `CAN_MESSAGE` data type, each input port accepts the data frame to be sent along with the CAN message. The signal entering each input port must be a scalar of type double representing the maximum size of 8 bytes of a CAN message data frame.

Data frame sizes

Defines the data frame size, in bytes, for each CAN message represented by an identifier in the **Identifiers** list. It must be a row vector in which the elements define a set of data frame sizes. Each element must be in the range between 1 and 8. If the data frame sizes for the identifiers must be the same, you can provide the size as a scalar, and scalar expansion applies. If the sizes are different for at least two identifiers, you must provide one element for each identifier. Therefore the length of the two vectors must be the same.

If the CAN message data type is a `CAN_MESSAGE` data type, these identifiers must match those packed in the message parameter (for example, the message from the `CAN Pack` block).

Show status output ports

Enables status output ports for each CAN message represented by an identifier in the **Identifiers** list. If the check box is selected, the block shows as many output ports as input ports. The data type of each output port is a double, given in the table. Refer to the Softing manual for more information. The function return codes are:

Code	Description
0	Function executed without detecting an error.
-1	Request overrun.
-2	CAN_MESSAGE data type only. Input port message from CAN Pack block has incorrect Identifiers or CAN identifier range value. This is not a Softing standard.
-3	CAN_MESSAGE data type only. Input port message from CAN Pack block has incorrect Data frame sizes value. This is not a Softing standard.
-4	Timed out firmware communication.
-99	Board not initialized.

Sample time

Defines the sample time at which the **Send** block is executed during a real-time application run.

You can use as many instances of the **Send** block in the model as required. For example, by using two instances of the block, you can send CAN messages at different sample times. Or you can use multiple instances to structure your model more efficiently.

External Websites

- www.can-cia.org
- company.softing.com/en

Softing CAN-AC2-PCI with SJA1000 Receive

Softing CAN-AC2-PCI with SJA1000 Receive block

Library

Simulink Real-Time Library for CAN

Description

The **Receive** driver block retrieves data from a CAN network to be used within a block model. You can use as many instances of the **Receive** block in the model as required.

To use `CAN_MESSAGE` data types to transmit messages, use the **CAN Unpack** block to unpack individual signals from the received CAN messages.

- Do not mix message data types in a block. Each block can receive only `CAN_MESSAGE` data types, or receive only 8 bytes in double data types.
- To process a remote frame, use the **CAN Unpack** block with the **Output remote** check box selected to enable the Remote port. When the Remote port becomes `true`, send the current value to the requesting subsystem.

Block Parameters

Board

Defines the board the CAN messages defined by this block instance are retrieved from. For more information about the meaning of the board number, see the **Setup** driver block described above. If just one board is present in the target system, select board number 1.

CAN port

Selects the CAN port from which the CAN messages are retrieved.

CAN identifier range

Selects the identifier range of the CAN messages retrieved by this block instance. If an application makes use of mixed standard and extended identifier ranges,

you must use at least two instances of this block, each defining the corresponding identifier range.

If the CAN message data type is a CAN_MESSAGE data type, this range must match the **Identifier type** parameter of the connected CAN Unpack block.

Identifiers

Defines the identifiers of the CAN messages retrieved by this block. It must be a row vector in which the elements define a set of either standard or extended identifiers. Each element must be in the range between 0 and 2047 for standard identifiers or 0 and $2^{29} - 1$ for extended identifiers. The number of identifiers for each CAN port in a model per physical CAN board cannot exceed 200 (limitation of the firmware's dynamic object mode). The number of elements defined here also defines the number of output ports of the block. The block icon displays the selected identifier at each output port.

Message lengths

Defines the message length, in bytes, for each CAN message represented by an identifier in the **Identifiers** list. It must be a row vector in which the elements define a set of message lengths. Each element must be in the range between 0 and 8. If the message length for the identifiers must be the same, you can provide the length as a scalar, and scalar expansion applies. If the lengths are different for at least two identifiers, you must provide one length element for each identifier. Therefore the dimensions of the two vectors must be the same.

Output port options

If the CAN message data type is CAN_MESSAGE, connect each output port to one CAN Unpack block. Verify that the **Identifier** parameter for each CAN Unpack block matches the Receive block output port.

If the CAN message data type is not CAN_MESSAGE data type, each output port outputs the data frame being retrieved along with the CAN message. The signal leaving each output port is a scalar of type double representing the maximum size of 8 bytes of a CAN message data frame.

From the list, select:

Data

Output vector of one double with just data.

Data - Status

Output vector of two doubles. First element of the vector contains the data, the second element contains the status.

Data - Timestamp

Output vector of two doubles. First element of the vector contains the data, the second element contains the timestamp.

Data - Status - Timestamp

Output vector of three doubles. First element of the vector contains the data, the second element contains the status, the third element contains the timestamp.

CAN_MESSAGE data type

One CAN_MESSAGE. You can extract the data, status, and timestamp from this message using a CAN Unpack block.

Refer to the Softing manual for more information. The function return codes are:

Code	Description
0	No new data received.
1	Data frame received.
2	Remote frame received.
-1	Receive data frame overrun.
-2	Receive remote frame overrun.
-3	Object not active.
-7	Timed out firmware communication
-99	Board not initialized.

Generate interrupts

Defines whether the CAN messages defined in this instance of the block will initiate an interrupt from the CAN board each time they are received. If selected, you can use CAN messages to control real-time application execution.

Sample time

Defines the sample time at which the Send block is executed during a real-time application run.

You can use as many instances of the Receive block in the model as required. For example, by using two instances of the block, you can check for CAN messages at

different sample times. Or you can use multiple instances to structure your model more efficiently.

External Websites

- www.can-cia.org
- company.softing.com/en

Softing CAN-AC2-104 with SJA1000 Setup

Softing CAN-AC2-104 with SJA1000 Setup block

Library

Simulink Real-Time Library for CAN

Description

The **Setup** block defines general settings of the stacked CAN boards. The CAN driver blocks for this board support up to three boards for each target system, making up to six CAN ports available. For each board in the target system, you must use exactly one **Setup** driver block.

Block Parameters

Board

Defines the board being accessed by this driver block instance. If multiple boards are present in the target computer, you can use the board number (1...3) to differentiate the boards. The physical board referenced by the board number depends on the **PCI Slot** parameter. If just one board is present in the target system, select board number 1. The physical board referenced by the board number depends on the **I/O base address** parameter.

CAN 1 - baud rate

Defines the most common baud rates for CAN port 1. If your model requires a special baud rate, select the value **User defined**. In this case, use the **CAN 1 - user defined baud rate** parameter to provide the four values for the timing information. The vector elements have the following meanings:

```
[ Prescaler, Synchronization-Jump-Width, Time-Segment-1,  
Time-Segment-2 ]
```

For more information about these values, see the Softing user manual for this board.

CAN 1 - user defined baud rate

See **CAN 1- baud rate**.

CAN 2 - baud rate

Defines the most common baud rates for CAN port 2. If your model requires a special baud rate, select the value **User defined**. In this case, use the **CAN 2 - user defined baud rate** parameter to provide the four values for the timing information. The vector elements have the following meanings:

```
[ Prescaler, Synchronization-Jump-Width, Time-Segment-1,  
Time-Segment-2 ]
```

For more information about these values, see the Softing user manual for this board.

CAN 2 - user defined baud rate

See **CAN 2 - baud rate**.

Initialization command structure and Termination

Define CAN messages sent during initialization and termination of the **Setup** block.

Show bus-off status output

Select this check box to enable the bus-off status output port. The output signal can be 1 (bus-off state); otherwise, it is 0. If the bus-off status persists, the block optionally initiates recovery, depending on the setting of **Bus-off recovery**.

Clear this check box to disable the output port.

Bus-off recovery

Use this parameter to specify how the model is to perform bus-off recovery for the CAN network.

From the list, select:

- **Off**

Does not perform bus-off recovery.

- **Auto**

Upon detection, the model waits 1 second to see if the bus-off state persists. After 1 second, bus-off recovery occurs.

- **Manual Trigger Input**

Enables you to input a signal when you want bus-off recovery to occur. Selecting this option creates an input port for the **Setup** block.

Termination

Define CAN messages sent during termination of the **Setup** block.

I/O base address

Defines the I/O base address of the board to be accessed by this block instance. The I/O base address is given by the DIP switch setting on the board itself. The I/O address range is 4 bytes of I/O address space. It is mainly used to transfer the memory base address the board should use. See the Softing user manual for this board to set the I/O base address. The I/O base address entered in this control must correspond with the DIP switch setting on the board. If more than one board is present in the target system, a different I/O base address must be entered for each board. In this case the I/O base address itself defines which board is referenced by which board number.

Memory base address

Defines the memory base address of the board to be accessed by this block instance. The memory base address is a software setting only (the board does not have a corresponding DIP switch). The memory address range is 4 KB.

If more than one board is present in the target system, a different memory base address must be entered for each board. You must make sure that the defined address ranges do not overlap.

The Softing CAN-AC2-104 driver can address a memory map in the memory range C8000 - F7FFF. However, the Simulink Real-Time software only reserves memory-mapped space in the address range C0000 - DBFFF. Therefore, you must address the Softing CAN-AC2-104 in the range

C8000 - DBFFF

The board allows you to terminate each of the two CAN ports separately by means of jumpers found on the board. Refer to the board user manual for how the DIP switches must be set. Both CAN ports must be terminated when you use the loopback model provided to test the board and drivers.

Interrupt line

Selects an interrupt line from the list.

External Websites

- www.can-cia.org
- company.softing.com/en

Softing CAN-AC2-104 with SJA1000 Send

Softing CAN-AC2-104 with SJA1000 Send block

Library

Simulink Real-Time Library for CAN

Description

The **Send** driver block transmits data to a CAN network from within a block model. You can define up to 200 send objects for standard and extended identifiers for each CAN channel.

To use `CAN_MESSAGE` data types to transmit messages, first use the **CAN Pack** block to create CAN messages for transmission.

- Do not mix message data types with each **Send** block. Either transmit only `CAN_MESSAGE` data types, or transmit only 8 bytes in double data types.
- To prepare a remote frame, use the **CAN Pack** block with the **Remote frame** check box selected. To request the current value, send the remote frame to the responding subsystem.

Block Parameters

Board

Defines the board to use to send the CAN messages defined by this block instance. For more information about the meaning of the board number, see the **Setup** driver block described above. If just one board is present in the target system, select board number 1.

CAN Port

Selects the CAN port to send the CAN message.

CAN identifier range

Selects the identifier range of the CAN messages sent by this block instance. If an application makes use of mixed standard and extended identifier ranges, you must

use at least two instances of this block, each defining the corresponding identifier range.

If the CAN message data type is a `CAN_MESSAGE` data type, this range must match the range packed in the message parameter (for example, the message from the `CAN Pack` block).

Identifiers

Defines the identifiers of the CAN messages sent by this block. It must be a row vector in which the elements define a set of either standard or extended identifiers. Each element must be in the range between 0 and 2047 for standard identifiers or 0 and $2^{29} - 1$ for extended identifiers. The number of identifiers for each CAN port in a model per physical CAN board cannot exceed 200 (limitation of the firmware's dynamic object mode). The number of elements defined here also define the number of input ports of the block. The block icon displays the selected identifier at each input port.

- If the CAN message data type is `CAN_MESSAGE`, connect each input port to one `CAN Pack` block. Verify that the **Identifier** parameter for each `CAN Pack` block matches the `Send` block input port. Do not connect a vector of messages to an input port. Each input port number also indicates sending priority, with the lowest number having the highest priority.

If the CAN message data type is a `CAN_MESSAGE` data type, these identifiers must match those packed in the message parameter (for example, the message from the `CAN Pack` block).

- If the CAN message data type is not `CAN_MESSAGE` data type, each input port accepts the data frame to be sent along with the CAN message. The signal entering each input port must be a scalar of type double representing the maximum size of 8 bytes of a CAN message data frame.

Data frame sizes

Defines the data frame size, in bytes, for each CAN message represented by an identifier in the **Identifiers** list. It must be a row vector in which the elements define a set of data frame sizes. Each element must be in the range between 1 and 8. If the data frame sizes for the identifiers must be the same, you can provide the size as a scalar, and scalar expansion applies. If the sizes are different for at least two identifiers, you must provide one element for each identifier. Therefore the length of the two vectors must be the same.

If the CAN message data type is a CAN_MESSAGE data type, these identifiers must match those packed in the message parameter (for example, the message from the CAN Pack block).

Show status output ports

Enables status output ports for each CAN message represented by an identifier in the **Identifiers** list. If the check box is selected, the block shows as many output ports as input ports. The data type of each output port is a double, given in the table. Refer to the Softing manual for more information. The function return codes are:

Code	Description
0	Function executed without detecting an error.
-3	CAN_MESSAGE data type only. Input port message from CAN Pack block has incorrect Data frame sizes value.
-1	Request overrun.
-2	CAN_MESSAGE data type only. Input port message from CAN Pack block has incorrect Identifiers or CAN identifier range value. This is not a Softing standard.
-3	CAN_MESSAGE data type only. Input port message from CAN Pack block has incorrect Data frame sizes value. This is not a Softing standard.
-4	Timed out firmware communication.
-99	Board not initialized.

Sample time

Defines the sample time at which the **Send** block is executed during a real-time application run.

You can use as many instances of the **Send** block in the model as required. For example, by using two instances of the block, you can define different sample times at which CAN messages are sent out. Or you can use multiple instances to structure your model more efficiently.

External Websites

- www.can-cia.org

- company.softing.com/en

Softing CAN-AC2-104 with SJA1000 Receive

Softing CAN-AC2-104 with SJA1000 Receive block

Library

Simulink Real-Time Library for CAN

Description

The **Receive** driver block retrieves data from a CAN network to be used within a block model. You can use as many instances of the **Receive** block in the model as required.

To use `CAN_MESSAGE` data types to transmit messages, use the **CAN Unpack** block to unpack individual signals from the received CAN messages.

- Do not mix message data types in a block. Each block can receive only `CAN_MESSAGE` data types, or receive only 8 bytes in double data types.
- To process a remote frame, use the **CAN Unpack** block with the **Output remote** check box selected to enable the Remote port. When the Remote port becomes `true`, send the current value to the requesting subsystem.

Block Parameters

Board

Defines the board from which the CAN messages defined by this block instance are to be retrieved. For more information about the meaning of the board number, see the **Setup** driver block. If just one board is present in the target system, select board number 1.

CAN Port

Selects the CAN port from which to retrieve the CAN message.

CAN identifier range

Selects the identifier range of the CAN messages retrieved by this block instance. If an application makes use of mixed standard and extended identifier ranges, at least

two instances of this block must be used, each defining the corresponding identifier range.

If the CAN message data type is a CAN_MESSAGE data type, this range must match the **Identifier type** parameter of the connected CAN Unpack block.

Identifiers

Specifies the identifiers of the CAN messages retrieved by this block. It must be a row vector where the elements define a set of either standard or extended identifiers. Each element must be in the range between 0 and 2047 for standard identifiers, or 0 and $2^{29} - 1$ for extended identifiers. The number of identifiers for each CAN port in a model per physical CAN board cannot exceed 200. The number of elements defined here defines the number of output ports of the block. The block icon displays the selected identifier at each output port.

Message lengths

Defines the message length, in bytes, for each CAN message represented by an identifier in the **Identifiers** list. It must be a row vector in which the elements define a set of message lengths. Each element must be in the range between 0 and 8. If the message length for identifiers must be the same, you can provide the length as a scalar, and scalar expansion applies. If the lengths are different for at least two identifiers, you must provide one length element for each identifier. Therefore the dimensions of the two vectors must be the same.

Output port options

If the CAN message data type is CAN_MESSAGE, connect each output port to one CAN Unpack block. Verify that the **Identifier** parameter for each CAN Unpack block matches the receive block output port.

If the CAN message data type is not CAN_MESSAGE data type, each output port outputs the data frame being retrieved along with the CAN message. The signal leaving each output port is a scalar of type double representing the maximum size of 8 bytes of a CAN message data frame.

From the list, select:

Data

Output vector of one double with just data.

Data - Status

Output vector of two doubles. First element of the vector contains the data, the second element contains the status.

Data - Timestamp

Output vector of two doubles. First element of the vector contains the data, the second element contains the timestamp.

Data - Status - Timestamp

Output vector of three doubles. First element of the vector contains the data, the second element contains the status, the third element contains the timestamp.

CAN_MESSAGE data type

One CAN_MESSAGE. You can extract the data, status, and timestamp from this message using a CAN Unpack block.

Refer to the Softing manual for more information. The function return codes are:

Code	Description
0	No new data received.
1	Data frame received.
2	Remote frame received.
-1	Receive data frame overrun.
-2	Receive remote frame overrun.
-3	Object not active.
-7	Timed out firmware communication
-99	Board not initialized.

Generate interrupts

Defines whether the CAN messages defined in this instance of the block initiate an interrupt from the CAN board each time they are received. If selected, you can use CAN messages to control real-time application execution.

Sample time

Defines the sample time at which the Receive block is executed during a real-time application run.

You can use as many instances of the Receive block in the model as required. For example, by using two instances of the block, you can check for different sample times at which CAN messages are retrieved. Or you can use multiple instances to structure your model more efficiently. You can define up to 200 receive objects for standard and extended identifiers for each CAN channel.

External Websites

- www.can-cia.org
- company.softing.com/en

CAN Bit-Packing

CAN Bit-Packing block

Library

Simulink Real-Time Library for CAN

Description

This block is for message data of type double. This block constructs CAN data frames, and its output port is ordinarily connected to an input port of a **CAN Send** driver block. The block has one output port of data type double (a scalar), which represents the data frame entity constructed by the signals entering the block at its input ports. The number of input ports depends on the setting in the block dialog box.

Do not use this block to construct `CAN_MESSAGE` data types or to prepare a remote frame. Use the **CAN Pack** block.

Block Parameters

Bit Patterns

Specify bit patterns. The data type entered in the control must be a MATLAB cell array vector. The number of elements in the cell array define the number of input ports shown by this block instance. The cell array elements must be of type double array and define the position of each bit of the incoming value (data typed input port) in the outgoing double value (data frame).

From a data type perspective (input ports), the block behaves like a Simulink **Sink** block, and therefore the data types of the input ports are inherited from the driving blocks.

The sample time of the block is also inherited from the driving blocks. Therefore you do not need an explicit sample time in the block dialog box.

Example

The example in this topic describes the use of the Softing CAN blocks with standard double data types for message storage. For an alternative and easier way to pack CAN_MESSAGE data types, use the **CAN Pack** block.

The functionality of the block is best explained by means of an example.

Assume that a node on the CAN network needs to receive a CAN message with identifier 156 having the following data frame content. The data frame must be 6 bytes long.

Byte 0	Function class of type <code>uint8</code>
Byte 1	Function subclass of type <code>uint8</code> with reversed bit order
Byte 2	Reserved, all bits must be 1
Byte 3	Bit 0 must be 0, Bit 1 must be a boolean (flag), bits 2 to 7 must be bit 2 to 7 of an incoming <code>int8</code> value (control)
Byte 4 and 5	Value of type <code>int16</code>

The bit pattern cell array, which bit-packs the data frame according to the above specification, can look as follows:

```
{ [0:7] , [15:-1:8] , [16:23] , [25] , [-1,-1,26:31] , [32:47] }
```

And the Simulink model simulating the required behavior would be as shown.

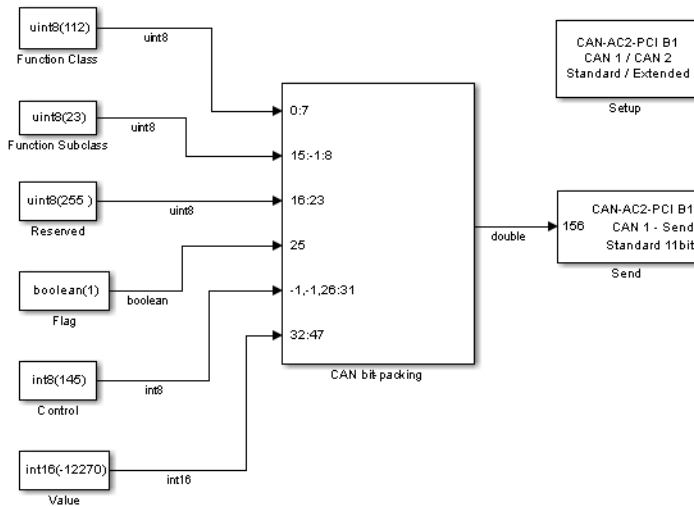

- The function class is of type uint8, which has an example value of 112. This value becomes byte 0 (bits 0 to 7) of the data frame. Therefore the first bit (element 1 of double array [0:7]) gets bit 0 of the data frame, the second bit 1, and so on. It is easiest to define this mapping by the MATLAB colon operator (:).
- The function subclass is of type uint8, which has an example value of 23. This value becomes byte 1 (bits 8:15) of the data frame but in reversed bit order. Therefore the first bit (element 1 of double array [15:-1:8]) gets bit 15, the second bit 14, and so on. It is easiest to define this mapping by the MATLAB colon operator (:) and an increment of -1.
- The reserved byte 2 must have all bits set to 1. If a bit position in the outgoing data frame is not referenced by a bit pattern array element, the bit is 0 by default, but you cannot set them to 1 as the default. Therefore a uint8 constant with value 255 must be brought in externally. The constant 255 must get to bit position 16 to 23 (byte 2) of the outgoing data frame.

Because bit 0 of data frame byte 3 (bit 24) must be 0, and 0 is the default bit value if not referenced by a bit pattern array element, you do not need to take an explicit action here.

- The flag is of type boolean, which has an example value of 1. This value must become bit 1 of byte 3 (bit 25) of the data frame. Therefore the single bit (element 1 of double array [25]) must get bit 25 of the data frame.

- The control is of type `int8`, which has an example value of 121. But only bits 2 to 7 must be mapped into the outgoing data frame or, in other words, bits 0 and 1 must be thrown away. Because indexing of incoming values starts with the first bit (bit 0), a special indexing value (-1) must be used to skip bit 0 and 1 of the incoming `int8` value. Bits 2 to 7 are directly mapped to bits 2 to 7 of byte 3 (bits 26 to 31) of the outgoing data frame. This leads to the following bit pattern: [-1,-1,26:31].
- The value is of type `int16`, which has an example value of -12270. This value must become byte 4 and 5 (bits 32 to 47) of the outgoing data frame. Therefore the first bit (element 1 of double array [32:47]) must get bit 32 of the data frame, the second bit 33, and so on. It is easiest to define this mapping by the MATLAB colon operator (:).
- The output of the **CAN Bit-Packing** block consists of a double value representing the packed data types within the first six bytes. The last two bytes are zero. This means that even in the case where less than eight bytes are significant, the CAN data frame is represented by a double value (eight bytes). The value of the constructed floating-point double does not have a particular meaning but you still see it with a numerical display.
- The data frame is then propagated to the **CAN Send** driver block and is sent as part of a CAN message having identifier 156. In the **Send** block's dialog box, the data frame size is 6 bytes, meaning that only the first six bytes of the incoming double value are transmitted as part of the CAN message.

External Websites

- www.can-cia.org
- company.softing.com/en

CAN Bit-Unpacking

CAN Bit-Unpacking block

Library

Simulink Real-Time Library for CAN

Description

This block is for message data of type double. This block extracts CAN data frames, and its input port is normally connected to an output port of a **CAN Receive** driver block. The block has one input port of data type double (a scalar), which represents the data frame entity from which the signals are extracted and leaving the block at its output ports. The number of output ports and the data type of each output port depend on the settings in the block dialog box.

Do not use this block to unpack `CAN_MESSAGE` data types or to process a remote frame. Use the **CAN Unpack** block.

Block Parameters

Bit Patterns

Lets you define the bit patterns in a flexible way. The data type entered in the control must be a MATLAB cell array vector. The number of elements in the cell array define the number of output ports shown by this block instance. The cell array elements must be of type double array and define the position of each bit of the incoming value (data typed output port) in the incoming double value (data frame).

Data Types

From a data type perspective (output ports), the block behaves like a Simulink **Source** block, and therefore the data types of the output ports must be defined in the second control (edit field). The data type entered in that control must be a MATLAB cell array vector of the same length as the bit pattern cell array. The cell array elements must be of type char and define the data type of the corresponding output port. The following values are supported:

`boolean, int8, uint8, int16, uint16, int32, uint32`

The sample time of the block is inherited from the driving block. Therefore you do not need to provide an explicit sample time in the block dialog box.

If you unpack the data frame into a signed type (`int8`, `int16`, or `int32`), the block performs sign extension. For example, if the bit pattern is `[0:4]`, and the data type is `int8`, you are extracting 5 bits into an 8 bit wide signed type. In this case, bits 5, 6, and 7 are the same as bit 4, resulting in sign extension. This functionality enables you to pack and unpack negative numbers without losing precision. In the preceding example, you can pack and unpack numbers in the range `[-16 : 15]` (a fictitious `int5` type).

Example

The example in this topic describes the use of the Softing CAN blocks with standard double data types for message storage. For an alternative and easier way to unpack `CAN_MESSAGE` data types, use the `CAN Unpack` block.

The functionality of the block is easiest explained by means of an example. The same example as used above shows the functionality of the `CAN Bit-Packing` block. But in this case, the data frame is sent by an external CAN node and is received by the real-time application running on a Simulink Real-Time system. Therefore the `CAN Bit-Unpacking` block is used to extract the various data fields from the entire data frame. Because the bit pattern definitions of the packing and unpacking block are symmetric, the bit pattern definition could look exactly the same. You do not need to extract byte 2 (reserved area), because its content is known. The bit pattern edit field can therefore look as follows:

```
{ [0:7] , [15:-1:8] , [25] , [-1,-1,26:31] , [32:47] }
```

and the data type edit field as

```
{ 'uint8' , 'uint8' , 'boolean' , 'int8' , 'int16' }
```

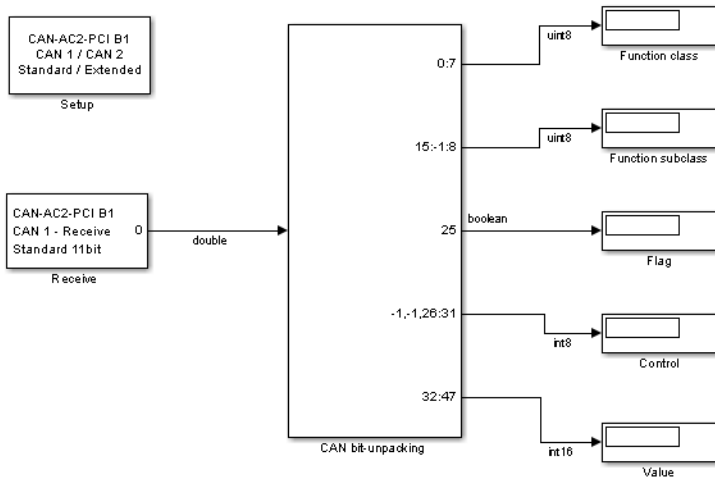

This leads to the following Simulink model.

In many cases it makes sense to test the bit-packing and unpacking operations in a Simulink model (simulation) before building the real-time application. Both blocks work the same way either in the Simulink system or the generated code. By combining the two models shown so far, a third model emerges that can be used to simulate the behavior.

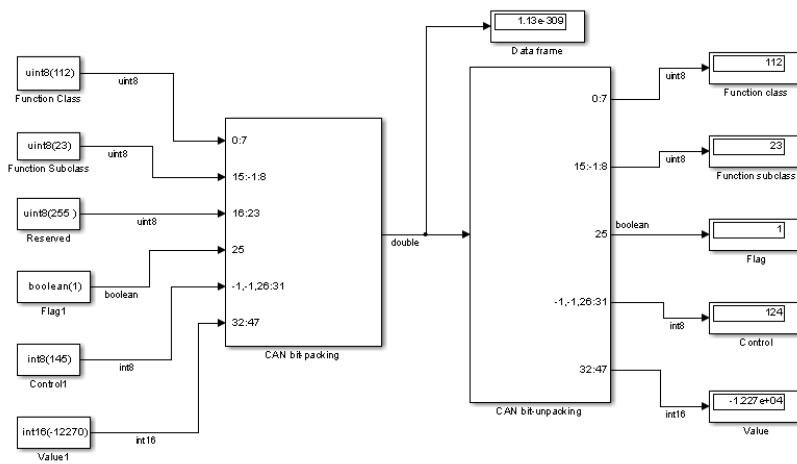

External Websites

- www.can-cia.org
- company.softing.com/en

CAN Timeout Detection

CAN Timeout Detection block

Library

Simulink Real-Time Library for CAN

Description

This block uses the timestamp information to calculate the timeout condition. To use this block, select the **Output timestamp** check box of a **CAN Unpack** block. Then connect the Timestamp output port to the input port of the **CAN Timeout Detection** block.

For an example of this usage, add this block to `xpccanpcis`, a loopback example for the CAN-AC2-PCI board using `CAN_MESSAGE` data types for message storage.

Block Parameters

Timeout

Specify the timeout value, in seconds. The output of the block is:

- 0, if a timeout has not been detected
- 1, if a timeout has been detected

External Websites

- www.can-cia.org
- company.softing.com/en

CAN Pack

Pack individual signals into CAN message

Library

CAN Communication

Embedded Coder[®]/ Embedded Targets/ Host Communication

Description

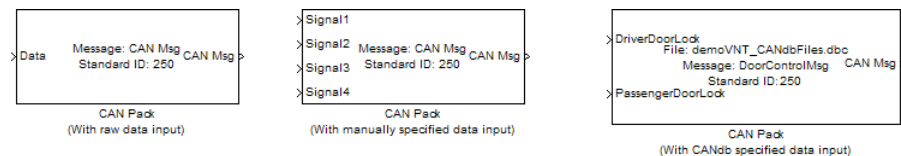

The CAN Pack block loads signal data into a message at specified intervals during the simulation.

Note: To use this block, you also need a license for Simulink software.

CAN Pack block has one input port by default. The number of block inputs is dynamic and depends on the number of signals you specify for the block. For example, if your block has four signals, it has four block inputs.

This block has one output port, CAN Msg. The CAN Pack block takes the specified input parameters and packs the signals into a message.

Other Supported Features

The CAN Pack block supports:

- The use of Simulink Accelerator[™] Rapid Accelerator mode. Using this feature, you can speed up the execution of Simulink models.

- The use of model referencing. Using this feature, your model can include other Simulink models as modular components.
- Code generation using Simulink Coder to deploy models to targets.

Note: Code generation is not supported if your signal information consists of signed or unsigned integers greater than 32-bits long.

For more information on these features, see the Simulink documentation.

Dialog Box

Use the Function Block Parameters dialog box to select your **CAN Pack** block parameters.

Parameters

Data is input as

Select your data signal:

- **raw data:** Input data as a uint8 vector array. If you select this option, you only specify the message fields. all other signal parameter fields are unavailable. This option opens only one input port on your block.
- **manually specified signals:** Allows you to specify data signal definitions. If you select this option, use the **Signals** table to create your signals. The number of block inputs depends on the number of signals you specify.
- **CANdb specified signals:** Allows you to specify a CAN database file that contains message and signal definitions. If you select this option, select a CANdb file. The number of block inputs depends on the number of signals specified in the CANdb file for the selected message.

CANdb file

This option is available if you specify that your data is input via a CANdb file in the **Data is input as** list. Click **Browse** to find the CANdb file on your system. The message list specified in the CANdb file populates the **Message** section of the dialog box. The CANdb file also populates the **Signals** table for the selected message.

Note: File names that contain non-alphanumeric characters such as equal signs, ampersands, and so forth are not valid CAN database file names. You can use periods in your database name. Rename CAN database files with non-alphanumeric characters before you use them.

Message list

This option is available if you specify that your data is input via a CANdb file in the **Data is input as** field and you select a CANdb file in the **CANdb file** field. Select the message to display signal details in the **Signals** table.

Message

Name

Specify a name for your CAN message. The default is **CAN Msg**. This option is available if you choose to input raw data or manually specify signals. This option is unavailable if you choose to use signals from a CANdb file.

Identifier type

Specify whether your CAN message identifier is a **Standard** or an **Extended** type. The default is **Standard**. A standard identifier is an 11-bit identifier and an extended identifier is a 29-bit identifier. This option is available if you choose to input raw data or manually specify signals. For **CANdb specified signals**, the **Identifier type** inherits the type from the database.

Identifier

Specify your CAN message ID. This number must be a positive integer from 0 through 2047 for a standard identifier and from 0 through 536870911 for an extended identifier. You can also specify hexadecimal values using the **hex2dec** function. This option is available if you choose to input raw data or manually specify signals.

Length (bytes)

Specify the length of your CAN message from 0 to 8 bytes. If you are using **CANdb specified signals** for your data input, the CANdb file defines the length of your message. If not, this field defaults to **8**. This option is available if you choose to input raw data or manually specify signals.

Remote frame

Specify the CAN message as a remote frame.

Signals Table

This table appears if you choose to specify signals manually or define signals using a CANdb file.

If you are using a CANdb file, the data in the file populates this table automatically and you cannot edit the fields. To edit signal information, switch to manually specified signals.

If you have selected to specify signals manually, create your signals manually in this table. Each signal you create has the following values:

Name

Specify a descriptive name for your signal. The Simulink block in your model displays this name. The default is `Signal [row number]`.

Start bit

Specify the start bit of the data. The start bit is the least significant bit counted from the start of the message data. The start bit must be an integer from 0 through 63.

Length (bits)

Specify the number of bits the signal occupies in the message. The length must be an integer from 1 through 64.

Byte order

Select either of the following options:

- **LE:** Where the byte order is in little-endian format (Intel[®]). In this format you count bits from the start, which is the least significant bit, to the most significant bit, which has the highest bit index. For example, if you pack one byte of data in little-endian format, with the start bit at 20, the data bit table resembles this figure.

Bit Number		Bit 7	Bit 6	Bit 5	Bit 4	Bit 3	Bit 2	Bit 1	Bit 0
Data Byte Number	Byte 0	7	6	5	4	3	2	1	0
	Byte 1	15	14	13	12	11	10	9	8
	Byte 2	23	22	21	20	19	18	17	16
	Byte 3	31	30	29	28	27	26	25	24
	Byte 4	39	38	37	36	35	34	33	32
	Byte 5	47	46	45	44	43	42	41	40
	Byte 6	55	54	53	52	51	50	49	48
	Byte 7	63	62	61	60	59	58	57	56

Little-Endian Byte Order Counted from the Least Significant Bit to the Highest Address

- BE: Where byte order is in big-endian format (Motorola®). In this format you count bits from the start, which is the least significant bit, to the most significant bit. For example, if you pack one byte of data in big-endian format, with the start bit at 20, the data bit table resembles this figure.

		Bit Number							
		Bit 7	Bit 6	Bit 5	Bit 4	Bit 3	Bit 2	Bit 1	Bit 0
Data Byte Number	Byte 0	7	6	5	4	3	2	1	0
	Byte 1	15	14	13	12	11	10	9	8
	Byte 2	23	22	21	20	19	18	17	16
	Byte 3	31	30	29	28	27	26	25	24
	Byte 4	39	38	37	36	35	34	33	32
	Byte 5	47	46	45	44	43	42	41	40
	Byte 6	55	54	53	52	51	50	49	48
	Byte 7	63	62	61	60	59	58	57	56

The diagram illustrates the bit numbering for a CAN message. The bits are numbered from 0 to 63, with bit 0 being the least significant bit (LSB) and bit 63 being the most significant bit (MSB). The bits are grouped into 8 bytes, with each byte containing 8 bits. The bits are numbered from 7 to 0 for each byte, with bit 7 being the most significant bit of that byte and bit 0 being the least significant bit of that byte. The diagram shows that data is written up to the most significant bit and ends at bit 11, and data begins at the least significant bit and starts at bit 20.

Big-Endian Byte Order Counted from the Least Significant Bit to the Lowest Address

Data type

Specify how the signal interprets the data in the allocated bits. Choose from:

- signed (default)
- unsigned
- single
- double

Multiplex type

Specify how the block packs the signals into the CAN message at each timestep:

- **Standard:** The signal is packed at each timestep.
- **Multiplexor:** The **Multiplexor** signal, or the mode signal is packed. You can specify only one **Multiplexor** signal per message.
- **Multiplexed:** The signal is packed if the value of the **Multiplexor** signal (mode signal) at run time matches the configured **Multiplex value** of this signal.

For example, a message has four signals with the following types and values.

Signal Name	Multiplex Type	Multiplex Value
Signal-A	Standard	N/A
Signal-B	Multiplexed	1
Signal-C	Multiplexed	0
Signal-D	Multiplexor	N/A

In this example:

- The block packs Signal-A (Standard signal) and Signal-D (Multiplexor signal) in every timestep.
- If the value of Signal-D is 1 at a particular timestep, then the block packs Signal-B along with Signal-A and Signal-D in that timestep.
- If the value of Signal-D is 0 at a particular timestep, then the block packs Signal-C along with Signal-A and Signal-D in that timestep.
- If the value of Signal-D is not 1 or 0, the block does not pack either of the Multiplexed signals in that timestep.

Multiplex value

This option is available only if you have selected the **Multiplex type** to be **Multiplexed**. The value you provide here must match the **Multiplexor** signal value at run time for the block to pack the **Multiplexed** signal. The **Multiplex value** must be a positive integer or zero.

Factor

Specify the **Factor** value to apply to convert the physical value (signal value) to the raw value packed in the message. See “Conversion Formula” on page 5-39 to understand how physical values are converted to raw values packed into a message.

Offset

Specify the **Offset** value to apply to convert the physical value (signal value) to the raw value packed in the message. See “Conversion Formula” on page 5-39 to understand how physical values are converted to raw values packed into a message.

Min

Specify the minimum physical value of the signal. The default value is `-inf` (negative infinity). You can specify a number for the minimum value. See “Conversion Formula” on page 5-39 to understand how physical values are converted to raw values packed into a message.

Max

Specify the maximum physical value of the signal. The default value is `inf`. You can specify a number for the maximum value. See “Conversion Formula” on page 5-39 to understand how physical values are converted to raw values packed into a message.

Conversion Formula

The conversion formula is

$$\text{raw_value} = (\text{physical_value} - \text{Offset}) / \text{Factor}$$

where `physical_value` is the value of the signal after it is saturated using the specified **Min** and **Max** values. `raw_value` is the packed signal value.

See Also

CAN Unpack

Introduced in R2009a

CAN Unpack

Unpack individual signals from CAN messages

Library

CAN Communication

Embedded Coder/ Embedded Targets/ Host Communication

Description

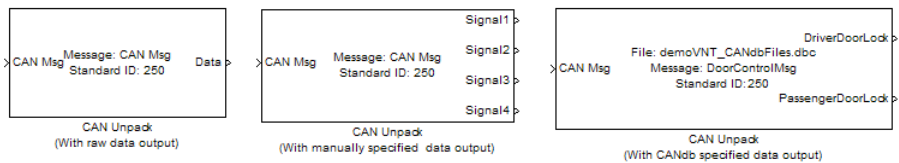

The CAN Unpack block unpacks a CAN message into signal data using the specified output parameters at every timestep. Data is output as individual signals.

Note: To use this block, you also need a license for Simulink software.

The CAN Unpack block has one output port by default. The number of output ports is dynamic and depends on the number of signals you specify for the block to output. For example, if your block has four signals, it has four output ports.

Other Supported Features

The CAN Unpack block supports:

- The use of Simulink Accelerator Rapid Accelerator mode. Using this feature, you can speed up the execution of Simulink models.

- The use of model referencing. Using this feature, your model can include other Simulink models as modular components.
- Code generation using Simulink Coder to deploy models to targets.

Note: Code generation is not supported if your signal information consists of signed or unsigned integers greater than 32-bits long.

For more information on these features, see the Simulink documentation.

Dialog Box

Use the Function Block Parameters dialog box to select your CAN message unpacking parameters.

Parameters

Data to be output as

Select your data signal:

- **raw data:** Output data as a uint8 vector array. If you select this option, you only specify the message fields. The other signal parameter fields are unavailable. This option opens only one output port on your block.
- **manually specified signals:** Allows you to specify data signals. If you select this option, use the **Signals** table to create your signals message manually.

The number of output ports on your block depends on the number of signals you specify. For example, if you specify four signals, your block has four output ports.

- **CANdb specified signals:** Allows you to specify a CAN database file that contains data signals. If you select this option, select a CANdb file.

The number of output ports on your block depends on the number of signals specified in the CANdb file. For example, if the selected message in the CANdb file has four signals, your block has four output ports.

CANdb file

This option is available if you specify that your data is input via a CANdb file in the **Data to be output as** list. Click **Browse** to find the CANdb file on your system. The

messages and signal definitions specified in the CANdb file populate the **Message** section of the dialog box. The signals specified in the CANdb file populate **Signals** table.

Note: File names that contain non-alphanumeric characters such as equal signs, ampersands, and so forth are not valid CAN database file names. You can use periods in your database name. Rename CAN database files with non-alphanumeric characters before you use them.

Message list

This option is available if you specify that your data is to be output as a CANdb file in the **Data to be output as** list and you select a CANdb file in the **CANdb file** field. You can select the message that you want to view. The **Signals** table then displays the details of the selected message.

Message

Name

Specify a name for your CAN message. The default is **CAN Msg**. This option is available if you choose to output raw data or manually specify signals.

Identifier type

Specify whether your CAN message identifier is a **Standard** or an **Extended** type. The default is **Standard**. A standard identifier is an 11-bit identifier and an extended identifier is a 29-bit identifier. This option is available if you choose to output raw data or manually specify signals. For CANdb-specified signals, the **Identifier type** inherits the type from the database.

Identifier

Specify your CAN message ID. This number must be a integer from 0 through 2047 for a standard identifier and from 0 through 536870911 for an extended identifier. If you specify **-1**, the block unpacks the messages that match the length specified for the message. You can also specify hexadecimal values using the **hex2dec** function. This option is available if you choose to output raw data or manually specify signals.

Length (bytes)

Specify the length of your CAN message from 0 to 8 bytes. If you are using **CANdb specified signals** for your output data, the CANdb file defines the length of

your message. If not, this field defaults to 8. This option is available if you choose to output raw data or manually specify signals.

Signals Table

This table appears if you choose to specify signals manually or define signals using a CANdb file.

If you are using a CANdb file, the data in the file populates this table automatically and you cannot edit the fields. To edit signal information, switch to manually specified signals.

If you have selected to specify signals manually, create your signals manually in this table. Each signal you create has the following values:

Name

Specify a descriptive name for your signal. The Simulink block in your model displays this name. The default is **Signal [row number]**.

Start bit

Specify the start bit of the data. The start bit is the least significant bit counted from the start of the message. The start bit must be an integer from 0 through 63.

Length (bits)

Specify the number of bits the signal occupies in the message. The length must be an integer from 1 through 64.

Byte order

Select either of the following options:

- **LE:** Where the byte order is in little-endian format (Intel). In this format you count bits from the start, which is the least significant bit, to the most significant bit, which has the highest bit index. For example, if you pack one byte of data in little-endian format, with the start bit at 20, the data bit table resembles this figure.

Bit Number		Bit 7	Bit 6	Bit 5	Bit 4	Bit 3	Bit 2	Bit 1	Bit 0
Data Byte Number	Byte 0	7	6	5	4	3	2	1	0
	Byte 1	15	14	13	12	11	10	9	8
	Byte 2	23	22	21	20	19	18	17	16
	Byte 3	31	30	29	28	27	26	25	24
	Byte 4	39	38	37	36	35	34	33	32
	Byte 5	47	46	45	44	43	42	41	40
	Byte 6	55	54	53	52	51	50	49	48
	Byte 7	63	62	61	60	59	58	57	56

The diagram illustrates the bit numbering for 8 bytes. A red arrow points from bit 20 (labeled 'LSB') to bit 27 (labeled 'MSB'), indicating that data is written from the least significant bit to the most significant bit. A text box notes: 'Data begins at the least significant bit and starts at 20'. Another text box notes: 'Data is written up to the most significant bit and ends at 27'.

Little-Endian Byte Order Counted from the Least Significant Bit to the Highest Address

- BE: Where the byte order is in big-endian format (Motorola). In this format you count bits from the start, which is the least significant bit, to the most significant bit. For example, if you pack one byte of data in big-endian format, with the start bit at 20, the data bit table resembles this figure.

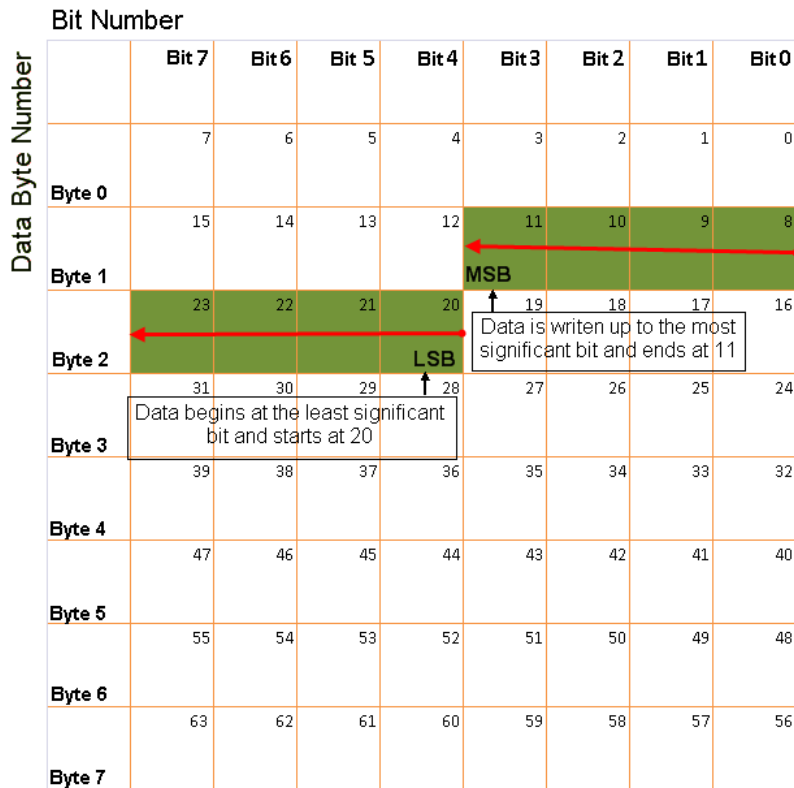

Big-Endian Byte Order Counted from the Least Significant Bit to the Lowest Address

Data type

Specify how the signal interprets the data in the allocated bits. Choose from:

- signed (default)
- unsigned
- single
- double

Multiplex type

Specify how the block unpacks the signals from the CAN message at each timestep:

- **Standard:** The signal is unpacked at each timestep.
- **Multiplexor:** The **Multiplexor** signal, or the mode signal is unpacked. You can specify only one **Multiplexor** signal per message.
- **Multiplexed:** The signal is unpacked if the value of the **Multiplexor** signal (mode signal) at run time matches the configured **Multiplex value** of this signal.

For example, a message has four signals with the following values.

Signal Name	Multiplex Type	Multiplex Value
Signal-A	Standard	N/A
Signal-B	Multiplexed	1
Signal-C	Multiplexed	0
Signal-D	Multiplexor	N/A

In this example:

- The block unpacks Signal-A (Standard signal) and Signal-D (Multiplexor signal) in every timestep.
- If the value of Signal-D is 1 at a particular timestep, then the block unpacks Signal-B along with Signal-A and Signal-D in that timestep.
- If the value of Signal-D is 0 at a particular timestep, then the block unpacks Signal-C along with Signal-A and Signal-D in that timestep.
- If the value of Signal-D is not 1 or 0, the block does not unpack either of the Multiplexed signals in that timestep.

Multiplex value

This option is available only if you have selected the **Multiplex type** to be **Multiplexed**. The value you provide here must match the **Multiplexor** signal value at run time for the block to unpack the **Multiplexed** signal. The **Multiplex value** must be a positive integer or zero.

Factor

Specify the **Factor** value applied to convert the unpacked raw value to the physical value (signal value). See “Conversion Formula” on page 5-48 to understand how unpacked raw values are converted to physical values.

Offset

Specify the **Offset** value applied to convert the physical value (signal value) to the unpacked raw value. See “Conversion Formula” on page 5-48 to understand how unpacked raw values are converted to physical values.

Min

Specify the minimum raw value of the signal. The default value is `-inf` (negative infinity). You can specify a number for the minimum value. See “Conversion Formula” on page 5-48 to understand how unpacked raw values are converted to physical values.

Max

Specify the maximum raw value of the signal. The default value is `inf`. You can specify a number for the maximum value. See “Conversion Formula” on page 5-48 to understand how unpacked raw values are converted to physical values.

Output Ports

Selecting an **Output ports** option adds an output port to your block.

Output identifier

Select this option to output a CAN message identifier. The data type of this port is **uint32**.

Output remote

Select this option to output the message remote frame status. This option adds a new output port to the block. The data type of this port is **uint8**.

Output timestamp

Select this option to output the message time stamp. This option adds a new output port to the block. The data type of this port is **double**.

Output length

Select this option to output the length of the message in bytes. This option adds a new output port to the block. The data type of this port is **uint8**.

Output error

Select this option to output the message error status. This option adds a new output port to the block. The data type of this port is **uint8**.

Output status

Select this option to output the message received status. The status is `1` if the block receives new message and `0` if it does not. This option adds a new output port to the block. The data type of this port is **uint8**.

If you do not select an **Output ports** option, the number of output ports on your block depends on the number of signals you specify.

Conversion Formula

The conversion formula is

$$\text{physical_value} = \text{raw_value} * \text{Factor} + \text{Offset}$$

where `raw_value` is the unpacked signal value. `physical_value` is the scaled signal value which is saturated using the specified **Min** and **Max** values.

See Also

CAN Pack

Introduced in R2009a

CAN I/O FIFO Support

- “CAN FIFO Basics” on page 6-2
- “Acceptance Filters” on page 6-8
- “CANdb DBC Format Databases” on page 6-10
- “CAN FIFO Loopback Tests” on page 6-11

CAN FIFO Basics

In this section...

“FIFO Mode” on page 6-2

“FIFO Mode Drivers for CAN Boards from Softing” on page 6-4

FIFO Mode

This topic describes the alternative First In First Out (FIFO) mode CAN drivers provided with the Simulink Real-Time blocks. The standard CAN drivers for the CAN boards from Softing GmbH (company.softing.com/en) program the CAN board firmware to run in Dynamic Object Buffer (DOB) mode. This mode is best suited for real-time environments where it is mandatory that the driver latency time is time deterministic. Running the firmware in Dynamic Object Buffer mode is the best choice, except for the undesired side effect of high driver latency times.

- **Sending a CAN message** — When sending a CAN message, the latency time is the time interval between the time accessing the board to provide the information for the CAN message being sent and the time the board returns the acknowledgment that the information was received by the firmware. FIFO mode blocks send messages in the order that they are input to the block. They do not take into account the priority of the input.

Note: Each CAN channel has two FIFOs, DPRAM and SRAM. The Simulink Real-Time FIFO block writes into the DPRAM FIFO. The Softing board transfers the messages from the DPRAM FIFO to the SRAM FIFO, from which the messages are transmitted onto the CAN bus. The DPRAM can buffer up to 31 messages; the SRAM can buffer up to 127 messages. This implies that while 127 messages can be buffered during congestion on the CAN bus, the 31 message limit of the DPRAM limits how many messages a model can write at one time.

- **Receiving a CAN message** — When receiving a CAN message, the latency time is the time interval between the time accessing the board to ask for current data (object data) of a certain CAN identifier and the time the board returns the actual data and other information about the CAN message.

Disadvantages of Dynamic Object Buffer mode — These latency times are mainly defined by the reaction time of the board firmware. In the case of the Softing boards, the latency time is the same for sending and receiving messages, with a fixed value of

about 40 us. If your real-time application has to send and receive a large number of CAN messages, the overall latency time can quickly become high and can make it impossible to run the application at the desired base sample time.

For example, assuming that a specific real-time application gets data from 12 CAN identifiers and transmits data by using eight CAN messages, the total number of CAN board read and write accesses adds up to 20. This results in a total CAN I/O latency time of

$$20 * 40 \text{ us} = 800 \text{ us}$$

With such an application, base sample times below 800 us are impossible even if the dynamics of the corresponding Simulink model are simple and would only need 20 us of computation time.

Advantages of Dynamic Object Buffer mode — However, even if the CAN I/O latency time in Dynamic Object Buffer mode is high, the benefit of this mode is that the latency time stays constant almost independent of the traffic volume on the CAN network. This means that the Dynamic Object Buffer mode is best suited for real-time applications that deal with only a small subset of the CAN messages going over the CAN network.

Data Types

The Simulink Real-Time CAN blocks support the following message data types. If you have Softing ISA CAN boards, you can use only the double data type for messages. If you have Softing PCI and PC/104 CAN boards, you can use either `CAN_MESSAGE` or double data types for new messages.

- `CAN_MESSAGE` — Structure that contains an array of eight unsigned 8-bit integers that contains the data. This structure also contains the ID, and the standard and extended ID range. CAN blocks can pass data of this type without requiring complicated bit packing and unpacking. This capability enables you to create simpler models. Use messages of this data type for new CAN system models. Consider updating existing CAN models to use `CAN_MESSAGE` data types.

Use `CAN Pack` blocks to pack individual signals into a CAN message for sending. Use `CAN Unpack` blocks to unpack individual signals from CAN messages,

You can construct a `CAN_MESSAGE` by using the `CAN Pack`. You can use this block to pass raw data packed elsewhere, by packing a data pattern manually. You can also use a `CANDB` file and select a predefined data pattern. If you have several

CAN_MESSAGE messages, use a Mux block to combine them into a vector that you connect to a CAN FIFO send block.

- **Double** — Double that represents 8 bytes of message in a signal. CAN blocks manipulate data of this type before passing it. Do not use this data type to create new CAN system models. The maximum size of the data frame of a CAN message is 8 bytes. This size is the same as the C data type double uses on PC-compatible systems. At the same time, the double data type is the default data type for Simulink signals. Represent the CAN data frame within a Simulink model with a scalar Simulink signal. You can represent the data frame even if the data frame has nothing in common with a double floating-point value. The Simulink Real-Time CAN library provides a Utility sublibrary that offers bit-packing and bit-unpacking blocks. Use these blocks to pack data types other than doubles into 64 bits (8 bytes or a double) as well as for the opposite operation. Simulink signals of data type double represent CAN data frames.

Updating Existing Models to Use CAN_MESSAGE Data Types

If you have Softing PCI and PC/104 CAN boards, you can update existing models to use CAN_MESSAGE data types. As a rule:

- If your existing model contains **CAN Bit-Packing** and **CAN Bit-Unpacking** blocks, replace them with the **CAN Pack** and **CAN Unpack** blocks.
- Open and reconfigure the **CAN Send** and **Receive** blocks to use CAN_MESSAGE data types.
- Remove **FIFO Mode CAN Message** and **CANDBC Translator** blocks. Updated models do not require the conversions that these blocks perform.

FIFO Mode Drivers for CAN Boards from Softing

The CAN boards from Softing support another mode, called First In First Out (FIFO) mode. In this mode the Dynamic Object Buffer mode abstraction layer in the firmware is missing, and the firmware plays the role of a slim interface between the receive and transmit FIFOs and the drivers in the real-time application code. Because of this slimmer interface, the I/O latency times are considerably smaller. Writing to the transmit FIFO takes 4 us per CAN message and reading one event (CAN message) from the receive FIFO takes 17 us. Both of these latency times are smaller than the 40 us for Dynamic Object Buffer mode. While writing to the transmit FIFO is efficient, this is not the case for reading from the receive FIFO. Because the receive FIFO contains all of the CAN messages (identifiers) going over the CAN network, a lot of data (CAN

messages) has to be read out of the FIFO even if their data is not used in the real-time application. Because of the FIFO structure, events (messages) have to be read until the message is returned that is propagated to the real-time application. The driver code for reading the receive FIFO is principally a while loop, and this can add the problem of nondeterministic latency times.

You resolve the latency time issue in the Simulink Real-Time CAN FIFO drivers by defining a receive FIFO read depth that is a constant number during real-time application execution. For example, if you assume a FIFO read depth of 5, each time the Read Receive FIFO driver block is executed at the block sample time, the driver code reads and returns five events (messages) from the receive FIFO. This is independent of how many events the FIFO currently contains. There can be only two messages received in the FIFO and the third to fifth read attempt might just return the "No new event" code. Nevertheless, because the FIFO read latency does not exceed 17 us regardless of the event read out of the FIFO, the latency time becomes deterministic and is the Read FIFO Depth multiplied by 17 us. The driver block returns all new events and therefore all CAN messages going over the network. If only a small subset of the CAN messages received must be processed in the real-time application, the total latency can easily exceed the latency encountered with the Dynamic Object Buffer mode for the same application. There is another restriction specific to the FIFO mode concept. You should not use more than one Read Receive FIFO block in a Simulink model, because a new event (message) read by one block instance cannot be read again by another block instance (the event was removed from the FIFO buffer). Therefore the entire CAN receive part has to be concentrated in one Read Receive FIFO block in your model. For the write transmit FIFO side, this restriction does not apply. Here you can use as many instances as you want.

The Setup block for the CAN FIFO mode controls the CAN acceptance filters of the CAN controller. The acceptance filter defines a range of CAN messages not to be forwarded to the receive FIFO. Filtering out unwanted CAN messages can drastically reduce the read receive FIFO latency time because the unwanted messages do not reach the receive FIFO. Unfortunately, the acceptance filter process uses binary evaluation, which does not allow filtering messages below and above a certain decimal range. Therefore the use of the acceptance filter only resolves the problem for a small subset of CAN system models. See "Acceptance Filters" on page 6-8 for more information on this.

Look again at the example of 12 messages to be received and eight messages to be transmitted. If those 20 messages with their specific identifiers are the only messages going over the CAN network (100% usage ratio), then the total latency time is

$$12 \cdot 17 \text{ us} + 8 \cdot 4 \text{ us} = 236 \text{ us}$$

This is considerably smaller than the 800 μ s that results when you use Dynamic Object Buffer mode drivers.

For the next case, assume that there are only 12 additional messages going regularly over the network that do not need to be processed by the real-time application. Additionally, assume that those messages cannot be filtered by the CAN controller acceptance filter. Then the total latency time increases to

$$12 \cdot 17 \mu\text{s} + 20 \cdot 4 \mu\text{s} = 284 \mu\text{s}$$

There is little impact on the final result. The FIFO mode drivers are best suited for either CAN network monitoring or low-latency CAN systems where the ratio between the number of messages to be processed and the number of total messages going over the network is high.

FIFO mode drivers are especially suited for network monitoring, because FIFO mode can return additional information such as the bus state or the reception of error frames. Dynamic Object Buffer mode drivers do not allow querying such information.

This documentation only covers the differences between the Dynamic Object Buffer mode drivers (standard drivers) and the FIFO mode drivers introduced here. It assumes that you are familiar with the Dynamic Object Buffer mode drivers and have run without an error one of the loopback tests provided with the Simulink Real-Time product.

If you use FIFO mode drivers in your model, you must replace the Dynamic Object Buffer mode blocks (Setup, Send, Receive) with FIFO mode driver blocks. The CAN-AC2 boards from Softing do not let you run the two CAN ports in different modes. Therefore the mode has to be same for both ports, but you can use more than one CAN board and run the boards in different modes just by selecting different I/O driver blocks.

As mentioned in the standard CAN topic, you should not use the CAN-AC2 (ISA) for new projects. Instead use the CAN-AC2-PCI. Therefore, FIFO mode drivers are only provided for the CAN-AC2-PCI and the CAN-AC2-104 boards.

CAN-AC2-PCI (FIFO) with SJA1000 Controller

The CAN-AC2-PCI driver blocks support the CAN-AC2-PCI board using FIFO mode. The Philips SJA1000 chip is used as the CAN controller in this configuration and supports both standard and extended identifier ranges in parallel. The driver block set for this board is found in the Simulink Real-Time I/O block library in the group CAN/Softing. The CAN-AC2-PCI SJA 1000 block group contains the FIFO mode CAN subgroup.

CAN-AC2-104 (FIFO) with SJA1000 Controller

The CAN-AC2-104 driver blocks support the CAN-AC2-104 (PC/104) board using FIFO mode. The Philips SJA1000 chip is used as the CAN controller in this configuration and supports both standard and extended identifier ranges in parallel. The driver block set for this board is found in the Simulink Real-Time I/O block library in the group CAN/Softing. The CAN-AC2-104 SJA 1000 block group contains the FIFO Mode subgroup.

Acceptance Filters

You can use the CAN controller acceptance filters to select received messages by identifier for writing into the receive FIFO. Therefore, fewer read attempts are required to get the messages of importance to the real-time application.

The behavior of the acceptance filter is described for standard and extended identifier ranges individually (one for standard identifiers and one for extended identifiers). Each acceptance filter is defined by a mask parameter and a code parameter.

The mask parameter defines, for each bit of the identifier, whether the filtering process cares about this bit or not. A 0 means “don't care” and a 1 means “do care.”

The code parameter then defines, for each bit of the identifier, that the filtering process cares about (defined by the mask parameter), what the bit value has to be (0 or 1).

For standard identifiers the mask parameter and code parameter must both be in the range 0 to 2047. For extended identifiers the mask parameter and code parameter must both be in the range 0 to $2^{29} - 1$.

The filtering process evaluates the following binary expression:

```
and( xor( mask, identifier ), code )
```

If all bits of the resulting value are 0, the message with this identifier is accepted. If a bit is 1, the message is voided.

According to this description, acceptance filters work using binary evaluation, while most systems differentiate messages (identifiers) in a decimal or hexadecimal manner. As a consequence, it is possible to filter messages, whose identifiers are above a certain decimal number. The opposite (identifiers below a certain decimal number) cannot be achieved in a general way.

The default values for the mask parameter and the code parameter in the FIFO setup driver block are both 0. Because the filtering expression evaluates to 0, all incoming messages reach the receive FIFO (no filtering takes place). The parameter values are defined using decimal numbers. You can use the MATLAB function `hex2dec` to define hexadecimal numbers in the dialog box entry.

For example, assume a CAN network model where messages with the following identifiers (standard) are crossing the CAN network:

2-30, 48-122 (decimal)

Additionally, only incoming messages 4-29 must be processed by the real-time application. Ideally, all messages not having identifiers 4-29 would be filtered out, but the mask and code parameters do not allow this exact scheme. The closest you can achieve is filtering out the messages with identifiers above 31 by using value 2047-31 = 2016 for the mask parameter and value 0 for the code parameter. The messages with identifiers 0, 1, 2, and 3 cannot be filtered out and are returned by the FIFO read driver block, even if they do not need to be processed by the real-time application.

CANdb DBC Format Databases

You can use CANdb DBC files to specify the packing and unpacking of CANdb messages in a real-time application. To access a CANdb DBC format file,

- 1 Drag a **CAN Pack** block into your model,
- 2 Configure the **Data is input as** parameter to **CANdb specified signals**
- 3 Configure the **CANdb file** parameter to reference your CANdb DBC format file

You use the **CAN Unpack** to unpack the signals from a CAN message.

CAN FIFO Loopback Tests

The Simulink Real-Time product contains the following examples that illustrate the use of the Softing CAN FIFO blocks. The models use `CAN_MESSAGE` data types. Each example requires a loopback cable connected between the two ports on the board. The examples send messages on port 1 and receive messages on port 2.

These models have the following naming conventions:

- Model names appended with **s** — Output is a vector of `CAN_MESSAGE` data with length equal to the value of the **FIFO read depth** parameter. This length is also the maximum number of messages that the block returns. The second output port returns the number of messages that are present in the output.
- Model names appended with **sf** — Output contains one `CAN_MESSAGE` message at a time. The block calls the function-call output between **0** and **FIFO read depth** number of times, depending on how many messages are in the FIFO.

Example	Shows CAN I/O Communication Using FIFO Mode of the...
“CAN I/O FIFO Mode - Simple Use Case (with <code>CAN_MESSAGE</code>)”	Softing CAN-AC2-PCI board. It illustrates the basic functionality of the board.
“CAN I/O FIFO Mode - Simple Use Case (with <code>CAN_MESSAGE</code> and Function Call Output)”	Softing CAN-AC2-PCI board. It illustrates CAN I/O communication using a function call output format for the FIFO Read block.

CAN I/O FIFO Blocks

Softing CAN-AC2-PCI with Philips SJA1000 FIFO Setup

Softing CAN-AC2-PCI with Philips SJA1000 FIFO Setup block

Library

Simulink Real-Time Library for CAN

Description

The **Setup** block defines general settings of the installed CAN board(s). The CAN driver blocks for this board support up to 16 boards for each target system, making up to 32 CAN ports available. For each board in the target system, you can use one **Setup** block in a model.

Block Parameters

Board

Defines the board being accessed by this driver block instance. If multiple boards are present in the target computer, you can use the board number (1...16) to differentiate the boards. The physical board referenced by the board number depends on the **PCI Slot** parameter. If just one board is present in the target system, select board number 1.

CAN 1 - physical bus

Defines the physical CAN bus type of CAN port 1. In the board's standard configuration, only high-speed CAN is supported. By extending the board with low-speed CAN piggyback modules, you can also select low-speed CAN as the physical bus. Do not change this value to low-speed if a module is not present for the corresponding CAN port. If the module is present (see the Softing user manual for how to install the modules), you can select between high-speed and low-speed CAN here.

CAN 1 - baud rate

Defines the most common baud rates for CAN port 1. If your model requires a special baud rate, select the value `User defined`.

CAN 1 - user defined baud rate

If you select `User defined` from the CAN 1 Baud rate list, enter the four values for the timing information. The vector elements have the following meanings:

```
[ Prescaler, Synchronization-Jump-Width, Time-Segment-1,  
Time-Segment-2 ]
```

For more information about these values, see the Softing user manual for this board.

CAN 1 - acceptance

Defines the acceptance filters for the CAN 1 port. Because the receive FIFO is filled with arbitrary CAN messages going over the bus, the use of the CAN controller acceptance filters becomes important to filter out unwanted messages already at the controller level. This acceptance filter information is provided by a row vector with four elements in which the first two are used to define the acceptance mask and acceptance code for standard identifiers and the latter two for extended identifiers. The default value defined by the `Setup` block does not filter the messages. For information on how to define the acceptance information to filter certain messages, see “Acceptance Filters” on page 6-8.

CAN 2 - physical bus

Defines the physical CAN bus type of CAN port 2. In the board's standard configuration, only high-speed CAN is supported. By extending the board with low-speed CAN piggyback modules, you can also select low-speed CAN as the physical bus. Do not set this value should to low-speed if a module is not present for the corresponding CAN port. If the module is present (see the Softing user manual on how to install the modules), you can select between high-speed and low-speed CAN here.

CAN 2- baud rate

Defines the most common baud rates for CAN port 2. If your model requires a special baud rate, select the value `User defined`.

CAN 2 - user defined baud rate

If you select `User defined` from the CAN 2 baud rate list, enter the four values for the timing information. The vector elements have the following meanings:

```
[ Prescaler, Synchronization-Jump-Width, Time-Segment-1,  
Time-Segment-2 ]
```

For more information about these values, see the Softing user manual for this board.

CAN 2 - acceptance

Defines the acceptance filters for the CAN 2 port. Because the receive FIFO is filled with arbitrary CAN messages going over the bus, the use of the CAN controller acceptance filters becomes important to filter out unwanted messages already at the controller level. This acceptance filter information is provided by a row vector with four elements in which the first two are used to define the acceptance mask and acceptance code for standard identifiers and the latter two for extended identifiers. The default value defined by the **Setup** block does not filter messages. For information on how to define the acceptance information to filter certain messages, see “Acceptance Filters” on page 6-8.

Enable error frame detection

If the CAN controller should detect error frames and forward these to the Receive FIFO, select this box. Selecting this box makes sense for network monitoring, where you want to be informed about all events going over the bus. For low-latency-time system models, selecting this box might increase the **FIFO Read** driver block latency time because the receive FIFO gets filled with additional events.

Initialization command structure and Termination (struct)

Define the CAN messages sent during initialization and termination of the **Setup** block. For more information, see the standard CAN driver documentation in “Initialization and Termination CAN Messages” on page 4-11.

Termination

Define the CAN messages sent during termination of the **Setup** block. For more information, see the standard CAN driver documentation in “Initialization and Termination CAN Messages” on page 4-11.

Show bus-off status output

Select this check box to enable the bus-off status output port. The output signal can be 1 (bus-off state); otherwise, it is 0. If the bus-off status persists, the block optionally initiates recovery, depending on the setting of **Bus-off recovery**.

Clear this check box to disable the output port.

Bus-off recovery

Use this parameter to specify how the model is to perform bus-off recovery for the CAN network.

From the list, select:

- **Off**

Does not perform bus-off recovery.

- **Auto**

Upon detection, the model waits 1 second to see if the bus-off state persists. After 1 second, bus-off recovery occurs.

- **Manual Trigger Input**

Enables you to input a signal when you want bus-off recovery to occur. Selecting this option creates an input port for the **Setup** block.

PCI slot (-1:autosearch)

If only one board of this type is in the target computer, enter - 1 to locate the board.

If two or more boards of this type are in the target computer, enter the bus number and the PCI slot number of the board associated with this driver block. Use the format **[BusNumber,SlotNumber]**.

To determine the bus number and the PCI slot number, type:

```
tg = slrt;  
getPCIInfo(tg, 'installed')
```

The board allows you to terminate each of the two CAN ports separately by means of DIP switches at the rear panel. Both CAN ports must be terminated if you use the loopback model provided to test the board and drivers. Refer to the Softing user manual on how to set the DIP switches.

External Websites

- www.can-cia.org
- company.softing.com/en

Softing CAN-AC2-PCI with Philips SJA1000 FIFO Write

Softing CAN-AC2-PCI with Philips SJA1000 FIFO Write Driver block

Library

Simulink Real-Time Library for CAN

Description

The **FIFO Write** driver block writes CAN messages into the transmit FIFO. The firmware running in FIFO mode processes the information in the transmit FIFO and finally puts the constructed CAN messages onto the bus. This block dynamically detects the data type and signal size of the signal you connect to the input port. If you use this block inside an enabled subsystem, the block sends the message only when you enable the subsystem.

If you use the `CAN_MESSAGE` data type:

If the block input is a `CAN_MESSAGE` data type, use **CAN Pack** blocks to pack individual signals into a CAN message. If you use **CAN Pack** blocks to prepare each message, the **FIFO Write** block reads the `CAN_MESSAGE` data. To combine several messages into a vector of `CAN_MESSAGE` data that the **FIFO Write** block sends, use a **Mux** block. Use the **Port (if input is CAN_MESSAGE)** parameter to select the port to which to send the `CAN_MESSAGE` data.

Tip To prepare a remote frame, use the **CAN Pack** block with the **Remote frame** check box selected. To request the current value, send the remote frame to the responding subsystem.

If you use the double data type (legacy):

If the block input consists of double values in a matrix, the block has one input port of type double. At this port, the required information must be provided to construct

valid CAN messages to be written into the transmit FIFO. For each CAN message, five elements are passed:

Port

The value can be either 1 (port 1) or 2 (port 2) and defines the port the CAN message is sent from.

Identifier

Identifier of the CAN message to be sent. If it is a standard CAN message the valid range is 0 to 2047. If the CAN message is extended, the range is 0 to $2^{29}-1$.

Identifier type

The value can be either 0 (standard identifier range) or 1 (extended identifier range) and defines the identifier type of the outgoing CAN message.

Data frame size

The value can be in the range of 0 to 8 and defines the data frame size in bytes of the outgoing CAN message.

Data

Data for the data frame itself. Use the `CAN Bit-Packing` block to construct the data as double values in a matrix.

Because this information can be dynamically changed in FIFO mode during real-time application execution, the information is provided at the block input instead of you setting them through block parameters. To be able to transmit more than one CAN message per block instance, a matrix signal is used as a container.

The dimension of the matrix signal entering the block has to be $n*5$, where n is the number of CAN messages to be sent by this block instance. Therefore each row of the matrix signal defines one CAN message and each row combines the five elements of information defined above (in this order).

For examples of constructing the matrix signal for the `FIFO Write` block, see “CAN FIFO Loopback Tests” on page 6-11.

For certain models, you might make the writing of a CAN message into the transmit FIFO dependent on the model dynamics. For this case, the matrix signal can also be of dimension $n*6$ instead of $n*5$. In this case, the sixth column defines whether the corresponding CAN message is written into the transmit FIFO (1) or not (0).

Block Parameters

Board

Define the board used to send the CAN messages defined by this block instance. For more information about the meaning of the board number, see the **Setup driver** block. If just one board is present in the target system, you should select 1.

Show input count port

Select this check box to track the number of inputs to the block and add a second input port, *N*, to the block. If this port value exceeds the size of the input vector of `CAN_MESSAGE` messages, the block limits the transfer to the size of the input vector. If this port value is smaller than the `CAN_MESSAGE` input vector size, the block transfers data up to the size of this port value. For example, assume an input of 10×5 matrix. If you then input a 5 to input port *N*, the block sends only the first five messages. In an $n \times 6$ matrix, the last entry in the row is still the individual message enabled, but the block checks only messages up to *n*. If the input is a matrix of doubles, the block ignores the value of the **Port** parameter. The block considers the port as part of the data.

If this check box is cleared, the block sends all elements of the input vector.

Port (if input is CAN_MESSAGE)

If the message is a `CAN_MESSAGE` data type, from the list, select 1 or 2 for the port to send the message through. The block sends a message to a single CAN port. If you want to send messages to different ports in a model, use multiple **FIFO Write** blocks. This input port is the first one on the block. Its input is a vector or single `CAN_MESSAGE` message.

If the message consists of double values in a matrix, changing this parameter does not change the block behavior. You specify the port number in the CAN message. A single **FIFO Write** block can send messages through both ports.

Show status output port

Select this to enable the status output port. If the box is cleared, the block does not have an output port. If enabled, a port is shown. The signal leaving the block is a vector of type `CAN_MESSAGE` or double depending on which data type you are using for your messages, in which the number of elements depends on the signal dimension of the block input port. There is one element for each CAN message written into the transmit FIFO and the value is identical to the return argument of function `CANPC_send_data`, described in the Softing user manual. Refer to that manual for more information. The function return codes are:

Code	Description
0	Function executed without detecting an error.
-1	Function encountered an error.
-4	Timeout firmware communication.
-99	Board not initialized.

Sample time

Defines the sample time at which the **FIFO Write** block is executed during a real-time application run.

You can use as many instances of the **FIFO Write** block in the model as required. For example, by using two instances of the block, you can send CAN messages at different sample times. Or you can use multiple instances to structure your model more efficiently.

External Websites

- www.can-cia.org
- company.softing.com/en

Softing CAN-AC2-PCI with Philips SJA1000 FIFO Read

Softing CAN-AC2-PCI with Philips SJA1000 FIFO Read block

Library

Simulink Real-Time Library for CAN

Description

The **FIFO Read** driver block reads CAN messages from the receive FIFO. The firmware running in FIFO mode puts received events (CAN messages) into the receive FIFO from which the FIFO Read driver reads it.

If you choose `CAN_MESSAGE` data type as the output, use **CAN Unpack** blocks to unpack individual signals from a CAN message.

Tip To process a remote frame, use the **CAN Unpack** block with the **Output remote** check box selected to enable the Remote port. When the Remote port becomes `true`, send the current value to the requesting subsystem.

If you choose matrix as the output data type, the **FIFO Read** driver block has one output port of type double. The signal of this port is a matrix of size $m \times 6$, where m is the **FIFO Read** depth defined in the block dialog box (see below). For example, if the FIFO read depth is 5, then the matrix signal of port 1 has size 5×6 . Therefore, one row for each event is read out of the receive FIFO (no new message is considered an event as well). For examples showing how to extract data from the matrix signal, see “CAN FIFO Loopback Tests” on page 6-11.

If you choose output as double values in a matrix, each row with its six elements contains the information defining a CAN message:

Port

The value can be either 1 (port 1) or 2 (port 2) and reports the port at which the CAN message was received.

Identifier

Identifier of the CAN message being received. If it is a standard CAN message the range is 0 to 2047. If it is an extended CAN message, the range is 0 to $2^{29}-1$.

Event type

This value defines the type of event read from the receive FIFO. The following values are defined in the Softing user manual.

Events	Description
0	No new event.
1	Standard data frame received.
2	Standard remote frame received.
3	Transmission of a standard data frame is confirmed.
4	
5	Change of bus state.
6	
7	
8	Transmission of a standard remote frame is confirmed.
9	Extended data frame received.
10	Transmission of an extended data frame is confirmed.
11	Transmission of an extended remote frame is confirmed.
12	Extended remote frame received.
13	
14	
15	Error frame detected.

Data frame size

If a data frame has been received, the length of the data in bytes is reported by this element. Possible values are 0 to 8.

Timestamp

Time at which the event was received. The resolution of the timestamp counter is 1 us.

Data

Data of the data frame itself returned as a CAN_MESSAGE or double value (8 bytes) depending on which data type you are using for your messages. Use the **CAN Unpack** block to extract the data from the CAN_MESSAGE data value. Use the **CAN Bit-Unpacking** block to extract the data from the double value.

Block Parameters

Board

Defines the board used to send the CAN messages defined by this block instance. For more information about the meaning of the board number, see the **Setup** driver block. If one board is present in the target system, select board number 1.

Output format

From the list, select:

- **Matrix of doubles (legacy)**

Formats messages as double values in a matrix. See “Description” on page 7-10 for details on this message format.

- **Vector of CAN_MESSAGE plus count**

Formats messages as vectors of CAN_MESSAGE structures.

Selecting this option enables the **Port** parameter. It also creates an *N* output port that contains the number of valid entries in the CAN_MESSAGE data vector. The block interprets the **FIFO read depth** value as the size of the vector. The block outputs up to **FIFO read depth** number of messages. For example, if you enter a read depth of 3, but the receive FIFO has only two messages, the output vector has only two messages. The “CAN I/O FIFO Mode - Simple Use Case (with CAN_MESSAGE)” example illustrates the use of this parameter.

- **Function call for each CAN_MESSAGE**

Formats messages as vectors of CAN_MESSAGE structures.

Selecting this option enables the **Port** parameter. It also creates a function-call output (f()) output port. This port contains a function-call for a single

CAN_MESSAGE data element. The block repeats the function-call for each message from the FIFO, up to the value of **FIFO read depth**. You input this function-call output into a function-call subsystem. The “CAN I/O FIFO Mode - Simple Use Case (with CAN_MESSAGE and Function Call Output)” example illustrates the use of this parameter.

Port

CAN_MESSAGE only. From the list, select 1 or 2 for the input port. The block reads the message from that FIFO (1 or 2). Its output is a vector of CAN_MESSAGE messages. If you want to read from both ports, use two FIFO Read blocks, one for each port. Selecting Vector of CAN_MESSAGE plus count for **Output format** enables this parameter.

Selecting Matrix of doubles (legacy) or Function call for each CAN_MESSAGE for the **Output format** parameter disables this parameter. The block ignores the port. In this case, the block reads from both ports and records the port for each message in the output matrix.

FIFO read depth

Defines the number of receive FIFO read attempts. Each time the block is executed it reads this fixed number of events (CAN messages), which leads to a deterministic time behavior regardless of the number of events currently stored in the receive FIFO. The Read depth (m) also defines the size of the matrix signal (m*6) leaving the first output port. If an event is not currently stored in the receive FIFO, the FIFO is read anyway, but the event type is reported as 0 (no new event).

Show status output port

Select this to enable the status output port (S). If the box is cleared (disabled), the block has one output port for the events (D). If enabled, a second port is shown. The signal leaving that port is a vector of doubles, with two elements:

[Number of lost messages (events), Bus state]

The first element returns the current value of the lost messages counter. The receive FIFO can store up to 127 events. If the receive FIFO is not regularly accessed for reading events, the FIFO is filled and the lost messages counter starts to count up. This is an indicator that events (messages) will be unavoidably lost. The second element returns the current bus state. Possible values are

Code	Description
0	Error active.

Code	Description
1	Error passive.
2	Bus off.

Sample time

Defines the sample time at which the **FIFO Read** block is executed during a real-time application run.

Note: Use only one instance of this block per physical CAN board in your model. Otherwise, you might get the unwanted behavior that one instance would read events that must be processed by blocks connected to the other, second instance.

External Websites

- www.can-cia.org
- company.softing.com/en

Softing CAN FIFO Read Filter

Softing CAN FIFO Read Filter block (architecture independent)

Library

Simulink Real-Time Library for CAN

Description

The **FIFO Read Filter** block is a utility block for the CAN FIFO driver block set, and is used to filter events out of the signal leaving the **FIFO Read** driver block (also known as the event matrix). It is usually connected to the first output port of the **FIFO Read** driver block. Because the **FIFO Read Filter** block does not actually access the CAN board or other device, it is independent of the bus architecture of the board.

The block code walks through the rows of the incoming event matrix signal and looks for events matching the criteria defined in the block dialog box. If an event matches, the entire event information (row) is written to the first output port. If more than one row matches the criteria, the later event overwrites the earlier event.

The block has one input port and two output ports, all of type **double**. The input port accepts a matrix signal of size $m \times 6$. The first output port, a row vector of size 1×6 , outputs the filtered event. The second, a scalar, outputs the number of matching events the filter block has processed.

Block Parameters

CAN port

Defines the filter criterion for the CAN port. From the list, select **Any**, **1**, or **2**.

Message type command

Defines the filter criterion for the event types. This entry consists of a concatenation of space-delimited keywords:

Keyword	Description
SDF	Standard data frame.

Keyword	Description
SRF	Standard remote frame.
EDF	Extended data frame.
ERF	Extended remote frame.
EF	Error frame.
NE	No new event.
CBS	Change of bus state.

Message type selection mode

Defines how the event type (message type) listed in **Message type command** parameter is treated. If you select **Include**, the event type criterion is the sum of the concatenated keywords. If you select **Exclude**, the event type criterion is equal to all event types minus the sum of the concatenated keywords.

Identifier(s)

Defines the filter criterion for the CAN message identifiers. A set of identifiers can be provided as a row vector.

Identifier selection mode

Defines how the identifier criterion entered in the **Identifier(s)** parameter is treated. If you select **Include**, the identifier criterion is the sum of all specified identifiers. If you select **Exclude**, the identifier criterion is equal to all identifiers minus the specified identifiers.

You can use as many instances of this block in your model as required. Usually, you connect several instances in parallel to the output of the **FIFO Read** driver block to filter out particular messages or events. For examples, see “CAN FIFO Loopback Tests” on page 6-11.

External Websites

- www.can-cia.org
- company.softing.com/en

Softing CAN-AC2-PCI with Philips SJA1000 FIFO Read XMT Level

Softing CAN-AC2-PCI with Philips SJA1000 FIFO Read XMT Level block

Library

Simulink Real-Time Library for CAN

Description

The **FIFO Read XMT Level** driver block reads the current number of CAN messages stored in the transmit FIFO to be processed by the firmware. The transmit FIFO can store up to 31 messages. If it is full and a **FIFO Write** driver block tries to add another message to the transmit FIFO, the passed messages are lost. You can use this driver block to check for this condition and take action. For example, you could stop the execution or wait for a non-full transmit FIFO.

The block has a single output port of type double, returning a scalar value containing the current transmit FIFO level (number of messages to be processed).

Block Parameters

Board

Defines the board accessed to read the current transmit FIFO level. For more information about the meaning of the board number, see the **Setup** driver block. If just one board is present in the target system, select board number 1.

Sample time

Defines the sample time at which the **FIFO Read XMT Level** driver block is executed during a real-time application run.

External Websites

- www.can-cia.org

- company.softing.com/en

Softing CAN-AC2-PCI with Philips SJA1000 FIFO Reset XMT

Softing CAN-AC2-PCI with Philips SJA1000 FIFO Reset XMT block

Library

Simulink Real-Time Library for CAN

Description

The **FIFO Reset XMT** driver block resets the transmit FIFOs. This deletes the messages currently stored in the transmit FIFO and reset the level counter to 0. As an example, you can use this driver block to reset the transmit FIFO after having detected a fault condition.

The block has a single input port of type double. If a scalar value of 1 is passed, the transmit FIFO is reset. If a scalar value of 0 is passed, nothing is done.

Block Parameters

Board

Defines the board accessed to reset the transmit FIFO. For more information about the meaning of the board number, see the **Setup** driver block. If just one board is present in the target system, select board number 1.

Sample time

Defines the sample time at which the **FIFO Reset XMT** driver block is executed during a real-time application run.

External Websites

- www.can-cia.org
- company.softing.com/en

Softing CAN-AC2-PCI with Philips SJA1000 FIFO Read RCV Level

Softing CAN-AC2-PCI with Philips SJA1000 FIFO Read RCV Level block

Library

Simulink Real-Time Library for CAN

Description

The **FIFO Read RCV Level** driver block reads the current number of CAN messages stored in the receive FIFO. The receive FIFO can store up to 127 events (messages). If it is full and a **FIFO Read** driver block does not attempt to read the stored events, new incoming events are lost, as shown by increments to the lost message counter. You can use this driver block to check for this condition and take action, such as stopping the execution or resetting the receive FIFO.

The block has a single output port of type double, returning a scalar value containing the current receive FIFO level (number of messages to be processed).

Block Parameters

Board

Defines the board accessed to read the current receive FIFO level. For more information about the meaning of the board number, see the **Setup** driver block. If just one board is present in the target system, select board number 1.

Sample time

Defines the sample time at which the **FIFO Read RCV Level** driver block is executed during a real-time application run.

External Websites

- www.can-cia.org

- company.softing.com/en

Softing CAN-AC2-PCI with Philips SJA1000 FIFO Reset RCV

Softing CAN-AC2-PCI with Philips SJA1000 FIFO Reset RCV block

Library

Simulink Real-Time Library for CAN

Description

The **FIFO Reset RCV** driver block resets the receive FIFO. This deletes the messages currently stored in the receive FIFO and reset the level counter to 0. As an example, you can use this driver block to reset the receive FIFO after having detected a fault condition.

The block has a single input port of type double. If a scalar value of 1 is passed, the transmit FIFO is reset. If a scalar value of 0 is passed, nothing is done.

Block Parameters

Board

Defines the board accessed to reset the receive FIFO. For more information about the meaning of the board number, see the **Setup** driver block. If just one board is present in the target system, select board number 1.

Sample time

Defines the sample time at which the **FIFO Reset RCV** driver block is executed during a real-time application run.

External Websites

- www.can-cia.org
- company.softing.com/en

Softing CAN-AC2-104 with Philips SJA1000 FIFO Setup

Softing CAN-AC2-104 with Philips SJA1000 FIFO Setup block

Library

Simulink Real-Time Library for CAN

Description

The **FIFO Setup** driver block defines general settings of the installed CAN boards. The CAN driver blocks for this board support up to three boards for each target system, making up to six CAN ports available. For each board in the target system, you must use exactly one Setup driver block.

Block Parameters

Board

Defines the board accessed by this driver block instance. If multiple boards are present in the target computer, you can use the board number (1...3) to differentiate the boards. The physical board referenced by the board number depends on the **PCI Slot** parameter.

CAN 1 - baud rate

Defines the most common baud rates for CAN port 1. If your model requires a special baud rate, select the value **User defined**.

CAN 1 - user defined baud rate

If you selected **User defined** from the CAN 1 - baud rate list, enter four values for the timing information. The vector elements have the following meanings:

[Prescaler, Synchronization-Jump-Width, Time-Segment-1, Time-Segment-2]

For more information about these values, see the Softing user manual for this board.

CAN 1 - acceptance

Defines the acceptance filters for CAN port 1. Because the receive FIFO is filled with arbitrary CAN messages going over the bus, the use of the CAN controller acceptance filters becomes important to filter out unwanted messages already at the controller level. This acceptance filter information is provided by a row vector with four elements in which the first two are used to define the acceptance mask and acceptance code for standard identifiers and the latter two for extended identifiers. The default value defined by the **Setup** block does not filter messages. For information on how to define the acceptance information to filter certain messages, see “Acceptance Filters” on page 6-8.

CAN 2 - baud rate

Defines the most common baud rates for CAN port 2. If your model requires a special baud rate, select the value **User defined**.

CAN 2- user defined baud rate

If you selected **User defined** from the CAN 1 - baud rate list, enter four values for the timing information. The vector elements have the following meanings:

[Prescaler, Synchronization-Jump-Width, Time-Segment-1, Time-Segment-2]

For more information about these values, see the Softing user manual for this board.

CAN 2 acceptance

Defines the acceptance filters for CAN port 2. Because the receive FIFO is filled with arbitrary CAN messages going over the bus, the use of the CAN controller acceptance filters becomes important to filter out unwanted messages already at the controller level. This acceptance filter information is provided by a row vector with four elements in which the first two are used to define the acceptance mask and acceptance code for standard identifiers and the latter two for extended identifiers. The default value defined by the **Setup** block does not filter messages. For information on how to define the acceptance information to filter certain messages, see “Acceptance Filters” on page 6-8.

Enable error frame detection

Defines whether the CAN controller should detect error frames and forward these to the receive FIFO. Selecting this box makes sense for network monitoring, where you want to be informed about all events going over the bus. For low-latency-time models, selecting this box might increase the **FIFO Read** driver block latency, because the receive FIFO is filled with additional events.

Initialization command structure and Termination

Defines CAN messages sent during initialization and termination of the **Setup** block. For more information, see the standard CAN driver documentation in “Initialization and Termination CAN Messages” on page 4-11.

Termination

Defines CAN messages sent during termination of the **Setup** block. For more information, see the standard CAN driver documentation in “Initialization and Termination CAN Messages” on page 4-11.

Show bus-off status output

Select this check box to enable the bus-off status output port. The output signal can be 1 (bus-off state); otherwise, it is 0. If the bus-off status persists, the block optionally initiates recovery, depending on the setting of **Bus-off recovery**.

Clear this check box to disable the output port.

Bus-off recovery

Use this parameter to specify how the model is to perform bus-off recovery for the CAN network.

From the list, select:

- **Off**

Does not perform bus-off recovery.

- **Auto**

Upon detection, the model waits 1 second to see if the bus-off state persists. After 1 second, bus-off recovery occurs.

- **Manual Trigger Input**

Enables you to input a signal when you want bus-off recovery to occur. Selecting this option creates an input port for the **Setup** block.

I/O base address

Defines the I/O base address of the board to be accessed by this block instance. The I/O base address is given by the DIP switch setting on the board itself. The I/O address range is 4 bytes of I/O address space. It is mainly used to identify the memory base address the board should use. See the Softing user manual for this board on how you can set the I/O base address. The I/O base address entered in this control must correspond with the DIP switch setting on the board. If more than one board is

present in the target system, you must enter a different I/O base address for each board. In this case, the I/O base address itself defines which board is referenced by which board number.

Memory base address

Defines the memory base address of the board to be accessed by this block instance. The memory base address is a software setting only (the board does not have a corresponding DIP switch). The memory address range is 4 KB. If more than one board is present in the target system, you must enter a different memory base address for each board and verify that the defined address ranges do not overlap. Because the Simulink Real-Time kernel only reserves a subset of the address range between 640 KB and 1 MB for memory-mapped devices, the address ranges must be within the following range:

C8000 - D8000

The board allows you to terminate each of the two CAN ports separately by means of DIP switches at the back panel of the board. Both CAN ports must be terminated before you can use the loopback model provided to test the board and drivers. Refer to the Softing user manual on how to set the DIP switches.

Interrupt line

Select an interrupt line from the list.

External Websites

- www.can-cia.org
- company.softing.com/en

Softing CAN-AC2-104 with Philips SJA1000 FIFO Write

Softing CAN-AC2-104 with Philips SJA1000 FIFO Write block

Library

Simulink Real-Time Library for CAN

Description

The **FIFO Write** driver block writes CAN messages into the transmit FIFO. The firmware running in FIFO mode then processes the information in the transmit FIFO and finally puts the constructed CAN messages onto the bus. This block dynamically detects the data type and signal size of the signal that you connect to the input port.

If you use the `CAN_MESSAGE` data type:

If the block input is a `CAN_MESSAGE` data type, use **CAN Pack** blocks to pack individual signals into a CAN message. If you use **CAN Pack** blocks to prepare each message, the **FIFO Write** block reads the `CAN_MESSAGE` data. To combine several messages into a vector of `CAN_MESSAGE` data that the **FIFO Write** block sends, use a **Mux** block. Use the **Port (if input is CAN_MESSAGE)** parameter to select the port to which to send the `CAN_MESSAGE` data.

Tip To prepare a remote frame, use the **CAN Pack** block with the **Remote frame** check box selected. To request the current value, send the remote frame to the responding subsystem.

If you use the double data type (legacy):

If the block input consists of double values in a matrix, the block has one input port of type double. At this port, you must provide the elements required to construct valid CAN messages to be written into the transmit FIFO. For each CAN message, five elements have to be passed:

Port

The value can be either 1 (port 1) or 2 (port 2) and defines at which port the CAN message is sent from.

Identifier

Identifier of the CAN message to be sent. If it is a standard CAN message, the valid range is 0 to 2047. If extended, the range is 0 to $2^{29}-1$.

Identifier type

The value can be either 0 (standard identifier range) or 1 (extended identifier range) and defines the identifier type of the outgoing CAN message.

Data frame size

The value can be in the range of 0 to 8 and defines the data frame size in bytes of the outgoing CAN message

Data

Data for the data frame itself. Use the **CAN Bit-Packing** block to construct the data as double values in a matrix.

Because this information can be dynamically changed in FIFO mode during real-time application execution, the information is provided at the block input instead of using the block parameters. To transmit more than one CAN message per block instance, use a matrix signal as a container.

The dimension of the matrix signal entering the block must be $n*5$, where n is the number of CAN messages to be sent by this block instance. Therefore, each row of the matrix signal defines one CAN message and each row combines the five elements of information defined above (in this order).

For examples of constructing the matrix signal for the **FIFO Write** block, see “CAN FIFO Loopback Tests” on page 6-11.

For certain models, you might make the writing of a CAN message into the transmit FIFO dependent on the model dynamics. For this, the matrix signal can also be of dimension $n*6$ instead of $n*5$. In this case, the sixth column defines whether the corresponding CAN message is written into the transmit FIFO (value 1) or not (value 0).

Block Parameters

Board

Defines the board used to send the CAN messages defined by this block instance. For more information about the meaning of the board number, see the **Setup** driver block. If just one board is present in the target system, select board number 1.

Show input count port

Select this check box to track the number of inputs to the block and add a second input port, *N*, to the block. If this port value exceeds the size of the input vector of CAN_MESSAGE messages, the block limits the transfer to the size of the input vector. If this port value is smaller than the CAN_MESSAGE input vector size, the block transfers data up to the size of this port value. For example, assume an input of 10*5 matrix. If you then input a 5 to input port *N*, the block sends only the first five messages. In an n*6 matrix, the last entry in the row is still the individual message enabled, but the block checks only messages up to n. If the input is a matrix of doubles, the block ignores the value of the **Port** parameter. The block considers the port as part of the data.

If this check box is cleared, the block sends all elements of the input vector.

Port (if input is CAN_MESSAGE)

If the message is a CAN_MESSAGE data type, from the list, select 1 or 2 for the port to send the message through. The block sends a message to a single CAN port. If you want to send messages to different ports in a model, use multiple FIFO Write blocks. This input port is the first one on the block. Its input is a vector or single CAN_MESSAGE message.

If the message consists of double values in a matrix, changing this parameter does not change block behavior. You specify the port number in the CAN message. A single FIFO Write block can send messages through both ports.

Show status output port

Selecting this check box lets you enable the status output port. If the box is cleared (disabled), the block does not have an output port. If enabled, a port is shown. The signal leaving the block is a vector of type CAN_MESSAGE or double depending on which data type you are using for your messages. The number of elements depends on the signal dimension of the block input port. There is one element for each CAN message written into the transmit FIFO and the value is identical to the return argument of function CANPC_send_data, described in the Softing user manual. Refer to that manual for more information. The function return codes are:

Code	Description
0	Function executed without detecting an error.

Code	Description
- 1	Function encountered an error.
- 4	Timeout firmware communication.
- 99	Board not initialized.

Sample time

Defines the sample time at which the **FIFO Write** block is executed during a real-time application run.

You can use as many instances of the **FIFO Write** block in the model as required. For example, by using two instances of the block with different sample times, you can send CAN messages out at different rates. Or you can use multiple instances to structure your model more efficiently.

External Websites

- www.can-cia.org
- company.softing.com/en

Softing CAN-AC2-104 with Philips SJA1000 FIFO Read

Softing CAN-AC2-104 with Philips SJA1000 FIFO Read block

Library

Simulink Real-Time Library for CAN

Description

The **FIFO Read** driver block reads CAN messages from the receive FIFO. The firmware running in FIFO mode puts received events (CAN messages) into the receive FIFO. From here, the FIFO Read driver reads the events out. The receive FIFO can store up to 127 events (messages). If it is full and a **FIFO Read** driver block does not attempt to read the stored events, new incoming events are lost. This is reflected by increments to the lost message counter. You can use the **FIFO Read RCV Level** driver block to check for this condition and take action (for example, by stopping the execution or resetting the receive FIFO).

If you choose `CAN_MESSAGE` data type as the output, use **CAN Unpack** blocks to unpack individual signals from a CAN message.

Tip To process a remote frame, use the **CAN Unpack** block with the **Output remote** check box selected to enable the Remote port. When the Remote port becomes `true`, send the current value to the requesting subsystem.

If you choose matrix as the output data type, the **FIFO Read** driver block has one output port of type double. The signal of this port is a matrix of size $m \times 6$, where m is the FIFO read depth defined in the block's dialog box (see below). For example, if the FIFO read depth is 5, the matrix signal of port 1 has size 5×6 . Therefore, there is one row for each event read from the receive FIFO (no new message is considered as an event as well). For examples of extracting data from the matrix signal, see “CAN FIFO Loopback Tests” on page 6-11.

If you choose output as double values in a matrix, each row with its six elements contains the information defining a CAN message:

Port

The value is either 1 (port 1) or 2 (port 2) and reports the port at which the CAN message was received.

Identifier

Identifier of the CAN message being received. If it is a standard CAN message, the range is 0 to 2047. If the CAN message is extended, the range is 0 to $2^{29}-1$.

Event type

Defines the type of event read from the receive FIFO. The following values are defined from the Softing user manual:

Events	Description
16	No new event.
17	Standard data frame received.
18	Standard remote frame received.
19	Transmission of a standard data frame is confirmed.
20	
21	Change of bus state.
22	
23	
24	Transmission of a standard remote frame is confirmed.
25	Extended data frame received.
26	Transmission of an extended data frame is confirmed.
27	Transmission of an extended remote frame is confirmed.
28	Extended remote frame received.
29	
30	
31	Error frame detected.

Data frame size

If a data frame has been received, the length of the data in bytes is reported by this element. Possible values are 0 to 8.

Timestamp

Reports the time at which the event was received. The resolution of the timestamp counter is 1µs.

Data

Data of the data frame itself. It is returned as a CAN_MESSAGE or double value (8 bytes) depending on which data type you are using for your messages. Use the CAN Pack to extract data from the CAN_MESSAGE data. Use the CAN Bit-Unpacking block to extract the data from the double value.

Block Parameters

Board

Defines the board to use to send the CAN messages defined by this block instance. For more information about the meaning of the board number, see the Setup driver block. If just one board is present in the target system, select board number 1.

Output format

From the list, select:

- Matrix of doubles (legacy)

Formats messages as double values in a matrix. See “Description” on page 7-10 for details on this message format.

- Vector of CAN_MESSAGE plus count

Formats messages as vectors of CAN_MESSAGE structures.

Selecting this option enables the **Port** parameter. It also creates an *N* output port that contains the number of valid entries in the CAN_MESSAGE data vector. The block interprets the **FIFO read depth** value as the size of the vector. The block outputs up to **FIFO read depth** number of messages. For example, if you enter a read depth of 3, but the receive FIFO has only two messages, the output vector has only two messages. The “CAN I/O FIFO Mode - Simple Use Case (with CAN_MESSAGE)” example illustrates the use of this parameter.

- Function call for each CAN_MESSAGE

Formats messages as vectors of CAN_MESSAGE structures.

Selecting this option enables the **Port** parameter. It also creates a function-call output (f()) output port. This port contains a function-call for a single CAN_MESSAGE data element. The block repeats the function-call for each message from the FIFO, up to the value of **FIFO read depth**. You input this function-call output into a function-call subsystem. The “CAN I/O FIFO Mode - Simple Use Case (with CAN_MESSAGE and Function Call Output)” example illustrates the use of this parameter.

Port

CAN_MESSAGE only. From the list, select 1 or 2 for the input port. The block reads the message from that FIFO (1 or 2). Its output is a vector of CAN_MESSAGE messages. If you want to read from both ports, use two FIFO Read blocks, one for each port. Selecting Vector of CAN_MESSAGE plus count for **Output format** enables this parameter.

Selecting Matrix of doubles (legacy) or Function call for each CAN_MESSAGE for the **Output format** parameter disables this parameter. The block ignores the port. In this case, the block reads from both ports and records the port for each message in the output matrix.

FIFO read depth

Defines the number of receive FIFO read attempts. Each time the block is executed, it reads this fixed number of events (CAN messages), which leads to a deterministic time behavior independent of the number of events currently stored in the receive FIFO. The read depth (m) also defines the size of the matrix signal (m*6) leaving the first output port. If an event is not currently stored in the receive FIFO, the FIFO is read anyway, but the event type is reported as 0 (no new event).

Show status output port

Lets you enable the status output port (S). If the box is cleared (disabled), the block has one output port for events. If enabled, a second port is shown. The signal leaving that port is a vector of doubles, with two elements:

```
[Number of lost messages (events), Bus state]
```

The first element returns the current value of the lost messages counter. The receive FIFO can store up to 127 events. If the receive FIFO is not regularly accessed for reading events, the FIFO is filled and the lost messages counter starts to increment.

This is an indicator that events (messages) will be unavoidably lost. The second element returns the current bus state. Possible values are

Code	Description
3	Error active
4	Error passive
5	Bus off

Sample time

Defines the sample time at which the **FIFO Read** block is executed during a real-time application run.

Only use one instance of this block per physical CAN board in your model. Otherwise you may get unwanted behavior when one instance reads events while the events are being processed by blocks connected to the other, second instance.

External Websites

- www.can-cia.org
- company.softing.com/en

Softing CAN-AC2-104 with Philips SJA1000 FIFO Read XMT Level

Softing CAN-AC2-104 with Philips SJA1000 FIFO Read XMT Level block

Library

Simulink Real-Time Library for CAN

Description

The **FIFO Read XMT Level** driver block reads the current number of CAN messages stored in the transmit FIFO to be processed by the firmware. The transmit FIFO can store up to 31 messages. If it is full and a **FIFO Write** driver block tries to add another message to the transmit FIFO, the passed messages are lost. You can use this driver block to check for this condition and take action. For example, you can stop the execution or wait for the transmit FIFO to empty.

The block has a single output port of type double, returning a scalar value containing the current transmit FIFO level (number of messages to be processed).

Block Parameters

Board

Defines the board to access to read the current transmit FIFO level. For more information about the meaning of the board number, see the **Setup** driver block. If just one board is present in the target system, select board number 1.

Sample time

Defines the sample time at which the **FIFO Read XMT Level** driver block is executed during a real-time application run.

External Websites

- www.can-cia.org

- company.softing.com/en

Softing CAN-AC2-104 with Philips SJA1000 FIFO Reset XMT

Softing CAN-AC2-104 with Philips SJA1000 FIFO Reset XMT block

Library

Simulink Real-Time Library for CAN

Description

The FIFO Reset XMT driver block resets the transmit FIFO. This deletes the messages currently stored in the transmit FIFO and resets the level counter to 0. For example, you can use this driver block to reset the transmit FIFO after detecting a fault condition.

The block has a single input port of type double. If a scalar value of 1 is passed, the transmit FIFO is reset; if 0 is passed, nothing is done.

Block Parameters

Board

Defines the board to access to reset the transmit FIFO. For more information about the meaning of the board number, see the Setup driver block. If just one board is present in the target system, select board number 1.

Sample time

Defines the sample time at which the FIFO Reset XMT driver block is executed during a real-time application run.

External Websites

- www.can-cia.org
- company.softing.com/en

Softing CAN-AC2-104 with Philips SJA1000 FIFO Read RCV Level

Softing CAN-AC2-104 with Philips SJA1000 FIFO Read RCV Level block

Library

Simulink Real-Time Library for CAN

Description

The `FIFO Read RCV Level` driver block reads the current number of CAN messages stored in the receive FIFO. The receive FIFO can store up to 127 events (messages). If it is full and a `FIFO Read` driver block does not attempt to read the stored events, new incoming events are lost. This is reflected by increments to the lost message counter. You can use this driver block to check for this condition and take action (for example, like stopping the execution or resetting the receive FIFO).

The block has a single output port of type double, returning a scalar value containing the current receive FIFO level (number of messages to be processed).

Block Parameters

Board

Defines the board to access to read the current receive FIFO level. For more information about the meaning of the board number, see the `Setup` driver block. If just one board is present in the target system, select board number 1.

Sample time

Defines the sample time at which the `FIFO Read RCV Level` driver block is executed during a real-time application run.

External Websites

- www.can-cia.org

- company.softing.com/en

Softing CAN-AC2-104 with Philips SJA1000 FIFO Reset RCV

Softing CAN-AC2-104 with Philips SJA1000 FIFO Reset RCV block

Library

Simulink Real-Time Library for CAN

Description

The FIFO Reset RCV driver block resets the receive FIFO. This deletes the messages currently stored in the receive FIFO and resets the level counter to 0. For example, you can use this driver block to reset the receive FIFO after detecting a fault condition.

The block has a single input port of type double. If a scalar value of 1 is passed, the transmit FIFO is reset; if 0 is passed nothing is done.

Block Parameters

Board

Defines the board to access to reset the receive FIFO. For more information about the meaning of the board number, see the **Setup** driver block. If just one board is present in the target system, select board number 1.

Sample time

Defines the sample time at which the FIFO Reset RCV driver block is executed during a real-time application run.

External Websites

- www.can-cia.org
- company.softing.com/en

Model-Based Ethernet Communications Support

Model-Based Ethernet Communications

In this section...

“What Is Model-Based Ethernet Communications?” on page 8-2

“Ethernet Hardware” on page 8-2

“PCI Bus and Slot Numbers” on page 8-3

“MAC Addresses” on page 8-3

“Network Buffer Pointers” on page 8-4

“Filter Type and Filter Address Blocks” on page 8-4

“Execution Priority” on page 8-4

“Simulink Real-Time Ethernet Block Library” on page 8-4

What Is Model-Based Ethernet Communications?

The Simulink Real-Time software supports communication from the target computer to other systems or devices using raw Ethernet (Ethernet packets). Raw Ethernet is a direct method to send and receive packets with the real-time application using the Ethernet protocol. To transfer data using Ethernet packets, you must manually create Ethernet frames. This topic assumes that you are knowledgeable about the IEEE[®] 802.3 standard.

By itself, raw Ethernet does not implement the TCP/IP or UDP standards. For information about modeling protocols built upon raw Ethernet, see:

- “Real-Time UDP”
- “UDP”

Ethernet Hardware

Before you start, provide a dedicated Ethernet card on your target computer. A dedicated Ethernet card is to be used only for model-based Ethernet communications and not for communication between the development and target computers. This requirement means that your target computer must have at least two Ethernet cards, one for the link between the development and target computers, and one for model-based Ethernet communication. The Simulink Real-Time model-based Ethernet communication blocks support selected members of the following Intel (Vendor ID 0x8086) chip families:

- Intel 8255X
- Intel Gigabit

PCI Bus and Slot Numbers

To use the model-based Ethernet blocks, specify the PCI bus and slot number of the dedicated Ethernet card in the **Real-Time Ethernet Configuration** block. To identify which Ethernet card is available:

- 1 Boot the target computer with which you want to perform model-based Ethernet communications.
- 2 Examine the startup screen on the target computer. Note the PCI bus and slot information on the bottom right of the status window. This represents the Ethernet card installed on the target computer for dedicated communication between the development and target computers.
- 3 In the MATLAB Command Window, type

```
tg = slrt;  
getPCIInfo(tg, 'ethernet')
```

This command determines which Ethernet cards are installed in the target computer.

- 4 In the list, find the Ethernet card with a bus and slot different from that displayed on the target computer monitor.
- 5 Note the PCI bus and slot of the free Ethernet card. This is the card you can use for model-based Ethernet communications.

MAC Addresses

A number of the Ethernet blocks require you to enter MAC addresses. The MAC address must be vector-based. To obtain the vector-based version of a MAC address, use the `macaddr` command. This command converts a string-based MAC address to a vector-based one. For example:

```
macaddr('01:23:45:67:89:ab')
```

```
[1 35 69 103 137 171]
```

When an Ethernet block requires a MAC address, you can enter either of the following in the address field:

- Command `macaddr('MAC address string')`, for example:
`macaddr('01:23:45:67:89:ab')`
- Vector-based output from the `macaddr` command, for example:
`[1 35 69 103 137 171]`

Network Buffer Pointers

The Simulink Real-Time Ethernet block library uses pointers to refer to network buffers. Blocks can pass pointers to these buffers as single `uint32` pointers. They can also refer to a chain of network buffer packets.

Filter Type and Filter Address Blocks

The `Filter Type` and `Filter Address` blocks accept a chain of network buffers as input. Based on the criteria specified in the masks of these blocks, the drivers parse each buffer on the chain and either pass the packets through the port or drop the packets. When using these blocks, create your models with filter blocks to pass data only from expected sources.

Execution Priority

The raw Ethernet blocks have the following execution priority, from first to last:

- 1 Real-Time Ethernet Configuration
- 2 The remaining raw Ethernet and network buffer library blocks

Simulink Real-Time Ethernet Block Library

To access the Simulink Real-Time Ethernet library blocks, in the Simulink Real-Time block library, double-click Ethernet. The Simulink Real-Time Ethernet library is displayed.

The Simulink Real-Time Ethernet library contains commonly used Ethernet blocks at the top level of the library. Use these blocks to create your models.

The Ethernet library also has a sublibrary, `Network Buffers`, which contains blocks specific to the management of Ethernet network buffers. The blocks in this sublibrary are

core blocks that you might want to use to create other subsystems. However, the top-level Ethernet blocks provide enough functionality for model-based Ethernet communications.

Related Examples

- “Real-Time Transmit and Receive over Ethernet”
- “Filtering on MAC Address”
- “Filtering on EtherType”

Ethernet Blocks

Real-Time Ethernet Configuration
Create Ethernet Packet
Ethernet Init
Ethernet Rx
Ethernet Tx
Extract Ethernet Packet
Filter Address
Filter Type
Header Extract

Real-Time Ethernet Configuration

Configure network interface for real-time raw Ethernet communication

Library

Simulink Real-Time Library for Ethernet

Description

Use the **Real-Time Ethernet Configuration** block to initialize the network and network buffers.

Block Parameters

This block has three tabs, **Device**, **Addressing**, and **Advanced**.

Device

Device ID

From the list, select a unique integer to identify the Ethernet board. Use this ID to associate the other Ethernet blocks with this board.

Driver

Identifies the driver for each chip family supported. Possible values are **Intel 8255X** and **Intel Gigabit**.

PCI bus

Enter the PCI bus number for the Ethernet card.

PCI slot

Enter the PCI slot number for the Ethernet card.

Sample time

Enter the base sample time or a multiple of the base sample time (-1 means sample time is inherited).

Addressing

Address source

From the list, select:

- **EEPROM**

Allow the block to get the Ethernet card MAC address that is built into the Ethernet card.

- **Specify**

Enable the **MAC** parameter so that you can manually enter a MAC address for the Ethernet card.

MAC

Enter the MAC address for the Ethernet card.

Enable this parameter by selecting **Specify** for the **Address source** parameter.

Rx promiscuous

Select this check box to direct the model to receive all packets regardless of their destination address.

Multicast address list

Enter a list of multicast address vectors as a cell array. By default, this parameter contains an empty cell array. The **Ethernet Rx** block uses these addresses in addition to the broadcast address and unicast address.

Advanced

You do not normally need to modify the values of the parameters in this tab. Changing the values of these parameters can change the behavior of your system.

Rx bad frames

Select this check box to direct the model to receive all packets, including erroneous ones (such as CRC error, alignment error, and so forth).

Rx short frames

Select this check box to direct the model to receive all packets, including frames that are less than 64 bytes in length.

Note: The Intel Gigabit Ethernet controller does not distinguish between bad packets and short packets. Therefore, checking either **Rx Bad Frames** or **Rx Short Frames** has the same results for **Driver** type Intel Gigabit.

Max MTU

Specify a maximum transmission unit number (MTU). This parameter allows you to specify a smaller maximum transmission unit number. The default is 1518.

Tx threshold

Enter a value to control when the Ethernet device will begin to perform direct memory access (DMA) on packets from memory. The default is 224.

Note:

- This parameter only applies for **Driver** type Intel 8255X.
 - Before you change this parameter, see *Intel 8255x 10/100 Mbps Ethernet Controller Family — Open Source Software Developer Manual*.
-

Tx buffers

Enter the maximum number of buffers to hold in the queue before the driver is to drop new transmit requests. The default is 128.

Rx buffers

Enter the maximum number of buffers to hold in the queue before the driver is to drop new receive packets. The default is 64.

Note: For both **Tx Buffers** and **Rx Buffers**, the number of buffers must be a multiple of 8.

Display tuning information

Select this check box to enable a display of statistical data collected during the run of the model.

External Websites

- www.iso.org

Create Ethernet Packet

Create Ethernet Packet based on the MAC address and EtherType provided

Library

Simulink Real-Time Library for Ethernet

Description

Use the `Create Ethernet Packet` block to create the Ethernet packets that you want to transfer.

Block Parameters

Destination MAC

Enter the MAC address of the target computer to receive the data.

EtherType (use 0 for length)

Enter a value to represent either the EtherType or the length that the Ethernet frame is to transfer.

- EtherType — If you are working with Ethernet packets that use EtherType values, enter a valid EtherType value to specify which prototype the Ethernet frame will transfer.
- Ethernet length — If you are working with Ethernet packets that use Ethernet lengths, enter 0.

External Websites

- www.iso.org

Ethernet Init

Initialize network card for real-time raw Ethernet communication

Library

Simulink Real-Time Library for Ethernet

Description

Use the `Ethernet Init` block to initialize the Ethernet communication channel.

You must use an `Ethernet Init` block for each Ethernet board.

Note: The `Ethernet Init` and `Buffer Mngmt` blocks are combined in the `Real-Time Ethernet Configuration` block. Use this block for new development.

Block Parameters

This block has three tabs, **Device**, **Addressing**, and **Advanced**.

Device

Device ID

From the list, select a unique integer to identify the Ethernet board. Use this ID to associate the other Ethernet blocks with this board.

Driver

Identifies the driver for each chip family supported. Possible values are `Intel 8255X` and `Intel Gigabit`.

PCI bus

Enter the PCI bus number for the Ethernet card.

PCI slot

Enter the PCI slot number for the Ethernet card.

Sample time

Enter the base sample time or a multiple of the base sample time (- 1 means sample time is inherited).

Addressing

Address source

From the list, select:

- **EEPROM**

Allow the block to get the Ethernet card MAC address that is built into the Ethernet card.

- **Specify**

Enable the **MAC** parameter so that you can manually enter a MAC address for the Ethernet card.

MAC

Enter the MAC address for the Ethernet card.

Enable this parameter by selecting **Specify** for the **Address source** parameter.

Rx promiscuous

Select this check box to direct the model to receive all packets regardless of their destination address.

Multicast address list

Enter a list of multicast address vectors as a cell array. By default, this parameter contains an empty cell array. The **Ethernet Rx** block uses these addresses in addition to the broadcast address and unicast address.

Advanced

You do not normally need to modify the values of the parameters in this tab. Changing the values of these parameters can change the behavior of your system.

Rx bad frames

Select this check box to direct the model to receive all packets, including erroneous ones (such as CRC error, alignment error, and so forth).

Rx short frames

Select this check box to direct the model to receive all packets, including frames that are less than 64 bytes in length.

Note: The Intel Gigabit Ethernet controller does not distinguish between bad packets and short packets. Therefore, checking either **Rx Bad Frames** or **Rx Short Frames** has the same results for **Driver** type Intel Gigabit.

Max MTU

Specify a maximum transmission unit number (MTU). This parameter allows you to specify a smaller maximum transmission unit number. The default is 1518.

Tx threshold

Enter a value to control when the Ethernet device will begin to perform direct memory access (DMA) on packets from memory. The default is 224.

Note:

- This parameter only applies for **Driver** type Intel 8255X.
 - Before you change this parameter, see *Intel 8255x 10/100 Mbps Ethernet Controller Family — Open Source Software Developer Manual*.
-

Tx buffers

Enter the maximum number of buffers to hold in the queue before the driver is to drop new transmit requests. The default is 128.

Rx buffers

Enter the maximum number of buffers to hold in the queue before the driver is to drop new receive packets. The default is 64.

Note: For both **Tx Buffers** and **Rx Buffers**, the number of buffers must be a multiple of 8.

Display tuning information

Select this check box to enable a display of statistical data collected during the run of the model.

External Websites

- www.iso.org

Ethernet Rx

Receive data over Ethernet network

Library

Simulink Real-Time Library for Ethernet

Description

Use the **Ethernet Rx** block to receive Ethernet packets and to filter on the received packets. You can filter packets by **EtherType** or length. You can use multiple **Ethernet Rx** blocks with the same device ID. However, you must configure each block to filter a unique set of packets.

Block Parameters

This block has two tabs, **Rx** and **Filter**.

Rx

Device ID

From the list, select a unique number to identify the Ethernet board. Select the same **Device ID** as the one you selected for the **Real-Time Ethernet Configuration** block.

Sample time

Enter the base sample time or a multiple of the base sample time (-1 means sample time is inherited).

Filter

Filter criteria

From the list, select how you want to filter on **EtherTypes** (Ethernet II framing standard) or **Ethernet lengths** (IEEE 802.3 framing standard).

- Receive all unmatched types [0 to 65535]

Select this option to output all unmatched packets, both Ethernet II framing and IEEE 802.3 framing standards.

- Receive unmatched lengths [0 to 1500]

Select this option to output all packets with IEEE 802.3 framing standard.

- Receive unmatched EtherTypes [150 to 65535]

Select this option to output all output packets with Ethernet II framing standard.

- Specify types to match

Select this option to enter your own criteria of the EtherTypes to output. This option enables the **Receive these types (vector of types 0–65535)** parameter.

Receive these types (vector of types 0–65535)

Enter a vector of EtherTypes that you want to enable to output, for example [hex2dec('0000')].

This field appears only if you select **Specify types to match** for the **Filter criteria** parameter.

External Websites

- www.iso.org

Ethernet Tx

Transmit data over Ethernet network

Library

Simulink Real-Time Library for Ethernet

Description

Use the Ethernet Tx block to send network packets.

Block Parameters

Device ID

From the list, select a unique number to identify the Ethernet board. Select the same **Device ID** as the one you selected for the **Real-Time Ethernet Configuration** block.

Sample time

Enter the base sample time or a multiple of the base sample time (- 1 means sample time is inherited).

External Websites

- www.iso.org

Extract Ethernet Packet

Extract data from Ethernet packet

Library

Simulink Real-Time Library for Ethernet

Description

Use the Extract Ethernet Packet block to extract data from an Ethernet packet.

Block Parameters

Data Size

Enter the data size (in bytes) for the data you want to extract from an Ethernet packet.

External Websites

- www.iso.org

Filter Address

Filter Ethernet packets based on MAC address

Library

Simulink Real-Time Library for Ethernet

Description

Use the **Filter Address** block to filter network buffer packets, using their MAC addresses as the sort criteria. See “Filter Type and Filter Address Blocks” on page 8-4 for cautions on setting the parameters for this block.

Block Parameters

MAC Address

Enter a cell array of the MAC address for the filter.

Drop non-matches

Select this check box to discard packets whose MAC addresses do not match those entered in the parameter **MAC Address**.

Clear this check box to direct the block to output packets whose MAC addresses do not match those entered in the **MAC Address** parameter.

Filter on destination address

Clear this check box (default) to direct the block to filter addresses for the source address.

Select this check box to direct the block to filter addresses for the destination address.

External Websites

- www.iso.org

Filter Type

Filter Ethernet packets based on EtherType

Library

Simulink Real-Time Library for Ethernet

Description

Use the **Filter Type** block to filter network buffer packets, using their EtherType values as the sort criteria. See “Filter Type and Filter Address Blocks” on page 8-4 for cautions on setting the parameters for this block.

Block Parameters

Match Length (1-1500)

Select this check box to match packets whose EtherType values fall within the range 1 to 1500.

EtherType

Enter a space delimited list of EtherTypes that you want to filter upon.

Drop non-matches

Clear this check box (default) to direct the block to output packets whose EtherTypes or Ethernet lengths do not match those entered in the parameter **EtherType**.

Select this check box to direct the block to discard packets whose EtherTypes or Ethernet lengths do not match those entered in the parameter **EtherType**.

External Websites

- www.iso.org

Header Extract

Extract header data from Ethernet packet

Library

Simulink Real-Time Library for Ethernet

Description

Use the Header Extract block to extract the header data of network buffer packets.

External Websites

- www.iso.org

Network Buffer Library for Model-Based Ethernet Communications Support

Network Buffer Blocks

The Ethernet library includes a sublibrary, **Network Buffers**, that contains blocks for managing Ethernet network buffers. The blocks in this sublibrary are core blocks that you can use to create other subsystems.

The Ethernet drivers use a set of buffers, *Ethernet network buffers*, that it uses to store data that is sent and received over the network. The block organizes these buffers into several pools, each with different values of maximum data size. The buffers include information about the data itself. The block allocates the buffer pools during model initialization and does not change the buffer pools during model run time. When the block sends, receives, or processes data, it allocates a buffer. When the operation is done, it frees the buffer.

You can control the number of buffers allocated for each allowable value of data size by using the **Buffer Mngmt** block parameter **Buffer pool sizes**. Allocate enough buffers for the maximum number of data packets that you anticipate receiving, sending, or processing at one time. You can send and receive more data by allocating many more buffers. However, each allocation reserves more memory, which you cannot then use for other purposes. Running out of buffers means that no data can be sent and received until the block frees allocated buffers.

Monitor the buffer pool statistics at run time to find the optimal values that an application requires. To monitor the buffer pool statistics, select the **Display tuning information** check box in the **Buffer Mngmt** block parameters dialog box.

See Also

Buffer Mngmt

Network Buffer Library Blocks

Buffer Mngmt
Chain Size
Compose
Extract
Link
Manage
Merge
Split
Unlink

Buffer Mngmt

Initialize network buffer pools

Library

Simulink Real-Time Library for Ethernet

Description

To initialize network buffers, use the `Buffer Mngmt` block.

Block Parameters

This block has two tabs, **Main** and **Advanced**.

Main

Sample time

Enter the base sample time or a multiple of the base sample time (- 1 means sample time is inherited).

Advanced

Modify the values of the parameters in this tab only if you have a thorough understanding of the Ethernet protocol. Changing the values of these parameters can change the behavior of your system.

Buffer pool sizes (256, 512, 1024, 2048)

Enter a vector of the number of buffers for each pool size (256, 512, 1024, or 2048).

Display tuning information

Select this check box to enable a display of statistical data collected during the run of the model.

More About

- “Network Buffer Blocks” on page 10-2

External Websites

- www.iso.org

Chain Size

Determine the number of network buffers in the chain

Library

Simulink Real-Time Library for Ethernet

Description

To determine the number of buffers that are on the chain, use the `Chain Size` block.

External Websites

- www.iso.org

Compose

Create a network buffer from raw input data

Library

Simulink Real-Time Library for Ethernet

Description

To create a network buffer, use the **Compose** block. This block creates a pointer to a network buffer.

External Websites

- www.iso.org

Extract

Extract raw data from network buffer

Library

Simulink Real-Time Library for Ethernet

Description

To extract network buffer packets, use the `Extract` block.

Block Parameters

Packet size (-1: inherit)

Enter the packet size for the network buffer packet to extract. Enter -1 (default) to inherit the packet size.

External Websites

- www.iso.org

Link

Link vector of network buffers into a chain

Library

Simulink Real-Time Library for Ethernet

Description

To convert a vector of network buffer signals into a linked list of signals, use the `Link` block.

External Websites

- www.iso.org

Manage

Output or buffer packets as indicated by the parameters

Library

Simulink Real-Time Library for Ethernet

Description

Output or buffer packets as indicated by the parameters.

Block Parameters

Chain size

Specify the queuing (output) behavior of the block as packets are received.

Value	Description
inf	Output all packets. No queuing occurs.
0	Delete all packets, no packets pass through.
Positive number, <i>C</i>	Pass through the first <i>C</i> packets
Negative number, <i>C</i>	Pass through the last <i>C</i> packets

Buffer size

Specify the buffering behavior of the block as packets are received.

Value	Description
inf	Buffer all remaining packets. Delete no packets.
0	Do not buffer packets. Delete all remaining packets.
Positive number, <i>B</i>	Buffer the remaining first <i>B</i> packets.

Value	Description
Negative number, B	Buffer the remaining last B packets.

Threshold

Enter a minimum threshold before which this block begins to output buffers.

Value	Description
0	Specifies no threshold.
Negative number, T	Delay passing buffer packets until T packets are buffered.
Positive number, T	Passes buffer packets if T packets are buffered.

External Websites

- www.iso.org

Merge

Merge the incoming network buffer chains into one

Library

Simulink Real-Time Library for Ethernet

Description

To combine signal pointers to a linked list, use the **Merge** block.

Block Parameters

Number of inputs

Enter the number of network buffer signal pointers to combine into a linked list.

External Websites

- www.iso.org

Split

Split a network buffer chain

Library

Simulink Real-Time Library for Ethernet

Description

To separate a linked list of buffer pointers into separate individual pointers, use the **Split** block.

Block Parameters

Number of outputs

Enter the number of pointers the input linked list should be separated into.

- If the number of buffers is the same as this value, this block splits them and outputs them in the order they appear in the vector, or in reverse order (depending on the setting of the **Split in reverse order** parameter).
- If the number of buffers is less than **Number of outputs**, the block outputs zeros (0s) for the extra output ports.
- If the number of buffers is greater than **Number of outputs**, the block either deletes the extra buffers, or chains the remaining buffers together (depending on the setting of the **Allow chaining for last signal** parameter).

Split in reverse order

Select this check box to split out the network buffers in the reverse order in which they are received.

Allow chaining for last signal

Select this check box to chain together remaining network buffers. There might be remaining buffers if the incoming linked list contains more buffers than the number in **Number of outputs**.

Clear this check box to delete the remaining buffers.

External Websites

- www.iso.org

Unlink

Unlink a chain into a vector of network buffers

Library

Simulink Real-Time Library for Ethernet

Description

To convert a linked list of signals into a vector of network buffer signal, use the `Unlink` block.

Block Parameters

Vector length (-1: inherit)

Enter the number of signals in the linked list of signals that you want to separate.
Enter -1 (default) to inherit the vector length.

External Websites

- www.iso.org

Model-Based EtherCAT Communications Support

- “Modeling EtherCAT Networks” on page 12-2
- “Install EtherCAT Network and Configuration Software” on page 12-6
- “EtherCAT Installation and Setup Requirements” on page 12-7
- “Configure EtherCAT Network” on page 12-8
- “Install EtherCAT Network for Execution” on page 12-15
- “Configure EtherCAT Master Node Model” on page 12-16
- “Fixed-Step Size Derivation” on page 12-21
- “EtherCAT Protocol Mapping” on page 12-22
- “EtherCAT Configurator Component Mapping” on page 12-23
- “Ethernet Chip Sets Compatible with EtherCAT” on page 12-24
- “EtherCAT Data Types” on page 12-27
- “EtherCAT Init Block Error Values” on page 12-28
- “EtherCAT Init Block DC Error Values” on page 12-30

Modeling EtherCAT Networks

Ethernet for Control Automation (EtherCAT) is an open Ethernet network protocol for real-time distributed control, for example for automotive and industrial systems. The EtherCAT protocol provides:

- Deterministic and fast cycle times
- Inexpensive I/O module cost

EtherCAT networks consist of one master node and several slave nodes. The Simulink Real-Time EtherCAT sublibrary supports only the master node of an EtherCAT network. You cannot emulate slave nodes using the blocks in the EtherCAT sublibrary. However, you can use these blocks to prototype multiple EtherCAT networks with multiple Ethernet cards.

You model an EtherCAT network using one of the third-party EtherCAT configurators: the Beckhoff® ET9000, the Beckhoff TwinCAT®, or the Acontis EC-Engineer. To map the network model into a Simulink Real-Time model, become familiar with the following mappings:

- “EtherCAT Protocol Mapping” on page 12-22
- “EtherCAT Configurator Component Mapping” on page 12-23

Blocks and Tasks

At a minimum, each EtherCAT model must contain an `EtherCAT Init` block. The `EtherCAT Init` block contains a reference to an EtherCAT configuration. The file describes the network, including the device variables of the network. It also contains information identifying the Ethernet card for the EtherCAT network that the software accesses.

If you generate the configuration file using the Beckhoff ET9000 or the Beckhoff TwinCAT software, use the software to create at least one cyclic input/output task. Link this task to at least one input channel and one output channel on each slave device. If you generate the file using Acontis EC-Engineer, the software creates one default task linked to all slave device input/output channels.

When you know the input/output task rates, set the **Fixed-step size** in the Configuration Parameters dialog box to a value consistent with the following constraints:

- The task rates of all EtherCAT slave devices.
- The sample times of all other blocks in the Simulink model.

When you know the device variables that you are using in your model, add an **EtherCAT PDO Receive** or **EtherCAT PDO Transmit** block for every EtherCAT device variable. When you add these blocks to the model, the block obtains the list of device variables from the configuration file in the **EtherCAT Init** block. When you specify a device variable in the block dialog box, the software updates the block information with device variable information from the configuration file.

To transmit CANopen over EtherCAT (CoE) information through your network, add **SDO Upload** and **SDO Download** blocks to your model. The SDO blocks come in two types, synchronous and asynchronous. From the EtherCAT perspective, there is little difference in behavior of these types. The difference arises during the execution of the real-time application. The **Sync SDO** blocks halt execution while they wait for a response. The **Async SDO** blocks continue executing and poll the I/O module for a response. To avoid a CPU overload, use a slower execution rate for the SDO blocks than for the PDO blocks.

To track the state of the network or force the network into a particular state, add an **EtherCAT Get State** or **EtherCAT Set State** block.

Order of Network Events

Simulink Real-Time EtherCAT schedules network events according to the order of execution of the EtherCAT blocks. There are two major rate groups: one for the **EtherCAT Sync SDO Upload** and **EtherCAT Sync SDO Download** blocks, and another for the rest of the EtherCAT blocks.

- 1 **EtherCAT Init** (phase 1) — Reads data from EtherCAT variables from the last received frame into **EtherCAT PDO Receive** blocks.
- 2 Either of the following blocks, in arbitrary order:
 - **EtherCAT PDO Receive** — Processes data read from the last frame received from a slave device.
 - **EtherCAT PDO Transmit** — Buffers data to send in the next frame to a slave device.
- 3 Each of the following blocks, in arbitrary order:
 - **EtherCAT Sync SDO Upload** — Queues an SDO frame with new value, waits for response.

- EtherCAT Sync SDO Download — Queues an SDO frame with request for data, waits for response.
- EtherCAT Async SDO Upload — Queues an SDO frame with new value, checks for response, continues execution.
- EtherCAT Async SDO Download — Queues an SDO frame with request for data, checks for response, continues execution.

Upload and download take at least three ticks of the fastest PDO cycle time to complete processing.

- EtherCAT Get State — Reads current state of EtherCAT network.
 - EtherCAT Set State — Queues request to change current state of EtherCAT network.
- 4 EtherCAT Init (phase 2) — Sends the PDO frames, followed by the next available queued SDO frames.

See Also

Blocks

EtherCAT Init

Blocks

EtherCAT PDO Receive | EtherCAT PDO Transmit

Blocks

EtherCAT Async SDO Download | EtherCAT Async SDO Upload | EtherCAT Sync SDO Download | EtherCAT Sync SDO Upload

Blocks

EtherCAT Get State | EtherCAT Set State

More About

- “Fixed-Step Size Derivation” on page 12-21
- “EtherCAT Protocol Mapping” on page 12-22
- “EtherCAT Configurator Component Mapping” on page 12-23
- “Ethernet Chip Sets Compatible with EtherCAT” on page 12-24
- “EtherCAT Data Types” on page 12-27

- “EtherCAT Init Block Error Values” on page 12-28
- “EtherCAT Init Block DC Error Values” on page 12-30

Install EtherCAT Network and Configuration Software

To install the EtherCAT network and configuration software, execute the following steps. For requirements, see “EtherCAT Installation and Setup Requirements” on page 12-7.

- 1** Record the PCI bus and PCI slot for the existing Ethernet cards in the development computer. Include cards used to access your local area network and the card used to link the development and target computers.
- 2** Install a dedicated, EtherCAT compatible Ethernet card on the development computer.
- 3** Record the PCI bus and PCI slot for the new Ethernet card. Verify the PCI bus and PCI slot for the existing cards.
- 4** Download or purchase the Beckhoff ET9000 EtherCAT Configurator software (www.beckhoff.com).
- 5** Install the Beckhoff ET9000 software on your development computer.

The next task is “Configure EtherCAT Network” on page 12-8.

External Websites

- www.beckhoff.com
- www.acontis.com/eng

EtherCAT Installation and Setup Requirements

For both the development and target computers, the EtherCAT I/O module has the following requirements:

- Each Ethernet card must be compatible with EtherCAT communication. For a list of supported chip sets, see “Ethernet Chip Sets Compatible with EtherCAT” on page 12-24.
- Each Ethernet card must use a static IP address and a nonroutable subnet.

For information on setting up the dedicated Ethernet card, see your network administrator.

- On the target computer, install two Ethernet cards. Dedicate one card to linking the development and target computers. Dedicate the other to model-based EtherCAT communication.
- On the development computer, as a best practice, install two Ethernet cards in addition to your local area network card. Dedicate one card to linking the development and target computers. Dedicate the other to EtherCAT network configuration.

With only one card on the development computer, before configuring the EtherCAT network, unplug the Ethernet link cable and plug in the EtherCAT network cable. Before building and downloading the model, unplug the EtherCAT network cable, plug in the Ethernet link cable, disable the EtherCAT filter, and restart your development computer.

The Beckhoff ET9000 software runs only on a 32-bit Windows[®] compatible computer. Configure the development computer Ethernet card to enable only the Internet Protocol Version 4 (TCP/IPv4) driver. See the Beckhoff ET9000 documentation for information on manually creating an EtherCAT configuration file.

Configure EtherCAT Network

To configure the EtherCAT network using the Beckhoff ET9000 EtherCAT Configurator, execute the following steps. The model comes from example EtherCAT Communication - Analog I/O.

Before configuring the network, carry out the steps in “Install EtherCAT Network and Configuration Software” on page 12-6.

Scan EtherCAT Network

To scan an EtherCAT network using the Beckhoff ET9000 EtherCAT Configurator program:

- 1 Connect your EtherCAT network to the development computer Ethernet port dedicated to EtherCAT. Turn on the network.
- 2 Start the Beckhoff ET9000 software from Windows.
- 3 Right-click **I/O Devices** and select **Scan Devices**.

A dialog box opens stating that not all types of devices can be found automatically.

- 4 Click **OK**.

A dialog box opens listing Ethernet devices on the development computer.

- 5 Select the check box next to the Ethernet device into which you plugged your EtherCAT network. If you do not see an Ethernet device identified as an EtherCAT device, check your EtherCAT network configuration and power supply.
- 6 Click **OK**.
- 7 In the dialog box, click **Yes**.

An EtherCAT device hierarchy appears under **I/O Devices**. A dialog box opens asking if you want to activate free run mode.

- 8 Click **No**.
- 9 Expand **Term 1**, **Term 2**, and **Term 3**. then click the **EtherCAT** tab.

The Beckhoff ET9000 window looks like this figure.

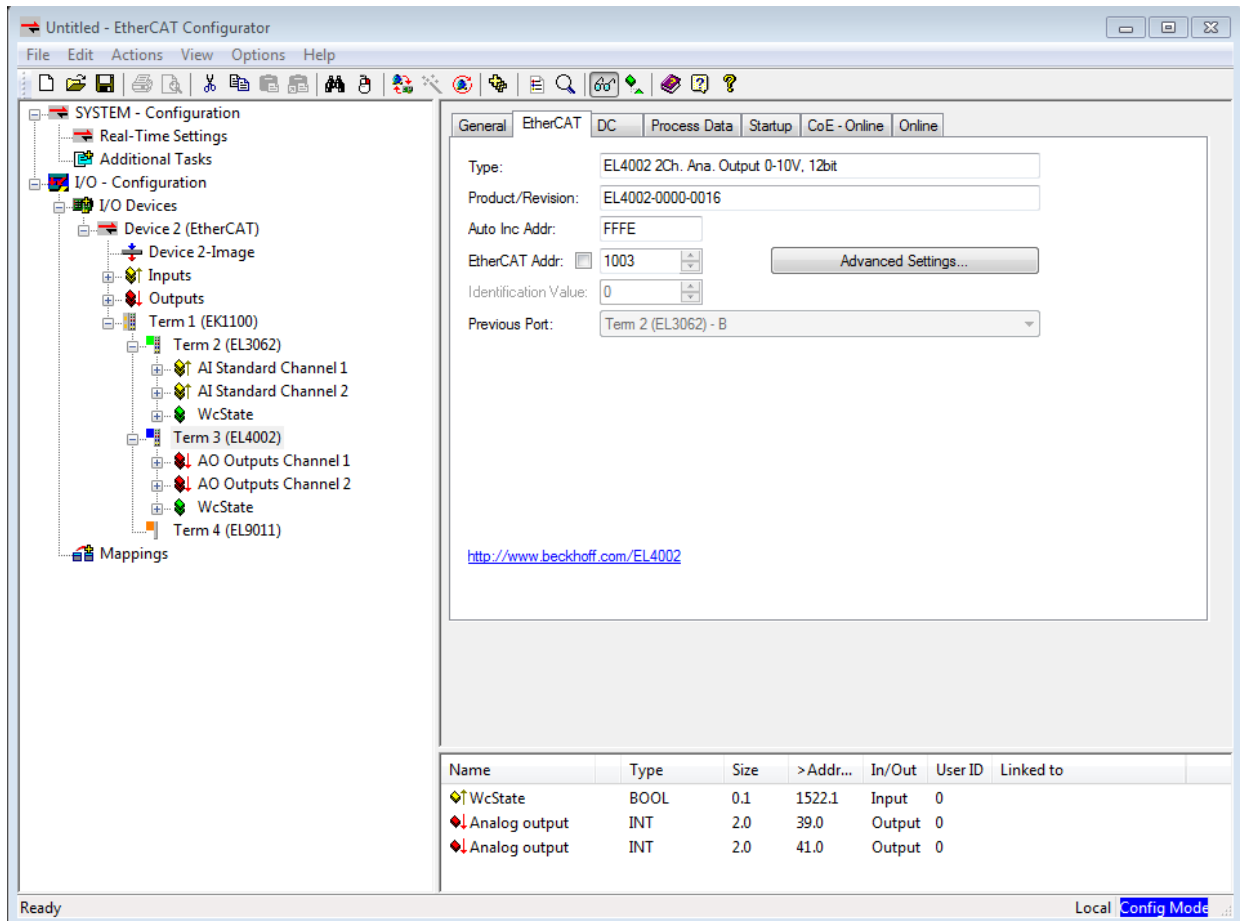

Configure EtherCAT Master Node Data

Before configuring the master node of an EtherCAT network, scan the network using the Beckhoff ET9000 EtherCAT Configurator program.

To configure the master node, execute the following steps.

Create EtherCAT Task

Before creating an EtherCAT task and configuring its time settings, scan the network using the Beckhoff ET9000 EtherCAT Configurator program.

To create and configure an EtherCAT task, execute the following steps.

- 1 Right-click **Additional Tasks** and select **Append Task**.

A dialog box opens prompting you for a name and comments.

- 2 Click **OK** to accept the default name, here **Task 1**.

An EtherCAT task hierarchy appears under **Additional Tasks**.

- 3 Click node **Task 1**, and then set the **Cycle ticks** box to **10** in the **Task** tab. This value sets the cycle time to **10** milliseconds, displayed in the box labeled **ms**.

Note the cycle time in milliseconds. In the Configuration Parameters dialog box, you use the cycle time to calculate a value for the **Fixed-step size (fundamental sample time)** box.

The Beckhoff ET9000 window looks like this figure.

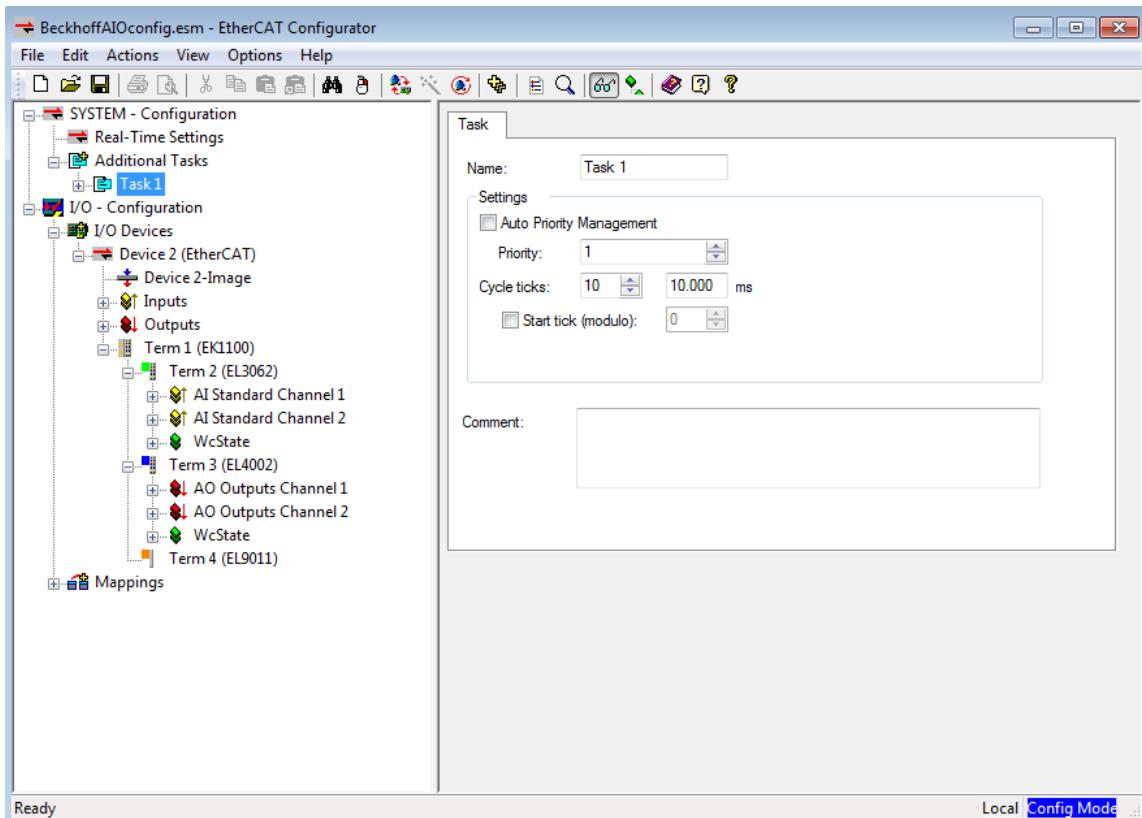

Configure EtherCAT Task Inputs

To configure the inputs of an EtherCAT task, add and configure a task using the Beckhoff ET9000 EtherCAT Configurator program.

To configure the task inputs, execute the following steps.

- 1 Expand nodes **Term 2** and **AI Standard Channel 1**.
- 2 Click and drag node **Value** under **AI Standard Channel 1** to **Inputs** under **Task 1**.
- 3 Click **Value** under **Inputs** and select the **Variable** tab.
- 4 Click the **Linked to** button.

A dialog box opens for attaching a variable to an input.

- 5 Select the first **Value** entry under **Term 2**, and then click **OK**.

The Beckhoff ET9000 window looks like this figure.

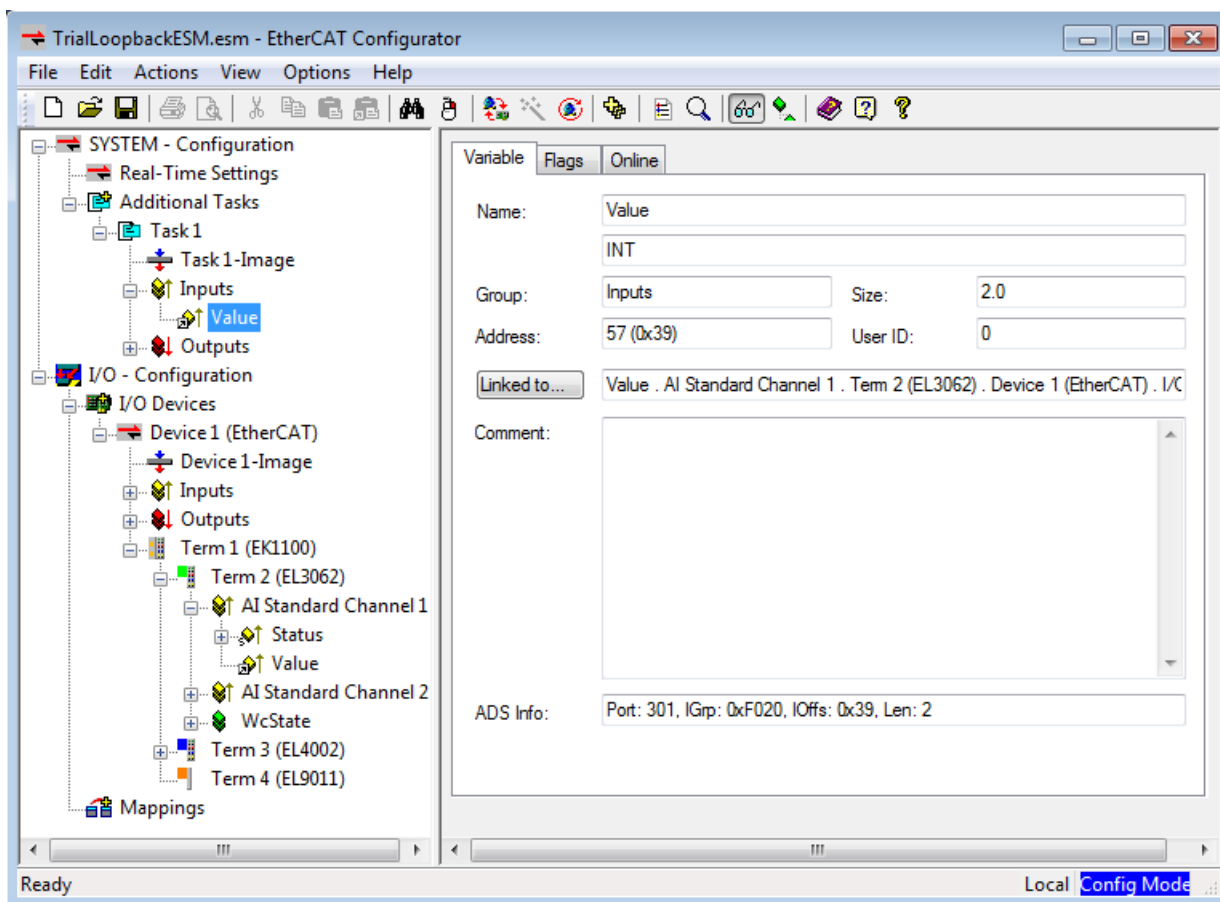

Configure EtherCAT Task Outputs

To configure the outputs of an EtherCAT task, add and configure a task using the Beckhoff ET9000 EtherCAT Configurator program.

To configure the task outputs, execute the following steps.

- 1 Expand nodes **Term 3** and **AO Outputs Channel 1**.
- 2 Click and drag node **Analog output** under **AO Outputs Channel 1** to **Outputs** under **Task 1**.
- 3 Click **Analog output** under **Outputs** and select the **Variable** tab.
- 4 Click the **Linked to** button.

A dialog box opens for attaching a variable to an output.

- 5 Select the first **Analog output** entry under **Term 3** and click **OK**.

The Beckhoff ET9000 window looks like this figure.

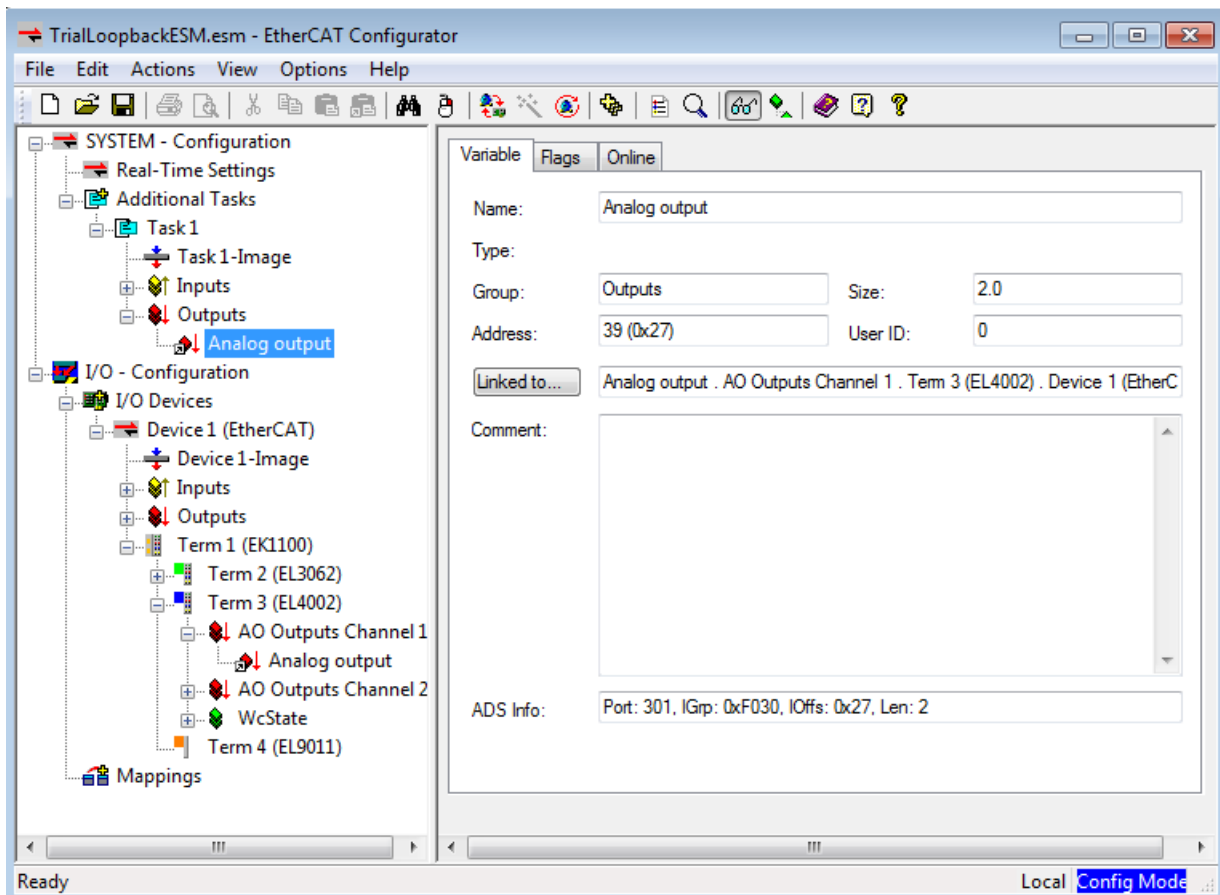

Export and Save EtherCAT Configuration

The EtherCAT Network Information (ENI) file represents the master node of an EtherCAT network. To create the ENI file, scan and configure the network using the Beckhoff ET9000 EtherCAT Configurator program. To export the ENI file, execute the following steps.

- 1 Click node **Device 1 (EtherCAT)**, and then click the **EtherCAT** tab.
- 2 Click **Export Configuration File**.
- 3 In the file save dialog box, enter an XML file name, such as **BeckhoffAI0config.xml**, and then click **Save**. Do not name the ENI file required by a Simulink Real-Time model already named `modelName` with the name `modelName.xml`.
- 4 Click **File > Save**.
- 5 In the file save dialog box, enter an ESM file name, such as **BeckhoffAI0config.esm**, and then click **Save**.

To review or modify your configuration, open the ESM file using the Beckhoff ET9000 EtherCAT Configurator program. If you modify the configuration, save both the XML and ESM files. If the ESM file is not present, the Beckhoff ET9000 program cannot open the XML file. The same is true for the Beckhoff TwinCAT program.

The next task is “Install EtherCAT Network for Execution” on page 12-15.

Install EtherCAT Network for Execution

To install the EtherCAT Network for execution using the target computer as master node, execute the following steps. For requirements, see “EtherCAT Installation and Setup Requirements” on page 12-7.

- 1** Record the PCI bus and PCI slot for the existing Ethernet cards in the target computer. For more on identifying and selecting Ethernet cards for linking the development and target computers, see “Ethernet Card Selection by Index”.
- 2** Install a dedicated, EtherCAT compatible Ethernet card on the target computer.
- 3** Record the PCI bus and PCI slot for the new Ethernet card. Verify the PCI bus and PCI slot for the existing card. Update the Simulink Real-Time environment settings to select the Ethernet card required for the Ethernet link.
- 4** Connect your EtherCAT network to the target computer Ethernet port dedicated to EtherCAT. Turn on the network.

The next task is “Configure EtherCAT Master Node Model” on page 12-16.

Configure EtherCAT Master Node Model

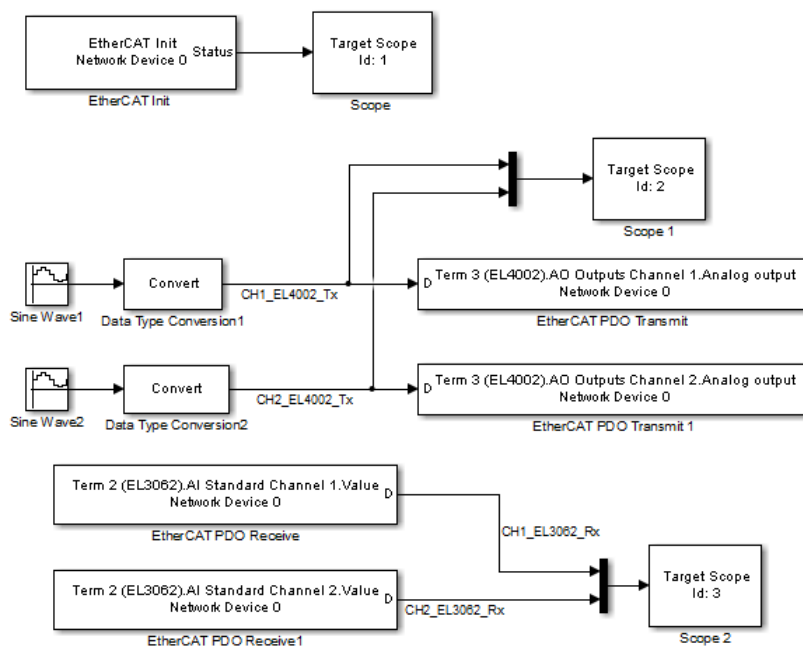

To configure model `xpcEthercatBeckhoffAI0` for execution using the target computer as master node, execute the following steps.

Before configuring the model, carry out the steps in “Configure EtherCAT Network” on page 12-8.

Configure EtherCAT Init Block

To configure the EtherCAT Init block of model `xpcEthercatBeckhoffAI0`, execute the following steps.

Before you use the EtherCAT Init block, configure the EtherCAT network using the Beckhoff ET9000 configurator. As part of this process, create and save an EtherCAT Network Information (ENI) file. See “Configure EtherCAT Network” on page 12-8.

- 1 Open model xpcEthercatBeckhoffAI0.
- 2 Double-click the EtherCAT Init block.
- 3 At the **Config file (ENI)** text box, browse to the EtherCAT Network Information (ENI) file that you created when you configured the network (here, 'BeckhoffAI0config.xml'). You can enter the file name with or without single quotes.
- 4 Take the default value 0 for parameter **Device index**.

If the model includes more than one EtherCAT network, enter a unique **Device index** for each network. Enter the same value for all blocks in each network.

- 5 Enter the **PCI bus** and **PCI slot** you recorded while configuring the EtherCAT I/O module for execution. See “Install EtherCAT Network for Execution” on page 12-15.
- 6 Take the default value Large model for parameter **DC Tuning**.

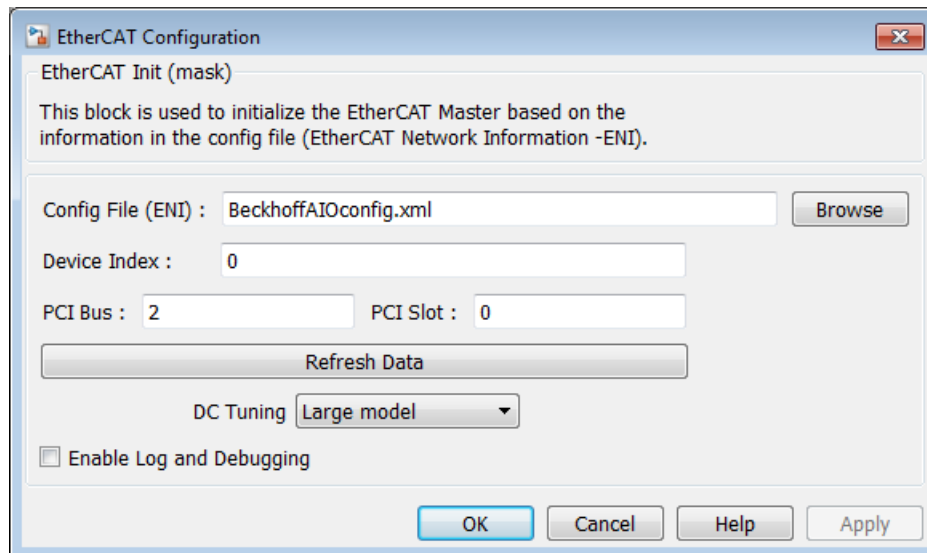

- 7 Click **Refresh Data** to read the ENI file and store the data in the EtherCAT Init block.
- 8 Click **OK**.

Configure EtherCAT PDO Receive Blocks

To configure the EtherCAT PDO Receive blocks of model `xpcEthercatBeckhoffAI0`, execute the following steps. You must have used the Beckhoff ET9000 configurator to configure the EtherCAT network.

- 1 Double-click the EtherCAT PDO Receive block labeled EtherCAT PDO Receive.
- 2 Set parameter **Device Index** to the value set in the EtherCAT Init block.
- 3 From the **Signal Name** list, select the EtherCAT network being accessed, here Term 2 (EL3062).AI Standard Channel 1.Value.
- 4 Note the value of parameter **Sample Time**, which is in seconds.

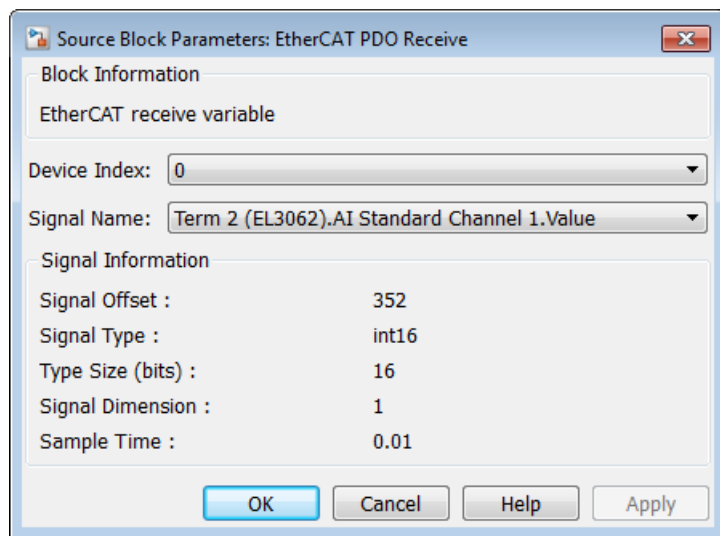

- 5 Click **OK**.

Execute steps 5–9 for the EtherCAT PDO Receive block labeled EtherCAT PDO Receive 1.

Configure EtherCAT PDO Transmit Blocks

To configure the EtherCAT PDO Transmit blocks of model `xpcEthercatBeckhoffAI0`, execute the following steps. You must have used the Beckhoff ET9000 configurator to configure the EtherCAT network.

- 1 Open model xpcEthercatBeckhoffAIO.
- 2 Double-click the EtherCAT PDO Transmit block labeled EtherCAT PDO Transmit.
- 3 Set parameter **Device Index** to the value set in the EtherCAT Init block.
- 4 Select a **Signal Name** value consistent with the EtherCAT network being accessed, here Term 3 (EL4002).AO Outputs Channel 1.Analog output.
- 5 Note the value of parameter **Sample Time**, which is in seconds.

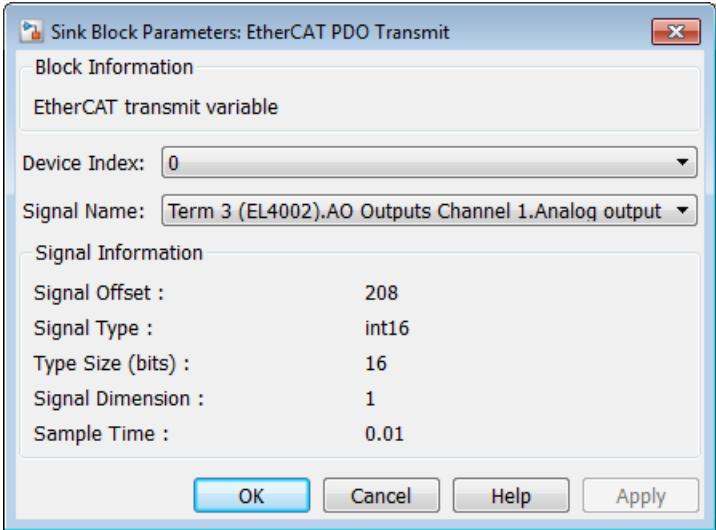

- 6 Click **OK**.

Execute steps 2–6 for the EtherCAT PDO Transmit block labeled EtherCAT PDO Transmit 1.

Configure EtherCAT Model Configuration Parameters

To configure the configuration parameters for model xpcEthercatBeckhoffAIO, execute the following steps. You must have used the Beckhoff ET9000 configurator to configure the EtherCAT network. For more information, see “Fixed-Step Size Derivation” on page 12-21.

- 1 Open model xpcEthercatBeckhoffAIO.

- 2 Calculate the greatest common divisor (GCD) of the **Sample Time** values for the EtherCAT tasks and for all source blocks in the model. In this case, the GCD is 0.010.
- 3 In the Model Editor, click **Simulation > Model Configuration Parameters** and click the **Solver** tab.
- 4 Set the **Type** parameter to **Fixed-step** and **Fixed-step size (fundamental sample time)** to one of the following:
 - An integral divisor of the GCD value, in seconds.
 - **auto**, if all other source blocks in the model have defined sample times.

In this case, set it to 0.010.

The model configuration parameters dialog box looks like this figure.

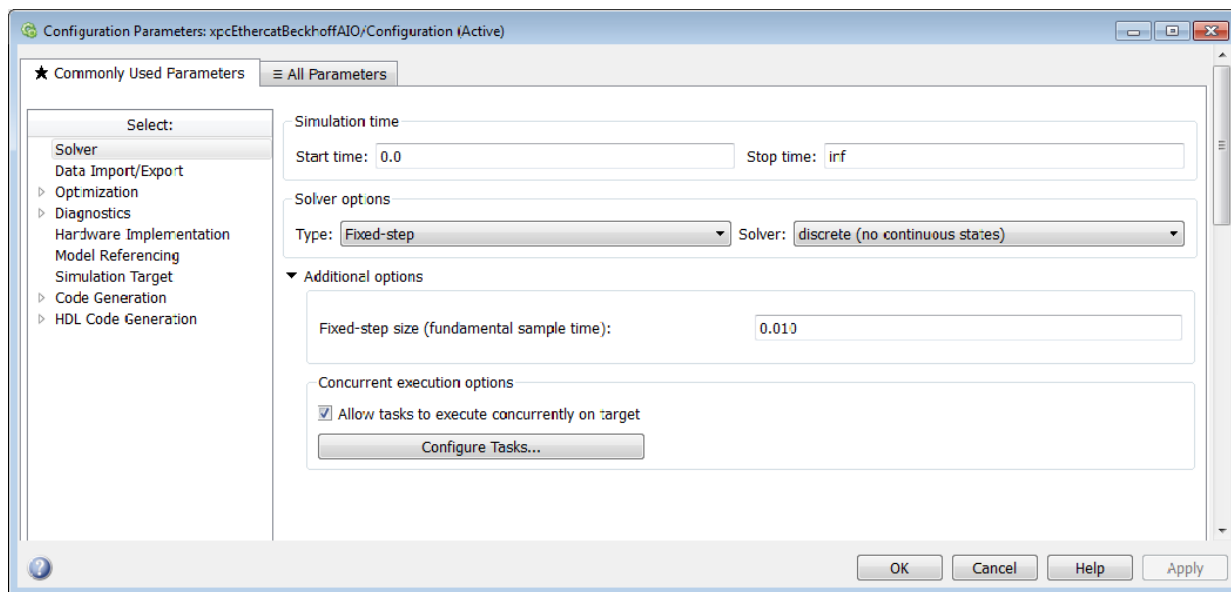

- 5 Click **OK**.

The next tasks are building, downloading, and executing the EtherCAT master node model.

Fixed-Step Size Derivation

To configure the sample rate for an EtherCAT model, set the fixed-step size for the entire model and the sample rates for key blocks.

The fixed-step size determines the task rates of the EtherCAT tasks and the sample rates of the other source blocks in the model. Subject to the fixed step size value, the block type determines the sample rate groups: a comparatively slow rate for the synchronous SDO blocks, and another, faster rate for the rest of the blocks.

Using an EtherCAT network configurator, specify the EtherCAT task rate based on the requirements of the EtherCAT network. Choose the fixed-step size so that the GCD of the task rates and the block sample rates is an integer multiple of the fixed-step size.

The software sends all PDO data updates at the fastest specified task rate, even if you created multiple EtherCAT tasks running at different rates. The PDO read and write blocks run at the rate for the tasks containing the given EtherCAT variable.

If you know that the other source blocks have defined sample times, you can set **Fixed-step size** to `auto`. If one or more block rates are incompatible with the fixed sample time, there is an error during system update. If you do not encounter an error, from the Simulink **Display** menu, set **Sample Time > Colors** to reveal the block rates.

EtherCAT Protocol Mapping

EtherCAT supports a number of overlay protocols. Simulink Real-Time supports some of the protocols directly, provides others with minimal support, and ignores some others.

Overlay Protocol	Protocol Description	Support Type	Means of Support
CANopen over EtherCAT (CoE)	Implements CAN functionality using EtherCAT	Direct	Model CoE using SDO upload and download blocks.
Ethernet over EtherCAT (EoE)	Provides EtherCAT wrapper around Ethernet packets. EtherCAT acts as network switch	Minimal	Send wrapped EoE messages between separate slave devices.
File Access over EtherCAT (FoE)	Updates the EtherCAT board ROM	Ignored	Update the EtherCAT slave ROM using Beckhoff TwinCAT.
Functional Safety over EtherCAT (FSoE)	Sends asynchronous 'safety' messages over the network.	Ignored	
Servo over EtherCAT (SoE)	Wraps vendor-specific servo commands in a common protocol.	Ignored	

EtherCAT Configurator Component Mapping

The following table summarizes the mapping between third-party EtherCAT configurator components and Simulink Real-Time blocks and block attributes. For more information, see the documentation for the Beckhoff ET9000, the Beckhoff TwinCAT, or the Acontis EC-Engineer configurator.

EtherCAT Configurator Component		Simulink Real-Time Component
Beckhoff ET9000, TwinCAT	Acontis EC-Engineer	
Cycle ticks (task rate)	Cycle time	Sample time, Task rates
Scalars and vectors	Dimension	Dimension
BitSize	Byte size of type	Type Size
Data Type, BitSize	Data type	Signal Type
EtherCAT device variable linked to a variable in a task	All PDO variables included in default task, with no linking required.	EtherCAT PDO Receive Signal Name
Device variables in Process Image entity	EtherCAT PDO Receive or EtherCAT PDO Transmit block	EtherCAT PDO Receive or EtherCAT PDO Transmit block

See Also

EtherCAT PDO Receive | EtherCAT PDO Transmit

More About

- “EtherCAT Data Types” on page 12-27

Ethernet Chip Sets Compatible with EtherCAT

The Simulink Real-Time EtherCAT communication blocks support the Intel Gigabit Ethernet and Intel Fast Ethernet (10/100) chip sets. The Intel vendor ID is 0x8086.

Intel Gigabit Ethernet Chip Sets

Device ID	Chip Number	Chip Description
0x100E	02000	Intel PRO/1000 MT Desktop Adapter
0x1010	82546EB	Intel PRO/1000 MT Dual Port Server Adapter
0x1013	82541EI	Gigabit Ethernet Controller (Copper)
0x1019	82547EI	Gigabit Ethernet Controller (LOM)
0x1026	82545EP	Gigabit Ethernet Controller
0x104A	82566DM	Intel 82566DM Gigabit Ethernet
0x104D	82566MC	Intel 82566MC Gigabit Ethernet
0x105E	82579V	Intel PRO/1000 PT Dual Port Server Adapter
0x1075	82547EI	Gigabit Ethernet Controller
0x1076	82541EI	Gigabit Ethernet Controller
0x1078	82541ER	Gigabit Ethernet Controller
0x1079	82546EB	Dual Port Gigabit Ethernet Controller
0x107C	82541PI	Gigabit Ethernet Controller (Copper) rev 5
0x107D	82572EI	Intel 82572EI Gigabit Ethernet Controller
0x108B	PC82573V	Intel network controller (PCIE Gigabit Ethernet)
0x108C	82573E	Intel 82573E Gigabit Ethernet Controller (Copper)
0x109A	82573L	Intel PRO/1000 PL Network Adaptor
0x10A4	82571GB	Intel PRO/1000 PT Quad Port Server Adapter
0x10A7	82575EB	82575EB Gigabit Network Connection
0x10B9	82572GI	Intel PRO/1000 PT Desktop
0x10BC	82571GB	Intel PRO/1000 PT Low Profile Quad Port Server Adapter
0x10BD	82566DM	Intel 82566DM Gigabit Ethernet Adapter

Device ID	Chip Number	Chip Description
0x10C9	82576	82576 Gigabit ET Dual Port Server Adapter
0x10CE	82567V-2	Intel 82567V-2 Gigabit Network Connection
0x10D3	82574L	Intel 82574L Gigabit Ethernet Controller
0x10DE	02761028	Intel Gigabit network connection
0x10EA	82577LM	Intel 82577LM Gigabit LAN Controller
0x10EB	82577LC	Intel 82577 Gigabit Ethernet
0x10EF	82578DM	Intel 82578DM Gigabit Ethernet
0x10F0	82578DC	Intel 82578DC Gigabit Ethernet
0x10F5	82567LM	Intel 82567LM-2 Gigabit Network Connection
0x1501	82567V3	Intel 82567V3 Gigabit Network Connections
0x1502	0x04931028	Intel 82579LM Gigabit Network Card
0x1503	82579V	Gigabit Network Connection
0x150C	82583V	Intel 82583V Gigabit Ethernet Controller
0x150E	82580 QUAD	82580 Gigabit Network Connection
0x1521	I350	i350 Gigabit Network Connection
0x1526	82576	Intel Gigabit ET2 Quad Port Server Adapter
0x1527	82580 QUAD FIBRE	Intel Ethernet Server Adapter I340-F4
0x1533	210_COPPER	Intel I210 Gigabit Network Connection
0x1539	211AT	Intel Ethernet Controller I211-AT
0x153A	217LM	
0x153B	217V	
0x155A	218LM	
0x157B	210_COPPER_	Intel I210 Gigabit Network Connection
0x1559	218V	
0xABB1		
0xABB2		

Intel Fast Ethernet (10/100) Chip Sets

Device ID	Chip Number	Chip Description
0x1039	10011734	LAN Controller: 82562ET, 82562EZ, 82562VE, 82562VM
0x103A	82801DB	LAN Controller with 82562ET/EZ (CNR)
0x1050	82562EZ	Pro/100 VE Network Connection
0x1059	82551QM	Fast Ethernet PCI/CardBus Controller
0x1092	27DA	PRO/100 VE Network Controller
0x1209	8255xER/IT	Fast Ethernet Controller for XP PC
0x1229	IE22	Intel PRO/100 M Desktop Adapter: 82557, 82558, 82559, 82550, 82551
0x2449	82559ER	82559ER Integrated 10Base-T/100Base-TX Ethernet Controller
0x27DC	336C1462	Intel PRO/100 VE Desktop Adapter

EtherCAT Data Types

The Simulink Real-Time EtherCAT blocks directly support the following EtherCAT data types. The software maps other EtherCAT data types to a byte array. The byte array requires explicit conversion using `Byte Pack`, `Byte Unpack`, or `S-function` blocks.

EtherCAT Data Type	Data Type Size (bits)	Converted Simulink Data Type
bit	1	uint8
bit8	8	uint8
bitarr	8 (bit array)	uint8
bitarr16	16 (bit array)	uint16
bitarr32	32 (bit array)	uint32
BOOL	1	Boolean
int8	8	int8
int16	16	int16
int32	32	int32
int64	64	int64
uint8	8	uint8
uint16	16	uint16
uint32	32	uint32
uint64	64	uint64
float	32	real32_T
double	64	real_T

EtherCAT Init Block Error Values

The Simulink Real-Time EtherCAT Init block returns the following EtherCAT error values. The value 0 indicates that no error occurred.

The block clears `ErrVal` after you read it. To hold it for later examination, send it to a `Enabled Subsystem` block. Configure the block to hold a nonzero input value and pass it through to the output.

Error Value	Description
65537 (0x10001)	Cyclic command: working counter error
65538 (0x10002)	Master initialization command: working counter error
65539 (0x10003)	Slave initialization command: working counter error
65540 (0x10004)	EOE mailbox receive: working counter error
65541 (0x10005)	COE mailbox receive: working counter error
65542 (0x10006)	FOE mailbox receive: working counter error
65543 (0x10007)	EOE mailbox send: working counter error
65544 (0x10008)	COE mailbox send: working counter error
65545 (0x10009)	FOE mailbox send: working counter error
65546 (0x1000a)	Got no response on a sent Ethernet frame
65547 (0x1000b)	Got no response on a sent EtherCAT initialization command from slave
65548 (0x1000c)	Got no response on a sent EtherCAT master initialization command
65549 (0x1000d)	Missing EtherCAT command in received Ethernet frame
65550 (0x1000e)	Timeout when waiting for mailbox initialization command response
65551 (0x1000f)	Not all slave devices are in operational state when receiving cyclic frames
65552 (0x10010)	Ethernet link (cable) not connected
65553 (0x10011)	Not in use
65554 (0x10012)	Redundancy: line break detected

Error Value	Description
65555 (0x10013)	At least one slave is in error state when receiving cyclic frames (BRD AL-STATUS)
65556 (0x10014)	Slave error status information
65557 (0x10015)	Fixed station address lost (or slave missing) - FPRD to AL_STATUS failed
65558 (0x10016)	SOE mailbox receive: working counter error
65559 (0x10017)	SOE mailbox send: working counter error
65560 (0x10018)	SOE mailbox write responded with an error
65561 (0x10019)	COE mailbox SDO abort
65562 (0x1001a)	Client registration dropped, possibly call to ecatConfigureMaster by other thread (RAS)
65563 (0x1001b)	Redundancy: line is repaired
65564 (0x1001c)	FOE mailbox abort

EtherCAT Init Block DC Error Values

The Simulink Real-Time EtherCAT Init block returns the following EtherCAT distributed clock (DC) error values. The value 0 indicates that no error occurred.

Error Value	Description
1 (0x1)	Init function not called or not successful
2 (0x2)	Controller error — synchronization out of limit
3 (0x3)	Not enough memory
4 (0x4)	Hardware layer — (BSP) invalid
5 (0x5)	Hardware layer — error modifying the timer
6 (0x6)	Hardware layer — timer is not running
7 (0x7)	Hardware layer — function is called on wrong CPU
8 (0x8)	Invalid DC sync period length
9 (0x9)	Error DCM Controller SetVal is too small
10 (0xA)	Error DCM Controller — Drift between local timer and ref clock too high

EtherCAT Blocks

EtherCAT Init
EtherCAT PDO Receive
EtherCAT PDO Transmit
EtherCAT Get State
EtherCAT Set State
EtherCAT Sync SDO Upload
EtherCAT Sync SDO Download
EtherCAT Async SDO Upload
EtherCAT Async SDO Download

EtherCAT Init

Initialize EtherCAT Master node with data in Beckhoff configuration file

Library

Simulink Real-Time Library for EtherCAT

Description

The **EtherCAT Init** block initializes the EtherCAT master stack. The block specifies the Ethernet interface cards in the network.

Before you use this block, create and save an EtherCAT Network Information (ENI) file. You export the ENI file from one of these EtherCAT configurators: the Beckhoff ET9000, the Beckhoff TwinCAT, or the Acontis EC-Engineer. See “Configure EtherCAT Network” on page 12-8.

Click **Browse** to find the ENI file. To read the ENI file and store the data in the **EtherCAT Init** block, click **Refresh Data**.

The Simulink Real-Time software supports multiple EtherCAT networks. To use multiple networks:

- Use a different Ethernet card interface for each EtherCAT network.
- In the model, use one **EtherCAT Init** block for each network.

Block Outputs

Name	Description
Status	A vector containing six values: [ErrVal MasterState DCErrVal MasterToNetworkClkDiff DCInitState NetworkToSlaveClkDiff]

- **ErrVal** — 0 if no error occurs. Otherwise, this element contains a value from “EtherCAT Init Block Error Values” on page 12-28.

After you read `ErrVal`, the block clears the status variable. To hold `ErrVal` for later examination, send it to an **Enabled Subsystem** block. Configure the block to hold a nonzero input value and pass it through to the output.

- **MasterState** — one of the following states.

State	Value	Description
INIT	1	Initialization — The system finds slave devices and initializes the communication controller.
PREOP	2	Preoperational — The system uses the communication controller to exchange system-specific initialization data. In this state, the network cannot transmit or receive signal data.
SAFEOP	4	Safe operational — The network is running and ready for full operation. The master sends input data to the slave device. The slave device output remains in a safe state.
OP	8	Operational — The network is in full operation. The master sends input data to the slave device. The slave device responds with output data.

- **DCErrVal** — 0 if the distributed clock is turned off or if no error occurs. Otherwise, this element contains a value from “EtherCAT Init Block DC Error Values” on page 12-30.
- **MasterToNetworkClkDiff** — Difference, in nanoseconds, between the master stack clock on the target computer and the clock on the first EtherCAT slave device that has enabled DC.
- **DCInitState** — 1, if the distributed clock has been started. If 0, DC has not yet been initialized or the XML configuration file did not enable DC.
- **NetworkToSlaveClkDiff** — Difference, in nanoseconds, between the clock on the first EtherCAT slave device and the least closely locked clock on the remaining slave devices. Applies only to slave devices that have enabled DC. If only one device on the network has enabled DC, this value is 0.

Block Parameters

Config file (ENI)

Specify the ENI file that you exported from the EtherCAT configurator.

You can specify the full path name or a partial path name. If you specify only the file name, the software searches for the file in the current folder and on the MATLAB path. If more than one file with that name exists on the path, MATLAB displays a message box where you select the file that you want.

Clicking **Browse** inserts a full, editable path name.

Device index

A unique integer in the range 0 to 15 that identifies the Ethernet card for an EtherCAT network.

For each EtherCAT network, the software generates a unique device index. The software inserts that device index as **Device index** into the **EtherCAT Init** block that represents the network.

PCI bus

Enter the PCI bus number for the Ethernet card.

PCI slot

Enter the PCI slot number for the Ethernet card.

DC Tuning

Enter the distributed clock initialization parameter, one of these values:

- **Large model** (default) — Sends 16,000 timing initialization packets and allows 1 second of settling time. Provides best initial synchronization between multiple slaves that have DC enabled.
- **Medium model** — Sends 8,000 timing initialization packets and allows 0.3 seconds of settling time. The model reaches operational state about a second earlier than it does with the **Large model** setting.
- **Small model** — Sends 2,000 timing initialization packets and allows 0.2 seconds of settling time. The model reaches operational state earlier than it does with the other settings.

Monitor device synchronization at the moment that the model enters the operational state. Verify that the devices are synchronized closely enough for your application.

Enable Log and Debugging

Select this check box to enable access to debugging and logging block parameters.

When you select **Enable Log and Debugging**, the following block parameters are visible.

Enable DC

Selected by default. Clear it only for driver and network debugging.

To disable distributed clocks for a reason other than debugging, modify the configuration file to disable the clocks. Do not clear the **Enable DC** check box unless MathWorks® technical support suggests that you do so.

Log link layer error messages**Log master state changes****Log all state changes****Log base clock changes****Log master config changes**

Select these check boxes to generate driver-level messages for driver and network debugging.

For a high-speed model, turning these options on can cause CPU overloads.

Target log filename

Enter the name of the log file on the target computer, in single quotes. The default value is 'c:\dbglog.txt'.

If the target computer does not have a usable disk partition, the software does not create the log file.

See Also

“EtherCAT Init Block Error Values” on page 12-28 | “EtherCAT Init Block DC Error Values” on page 12-30 | **Enabled Subsystem**

External Websites

- www.ethercat.org
- www.beckhoff.com
- www.acontis.com/eng

EtherCAT PDO Receive

Receive data from slave device represented by process data object

Library

Simulink Real-Time Library for EtherCAT

Description

The EtherCAT PDO Receive block receives data from the EtherCAT slave device.

The block parameter dialog box has two sections, parameters and signal information. When you specify an EtherCAT network and device variable name:

- The EtherCAT PDO Receive block mask is updated with the selected signal name.
- The signal information in the block parameter dialog box is updated to reflect the device variable.

Note: If an error occurs while the software parses the configuration file specified in the EtherCAT Init block, this block shows an error message.

Block Outputs

Name	Description
D	Data received from the EtherCAT slave device.

Block Parameters

Device index

A unique integer in the range 0 to 15 that identifies the Ethernet card for an EtherCAT network.

To associate a block with an EtherCAT network, copy the **Device index** value from the EtherCAT Init block representing that network into the **Device index** for the block.

The default value of **Device index** is 0.

Signal name

From the list, select the EtherCAT device variable name.

The block parameter dialog box updates the signal information to reflect the device variable that you selected.

Signal Information	Description
Signal Offset	Location in the process image from which the data is available after the execution of the EtherCAT Init block. This value is the EtherCAT configurator BitOffs – 80.
Signal Type	The Simulink data type for the EtherCAT data. For a mapping of Simulink data types to EtherCAT data types, see “EtherCAT Data Types” on page 12-27
Type Size (bits)	Size of the EtherCAT data type. See “EtherCAT Data Types” on page 12-27 for a mapping of Simulink data types to the EtherCAT data types and data type sizes.
Signal Dimension	Dimension of the signal. The EtherCAT blocks support scalars and vectors (dimension of 1).
Sample Time	Rate at which this block is executed. This rate is the execution rate of the EtherCAT task, as specified in the Beckhoff ET9000 EtherCAT configurator.

External Websites

- www.ethercat.org
- www.beckhoff.com
- www.acontis.com/eng

EtherCAT PDO Transmit

Send data to slave device represented by process data object

Library

Simulink Real-Time Library for EtherCAT

Description

The EtherCAT PDO Transmit block transmits computed data to a particular variable in the EtherCAT slave device.

The block parameter dialog box has two sections, parameters and signal information. When you specify an EtherCAT network and device variable name:

- The EtherCAT PDO Receive block mask is updated with the selected signal name.
- The signal information in the block parameter dialog box is updated to reflect the device variable.

Note: If an error occurs while the software parses the configuration file specified in the EtherCAT Init block, this block shows an error message.

Block Inputs

Name	Description
D	Data to transmit to the EtherCAT slave device.

Block Parameters

Device index

A unique integer in the range 0 to 15 that identifies the Ethernet card for an EtherCAT network.

To associate a block with an EtherCAT network, copy the **Device index** value from the EtherCAT Init block representing that network into the **Device index** for the block.

The default value of **Device index** is 0.

Signal name

From the list, select the EtherCAT device variable name.

The block parameter dialog box updates the signal information to reflect the device variable that you selected.

Signal Information	Description
Signal Offset	Location in the process image from which the data is available after the execution of the EtherCAT Init block. This value is the EtherCAT configurator BitOffs – 80.
Signal Type	The Simulink data type for the EtherCAT data. For a mapping of Simulink data types to EtherCAT data types, see “EtherCAT Data Types” on page 12-27
Type Size (bits)	Size of the EtherCAT data type. See “EtherCAT Data Types” on page 12-27 for a mapping of Simulink data types to the EtherCAT data types and data type sizes.
Signal Dimension	Dimension of the signal. The EtherCAT blocks support scalars and vectors (dimension of 1).
Sample Time	Rate at which this block is executed. This rate is the execution rate of the EtherCAT task, as specified in the Beckhoff ET9000 EtherCAT configurator.

External Websites

- www.ethercat.org
- www.beckhoff.com
- www.acontis.com/eng

EtherCAT Get State

Get state of EtherCAT network

Library

Simulink Real-Time Library for EtherCAT

Description

The EtherCAT Get State block returns the state of the EtherCAT network.

State	Value	Description
INIT	1	Initialization – The system finds slave devices and initializes the communication controller.
PREOP	2	Preoperational — The system uses the communication controller to exchange system-specific initialization data. In this state, the network cannot transmit or receive signal data.
SAFEOP	4	Safe operational — The network is running and ready for full operation. The master sends input data to the slave device. The slave device output remains in a safe state.
OP	8	Operational — The network is in full operation. The master sends input data to the slave device. The slave device responds with output data.

Block Outputs

Name	Description
State	Reception from the EtherCAT network.

Block Parameters

Device index

A unique integer in the range 0 to 15 that identifies the Ethernet card for an EtherCAT network.

To associate a block with an EtherCAT network, copy the **Device index** value from the EtherCAT Init block representing that network into the **Device index** for the block.

The default value of **Device index** is 0.

Sample time

Enter the base sample time or a multiple of the base sample time (- 1 means sample time is inherited).

External Websites

- www.ethercat.org
- www.beckhoff.com
- www.acontis.com/eng

EtherCAT Set State

Set state of EtherCAT network

Library

Simulink Real-Time Library for EtherCAT

Description

The EtherCAT Set State block sets the state of the EtherCAT network. Each state has the corresponding integer:

State	Value	Description
INIT	1	Initialization – The system finds slave devices and initializes the communication controller.
PREOP	2	Preoperational — The system uses the communication controller to exchange system-specific initialization data. In this state, the network cannot transmit or receive signal data.
SAFEOP	4	Safe operational — The network is running and ready for full operation. The master sends input data to the slave device. The slave device output remains in a safe state.
OP	8	Operational — The network is in full operation. The master sends input data to the slave device. The slave device responds with output data.

Block Inputs and Outputs

Inputs

Name	Description
New State	Transmission to the EtherCAT network.

Outputs

Name	Description
Prev State	Previous state of the network.
Error	0 if no error occurs. Otherwise, a nonzero value.

Block Parameters

Device index

A unique integer in the range 0 to 15 that identifies the Ethernet card for an EtherCAT network.

To associate a block with an EtherCAT network, copy the **Device index** value from the EtherCAT Init block representing that network into the **Device index** for the block.

The default value of **Device index** is 0.

Timeout

Enter the number of seconds to wait for the EtherCAT network state to transition.

Set the timeout to 0 to return immediately.

Sample time

Enter the base sample time or a multiple of the base sample time (-1 means sample time is inherited).

External Websites

- www.ethercat.org
- www.beckhoff.com
- www.acontis.com/eng

EtherCAT Sync SDO Upload

Read data synchronously from slave device represented by service data object

Library

Simulink Real-Time Library for EtherCAT

Description

The EtherCAT Sync SDO Upload block reads a CANopen dictionary entry in the specified EtherCAT slave. The block then waits until it receives a response or until the timeout period is over.

The response to an operation can take several ticks of the main task sample time. Assign the synchronous blocks a sample time slower than the main task sample time.

Block Outputs

Name	Description
Data	Data received from the EtherCAT slave device.
Error	0 if no error occurs. Otherwise, a nonzero value.

Block Parameters

Index

Specify the decimal index of the CANopen dictionary entry.

If you specify an invalid index, the block does not return an error or a time out. The results are undefined.

Subindex

Specify the decimal subindex of the CANopen dictionary entry.

If you specify an invalid subindex, the block does not return an error or a time out. The results are undefined.

Data Type

From the list, select the data type of the CANopen dictionary entry.

If you select a data type that does not match the type of the entry, the block returns an error.

Dimension

Specify the row and column dimension of the CANopen dictionary entry.

Enter a value of 1. EtherCAT blocks support only scalars and vectors.

Device index

A unique integer in the range 0 to 15 that identifies the Ethernet card for an EtherCAT network.

To associate a block with an EtherCAT network, copy the **Device index** value from the EtherCAT Init block representing that network into the **Device index** for the block.

The default value of **Device index** is 0.

Slave Name

From the list, select the name of the slave that contains the CANopen data dictionary variable.

The block populates this drop-down list with the contents of the configuration file.

Sample time

Enter the base sample time or a multiple of the base sample time (- 1 means sample time is inherited).

Timeout

Enter the number of milliseconds to wait for a response from the EtherCAT slave.

External Websites

- www.ethercat.org
- www.beckhoff.com
- www.acontis.com/eng

EtherCAT Sync SDO Download

Transmit data synchronously to slave device represented by service data object

Library

Simulink Real-Time Library for EtherCAT

Description

The EtherCAT Sync SDO Download block writes to a CANopen dictionary entry in the specified EtherCAT slave. The block then waits until it receives a response or until the timeout period is over.

The response to an operation can take several ticks of the main task sample time. Assign the synchronous blocks a sample time slower than the main task sample time.

Block Inputs and Outputs

Inputs

Name	Description
Data	Input data for writing to the EtherCAT slave device.

Outputs

Name	Description
Error	0 if no error occurs. Otherwise, a nonzero value.

Block Parameters

Index

Specify the decimal index of the CANopen dictionary entry.

If you specify an invalid index, the block does not return an error or a time out. The results are undefined.

Subindex

Specify the decimal subindex of the CANopen dictionary entry.

If you specify an invalid subindex, the block does not return an error or a time out. The results are undefined.

Data Type

From the list, select the data type of the CANopen dictionary entry.

If you select a data type that does not match the type of the entry, the block returns an error.

Dimension

Specify the row and column dimension of the CANopen dictionary entry.

Enter a value of 1. EtherCAT blocks support only scalars and vectors.

Device index

A unique integer in the range 0 to 15 that identifies the Ethernet card for an EtherCAT network.

To associate a block with an EtherCAT network, copy the **Device index** value from the EtherCAT `Init` block representing that network into the **Device index** for the block.

The default value of **Device index** is 0.

Slave Name

From the list, select the name of the slave that contains the CANopen data dictionary variable.

The block populates this drop-down list with the contents of the configuration file.

Sample time

Enter the base sample time or a multiple of the base sample time (- 1 means sample time is inherited).

Timeout

Enter the number of milliseconds to wait for a response from the EtherCAT slave.

External Websites

- www.ethercat.org
- www.beckhoff.com
- www.acontis.com/eng

EtherCAT Async SDO Upload

Read data asynchronously from slave device represented by service data object

Library

Simulink Real-Time Library for EtherCAT

Description

The EtherCAT Async SDO Upload block requests a CANopen dictionary entry from the specified EtherCAT slave. It then immediately returns whatever value was returned from the device on an earlier call to the block.

Block Inputs and Outputs

Inputs

Name	Description
Enable	When true, the block uploads data.

Outputs

Name	Description
Data	Data received from the EtherCAT slave device.
Status	One of the following values: <ul style="list-style-type: none"> • 0 — Mailbox transfer object idle, transfer not running • 1 — Mailbox transfer object running, transfer not complete • 2 — Transfer successfully executed • 3 — Error occurred during transfer request

Block Parameters

Index

Specify the decimal index of the CANopen dictionary entry.

If you specify an invalid index, the block does not return an error or a time out. The results are undefined.

Subindex

Specify the decimal subindex of the CANopen dictionary entry.

If you specify an invalid subindex, the block does not return an error or a time out. The results are undefined.

Data Type

From the list, select the data type of the CANopen dictionary entry.

If you select a data type that does not match the type of the entry, the block returns an error.

Dimension

Specify the row and column dimension of the CANopen dictionary entry.

Enter a value of 1. EtherCAT blocks support only scalars and vectors.

Device index

A unique integer in the range 0 to 15 that identifies the Ethernet card for an EtherCAT network.

To associate a block with an EtherCAT network, copy the **Device index** value from the EtherCAT `Init` block representing that network into the **Device index** for the block.

The default value of **Device index** is 0.

Slave Name

From the list, select the name of the slave that contains the CANopen data dictionary variable.

The block populates this drop-down list with the contents of the configuration file.

Sample time

Enter the base sample time or a multiple of the base sample time (- 1 means sample time is inherited).

External Websites

- www.ethercat.org
- www.beckhoff.com
- www.acontis.com/eng

EtherCAT Async SDO Download

Transmit data asynchronously to slave device represented by service data object

Library

Simulink Real-Time Library for EtherCAT

Description

The EtherCAT Async SDO Download block writes a CANopen dictionary entry in the specified EtherCAT slave. The block then immediately continues processing its input data.

Block Inputs and Outputs

Inputs

Name	Description
Data	Input data for writing to the EtherCAT slave device.
Enable	When true, the block downloads data.

Outputs

Name	Description
Status	One of the following values: <ul style="list-style-type: none">• 0 — Mailbox transfer object idle, transfer not running• 1 — Mailbox transfer object running, transfer not complete• 2 — Transfer successfully executed• 3 — Error occurred during transfer request

Block Parameters

Index

Specify the decimal index of the CANopen dictionary entry.

If you specify an invalid index, the block does not return an error or a time out. The results are undefined.

Subindex

Specify the decimal subindex of the CANopen dictionary entry.

If you specify an invalid subindex, the block does not return an error or a time out. The results are undefined.

Data Type

From the list, select the data type of the CANopen dictionary entry.

If you select a data type that does not match the type of the entry, the block returns an error.

Dimension

Specify the row and column dimension of the CANopen dictionary entry.

Enter a value of 1. EtherCAT blocks support only scalars and vectors.

Device index

A unique integer in the range 0 to 15 that identifies the Ethernet card for an EtherCAT network.

To associate a block with an EtherCAT network, copy the **Device index** value from the EtherCAT `Init` block representing that network into the **Device index** for the block.

The default value of **Device index** is 0.

Slave Name

From the list, select the name of the slave that contains the CANopen data dictionary variable.

The block populates this drop-down list with the contents of the configuration file.

Sample time

Enter the base sample time or a multiple of the base sample time (- 1 means sample time is inherited).

External Websites

- www.ethercat.org
- www.beckhoff.com
- www.acontis.com/eng

UDP

Real-Time UDP Communication Support

- “Using Real-Time UDP Communications” on page 14-2
- “Low-Level Internet Protocol Library” on page 14-3

Using Real-Time UDP Communications

Consider using the real-time UDP communication blocks for the following:

- Enhanced performance over standard UDP communications — Real-time UDP communication support requires a dedicated Ethernet card. Real-time applications use real-time UDP blocks to send and receive UDP packets through the dedicated Ethernet card. Standard UDP communication shares bandwidth with the link between the development and target computers.
- Flexible configuration — Real-time UDP communication supports variable lengths and variable numbers of packets. Standard UDP communication also supports variable lengths, but only one packet at a time.

IP fragmentation is not supported in Simulink Real-Time UDP blocks. The packet payload is limited to 1472 bytes (1500 bytes UDP packet size – 28 bytes combined packet header size).

Before you start, verify that you have a dedicated Ethernet card on your target computer. A dedicated Ethernet card is to be used only for real-time UDP communications, and not for a link between the development and target computers. This requirement means that your target computer must have at least two Ethernet cards, one for the link between the development and target computers, and one for real-time UDP communications. For a list of supported Ethernet chip families, see “What Is Model-Based Ethernet Communications?” on page 8-2.

Low-Level Internet Protocol Library

The Internet Protocol (IP) library contains blocks specific to the low-level management of the UDP network. The blocks in this sublibrary are core blocks that you might want to use to create other subsystems. However, the top-level real-time UDP blocks provide enough functionality for real-time UDP communications. To access the low-level blocks, type `xpciplib` in the MATLAB Command Window.

Real-Time UDP Blocks

Real-Time UDP Configuration
Receive
Send
UDP Consume
UDP Produce
UDP Rx
UDP Tx

Real-Time UDP Configuration

Configure network interface for real-time UDP communication

Library

Simulink Real-Time for Real-Time UDP

Description

The **Real-Time UDP Configuration** block configures the network for real-time UDP operation.

IP fragmentation is not supported in Simulink Real-Time UDP blocks. The packet payload is limited to 1472 bytes (1500 bytes UDP packet size – 28 bytes combined packet header size).

Block Parameters

Device ID

From the list, select a unique integer to identify the Ethernet board. Use this ID to associate the other UDP blocks with this board.

IP Address

Enter the IP address for the interface.

Subnet mask

Enter the subnet mask for the interface.

Gateway

Enter the gateway address for the interface.

Ethernet Driver

Identifies the driver for each chip family supported. Possible values are `Intel 8255X` and `Intel Gigabit`.

PCI bus

Enter the PCI bus number for the Ethernet card.

PCI slot

Enter the PCI slot number for the Ethernet card.

See Also

Real-Time UDP Configuration | Receive | Send

External Websites

- www.iso.org

Receive

Receive data over UDP network on a dedicated network interface

Library

Simulink Real-Time for Real-Time UDP

Description

The Receive block receives UDP data on the specified local (destination) port. To receive all data sent to this port, set **Source IP address** to 0.0.0.0, otherwise set **Source IP address** to a valid IP address.

IP fragmentation is not supported in Simulink Real-Time UDP blocks. The packet payload is limited to 1472 bytes (1500 bytes UDP packet size – 28 bytes combined packet header size).

Block Outputs

Name	Description
Data	Vector of <code>uint8</code> containing data received
N	Number of new bytes received, and otherwise 0

The default block behavior is to keep the previous output when there is no new data.

Block Parameters

Device ID

From the list, select a unique number to identify the Ethernet board. Select the same **Device ID** as the one you selected for the **Real-Time UDP Configuration** block.

Source IP address

Enter a valid IP address as a dotted decimal string, for example, `10.10.10.3`. You can also use a MATLAB expression that returns a valid IP address as a string. With **Local (destination) port**, this parameter defines the source address.

The default address, `0.0.0.0`, causes the block to accept UDP packets from any accessible computer. If set to a specific IP address, packets arriving from only that IP address are received.

Local (destination) port

Specify the port of the target computer or device from which to receive the UDP packets. With **Source IP address**, this parameter defines the source address.

Output port width

Enter the output port width.

Sample time

Enter the base sample time or a multiple of the base sample time (- 1 means sample time is inherited).

See Also

Real-Time UDP Configuration | Receive

External Websites

- www.iso.org

Send

Send data over UDP network on a dedicated network interface

Library

Simulink Real-Time for Real-Time UDP

Description

The Send block sends UDP packets from **Local (source) port** to **Destination port**. To broadcast to all devices, set **Destination IP address** to `255.255.255.255`, otherwise set **Destination IP address** to a valid IP address.

IP fragmentation is not supported in Simulink Real-Time UDP blocks. The packet payload is limited to 1472 bytes (1500 bytes UDP packet size – 28 bytes combined packet header size).

Block Inputs

Name	Description
Data	Vector of <code>uint8</code> containing data to send
N	Number of bytes to send

Block Parameters

Device ID

From the list, select a unique number to identify the Ethernet board. Select the same **Device ID** as the one you selected for the Real-Time UDP Configuration block.

Destination IP address

Specify the IP address of the target computer or other device to which you want to send the UDP packets. To broadcast the packets to all listening computers or

devices, enter 255.255.255.255. With **Destination port**, this parameter defines the destination address.

Destination port

Specify the target computer port to which you want to send the UDP packets. With **Destination IP address**, this parameter defines the destination address.

Local (source) port

Specify the target computer port from which you want to send the UDP packets.

Enter -1 to automatically assign a port for the target computer.

Sample time

Enter the base sample time or a multiple of the base sample time (-1 means sample time is inherited).

See Also

Real-Time UDP Configuration | Receive

External Websites

- www.iso.org

UDP Consume

Consume a UDP packet

Library

Simulink Real-Time Library for IP

Description

The UDP Consume block outputs a network buffer with raw data that you can output to a Network Buffer library block. To create this output, the block:

- 1 Receives as input a network buffer that contains a UDP header.
- 2 Removes the UDP header.
- 3 Outputs the updated network buffer.

The block has two output ports:

- Buffers
Chain of network buffers.
- Chain size
Number of buffers on the chain.

Block Parameters

IP Group

Enter a number in the range 0 to 7. This value identifies the IP `Init` block inside the Real-Time UDP Configuration subsystem that is associated with this block.

Output port width

Enter the width of the port. A value other than 0 creates the following output ports:

- Source IP Address

- Destination IP Address
- Local UDP Port
- Remote UDP Port

Sample time

Enter the base sample time or a multiple of the base sample time (- 1 means sample time is inherited).

External Websites

- www.iso.org

UDP Produce

Produce UDP packet by adding a UDP header to the input data

Library

Simulink Real-Time Library for IP

Description

The UDP Produce block receives a network buffer and adds a header to that buffer. It then outputs that updated buffer.

Block Parameters

IP Group

Enter a number in the range 0 to 7. This value identifies the IP `Init` block inside the Real-Time UDP Configuration subsystem that is associated with this block.

IP address to send to (255.255.255.255 for broadcast)

Specify IP address of the target computer to which to send the UDP packets. To broadcast the packets to all listening computers or devices, enter `255.255.255.255`. With **Remote IP port to send to**, this parameter defines the destination address.

Remote IP port to send to

Specify the target computer port to which to send the UDP packets. With **IP address to send to (255.255.255.255 for broadcast)**, this parameter defines the destination address.

Use the following local IP port (-1 for automatic assignment)

Specify the target computer port from which to send the UDP packets.

Enter -1 to automatically assign a port for the target computer.

Sample time

Enter the base sample time or a multiple of the base sample time (-1 means sample time is inherited).

External Websites

- www.iso.org

UDP Rx

Receive UDP packet

Library

Simulink Real-Time Library for IP

Description

The UDP Rx block outputs a network buffer with a UDP header.

Block Parameters

IP Group

Enter a number in the range 0 to 7. This value identifies the IP `Init` block inside the `Real-Time UDP Configuration` subsystem that is associated with this block.

IP address to receive from (0.0.0.0 for accepting all)

Enter a valid IP address as a dotted decimal string. For example, `10.10.10.3`. You can also use a MATLAB expression that returns a valid IP address as a string. With **IP port to receive from**, this parameter defines the source address.

The default address, `0.0.0.0`, enables the acceptance of all UDP packets from any accessible computer. If set to a specific IP address, only packets arriving from that IP address are received.

IP port to receive from

Specify the port of the target computer or device from which to receive the video frames. With **IP address to receive from (0.0.0.0 for accepting all)**, this parameter defines the source address.

Sample time

Enter the base sample time or a multiple of the base sample time (-1 means sample time is inherited).

External Websites

- www.iso.org

UDP Tx

Transmit UDP packet

Library

Simulink Real-Time Library for IP

Description

The UDP Tx block receives a network buffer with a UDP header and sends it.

Block Parameters

IP Group

Enter a number in the range 0 to 7. This value identifies the IP `Init` block inside the Real-Time UDP Configuration subsystem that is associated with this block.

Sample time

Enter the base sample time or a multiple of the base sample time (-1 means sample time is inherited).

External Websites

- www.iso.org

UDP I/O Support

- “UDP Transport Protocol” on page 16-2
- “Two-Way Data Exchange Using UDP” on page 16-5
- “UDP Communication Setup” on page 16-10
- “UDP and Variable-Size Signals” on page 16-11

UDP Transport Protocol

The Simulink Real-Time software supports communication from the target computer to other systems or devices using User Datagram Protocol (UDP) packets. UDP is a transport protocol similar to TCP. However, unlike TCP, UDP provides a direct method to send and receive packets over an IP network. UDP uses this direct method at the expense of reliability by limiting error checking and recovery.

Like TCP, UDP is a transport protocol layered on top of the Internet Protocol (IP). It is commonly known as UDP/IP, by analogy to TCP/IP. A convenient way to describe UDP/IP is by comparing it to TCP/IP:

- **Connectionless Versus Connection** — UDP is a *connectionless* protocol, whereas TCP is a *connection-based* protocol.
 - In UDP, a system prepares a packet and sends it to the receiver without checking to see if the receiver is ready to receive a packet. If the receiver is not ready, the packet is lost
 - In TCP, the two ends of the communication link must be connected throughout the communication.
- **Packet Versus Stream** — UDP is a *packet-oriented* protocol, whereas TCP is a *stream-oriented* protocol.
 - UDP is a packet-oriented protocol where the system itself divides the data into packets and sends them to the other end. The other end does not have to reassemble the data into a stream. Note, some systems can present the data as a stream when the underlying protocol is UDP. However, this behavior is the layering of an additional protocol on top of UDP, and it is not something inherent in the UDP protocol itself.
 - TCP is a long stream of data that flows from one end of the network to the other. Another long stream of data flows in the other direction. The TCP/IP stack at the transmitting end is responsible for breaking the stream of data into packets and sending those packets. The stack at the receiving end is responsible for reassembling the packets into a data stream using information in the packet headers.
- **No Error Detection Versus Error Detection** — UDP does not support error detection, whereas TCP does.

- UDP sends the packets and does not track them. Thus, if packets arrive out of sequence, or are lost in transmission, the receiving end (or the sending end) cannot know.
- TCP packets contain a unique sequence number. The starting sequence number is communicated to the other side at the beginning of communication. The receiver acknowledges each packet, and the acknowledgment contains the sequence number so that the sender knows which packet was acknowledged. Therefore, packets lost on the way can be retransmitted. The sender knows that they did not reach their destination because the sender did not receive an acknowledgment. The receiver can reassemble in order packets that arrive out of sequence. Timeouts can be established, because the sender knows from the first few packets how long it takes to transmit a packet and receive its acknowledgment.

In summary, UDP is like sending letters by mail, without a return address. If the other party is not found, or the letter is lost in transit, it is discarded. TCP communication is like a telephone conversation. A continuous connection is required, and two-way streaming data (the words spoken by each party) are exchanged. The analogy fails, however, when considering the speed of communication. Both TCP and UDP communication roughly happen at the same speed, because both use the underlying Internet Protocol (IP) layer.

Note: *Reliable* means “not guaranteed to succeed” instead of “succeeds all of the time”.

Unreliable means “packets can fail to arrive without the system detecting that the packets did not arrive” instead of “fails most of the time.”

In practice, UDP continues to receive packets as long as the receiving socket is active and processes data as quickly as it arrives.

UDP was chosen as the Simulink Real-Time transport layer because of its lightweight nature. Since the primary reason for using the Simulink Real-Time framework is real-time execution, UDP gives the real-time application a good chance of succeeding in real-time execution. Also, the datagram nature of UDP is good for sending samples of data from the real-time application generated by the Simulink Coder software. Because TCP is stream oriented, separators between sets of data must be used for the data to be processed in samples. It is easier to build an application to deal with unreliable data than it is to decode data in real time. If the real-time application cannot process the data as

quickly as it arrives, only the most recent packet is used and the following packets are ignored.

Communication can involve a packet made up of Simulink data types such as **double**, **int8**, **int32**, **uint8**, or a combination of these data types. The Simulink Real-Time block library provides blocks for combining various signals into one packet (packing), and then transmitting it. It also provides blocks for splitting a packet (unpacking) into its component signals that can then be used in a Simulink model. The maximum size of a packet is limited to about 1450 bytes.

The UDP blocks work in the background when the real-time application is not running. UDP communication is configured to support at most two UDP packets waiting to be read at one UDP port, corresponding to one UDP Receive block. Subsequent packets are rejected. This configuration prevents excessive memory usage and minimizes the load on the UDP/IP stack. Therefore, when a large background task is performed, such as uploading a screen shot or communicating large pages through the WWW interface, packet loss can occur. Design models so that the receipt of further packets after the ones that were lost bridges gaps.

Note also that because UDP block transfers operate as background tasks, the Simulink Real-Time software disables them in polling mode. See “Polling Mode”.

Two-Way Data Exchange Using UDP

This section provides an example of how to set up two-way data exchange between two Simulink Real-Time systems, between the Simulink Real-Time and Simulink products, or between two Simulink models. When one or both of the systems is running as a non-real-time Simulink model, be sure to set the sample time.

Note: To use UDP for your Simulink Real-Time system, be sure to create a TCP/IP boot disk and boot the target computer with that boot disk.

The hypothetical models are called `udpsendreceiveA` and `udpsendreceiveB`. Two different sets of data are transferred between these two models, one set from `udpsendreceiveA` to `udpsendreceiveB` and another set in the opposite direction.

The data to transfer is in the following order:

`udpsendreceiveA` to `udpsendreceiveB`

- `uint8` (3x3)
- `uint16` (1x1)
- `double` (2x4)

`udpsendreceiveB` to `udpsendreceiveA`

- `single` (4x1)
- `double` (2x2)
- `uint32` (2x2)
- `int8` (5x3)

For the purposes of this example, the inputs are generated using Simulink Constant blocks that use the MATLAB random number function (`rand`). The Simulink Coder software uses this function at the time of code generation to generate random numbers. To generate the vector of `uint8` (3x3), use the MATLAB function

```
uint8(255 * rand(3,3))
```

since 255 is the maximum value for an unsigned 8-bit integer. The other values are generated similarly.

With this setup, construct the send side of `udpreceiveA`.

Note that the width of the UDP packet to be sent is 75 bytes. The parameters used in the Pack block are **Input port datatypes** {'uint8', 'uint16', 'double'} and **Byte Alignment** 1.

For the Send block, set the **IP Address to send to** parameter to 192.168.0.11. This is the hypothetical address of the system that will run `udpreceiveA`. Set the **IP Port to send to** parameter to 25000 (picked arbitrarily). The sample time is set to 0.01.

Use this information to construct the receive end of `udpreceiveB`.

For setting up the Receive block, set **IP address to receive from** to 192.168.0.10 (the hypothetical address of the system that will run `udpreceiveB`). The **IP port to receive from** is set to 25000 (the same value as set in the **Remote IP port to send to** parameter of the Send block in `udpreceiveA`). The **Output port width** is set to 75, which is obtained from the output port width of the Pack block in `udpreceiveA`.

For the Unpack block, **Byte Alignment** is set to 1 and the **Output port datatypes** is set to {'uint8', 'int16', 'double'} from the Pack block in `udpreceiveA`. The **Output port dimensions** is set to {[3 3], 1, [2 4]} from the dimensions of the inputs to the Pack block in `udpreceiveA`.

Note that in `udpreceiveB`, the second output port of the Receive block is sent into a terminator. You can use this to determine when a packet has arrived. The same is true for the outputs of the Unpack block, which in a real model would be used in the model.

To construct the `udpreceiveB` to `udpreceiveA` side of the communication, follow an analogous procedure. The final `udpreceiveA` is shown below.

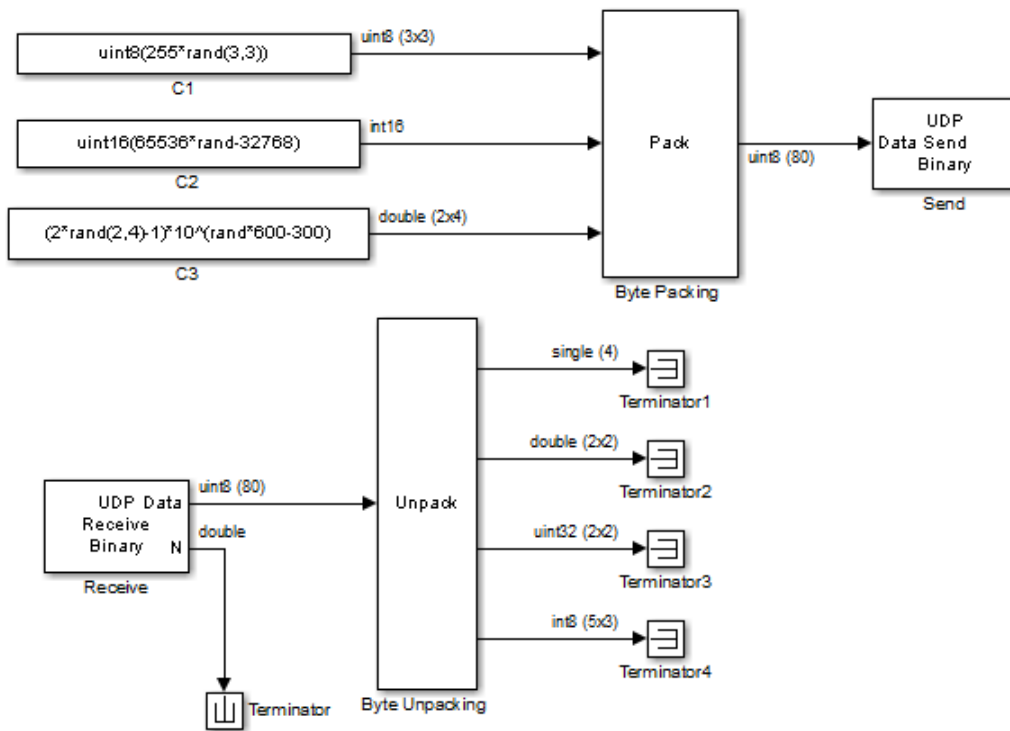

The following table lists the parameters in `udpreceiveA`.

Block	Parameter	Value
Receive	IP address	192.168.0.11
	IP port	25000
	Output port width	80
	Sample time	0.01
Unpack	Output port dimensions	{4,[2 2],[2 2],[5 3]}
	Output port data types	{'single','double','uint32','int8'}
	Byte alignment	2

The final `udpreceiveB` model is shown below.

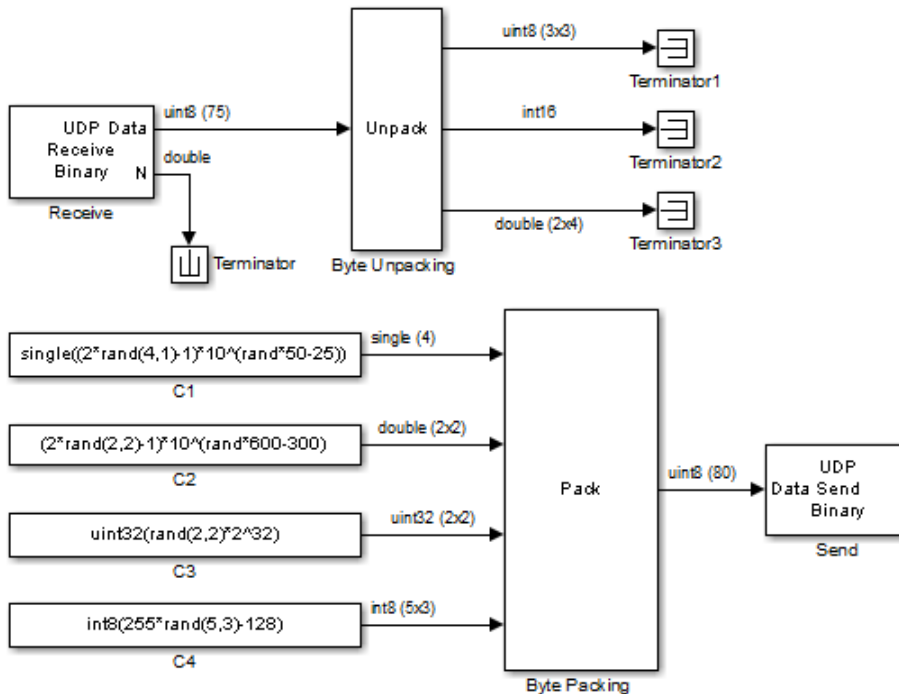

The following table lists the parameters in `udpreceiveB`.

Block	Parameter	Value
Pack	Input port data types	{'single', 'double', 'uint32', 'int8'}
	Byte alignment	2
Send	IP address	192.168.0.10
	IP port	25000
	Sample time	0.01

UDP Communication Setup

The infrastructure provided in the Simulink Real-Time Library for UDP communication consists mainly of two blocks — a Send block and a Receive block. These blocks are in the Simulink Real-Time Library, available from the Simulink Library under **Simulink Real-Time**. You can also access them from the MATLAB command line by typing

```
slrtlib
```

The blocks are located under the UDP heading in the library. The Send block takes as input a vector of type `uint8`, which it sends. This is limited to a length of about 1450 bytes (i.e., a 1 by 1450 vector). Similarly, the Receive block outputs a vector of `uint8`. To convert arbitrary Simulink data types into this vector of `uint8`, a Pack block is provided, while an Unpack block is provided to convert a vector of `uint8s` back into arbitrary Simulink data types.

You can have up to 32 UDP blocks in a model (Send and Receive blocks combined in arbitrary order).

The Simulink Real-Time block library includes a Byte Reversal block for communication with *big-endian* architecture systems. You do not need this block if you are communicating between 80x86-based computer systems running either the Simulink Real-Time or Microsoft® Windows software.

The blocks are set up to work both from within the Simulink environment and from a real-time application running under the Simulink Real-Time system. However, you must be careful when using a Simulink simulation and a real-time application to communicate, or when using two Simulink models. This is because a Simulink model is not a real-time model and can run several times faster or slower than a real-time application. The sample time of the send and receive blocks and the sample time of the Simulink model must be set so that the blocks can communicate.

Note the following:

- Your model cannot have two UDP Receive blocks configured with the same receive port, for example, the same receive port and different IP addresses.
- Your model cannot have two UDP Send blocks configured with the same send (not -1) port, for example, the send port and different IP addresses.

See “Target to Host Transmission using UDP” for an example of transmitting data between the development and target computers with the Simulink Real-Time system.

UDP and Variable-Size Signals

The Simulink Real-Time UDP sublibrary does not directly support variable-size signals. Of particular note, the UDP Send block input port accepts only fixed-size signals. This topic describes a workaround.

To send variable-size signals through UDP in a real-time application, select the **Allow variable length packets** parameter of the UDP Send block. This check box creates a second input for the block. With this second input, you can specify the number of elements of the fixed-size input signal to send through UDP.

Consider the following example. This example configures the MATLAB Function block to accept a variable-size signal and maps that signal to a fixed-size output signal. It also outputs the number of relevant elements. You can use the output of the fixed-size output signal and number of elements as the inputs of the UDP Send block.

- Create a MATLAB Function block to accept a variable-size input signal.
- Enter code like the following in the MATLAB Function block. In this code, the maximum size of the variable-size input signal is 9.

```
function [y,y_length] = fcn(u)
%#codegen
y = uint8(zeros(9,1));
y_length = length(u);
for a = 1:y_length
    y(a) = u(a);
end
```

- In the MATLAB Function Editor, select **Tools > Edit Data/Ports**. In **Ports and Data Manager**, select the data `u`, then select the corresponding **Variable size** check box.
- Select the data `y` and enter the size of the variable-size data input signal in the corresponding **Size** parameter. For this example, the size value is 9.
- Provide a variable-size signal source for the MATLAB Function block.

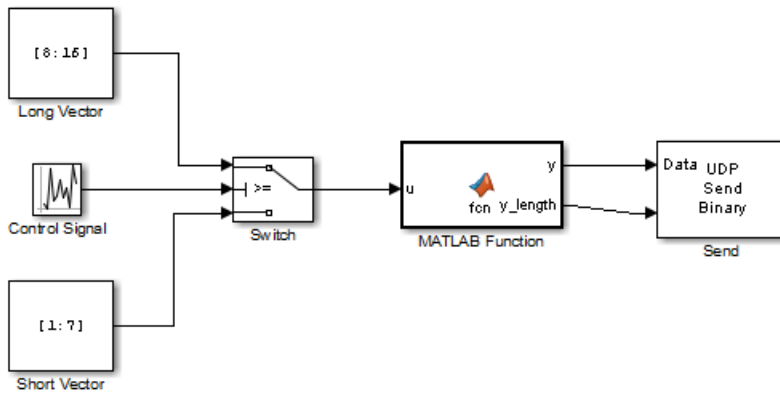

UDP I/O Blocks

UDP Receive

Receive UDP packets over the Ethernet link between development and target computers

Library

Simulink Real-Time Library for Legacy UDP

Description

The `UDP Receive` receives a byte stream (represented as a vector of `uint8` values) from the UDP board. Use the `Byte Unpacking` block to convert from the vector of `uint8` values to the signal data type.

IP fragmentation is not supported in Simulink Real-Time UDP blocks. The packet payload is limited to 1472 bytes (1500 bytes UDP packet size – 28 bytes combined packet header size).

Block Outputs

Name	Description
Data	Vector of <code>uint8</code> containing data received
N	Number of new bytes received, and otherwise 0

The default block behavior is to keep the previous output when there is no new data.

Block Parameters

IP address to receive from

Enter a valid IP address as a dotted decimal string. For example, `10.10.10.3`. You can also use a MATLAB expression that returns a valid IP address as a string.

Can be left with the default value of 0.0.0.0. This accepts all UDP packets from any accessible computer. If set to a specific IP address, only packets arriving from that IP address are received.

IP port to receive from

Receiver port that the block accepts data from. The other end of the communication sends data to the port specified here. This value must match the **Remote IP port to send to** parameter of the UDP Send block

Output port width

Width of the acceptable packets, in bytes. You can obtain this number when designing the other side (send side) of the communication. If you select Allow variable length packets, this parameter defines the maximum length of the message.

If **Allow variable length packets** is cleared, the block receives only packets of **Output port width** length. It discards the other packets.

Allow variable length packets

Select this check box to enable the reception of variable length messages. The value of **Output port width** defines the maximum length of the message. If this check box is selected, the first output port sends the actual data. If the port size is less than the size of the actual data, the block sends up to the allowed length of data. It discards the extra data. The UDP Receive block does not return the number of discarded bytes. The behavior of the second output port depends on what environment the block is in:

- If the block is in the Simulink Real-Time environment, the second output port sends the length of the original incoming message, *m*.
- If the block is in the Simulink environment, the second output port sends the size of the first output port +1.

If this check box is cleared (default), the first output port contains the actual data, and the second output port contains:

- 1, if the block receives the packet.
- 0, if the block does not receive the packet.

Sample time

You can set this parameter to -1 for an inheritable sample time, but you should set this parameter to some specific (small) value to eliminate chances of dropped packets. This is especially true when you are using a small base sample time.

See Also

Byte Unpacking | UDP Send

External Websites

- www.iso.org

UDP Send

Send UDP packets over the Ethernet link between development and target computers

Library

Simulink Real-Time Library for Legacy UDP

Description

The **UDP Send** block sends a byte stream (represented as a `uint8` vector) to the UDP board. Use the **Byte Packing** block to convert from the signal data type to a single vector of `uint8` values.

IP fragmentation is not supported in Simulink Real-Time UDP blocks. The packet payload is limited to 1472 bytes (1500 bytes UDP packet size – 28 bytes combined packet header size).

Block Inputs

Name	Description
Data	Vector of <code>uint8</code> containing data to send

Block Parameters

IP address to send to

Specify the IP address to send the packet. Enter a valid IP address as a dotted decimal string. For example, `10.10.10.3`. You can also use a MATLAB expression that returns a valid IP address as a string.

Remote IP port to send to

Specify the port to which to send the packet. This value must match the **IP port to receive from** parameter of the **UDP Receive** block

Use the following local IP port

Set this parameter to -1 (default) to allow the networking stack to automatically determine the local IP port that is used for sending. Otherwise, specify a particular port to send a packet from that port.

Allow variable length packets

Select this check box to enable the sending of variable length messages. Selecting this check box enables a second input port.

The width of the first signal entering the first input port specifies the maximum length of the input message. If this check box is selected, the first input port receives the actual data, and the second input port receives the actual length of the message.

If this check box is cleared, the block sends all the data each time.

Sample time

You can set this parameter to -1 for an inheritable sample time, but you should set this parameter to some specific (large) value to eliminate chances of dropped packets. This is especially true when you are using a small base sample time.

See Also

Byte Packing | UDP Receive

External Websites

- www.iso.org

Parallel Ports, PTP, SAE J1939, Shared Memory

Parallel Ports

Using Parallel Ports

In this section...

“Introduction” on page 18-2

“Using the Parallel Port as an Interrupt Source” on page 18-3

“Using Add-On Parallel Port Boards” on page 18-4

Introduction

Most target computers have a parallel port that you can use for a variety of devices. The Simulink Real-Time block library provides blocks that enable you to use the parallel ports of a target computer for digital input and output, and source interrupts.

Caution The parallel port is part of the motherboard on many computers. Be careful when configuring the port and when connecting external devices to the port. Incorrect connections to the port might damage your computer.

The Simulink Real-Time parallel port blocks assume that the connector to the parallel port has one 25-pin connector whose pins have the following designations:

- Eight data pins
- Five status pins
- Four control pins
- Eight ground pins

Function	Channel	1	2	3	4	5	6	7	8	Additional Pins
	Bit	0	1	2	3	4	5	6	7	
Digital Input		02	03	04	05	06	07	08	09	
Digital Output		02	03	04	05	06	07	08	09	
Digital Input (Status)		15	13	12	10	11				
Digital Output (Control)		01	14	16	17					
Interrupt										10

C0	1	14	C1
D0	2	15	S3
D1	3	16	C2
D2	4	17	C3
D3	5	18	Gnd
D4	6	19	Gnd
D5	7	20	Gnd
D6	8	21	Gnd
D7	9	22	Gnd
S6	10	23	Gnd
S7	11	24	Gnd
S5	12	25	Gnd
S4	13		

Using the Parallel Port as an Interrupt Source

To use the parallel port as an interrupt source, use pin 10 of the parallel port as the interrupt source. Configure the Simulink Real-Time model as follows:

- 1 Select **Simulation > Model Configuration Parameters**.
- 2 Under node **Code Generation**, select node **Simulink Real-Time Options**.
- 3 In the **Execution options** pane:
 - From **Execution mode**, select **Real-Time**.
 - From **Real-time interrupt source**, select the IRQ level (typically 7).
 - From **I/O board generating the interrupt**, select **Parallel_Port**.
 - In **PCI slot (-1: autosearch) or ISA base address**, enter the base address of the parallel port (typically 0x378).

If you want to use the **Async IRQ Source** block, you do not have to configure the model. Instead, you can set the **Async IRQ Source** block parameters as follows:

- **IRQ line number** — Select the IRQ level (typically 7).

- **I/O board generating the interrupt** — Select `Parallel_Port`.
- **PCI slot** — Enter the base address of the parallel port (typically `0x378`).

Using Add-On Parallel Port Boards

To use an add-on parallel port board with the parallel port blocks, configure the base address for the board as follows:

- 1 To get the base address of a board, in the MATLAB Command Window, call the function `SimulinkRealTime.target.getPCIInfo` with the `'verbose'` option. For example

```
tg = slrt;  
getPCIInfo(tg, 'verbose')
```

- 2 Identify the base address for the add-on parallel port board.
- 3 In your model, open the parallel port block and set the value of the **Base address** parameter to `Other`.

The **Alternate base address** parameter is displayed.

- 4 In the **Alternate base address** parameter, enter the base address you identified in step 2.
- 5 Configure the rest of the block as desired.

Note: You cannot use add-on parallel port boards as interrupt sources. You also cannot trigger the execution of a model with these boards.

Parallel Port Blocks

Parallel Port Digital Input

Parallel Port Digital Input block

Library

Simulink Real-Time Library for Parallel Port

Scaling Input to Output

I/O Module Input	Block Output Data Type	Scaling
TTL	Double (Format:8 1-bit Channels)	Double: TTL low = 0.0 TTL high = 1.0
	uint8 (Format:One 8-bit Port)	uint8: TTL low corresponding bit is clear TTL high corresponding bit is set

Block Parameters

Base address

Select a parallel port base address. This address depends on the target computer BIOS. From the list, select one of the following. If your base address is not one of the supplied standard base addresses, select **Other** and enter your base address in **Alternate base address**.

- 0x3bc
- 0x378
- 0x278
- Other

Alternate base address

Enter an alternate parallel port base address, in hexadecimal. This parameter appears only if you select **Other** for **Base address**. For example,

0x300

Format

From the list, select one of the following modes to specify how to treat data:

- **8 1-bit Channels**

Treats data as individual bits. Configures block to accept up to eight 1-bit channels.

- **One 8-bit Port**

Treats data as a single byte. Configures block to accept one 8-bit port.

Channels

Enter a vector of numbers between 1 and 8. This parameter appears only if you select **8 1-bit Channels** for **Format**. For example,

[1, 3]

Sample time

Enter the base sample time or a multiple of the base sample time (- 1 means sample time is inherited).

Parallel Port Digital Input Status Bits

Parallel Port Digital Input Status Bits block

Library

Simulink Real-Time Library for Parallel Port

Scaling Input to Output

I/O Module Input	Block Output Data Type	Scaling
TTL	Double (Format:5 1-bit Channels)	Double: TTL low = 0.0 TTL high = 1.0
	uint8 (Format:One 5-bit Port)	uint8: TTL low corresponding bit is clear TTL high corresponding bit is set

Block Parameters

Base address

Select a parallel port base address. This address depends on the target computer BIOS. From the list, select one of the following. If your base address is not one of the supplied standard base addresses, select **Other** and enter your base address in **Alternate base address**.

- 0x3bc
- 0x378
- 0x278
- Other

Alternate base address

Enter an alternate parallel port base address, in hexadecimal. This parameter appears only if you select **Other** for **Base address**. For example,

0x300

Format

From the list, select one of the following modes to specify how to treat data:

- **5 1-bit Channels**

Treats data as individual bits. Configures block to accept up to five 1-bit channels.

- **One 5-bit Port**

Treats data as a single byte. Configures block to accept one 5-bit port.

Channels

Enter a vector of numbers between 1 and 5. This parameter appears only if you select **5 1-bit Channels** for **Format**. For example,

[1, 3]

Sample time

Enter the base sample time or a multiple of the base sample time (- 1 means sample time is inherited).

Parallel Port Digital Output

Parallel Port Digital Output block

Library

Simulink Real-Time Library for Parallel Port

Scaling Output to Input

I/O Module Output	Block Input Data Type	Scaling
TTL	Double (Format:8 1-bit Channels)	Double: < 0.5 = TTL low > 0.5 = TTL high
	uint8 (Format:One 8-bit Port)	uint8: Bit clear = TTL low Bit set = TTL high

Block Parameters

Base address

Select a parallel port base address. This address depends on the target computer BIOS. From the list, select one of the following. If your base address is not one of the supplied standard base addresses, select **Other** and enter your base address in **Alternate base address**.

- 0x3bc
- 0x378
- 0x278
- Other

Alternate base address

Enter an alternate parallel port base address, in hexadecimal. This parameter appears only if you select **Other** for **Base address**. For example,

0x300

Format

From the list, select one of the following modes to specify how to treat data:

- **8 1-bit Channels**

Treats data as individual bits. Configures block to accept up to eight 1-bit channels.

- **One 8-bit Port**

Treats data as a single byte. Configures block to accept one 8-bit port.

Channels

Enter a vector of numbers between 1 and 8. This parameter appears only if you select **5 1-bit Channels** for **Format**. For example,

[1, 3]

Initial value vector

The initial value vector contains the initial voltage values for the output channels.

Enter a scalar or a vector that is the same length as the channel vector. If you specify a scalar value, that value is replicated as the initial value over the channel vector.

The channels are set to the initial values between the time the model is downloaded and the time it is started.

Final action vector

The final action vector controls the behavior of the channel at model termination.

Enter a scalar or a vector that is the same length as the channel vector. If you specify a scalar value, that setting is replicated over the channel vector. If you specify a value of 1, the corresponding channel is reset to the value specified in the initial value vector. If you specify a value of -1, the block sets the channel to the value specified in the **Final value vector** value for that channel. If you specify a value of 0, the channel remains at the last value attained while the model was running.

Final value vector

The final value vector contains the final value for each output channel. Enter a scalar or a vector that is the same length as the channel vector. If you specify a scalar value, that setting is replicated over the channel vector. If the **Final action vector** is -1, the block sets the channel to this value on model termination.

Sample time

Enter the base sample time or a multiple of the base sample time (- 1 means sample time is inherited).

Parallel Port Digital Output Control Bits

Parallel Port Digital Output Control Bits block

Library

Simulink Real-Time Library for Parallel Port

Scaling Output to Input

I/O Module Output	Block Input Data Type	Scaling
TTL	Double (Format:4 1-bit Channels)	Double: < 0.5 = TTL low > 0.5 = TTL high
	uint8 (Format:One 4-bit Port)	uint8: Bit clear = TTL low Bit set = TTL high

Block Parameters

Base address

Select a parallel port base address. This address depends on the target computer BIOS. From the list, select one of the following. If your base address is not one of the supplied standard base addresses, select **Other** and enter your base address in **Alternate base address**.

- 0x3bc
- 0x378
- 0x278
- Other

Alternate base address

Enter an alternate parallel port base address, in hexadecimal. This parameter appears only if you select **Other** for **Base address**. For example,

0x300

Format

From the list, select one of the following modes to specify how to treat data:

- **4 1-bit Channels**

Treats data as individual bits. Configures block to accept up to four 1-bit channels.

- **One 4-bit Port**

Treats data as a single byte. Configures block to accept one 4-bit port.

Channels

Enter a vector of numbers between 1 and 4. This parameter appears only if you select **4 1-bit Channels** for **Format**. For example,

[1, 3]

Initial value vector

The initial value vector contains the initial voltage values for the output channels.

Enter a scalar or a vector that is the same length as the channel vector. If you specify a scalar value, that value is replicated as the initial value over the channel vector.

The channels are set to the initial values between the time the model is downloaded and the time it is started.

Final action vector

The final action vector controls the behavior of the channel at model termination.

Enter a scalar or a vector that is the same length as the channel vector. If you specify a scalar value, that setting is replicated over the channel vector. If you specify a value of 1, the corresponding channel is reset to the value specified in the initial value vector. If you specify a value of -1, the block sets the channel to the value specified in the **Final value vector** value for that channel. If you specify a value of 0, the channel remains at the last value attained while the model was running.

Final value vector

The final value vector contains the final value for each output channel. Enter a scalar or a vector that is the same length as the channel vector. If you specify a scalar value, that setting is replicated over the channel vector. If the **Final action vector** is -1, the block sets the channel to this value on model termination.

Sample time

Enter the base sample time or a multiple of the base sample time (- 1 means sample time is inherited).

Precision Time Protocol

- “Precision Time Protocol” on page 20-2
- “Synchronize Timestamps Across Data-Gathering Network” on page 20-5
- “Data Acquisition and Data Analysis Example Description” on page 20-17
- “Precision Time Protocol Troubleshooting” on page 20-24
- “Prerequisites, Limitations, and Unsupported Features” on page 20-27

Precision Time Protocol

Measurement and control systems increasingly use distributed system technologies. To distribute measurement or control tasks over interconnected computing devices, such systems maintain a system-wide sense of time. Simulink Real-Time uses the Precision Time Protocol (PTP) to synchronize the PTP clock of each computer to a reference time. The PTP clock of a Simulink Real-Time target computer is the clock on the PTP network card.

PTP (IEEE 1588) is a protocol that synchronizes PTP clocks throughout a computer network. The current version of PTP (IEEE 1588-2008) describes a hierarchical master-slave architecture for clock distribution.

By design, this protocol is more accurate for local systems than the Network Time Protocol (NTP) and more robust than the Global Positioning System (GPS). On a local area network, the protocol achieves PTP clock accuracy in the submicrosecond range, making it suitable for distributed measurement. When you use this protocol to synchronize Simulink Real-Time applications across multiple target computers, it can synchronize execution to under $10\ \mu\text{s}$.

Suppose that you are designing a control system for a wind power plant. To determine the plant parameters, you attach sensors that acquire the data shown in the diagram.

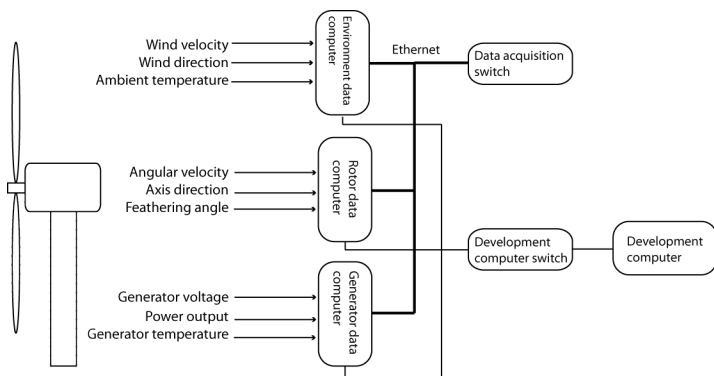

To record the data and timestamps, you connect the sensors to a set of data acquisition target computers. You interconnect the data acquisition computers through an Ethernet network and a switch that supports the PTP protocol (a PTP transparent clock or boundary clock). To access the data and timestamps, you connect the target computers

to a development computer through another Ethernet network and switch. On the development computer, you run MATLAB to do the data analysis, including:

- Sorting by time the data recorded on the different computers to analyze the event sequence over time.
- Filtering sensor data that have invalid (unsynchronized) timestamps.
- Integrating values of measured data collected at the same time from sensors connected to different computers.

To synchronize the target computer PTP clocks, you create a Simulink Real-Time model for each target computer. Each model uses the following PTP blocks:

- **IEEE 1588 Ethernet** — Run PTP protocol with Raw Ethernet as transport protocol. This block communicates with the corresponding blocks on the other target computers and determines the time offset that synchronizes them.
- **IEEE 1588 Read Parameter** — Output a Precision Time Protocol parameter value. Of the possible output values, you select `PTP time (nanosecond)`.

For debugging, you can configure a separate **IEEE 1588 Read Parameter** block to read other values, such as `Protocol state`.

- **IEEE 1588 Sync Execution** — Synchronize model execution to Precision Time Protocol clock. You can now make measurements at the same time step.
- **IEEE 1588 Sync Status** — Output the synchronization status of the Precision Time Protocol. When the value is `true`, the data timestamps are synchronized to the required precision.

As a best practice, for each model, you enclose the sensor block and the **IEEE 1588 Read Parameter** and **IEEE 1588 Sync Status** blocks in an **Atomic Subsystem** block. By using the **Atomic Subsystem** block, you bring the PTP timestamp as close as possible to the time of the data measurement.

Finally, you build and download the real-time applications to each target computer, run the applications, and collect and analyze the results at each valid timestamp. You use the results to design a control system for the wind power generator.

See Also

[Atomic Subsystem](#) | [IEEE 1588 Read Parameter](#) | [IEEE 1588 Ethernet](#) | [IEEE 1588 Sync Execution](#) | [IEEE 1588 Sync Status](#)

Related Examples

- “Synchronize Timestamps Across Data-Gathering Network” on page 20-5
- “Data Acquisition and Data Analysis Example Description” on page 20-17
- “IEEE® 1588™ Precision Time Protocol - Execution Synchronization”

More About

- “Prerequisites, Limitations, and Unsupported Features” on page 20-27

External Websites

- standards.ieee.org

Synchronize Timestamps Across Data-Gathering Network

This example shows a data acquisition target computer that transmits timestamped data to a second target computer that analyzes the data.

Required Products: Simulink®, Simulink Real-Time™

Other Requirements:

- One Windows® development computer with an Ethernet card.
- Two Speedgoat target computers.
- At least one Intel® 82574 Ethernet card on each target computer
- One Ethernet card on each target computer dedicated to communication between the development and target computers.
- One Ethernet switch.
- Four crossover Ethernet cables.

The real-time applications use Precision Time Protocol blocks to synchronize the Intel 82574 Ethernet card PTP clocks and the kernel clocks for each computer. You can log the PTP timestamps from both computers and use them to associate transmitted data with reference data.

Configure Hardware

Your Speedgoat target machines include at least two Ethernet cards installed, one of them an Intel 82574 Ethernet card. Use the Intel 82574 Ethernet card for the PTP network. Use the other to connect the two target computers through the Ethernet switch to the development computer. The network looks like this figure.

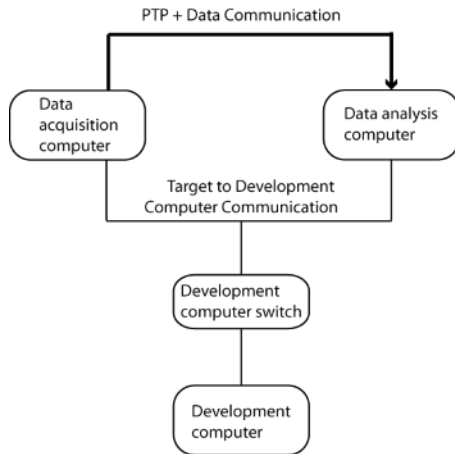

Required Information

To configure the network and your models for this example, collect the following information:

- Identifiers for the target computers
- *PTP card*: Device name / PCI bus and slot numbers / MAC address that you assign to the PTP card that is transmitting non-PTP data
- *COM card*: Device name / PCI bus and slot numbers / Ethernet index of the card

You can find the built-in MAC address of the PTP card from a source such as a bill of materials or a label on the hardware. You can find the device name and the PCI bus and slot numbers by using `SimulinkRealTime.target.getPCIInfo`. You can find the Ethernet index of the communication card by using `SimulinkRealTime.getTargetSettings`.

Example Information

TargetPC1

- *PTP card*: Device name: Intel 82574L / PCI bus: 5 / PCI slot: 0 / MAC Address: [EEPROM}
- *COM card*: Device name: Intel 82579LM / Ethernet index: 0 / PCI bus: 0 / PCI slot: 25 / MAC address: N/A

TargetPC2

- *PTP card*: Device name: Intel 82574L / PCI bus: 0 / PCI slot: 52 / MAC Address: 68:05:CA:31:B9:EF
- *COM card*: Device name: Intel 82541GI_LF / Ethernet index: 0 / PCI bus: 16 / PCI slot: 4 / MAC address: N/A

Hardware Configuration

- 1 Connect an Ethernet cable between the PTP card in **TargetPC1** and the PTP card in **TargetPC2**. This connection creates the PTP network. To configure the IEEE 1588 Ethernet blocks in the two real-time applications, you must have the PCI bus and PCI slot of these cards.
- 2 Connect an Ethernet cable from the Comm card in **TargetPC1** to the Ethernet switch.
- 3 Connect an Ethernet cable from the Comm card in **TargetPC2** to the switch.
- 4 Connect an Ethernet cable from the switch to the development computer. These connections complete the communication network between the development computer and the target computers.
- 5 Start the two target computers. Use `slrtexplr` to connect to them. If you cannot establish communication with a target computer, verify the Ethernet index assigned to the communication port.

Configure Real-Time Applications

In this example, the system contains two real-time applications running on separate target computers. The data acquisition application transmits PTP and non-PTP data to the data analysis application. To configure the data acquisition application, you must have the MAC address of the PTP card that is installed in the data analysis target computer. The data analysis application transmits only PTP data to the data acquisition application. To configure the data analysis application, you can use the MAC address stored in the EEPROM of the PTP card in the data acquisition target computer.

Configure Data Acquisition Application

To configure this application, first perform the steps in Configure Hardware. Collect the PCI bus, PCI slot, and role of the Ethernet cards installed in the target computers.

The data acquisition application is `ex_ptp_sync_src` [`<matlab: open_system(docpath(fullfile(docroot,'toolbox','xpc','examples','ex_ptp_sync_src')))>`]. It runs on **TargetPC1**. To configure the application:

Set Configuration Parameters

- 1 Open `ex_ptp_sync_src`.
- 2 In the Configuration Parameters dialog box, open the **Solver** pane.
- 3 Verify that **Type** is **Fixed-step**.
- 4 Verify that **Fixed-step size (fundamental sample time)** is set to an explicit value and not to `auto` (best practice). Use the same sample time as in the data analysis application.
- 5 Verify that **Allow tasks to execute concurrently on target** is set.
- 6 Take the defaults for the other settings.
- 7 Open the Simulink Real-Time Options pane.
- 8 Verify that **Build for default target computer** is cleared.
- 9 Verify that **Specify target computer name** is `TargetPC1`.
- 10 Verify that **Execution mode** is **Real-Time**.
- 11 Take the defaults for the other settings.

Configure PTP Blocks

- 1 Open the IEEE 1588 Ethernet block
- 2 Open the General pane.
- 3 From the information for the TargetPC1 PTP card, enter the values 5 and 0 for **PCI bus** and **PCI slot**.
- 4 Verify that the IEEE 1588 Ethernet **Sample time** value is a multiple of the **Fixed-step size (fundamental sample time)** value.
- 5 Verify that **Sample time** has the same value as in the data analysis model.
- 6 Open the **Network parameters** pane.
- 7 From the information for the TargetPC1 PTP card, in the **Source MAC address** box, select EEPROM.
- 8 Verify that **Destination MAC address** is **Standard PTP multicast**.
- 9 Open the **Clock parameters** pane.
- 10 Verify that **Timescale (epoch)** is **PTP (1970-01-01)**.
- 11 Verify that **Delay measurement mechanism** is **Request-response**.
- 12 Set the **Slave only** check box. This setting prevents the software from making this node the master PTP clock node.

- 13 Open the **Time intervals** pane.
- 14 Verify that **Announce interval (second)**, **Sync interval (second)**, and **Min delay or pdelay request interval (second)** are at least three times the **Sample time** value.
- 15 Verify that the intervals are integral multiples of **Sample time**.
- 16 Verify that the intervals have the same settings as in the data analysis model.
- 17 In the remaining top-level PTP blocks, verify that the **Sample time** value matches that in the IEEE 1588 Ethernet block.
- 18 Open PTP Clock-Data Subsystem. For each block in the subsystem, verify that the **Sample time** value matches that in the IEEE 1588 Ethernet block.

Configure Data Communication Blocks

- 1 From the information for the TargetPC2 PTP card, in the Create Ethernet Packet block dialog box, set **Destination MAC** to `macaddr('68:05:CA:31:B9:EF')`.
- 2 Set **EtherType (use 0 for length)** to `hex2dec('0010')`. Using this type distinguishes the data-specific messages from the PTP-specific messages, which use the same Ethernet card.
- 3 In the Ethernet Tx block, verify that the **Sample time** value matches that in the IEEE 1588 Ethernet block.
- 4 Save the updated model in your working folder. You cannot build and run a real-time application in the examples folder.

Configure Data Analysis Application

To configure this application, first perform the steps in Configure Hardware. Collect the PCI bus, PCI slot, and role of the Ethernet cards that are installed in the target computers. To configure the PTP card in the data analysis target computer, use the MAC address that you specified in the Create Ethernet Packet block of the data acquisition application.

The data analysis application is `ex_ptp_sync_sink` [`<matlab:open_system(docpath(fullfile(docroot,'toolbox','xpc','examples','ex_ptp_sync_sink')))>`]. It runs on TargetPC2. To configure the application:

Set Configuration Parameters

- 1 Open `ex_ptp_sync_sink`.

- 2 In the Configuration Parameters dialog box, open the **Solver** pane.
- 3 Verify that **Type** is **Fixed-step**.
- 4 Verify that **Fixed-step size (fundamental sample time)** is set to an explicit value (best practice) and not to **auto**. Use the same sample time as in the data acquisition application.
- 5 Verify that **Allow tasks to execute concurrently on target** is set.
- 6 Take the defaults for the other settings.
- 7 Open the **Simulink Real-Time Options** pane.
- 8 Verify that **Build for default target computer** is cleared.
- 9 Verify that **Specify target computer name** is **TargetPC2**.
- 10 Verify that **Execution mode** is **Real-Time**.
- 11 Take the defaults for the other settings.

Configure PTP Blocks

- 1 Open the IEEE 1588 Ethernet block.
- 2 Open the **General** pane.
- 3 From the information for the TargetPC2 PTP card, enter the values 52 and 0 for **PCI bus** and **PCI slot**.
- 4 Verify that the IEEE 1588 Ethernet Sample time value is a multiple of the Fixed-step size (fundamental sample time) value.
- 5 Verify that Sample time has the same value as in the data acquisition IEEE 1588 Ethernet block.
- 6 Open the **Network parameters** pane.
- 7 In the **Source MAC address** box, select **Specify**.
- 8 From the information for the TargetPC2 PTP card, in the **Specify source MAC address** text box, enter `macaddr('68:05:CA:31:B9:EF')`. You can enter an arbitrary MAC address in this box, provided it is unique in the PTP network.
- 9 Verify that **Destination MAC address** is **Standard PTP multicast**.
- 10 Open the **Clock parameters** pane.
- 11 Verify that **Timescale (epoch)** is **PTP (1970-01-01)**.
- 12 Verify that **Delay measurement mechanism** is **Request-response**.

- 13 Verify that **Slave only** is cleared. This setting allows the software to make this node the master PTP clock node.
- 14 Open the **Time intervals** pane.
- 15 Verify that **Announce interval (second)**, **Sync interval (second)**, and **Min delay or pdelay request interval (second)** are at least three times the Sample time value.
- 16 Verify that the intervals are integral multiples of **Sample time**.
- 17 Verify that the intervals have the same settings as in the data acquisition model.
- 18 In the remaining top-level PTP blocks, verify that the **Sample time** value matches that in the IEEE 1588 Ethernet block.
- 19 Open PTP Clock-Data Subsystem. For each block in the subsystem, verify that the **Sample time** value matches that in the IEEE 1588 Ethernet block.

Configure Data Communication Blocks

- 1 Open PTP Clock-Data Subsystem
- 2 Open the Ethernet Rx block.
- 3 Open the **Rx** pane and verify that the **Sample time** value matches that in the IEEE 1588 Ethernet block.
- 4 Open the **Filter** pane.
- 5 Verify that **Filter criteria** is Specify types to match.
- 6 Verify that **Receive these types (vector of types 0-65535)** is `[hex2dec('0010')]`.
- 7 Save the updated model in your working folder. You cannot build and run a real-time application in the examples folder.

Build, Download, and Run Real-Time Applications

In this example, the data acquisition application builds and is downloaded to TargetPC1. The data analysis application builds and is downloaded to TargetPC2. To run these applications, first perform the steps in Configure Real-Time Applications. MATLAB® and Simulink Real-Time Explorer must be running in your working folder.

Build, download, and run the applications:

- 1 Start TargetPC1 and TargetPC2.

- 2 In the Explorer Targets pane, connect to TargetPC1 and TargetPC2.
- 3 In your working folder, open `ex_ptp_sync_src` and `ex_ptp_sync_sink`.
- 4 Build and download `ex_ptp_sync_src` to TargetPC1.
- 5 Build and download `ex_ptp_sync_sink` to TargetPC2.
- 6 In the Explorer **Applications** pane, for TargetPC1/`ex_ptp_sync_src` and TargetPC2/`ex_ptp_sync_sink`, change the property **Stop Time** to Inf.
- 7 In the Explorer **Applications** pane, start `ex_ptp_sync_src` and `ex_ptp_sync_sink`.
- 8 For both applications, waveform data starts streaming in the target scopes labeled **Data**. However, the timestamps displayed as signal **Time** are not initially valid. The two applications go through the following sequence of **Sync Status** and **State** values:

1. Initialization:

- `ex_ptp_sync_src` State → 4 (LISTENING)
- `ex_ptp_sync_src` Sync Status → 0 (not synchronized)
- `ex_ptp_sync_sink` State → 4 (LISTENING)
- `ex_ptp_sync_sink` Sync Status → 0 (not synchronized)

2. Master allocation and synchronization

- `ex_ptp_sync_sink` State → 6 (MASTER)
- `ex_ptp_sync_sink` Sync Status → 1 (synchronized)

3. Slave allocation and synchronization

- `ex_ptp_sync_src` State → 9 (SLAVE)
- `ex_ptp_sync_src` Sync Status → 1 (synchronized)

For the data acquisition node (the slave node), the final state looks like this figure.

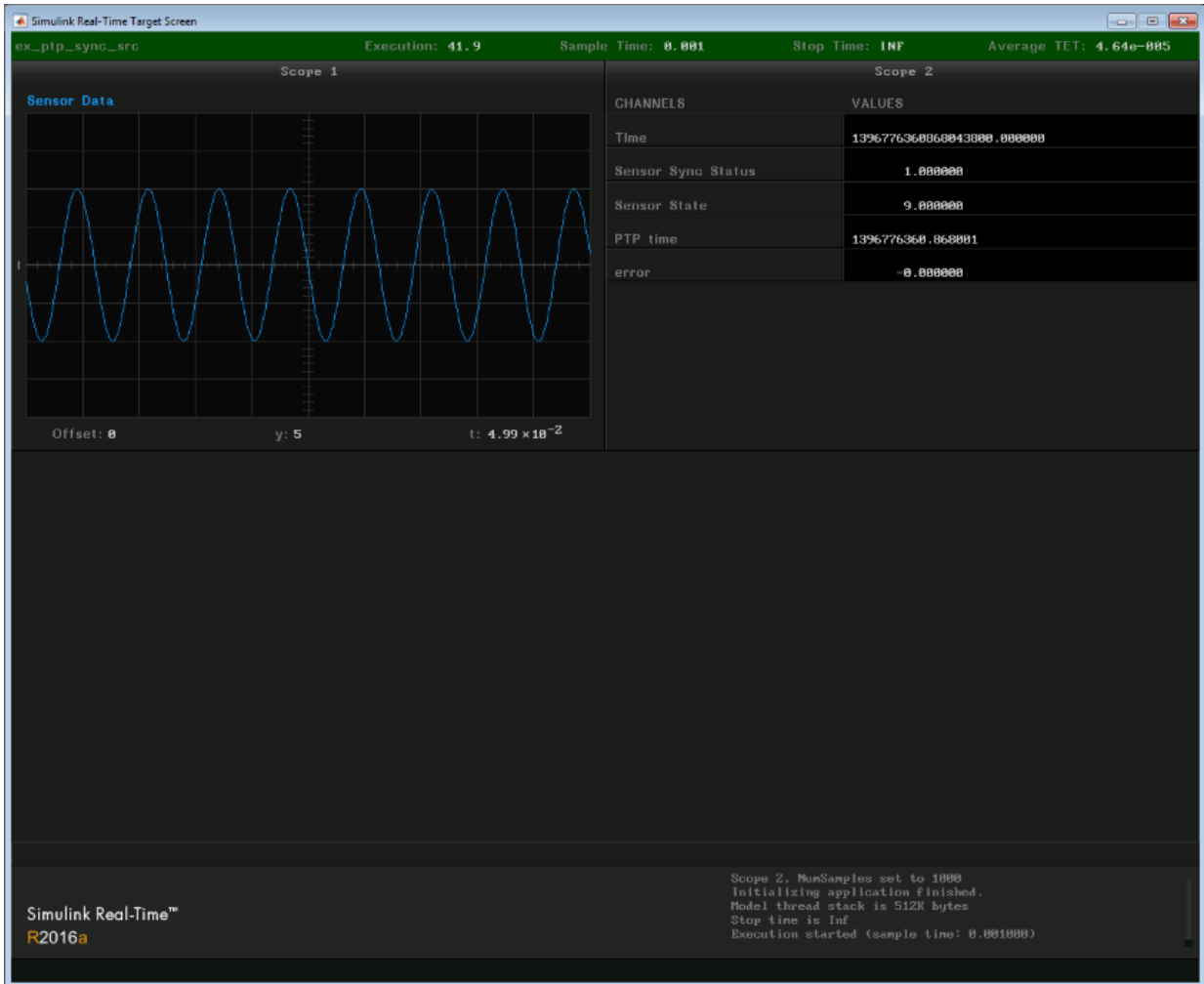

For the data analysis node (the master node), the final state looks like this figure.

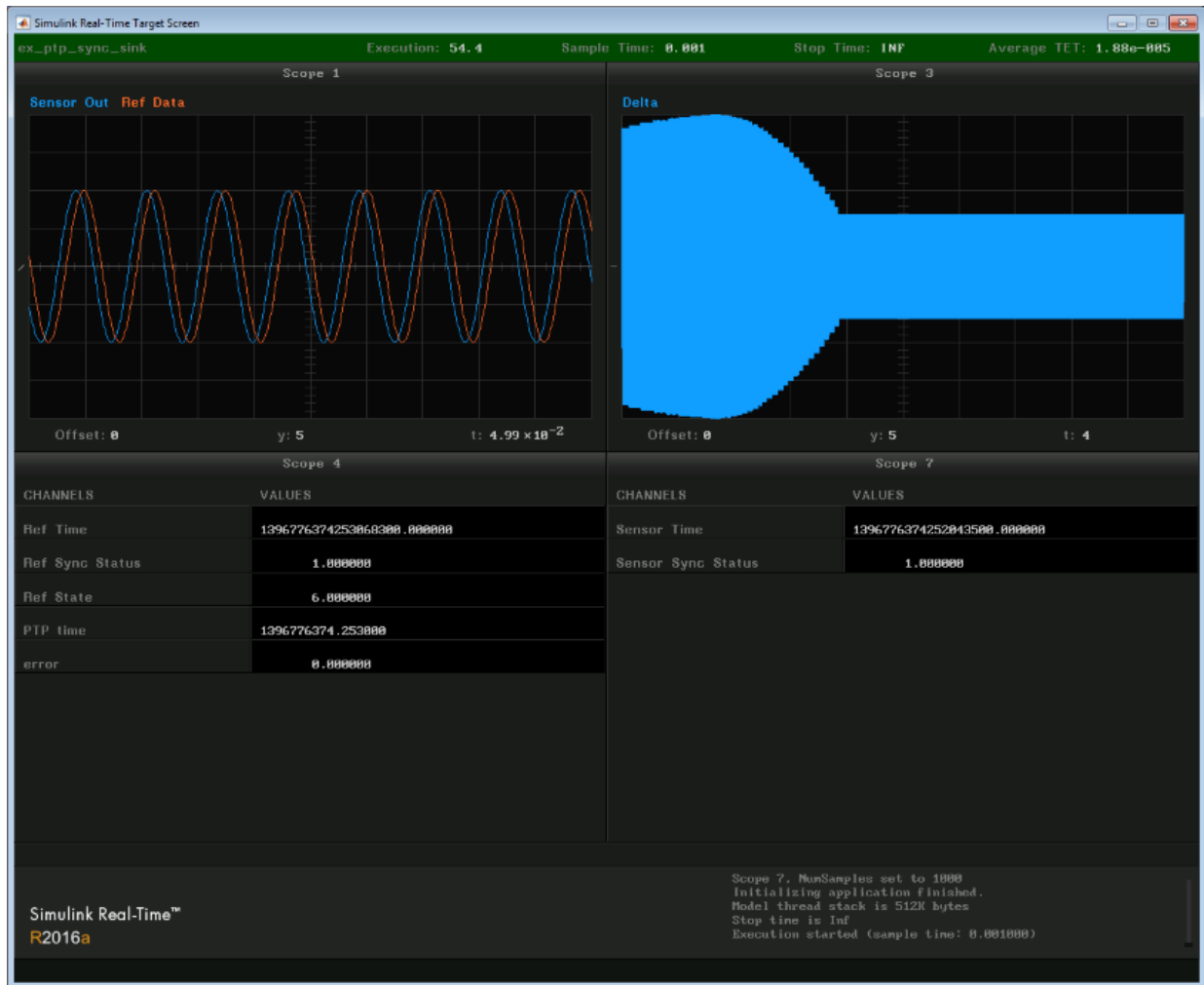

For this example, the sensor and reference Sine Wave blocks are set to the same frequency and amplitude, but start at arbitrary times. The difference in start time causes a phase difference between the sine waves. The phase difference appears on the Delta scope as a waveform that settles to a constant amplitude.

The phase difference is constant because the IEEE 1588 Sync Execution blocks synchronize the kernel clocks on the two target computers. If you do not include these

blocks, the kernel clocks of the two target computers drift apart. As a result, the Delta waveform shows a beat frequency.

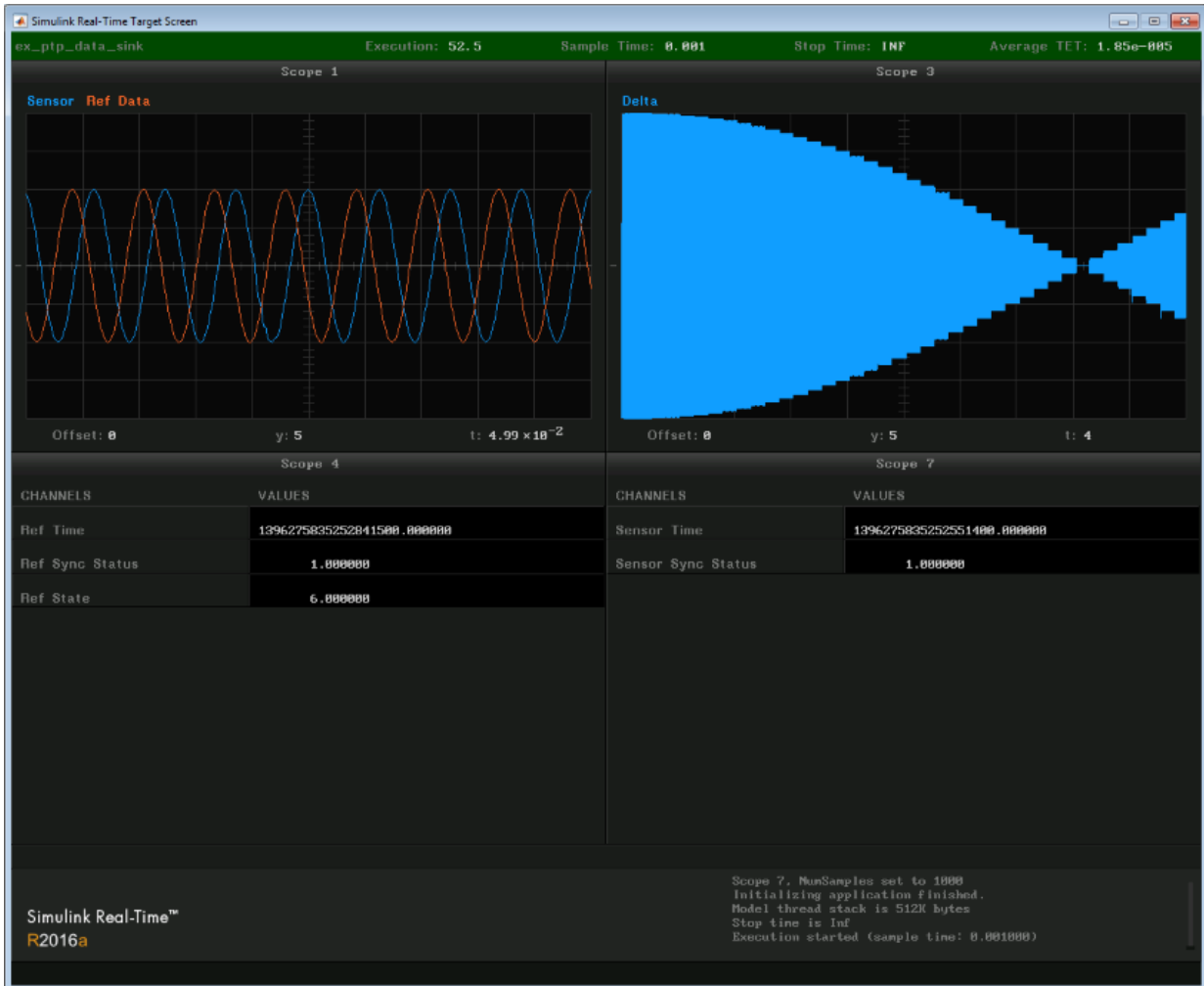

With the IEEE 1588 Sync Execution block, you can make measurements across multiple target computers at a synchronized time step. However, the kernel interrupt clock

controller can shorten some time steps up to 10% of the fundamental sample time, resulting in a CPU overload.

See Also

[ex_ptp_data_sink](#) | [ex_ptp_data_src](#) | [ex_ptp_sync_sink](#) | [ex_ptp_sync_src](#) | [IEEE 1588 Sync Execution](#) | [IEEE 1588 Ethernet](#) | [IEEE 1588 Read Parameter](#) | [IEEE 1588 Sync Status](#)

Related Examples

- “Data Acquisition and Data Analysis Example Description” on page 20-17

More About

- “Precision Time Protocol” on page 20-2

Data Acquisition and Data Analysis Example Description

This example features a data acquisition target computer that transmits timestamped sensor data to a second target computer. The second target computer processes the sensor data and displays the data and the difference between the sensor data and reference data. Both target computers connect to a development computer. The development computer runs Simulink and Simulink Real-Time Explorer to build, download, and run real-time applications on each target computer. The real-time applications use Precision Time Protocol (PTP) blocks to synchronize the PTP clocks and kernel clocks on each computer.

In this section...

“Data Acquisition Application” on page 20-17

“Data Analysis Application” on page 20-20

Data Acquisition Application

The data acquisition application is a PTP slave node that acquires data from a sensor that is represented by a `Sine Wave` block. The application transmits the sensor data to the data analysis application.

Top-Level Model

The PTP initialization block and the blocks that create and transmit the Ethernet packet are in the top-level model:

- `IEEE 1588 Ethernet` — Configures the PTP network card clock as a slave clock.
- `IEEE 1588 Read Parameter` — Shows when the PTP clock has been allocated as a slave clock (value 9). Configured as `Read Protocol state`.
- `IEEE 1588 Sync Execution` — Aligns the kernel clocks across multiple target computers. The block output shows the difference between the PTP time at the real-time interrupt and the nearest PTP time that is a multiple of the fundamental sample time.
- `Byte Packing` — Packs the sensor data, timestamp, and synchronization status into an Ethernet packet.
- `Create Ethernet Packet` — Addresses the Ethernet packet to the MAC address of the data analysis application.

- **Ethernet Tx** — Transmits the Ethernet packet to the data-analysis target computer.

The **Ethernet Tx** block sends data packets through the same Ethernet connection as the PTP blocks use to send PTP messages. To distinguish data packets from PTP messages, the model assigns to the data packets an Ethernet type (`hex2dec('0010')`) that is different from the default Ethernet type of PTP packets (`hex2dec('88F7')`).

- **Output** — For data logging purposes, the top-level model propagates the major signals to **Output** blocks.

For debugging purposes, the top-level model includes two real-time **Scope** blocks:

- **Sensor Data** — Displays the sensor data in a graphic scope.
- **Sensor PTP Data** — Displays the PTP time, PTP synchronization status, PTP state, and synchronization delta of the data acquisition model.

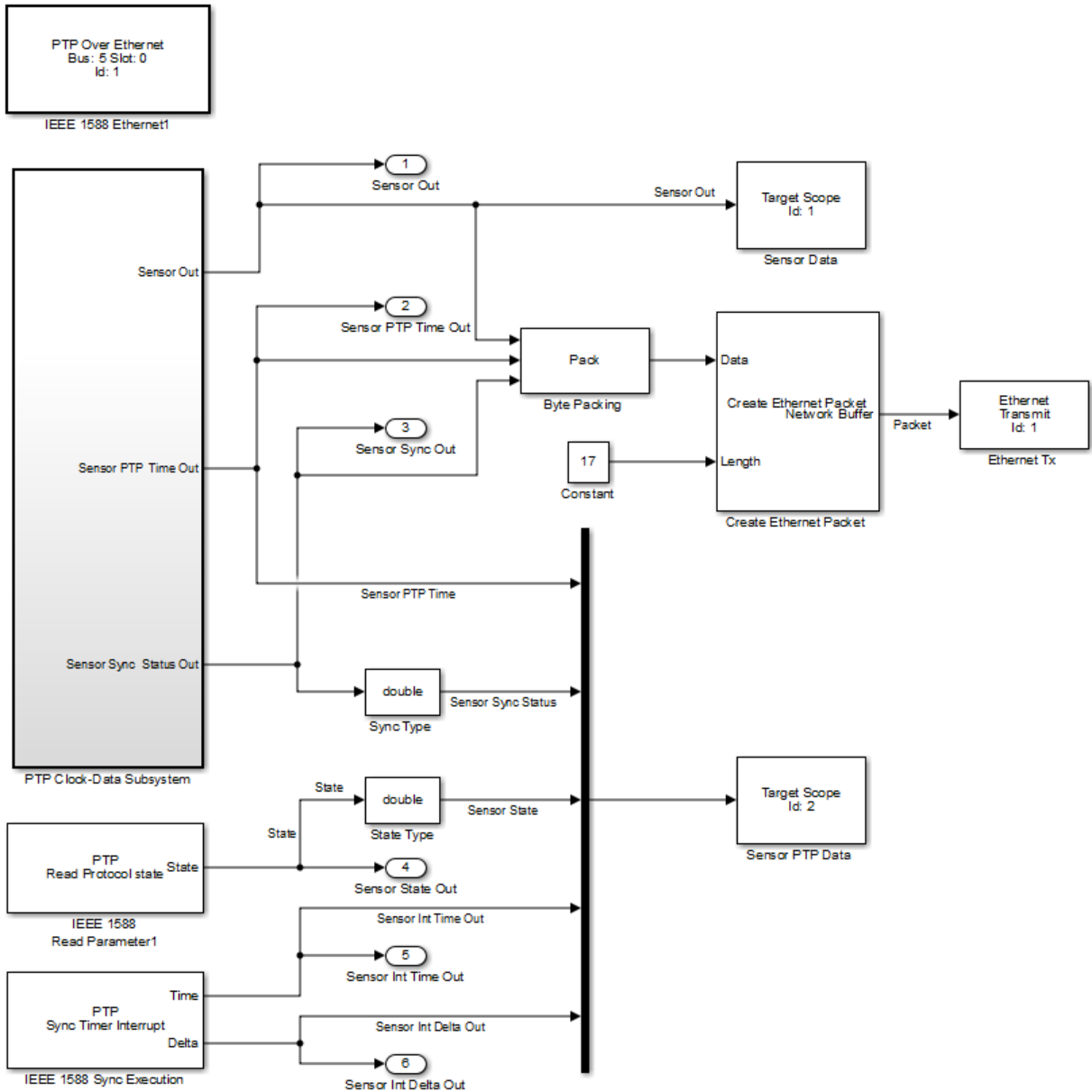

Atomic Subsystem

The PTP timestamp must align as closely as possible with the data source. For better alignment, the model wraps the sensor data block and the lower-level PTP blocks in an atomic subsystem:

- **Sine Wave** — Represents sensor data.
- **IEEE 1588 Read Parameter** — Generates the timestamp, configured as **PTP Time (nanosecond)**.
- **IEEE 1588 Sync Status** — Generates the synchronization status. When the PTP clock is synchronized with the master PTP clock, the block output becomes 1.

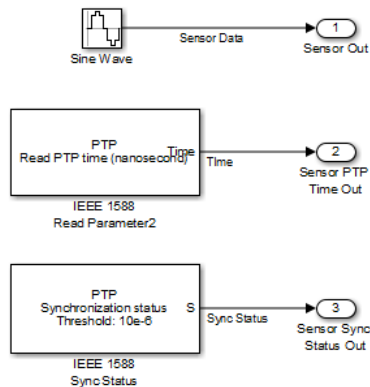

Data Analysis Application

The data analysis application is a PTP master node that gets sensor data from an emulator, a **Sine Wave** block. The application gets reference data from an emulator, a **Sine Wave** block, and sensor data from an **Ethernet Rx** block. The application calculates the difference between the reference data and the sensor data.

Top-Level Model

The PTP initialization block and the blocks that receive and process the data are in the top-level model:

- **IEEE 1588 Ethernet** — Configures the PTP network card clock as a master clock.

- **IEEE 1588 Read Parameter** — Shows when the PTP clock has been allocated as a master clock (value 6). Configured as `Read Protocol` state.
- **IEEE 1588 Sync Execution** — Aligns the kernel clocks across multiple target computers. The block output shows the difference between the PTP time at the real-time interrupt and the nearest PTP time that is a multiple of the fundamental sample time.
- **Extract Ethernet Packet** — Extracts the Ethernet packet that is carrying the sensor data.
- **Byte Unpacking** — Unpacks the sensor data, timestamp, and synchronization status from the Ethernet packet.
- **Sum** — Calculates the difference between the sensor data and the reference data.

The **Sum** block provides input data for further processing. For example, you can plot the sensor data, reference data, and difference against the timestamp to assess the real-time behavior. You can also feed the difference data back through a control system to change an actuator setting at the data acquisition site.

- **Output** — For data logging purposes, the top-level model propagates the major signals to **Output** blocks.

For debugging purposes, the top-level model includes four real-time **Scope** blocks:

- **Ref/Sensor Data** — Displays the reference data and the sensor data together in a graphic scope.
- **Delta** — Displays the difference between the reference data and the sensor data in a graphic scope.

The **Delta** scope is configured with a long sample time. It captures long-period differences between the sensor and reference data. If the frequency, phase, and amplitude differences are constant, the scope displays a rectangular area. If the differences are periodic, the scope displays a beat frequency.

- **Ref PTP Data** — Displays the PTP time, PTP synchronization status, PTP state, and synchronization delta of the data analysis model.
- **Sensor PTP Data** — Displays the PTP time, PTP synchronization status, and synchronization delta of the data acquisition model.

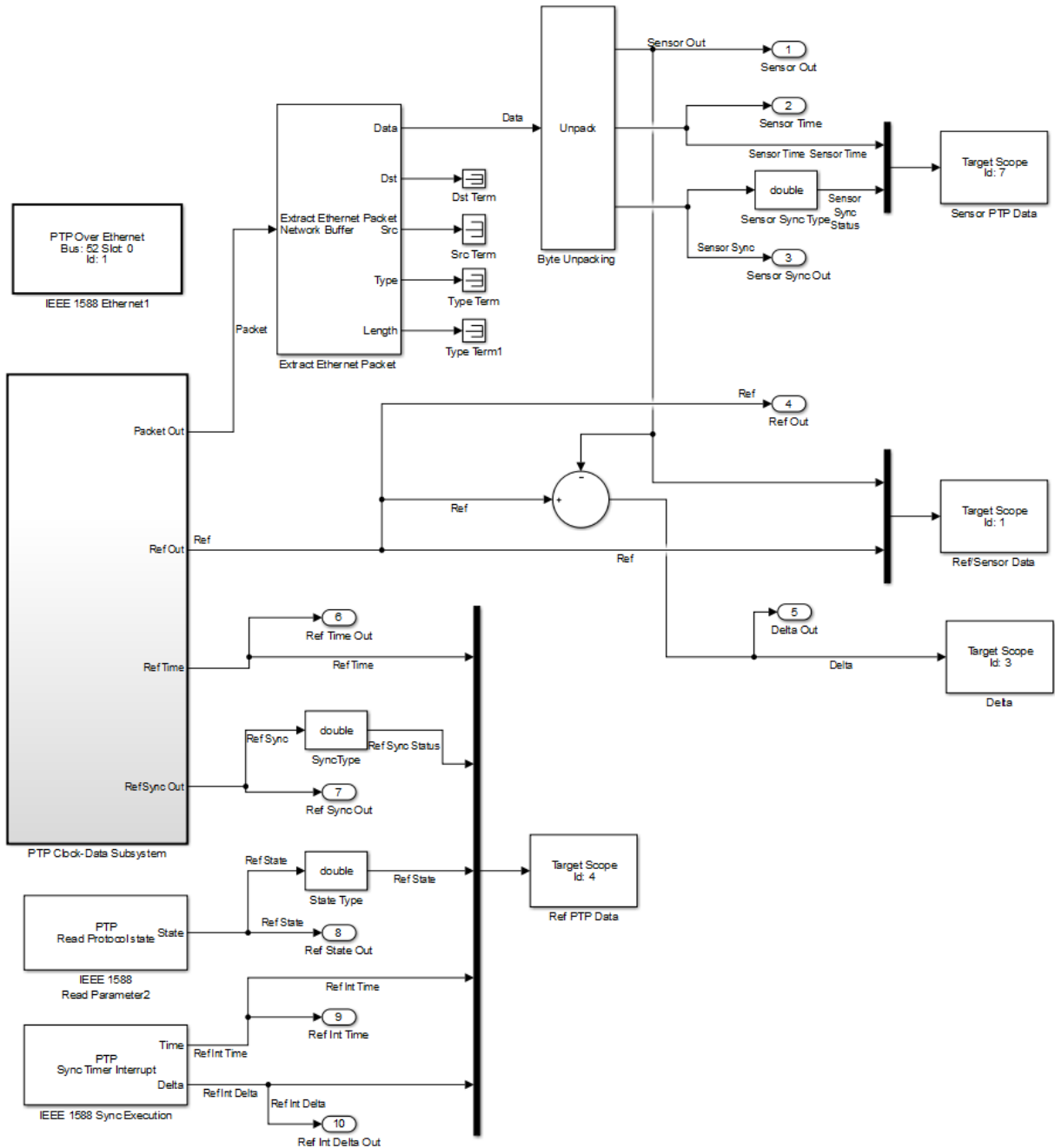

Atomic Subsystem

The PTP timestamp must align as closely as possible with the Ethernet receiver. For better alignment, the model wraps the blocks representing the reference data source and the lower-level PTP blocks in an atomic subsystem:

- **Sine Wave** — Represents reference data.
- **IEEE 1588 Read Parameter** — Generates the timestamp, configured as PTP Time (nanosecond).
- **IEEE 1588 Sync Status** — Generates the synchronization status. When the PTP clock is synchronized with the master PTP clock, the block output becomes 1.
- **Ethernet Rx** — Receives sensor data from the acquisition target computer. The configured block filters out all packets except packets of Ethernet type `hex2dec('0010')`. The default Ethernet type of PTP packets is `hex2dec('88F7')`.

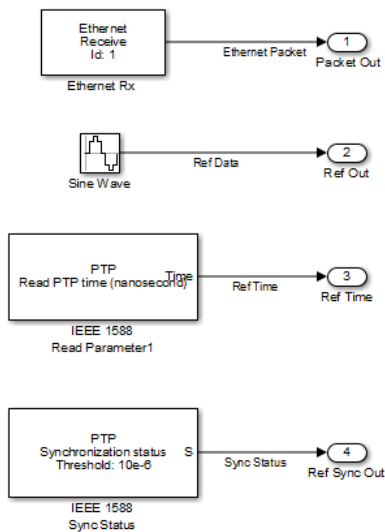

See Also

[ex_ptp_sync_sink](#) | [ex_ptp_sync_src](#) | [IEEE 1588 Sync Execution](#) | [IEEE 1588 Ethernet](#) | [IEEE 1588 Read Parameter](#) | [IEEE 1588 Sync Status](#)

Precision Time Protocol Troubleshooting

To troubleshoot your model, first familiarize yourself with the PTP standard, and then with the specialized requirements of the Simulink Real-Time implementation.

In this section...

“Modeling” on page 20-24

“Accuracy” on page 20-25

“Faulty States” on page 20-25

Modeling

- Configure all PTP nodes in a network with the same **Delay measurement mechanism**. If you configure a slave node with a different setting from the master node, the slave node enters the FAULTY state
- Configure all PTP nodes in a network with the same **Timescale** or **Arbitrary timescale epoch** value. If you configure the master and slave nodes with differing timescales, the representation of time in time-of-day format differs for the two nodes.
- Configure all nodes in the PTP networks with the same **Announce interval** and **Announce receipt timeout**. Differing values of these parameters in a PTP network can lead to unpredictable behavior.
- Avoid using inherited sample time everywhere in your model. Inherited sample time occurs throughout your model when you make the following settings:
 - **Fixed step size** → `auto` in the Configuration Parameters dialog box
 - **Sample time** → `-1` in all of the blocks of your model.

The sample time that Simulink calculates can be greater than the PTP message transmission intervals, resulting in an unusable model.

- The PTP configuration subsystems include configuration blocks for the associated transport protocol. If you use a separate Ethernet card for data transmission, include a separate network configuration block. Assign it a **Device ID** different from the one already in use by the PTP configuration block. Multiple network configuration blocks with the same **Device ID** cause a build error.
- The PTP Over Ethernet block creates PTP messages with **Ether type** set to `hex2dec('88F7')`. To use the same Ethernet card for PTP as for data transmission:

- In the **Create Ethernet Packet** block, set **Ether type** to a nonzero value that is different from `hex2dec('88F7')` (for example, `hex2dec('0010')`).
- In the **Ethernet Rx** block, set **Filter criteria** to **Specify types to match**. Set **Receive these types** to the value that you set in the **Create Ethernet Packet** block (for example, `[hex2dec('0010')]`).
- If you include more than one slave node in the network, configure the master node to use the standard PTP multicast address for transmitting messages. The master node must transmit the same synchronization message to all the slaves.
- Using the **IEEE 1588 Sync Execution** block to make measurements across multiple target computers at the same simulation step can lead to a CPU overload. Also, the kernel interrupt clock controller can shorten some time steps up to 10% of the model fundamental sample time.

If you get CPU overloads, consider decreasing the value of the **Proportional gain** parameter of the **IEEE 1588 Sync Execution** block or increasing the sample time of your real-time application.

Accuracy

- The synchronization accuracy depends upon the value of **Sync interval**. The smaller the value, the more accurate the synchronization. If your model fails to meet your required synchronization accuracy, try decreasing the value of **Sync interval**.
- If two PTP models with differing fundamental sample times use the **IEEE 1588 Sync Execution** block, their execution is synchronous at a PTP time equal to the least common multiple of the two rates.

Faulty States

- When a slave node enters the **FAULTY** state, look for one of the following conditions:
 - The slave node is configured with a different **Delay measurement mechanism** setting from the master node setting.
 - The slave node model sample time setting is greater than the master node **Sync interval** setting.
 - The slave node **Announce interval** setting is shorter than the master node **Announce interval** setting.

- The slave is not receiving a response from the master to delay request messages sent by the slave. This behavior occurs, for example, if the slave node is configured to use a delay measurement mechanism setting different from the master node setting.
- If the master node fails to read a required timestamp from the Ethernet card due to contention for the timestamp register, the transmission can fail. After a master node fails five consecutive times to transmit a `Follow_Up`, `Delay_Resp`, `Pdelay_Resp`, or `Pdelay_Resp_Follow_Up` message to its slave nodes, it enters the FAULTY state. Try the following:
 - Reduce the number of slave nodes in the network.
 - Shorten the sample time for the subsystem that represents the master node. The master node cycles through the slave messages faster and reads the timestamp register more often.
 - Increase the **Min delay or pdelay request interval** of the slave nodes. The slave nodes generate messages less often.
 - Connect a peer-to-peer transparent PTP clock between the master and slave nodes. Set **Delay measurement mechanism** to `Peer-delay` for all of the nodes. The peer-to-peer transparent PTP clock has a separate timestamp register for each port, taking the load off the master node.

For more information, see IEEE Std 1588-2008 Clause 10.

More About

- “Prerequisites, Limitations, and Unsupported Features” on page 20-27

External Websites

- standards.ieee.org

Prerequisites, Limitations, and Unsupported Features

The Simulink Real-Time implementation of PTP enforces specific requirements and limitations.

In this section...

“Prerequisites” on page 20-27

“Limitations” on page 20-27

“Unsupported Features” on page 20-29

Prerequisites

- PTP functionality is available only with a Speedgoat target computer. If you have not installed the Speedgoat library, attempting to build a real-time application with PTP causes a build error.
- Simulink Real-Time supports PTP only with Intel 82574 Ethernet cards. To verify that you have the required card, start your target computer. In the Command Window, type:

```
tg = slrt;
getPCIInfo(tg, 'Ethernet')
```

Verify that you see an entry like this entry:

```
Intel                82574L
  Bus 5, Slot 0, IRQ 10
  Ethernet controller
  VendorID 0x8086, DeviceID 0x10d3, SubVendorID 0x15bd,
    SubDeviceID 0x100a
  Released in: R2010a
  Notes: Intel 8254x Gigabit Ethernet series
```

Limitations

- The PTP network card clock acts as PTP clock. Only one clock is allowed per node.
- Run the model in **Real-Time** execution mode, not in **Freerun** mode or driven by an external interrupt. In the latter two cases, the PTP message transmission intervals can violate the PTP standard.

- You can include only one PTP configuration block in a model. You can run only one real-time application on a target computer. If you have installed multiple PTP Ethernet cards on your target computer, you can use only one of them for PTP at a time. You can use the other PTP Ethernet cards for non-PTP purposes.
- The PTP message transmission intervals (**Announce interval**, **Sync interval**, and **Min delay or pdelay request interval**) must be greater than the block sample time. Too small a message transmission interval causes a model update error.
- Simulink Real-Time can transmit PTP messages only at a multiple of the block sample time. If a transmission interval is not a multiple of the block sample time, PTP transmits the messages at the nearest multiple to the specified transmission time. As a best practice, specify all transmission intervals as integral multiples of the block sample time.
- The specification requires that a PTP node issue messages within $\pm 30\%$ of the message transmission intervals at least 90% of the time. To meet this requirement, specify message transmission intervals (**Announce interval**, **Sync interval**, and **Min delay or pdelay request interval**) at least 3 times the base sample time.
- The following factors limit accuracy:
 - Network protocol stack delay fluctuation
 - Network technology component delay fluctuations (switches, routers)
 - Clock timestamp accuracy
 - Clock oscillator stability

Choose components that minimize these factors. For example, you can use a transparent or boundary PTP clock to increase synchronization accuracy.

- A transparent PTP clock tracks the amount of time a PTP message takes to go through the device. It passes that information to nodes receiving the message.
- A boundary PTP clock has multiple PTP ports that can act as a master clock or a slave clock.
- Some systems require a PTP time source that is traceable to an International Atomic Time (TAI) clock, such as a GPS signal. To support traceability, acquire a third-party grandmaster PTP clock that provides this capability. In that case, a Simulink Real-Time target computer running PTP acts only as a slave clock.

Unsupported Features

- Simulink Real-Time supports only PTP version 2, as defined in IEEE Std 1588-2008. If a Simulink Real-Time PTP node receives a PTP version 1 message as defined in IEEE Std 1588-2002, it ignores it.
- The Simulink Real-Time implementation of PTP does not support the following functionality defined in IEEE Std 1588-2008:
 - PTP variance computation, as described in IEEE Std 1588-2008 Clause 7.6.3.
 - PTP nodes configured as one-step PTP clocks, as described in IEEE Std 1588-2008 Clause 3.1.21.

You can configure the master node as a two-step clock only, as described in IEEE Std 1588-2008 Clause 3.1.47.

- PTP management messages, as described in IEEE Std 1588-2008 Clause 15.

A Simulink Real-Time PTP node cannot transmit a PTP management message. When a Simulink Real-Time PTP node receives a PTP management message, it ignores it.

- PTP signaling messages, as described in IEEE Std 1588-2008 Clause 13.12.

A Simulink Real-Time PTP node cannot transmit a PTP signaling message. When a Simulink Real-Time PTP node receives a PTP signaling message, it ignores it.

- Optional features, as described in IEEE Std 1588-2008 Clause 16 and Clause 17.

Related Examples

- “Precision Time Protocol Troubleshooting” on page 20-24

Precision Time Protocol Blocks

IEEE 1588 Real-Time UDP

Execute IEEE 1588 Precision Time Protocol

Library

Simulink Real-Time Library for Precision Time Protocol

Description

IEEE 1588 Real-Time UDP runs the PTP protocol, using UDP to send and receive the protocol messages. The block communicates with the corresponding blocks on the other target computers, determines the time offset that synchronizes them, and adjusts the time offset.

Block Parameters

General

Device ID

From the list, select a unique number to identify the Ethernet board.

PCI bus

Enter the PCI bus number for the Ethernet card.

PCI slot

Enter the PCI slot number for the Ethernet card.

Sample time (-1 for inherited)

Enter the base sample time or a multiple of the base sample time.

Network Parameters

IP address of port

IP address of the Ethernet board, or node, carrying the PTP clock.

Subnet mask

Enter the subnet mask for the interface.

Gateway

Enter the gateway address for the interface.

Source IP address of receive packets

IP address in UDP **Receive** blocks. The default value (0.0.0.0) specifies that the node is to receive all packets sent to the ports assigned to PTP messages (ports 319 and 320).

Use a specific value for one-to-one communication. If the node is a master PTP clock node, use a specific value only if exactly one slave is connected to the master clock node.

Destination IP address of transmit packets

IP address in UDP **Transmit** blocks. Specifies the IP address of the other PTP computers or devices to which to send the PTP packets. Select one of:

- **Standard PTP Multicast (224:0:1:129, 224:0:0:107)** (default) — Default standard multicast IP address assigned to PTP. If you select this option, the PTP packets are broadcast to all computers listening on the PTP ports (ports 319 and 320). The destination IP addresses are:
 - 224.0.1.129 for non-peer-delay measurement mechanism messages (Announce, Sync, Follow_up, Delay_Req, Delay_Resp)
 - 224.0.0.107 for peer-delay measurement mechanism messages (Pdelay_Req, Pdelay_Resp, Pdelay_Resp_Follow_up)
- **Specify** — Makes the **Specify destination IP address** parameter visible.

Specify destination IP address

The default value (255.255.255.255) specifies that the node is to broadcast the packets to all listening nodes of the network. Use a specific value for one-to-one communication. If the node is a master PTP clock node, use a specific value only if exactly one slave is connected to the master clock node.

When **Destination IP address of transmit packets** is **Specify**, this parameter is visible.

Clock Parameters

Timescale (epoch)

Specify origin point of the PTP timescale. Select one of:

- **PTP (1970-01-01)** — Precision Time Protocol standard epoch, starting January 1, 1970.
- **GPS (1980-06-01)** — Global Positioning System standard epoch, starting June 1, 1980.
- **NTP (1900-01-01)** — Network Time Protocol standard epoch, starting January 1, 1900.
- **Specify** — Selecting this value makes the **Arbitrary timescale epoch (yyyy mm dd hh)** parameter visible.

Arbitrary timescale epoch (yyyy mm dd hh)

Specify origin point for PTP timescale, in year, month, day, and hour.

When **Timescale (epoch)** is **Specify**, **Arbitrary timescale epoch (yyyy mm dd hh)** is visible.

Delay measurement mechanism

Method of measuring link delays. Select one of **Request - response** and **Peer - delay**.

In a PTP network, you must configure all nodes to use the same link delay measurement mechanism.

For more information, see IEEE Std 1588-2008 Clause 7.5.4.

Slave only

When you select this check box, you cannot allocate the PTP Ethernet card that this block represents as a master PTP clock.

In **Slave only** mode, the values of the advanced parameters (**Priority 1**, **Clock class**, **Clock accuracy**, and **Priority 2**) are set to their highest values. When the parameters have these settings, the Best Master Clock Algorithm (BMCA) cannot choose the node as best master clock unless all of the other nodes have the same configuration. If the BMCA selects a **Slave only** node as best clock, the node remains in the **LISTENING** state.

Show advanced configuration parameters

When you select this check box, advanced configuration parameters are visible.

For more information, see IEEE Std 1588-2008.

Domain number

Specify the domain number of the PTP network to which the node belongs.

A Simulink Real-Time PTP node can belong to only one PTP domain at a given time. If the node receives a PTP message with a different domain number, it ignores it. For more information, see IEEE Std 1588-2008 Clause 7.1.

When you select the **Show advanced configuration parameters** check box, **Domain number** is visible.

Current UTC offset

The current UTC offset, in seconds.

If you specify a nonzero value, that value is considered valid. The `UTCOffsetValid` flag is set to `true`. Otherwise, the flag is set to `false`. For more information, see IEEE Std 1588-2008 Clause 7.2.3.

When you select the **Show advanced configuration parameters** check box, **Current UTC offset** is visible.

Priority 1

Specify an integer value in the range 0–255. When the value is 0, the node has the highest priority. When it is 255, the node has the lowest priority.

To assess the quality of two PTP clocks, the Best Master Clock Algorithm compares the following parameters, in order:

- 1 **Priority 1**
- 2 **Clock class**
- 3 **Clock accuracy**
- 4 **Priority 2**

If a parameter for one PTP clock has a smaller value than that parameter for the other clock, the algorithm selects the clock with the smaller value as the best clock. If all four parameters are equal for both clocks, the algorithm compares the MAC addresses of the nodes.

For more information, see IEEE Std 1588-2008 Clause 7.6.2.2.

When you select the **Show advanced configuration parameters** check box, **Priority 1** is visible.

Clock class

Specify a nonreserved integer value in the range 0–255. If **Clock class** is less than 128, the node cannot enter the **SLAVE** state. If **Clock class** is less than 128 and the node is not selected as the best clock, the node enters the **PASSIVE** state.

If you specify a reserved integer value, the block produces an error during model update. For more information, see IEEE Std 1588-2008 Clause 7.6.2.4. For a list of reserved and nonreserved **Clock class** values, see IEEE Std 1588-2008 Table 5.

When you select the **Show advanced configuration parameters** check box, **Clock class** is visible.

Clock accuracy

Specify a nonreserved integer value in the range 0–254.

For more information, see IEEE Std 1588-2008 Clause 7.6.2.5. For a list of reserved and nonreserved **Clock accuracy** values, see IEEE Std 1588-2008 Table 6.

When you select the **Show advanced configuration parameters** check box, **Clock accuracy** is visible.

Priority 2

Specify an integer value in the range 0–255. When the value is 0, the node has the highest priority. When it is 255, the node has the lowest priority.

For more information, see IEEE Std 1588-2008 Clause 7.6.2.3.

When you select the **Show advanced configuration parameters** check box, **Priority 2** is visible.

Time Intervals**Announce interval (second)**

The period, in seconds, of an Announce message transmitted by a node in master state.

For more information, see IEEE Std 1588-2008 Clause 9.5.8.

Sync interval (second)

The period, in seconds, of a Sync message transmitted by a node in master state.

For more information, see IEEE Std 1588-2008 Clause 9.5.9.

Min delay or pdelay request interval (second)

Period of delay request message or of peer-delay request message transmitted by a node in the slave state. When the delay measurement mechanism is **Request-response**, the block transmits delay request messages. When the mechanism is **Peer-delay**, it transmits peer-delay request messages.

For more information, see IEEE Std 1588-2008 Clauses 9.5.11 and 9.5.13.

Announce receipt timeout (in announce intervals)

Specifies the number of announce intervals a node not in the master state has to wait without receiving an announce message before the node enters the master state.

For more information, see IEEE Std 1588-2008 Clause 9.2.6.11.

External Websites

- standards.ieee.org

IEEE 1588 Ethernet

Execute IEEE 1588 Precision Time Protocol

Library

Simulink Real-Time Library for Precision Time Protocol

Description

IEEE 1588 Ethernet runs the PTP protocol, using raw Ethernet to send and receive the protocol messages. The block communicates with the corresponding blocks on the other target computers, determines the time offset that synchronizes them, and adjusts the time offset.

Block Parameters

General

Device ID

From the list, select a unique number to identify the Ethernet board.

PCI bus

Enter the PCI bus number for the Ethernet card.

PCI slot

Enter the PCI slot number for the Ethernet card.

Sample time (-1 for inherited)

Enter the base sample time or a multiple of the base sample time.

Network Parameters

Source MAC address

From the list, select:

- EEPROM

Allow the block to get the Ethernet card MAC address that is built into the Ethernet card.

Use this option if you use separate Ethernet connections to transmit data and to synchronize PTP clocks.

- **Specify** — Selecting this value makes the **Specify source MAC address** parameter visible.

Use this option if you use the same Ethernet connection to transmit data as you use to synchronize PTP clocks, and you do not know the built-in MAC address of the Ethernet card.

Specify source MAC address

Enter the MAC address for the Ethernet card. This MAC address can be the MAC address that is built into the Ethernet card, or an arbitrary MAC address that is unique within the PTP network. In particular, do not use one of the standard PTP multicast MAC addresses.

When **Source MAC address** is **Specify**, this parameter is visible.

Destination MAC address

MAC address in Ethernet transport protocol. Select one of:

- **Standard PTP Multicast (01:1B:19:00:00:00, 01:80:C2:00:00:0E)** (default) — Default multicast MAC address assigned to the PTP protocol. If you select this option, the destination MAC addresses are:
 - **01:1B:19:00:00:00** for non-peer-delay measurement mechanism messages (Announce, Sync, Follow_up, Delay_Req, Delay_Resp)
 - **01:80:C2:00:00:00:0E** for peer-delay measurement mechanism messages (Pdelay_Req, Pdelay_Resp, Pdelay_Resp_Follow_up)
- **Specify** — Selecting this value makes the **Specify destination MAC address** parameter visible.

You do not have to specify a source MAC address. The block uses the unique MAC address of the PTP Ethernet card.

Specify destination MAC address

Specify a MAC address for the message destination. MAC addresses are of the form **xx:xx:xx:xx:xx:xx**.

Use this option for **Slave only** nodes. Specify the MAC address of the master node Ethernet card. The master node uses the standard PTP multicast MAC address to transmit messages to all slave nodes.

When **Destination MAC address** is **Specify**, this parameter is visible.

Clock Parameters

Timescale (epoch)

Specify origin point of the PTP timescale. Select one of:

- **PTP (1970-01-01)** — Precision Time Protocol standard epoch, starting January 1, 1970.
- **GPS (1980-06-01)** — Global Positioning System standard epoch, starting June 1, 1980.
- **NTP (1900-01-01)** — Network Time Protocol standard epoch, starting January 1, 1900.
- **Specify** — Selecting this value makes the **Arbitrary timescale epoch (yyyy mm dd hh)** parameter visible.

Arbitrary timescale epoch (yyyy mm dd hh)

Specify origin point for PTP timescale, in year, month, day, and hour.

When **Timescale (epoch)** is **Specify**, **Arbitrary timescale epoch (yyyy mm dd hh)** is visible.

Delay measurement mechanism

Method of measuring link delays. Select one of **Request - response** and **Peer - delay**.

In a PTP network, you must configure all nodes to use the same link delay measurement mechanism.

For more information, see IEEE Std 1588-2008 Clause 7.5.4.

Slave only

When you select this check box, you cannot allocate the PTP Ethernet card that this block represents as a master PTP clock.

In **Slave only** mode, the values of the advanced parameters (**Priority 1**, **Clock class**, **Clock accuracy**, and **Priority 2**) are set to their highest values. When the

parameters have these settings, the Best Master Clock Algorithm (BMCA) cannot choose the node as best master clock unless all of the other nodes have the same configuration. If the BMCA selects a **Slave only** node as best clock, the node remains in the LISTENING state.

Show advanced configuration parameters

When you select this check box, advanced configuration parameters are visible.

For more information, see IEEE Std 1588-2008.

Domain number

Specify the domain number of the PTP network to which the node belongs.

A Simulink Real-Time PTP node can belong to only one PTP domain at a given time. If the node receives a PTP message with a different domain number, it ignores it. For more information, see IEEE Std 1588-2008 Clause 7.1.

When you select the **Show advanced configuration parameters** check box, **Domain number** is visible.

Current UTC offset

The current UTC offset, in seconds.

If you specify a nonzero value, that value is considered valid. The `UTCOffsetValid` flag is set to `true`. Otherwise, the flag is set to `false`. For more information, see IEEE Std 1588-2008 Clause 7.2.3.

When you select the **Show advanced configuration parameters** check box, **Current UTC offset** is visible.

Priority 1

Specify an integer value in the range 0–255. When the value is 0, the node has the highest priority. When it is 255, the node has the lowest priority.

To assess the quality of two PTP clocks, the Best Master Clock Algorithm compares the following parameters, in order:

- 1 Priority 1**
- 2 Clock class**
- 3 Clock accuracy**
- 4 Priority 2**

If a parameter for one PTP clock has a smaller value than that parameter for the other clock, the algorithm selects the clock with the smaller value as the best clock. If all four parameters are equal for both clocks, the algorithm compares the MAC addresses of the nodes.

For more information, see IEEE Std 1588-2008 Clause 7.6.2.2.

When you select the **Show advanced configuration parameters** check box, **Priority 1** is visible.

Clock class

Specify a nonreserved integer value in the range 0–255. If **Clock class** is less than 128, the node cannot enter the **SLAVE** state. If **Clock class** is less than 128 and the node is not selected as the best clock, the node enters the **PASSIVE** state.

If you specify a reserved integer value, the block produces an error during model update. For more information, see IEEE Std 1588-2008 Clause 7.6.2.4. For a list of reserved and nonreserved **Clock class** values, see IEEE Std 1588-2008 Table 5.

When you select the **Show advanced configuration parameters** check box, **Clock class** is visible.

Clock accuracy

Specify a nonreserved integer value in the range 0–254.

For more information, see IEEE Std 1588-2008 Clause 7.6.2.5. For a list of reserved and nonreserved **Clock accuracy** values, see IEEE Std 1588-2008 Table 6.

When you select the **Show advanced configuration parameters** check box, **Clock accuracy** is visible.

Priority 2

Specify an integer value in the range 0–255. When the value is 0, the node has the highest priority. When it is 255, the node has the lowest priority.

For more information, see IEEE Std 1588-2008 Clause 7.6.2.3.

When you select the **Show advanced configuration parameters** check box, **Priority 2** is visible.

Time Intervals

Announce interval (second)

The period, in seconds, of an Announce message transmitted by a node in master state.

For more information, see IEEE Std 1588-2008 Clause 9.5.8.

Sync interval (second)

The period, in seconds, of a Sync message transmitted by a node in master state.

For more information, see IEEE Std 1588-2008 Clause 9.5.9.

Min delay or pdelay request interval (second)

Period of delay request message or of peer-delay request message transmitted by a node in the slave state. When the delay measurement mechanism is **Request-response**, the block transmits delay request messages. When the mechanism is **Peer-delay**, it transmits peer-delay request messages.

For more information, see IEEE Std 1588-2008 Clauses 9.5.11 and 9.5.13.

Announce receipt timeout (in announce intervals)

Specifies the number of announce intervals a node not in the master state has to wait without receiving an announce message before the node enters the master state.

For more information, see IEEE Std 1588-2008 Clause 9.2.6.11.

External Websites

- standards.ieee.org

IEEE 1588 Read Parameter

Output Precision Time Protocol status parameter value

Library

Simulink Real-Time Library for Precision Time Protocol

Description

Read the parameter that you select and send its value to the block output. The block output name changes based on the parameter that you select.

Block Outputs

Name	Description
Time	<p>Current number of nanoseconds (double), counting from the beginning of the epoch.</p> <p>When you select the Time at block start check box, the value is measured at the beginning of block execution. When you clear the Time at block start check box, the value is measured at the end of block execution.</p> <p>When Parameter to read is PTP time (nanosecond), output Time is visible.</p>
Date	<p>Current time in time-of-day format. The value is a vector of size 8, data type <code>uint16</code>, containing: year, month (1–12), day of week (0–6), day of month (0–31), hour (0–23), minute (0–59), second (0–59), and millisecond (0–999).</p>

Name	Description
	When Parameter to read is PTP time (time-of-day), output Date is visible.
Offset	Last computed offset from master PTP clock node, in nanoseconds (double). When Parameter to read is Offset from Master, output Offset is visible.
PDelay	Last computed mean path delay, in ns (double). When Parameter to read is Path delay, output PDelay is visible.

Name	Description
State	<p>Current state of the protocol state machine. Returns one of:</p> <ul style="list-style-type: none"> • 1 = INITIALIZING — Initializing data set and communication protocol • 2 = FAULTY — Occurrence of serious fault • 3 = DISABLED — Management message disables the node • 4 = LISTENING — Waiting for announce receipt timeout period to expire • 5 = PRE_MASTER — Intermediate state before moving to MASTER state after execution of Best Master Clock Algorithm (BMCA) • 6 = MASTER — Node is the master PTP clock node • 7 = PASSIVE — BCMA designates node as passive • 8 = UNCALIBRATED — Intermediate state before moving to SLAVE state after execution of BMCA • 9 = SLAVE — Node is a slave node <p>For more information, see IEEE Std 1588-2008 Clause 9.2.5.</p> <p>When Parameter to read is Protocol state, output State is visible.</p>

Block Parameters

Parameter to read

Specify parameter to read and make corresponding output port visible. Select one of:

PTP time (nanosecond) — Reveals port Time and parameter **Time at block start**

PTP time (time-of-day) — Reveals port Date

Offset from Master — Reveals port Offset

Path delay — Reveals port PDelay

Protocol state — Reveals port State

Time at block start

When you select this check box, the Time output contains the time at the beginning of block execution. When you clear this check box (the default), the Time output contains the time at the end of block execution.

Setting **Parameter to read** to PTP time (nanosecond) makes this check box visible.

Sample time (-1 for inherited)

Enter the base sample time or a multiple of the base sample time.

External Websites

- standards.ieee.org

IEEE 1588 Sync Execution

Synchronize model execution to Precision Time Protocol clock

Library

Simulink Real-Time Library for Precision Time Protocol

Description

When the PTP time is a multiple of the fundamental step size of the model, this block causes a real-time interrupt.

Make measurements across multiple target computers at the same time step by using the **IEEE 1588 Sync Execution** block. The block uses a control loop to adjust the step size toward the synchronization objective. During this process, the control loop decreases or increases the step size. When the control loop decreases the step size, the CPU can become overloaded. You can decrease the maximum adjustment value by decreasing the **Proportional gain** parameter. The upper bound of the adjustment value is 10% of the model fundamental sample time, regardless of the **Proportional gain** value.

Use this block in every model that requires synchronized execution, whether it is a PTP master or slave model. To use this block, in the Simulink Real-Time options, set the real-time interrupt source to **Timer**. As a best practice, for all models, use the same fundamental sample time. Set the sample time in this block to that fundamental sample time.

Block Outputs

Name	Description
Time	PTP time value at which the interrupt occurs, in seconds.
Delta	Current difference, in seconds, between the PTP time at the interrupt and the nearest PTP time that is a multiple of the fundamental sample time.

Block Parameters

Proportional gain

Enter the proportional gain of the kernel clock adjustment controller. The current value of output port Delta is multiplied by the proportional gain to get the first part of the controller output.

Low pass filter pole

Enter the pole of the low-pass filter of the kernel clock adjustment controller. The low-pass filter is a discrete-time, first-order transfer function. The low-pass filter tracks the rate difference between the kernel and PTP clocks and provides the second part of the controller output.

PTP clock synchronization threshold (seconds)

Enter the PTP clock synchronization threshold value, in seconds, at which the controller begins to adjust the kernel clock. The effect of this value depends on the PTP node state:

- Slave node — The controller starts the kernel adjustment only when the slave PTP clock offset from the master clock is less than or equal to this threshold value.
- Master node — The controller starts the kernel clock adjustment immediately after it enters the master state, regardless of the value of this parameter.

As a best practice, to start the kernel clock adjustment only when the PTP clock itself is stable, keep this value less than or equal to a millisecond.

Sample time (-1 for inherited)

Enter the base sample time or a multiple of the base sample time.

See Also

Transfer Fcn First Order

Related Examples

- “IEEE® 1588™ Precision Time Protocol - Execution Synchronization”

External Websites

- standards.ieee.org

IEEE 1588 Sync Status

Output synchronization status of Precision Time Protocol

Library

Simulink Real-Time Library for Precision Time Protocol

Description

When the absolute value of the offset from the master PTP clock is less than or equal to the specified threshold, the output port value is `true`. If the node is selected as the master clock, the output port value becomes true when it enters the MASTER state.

Block Outputs

Name	Description
S	When the absolute value of the offset from the master PTP clock is less than or equal to the specified threshold, returns <code>true</code> .

Block Parameters

Offset threshold (second)

Threshold value, in seconds, from which the node is considered well synchronized to the master PTP clock node. The default value is 10 μ s. The minimum allowed value is 1 μ s.

Sample time (-1 for inherited)

Enter the base sample time or a multiple of the base sample time.

External Websites

- standards.ieee.org

IEEE 1588 Setup

Configure node for Precision Time Protocol execution

Library

Simulink Real-Time Library for Precision Time Protocol

Description

Sets up the Precision Time Protocol for the specified transport protocol (Ethernet or UDP). Exposes as outputs the state of the protocol, the delay measurement mechanism, and triggers for sending messages.

The PTP internal block descriptions are for informational purposes only. You cannot use these blocks by themselves in a model. The subsystem mask controls the block parameters. Do not edit the parameters directly.

Block Outputs

Name	Description
State	<p>Current state of the protocol state machine. Returns one of:</p> <ul style="list-style-type: none"> • 1 = INITIALIZING — Initializing data set and communication protocol • 2 = FAULTY — Occurrence of serious fault • 3 = DISABLED — Management message disables the node • 4 = LISTENING — Waiting for announce receipt timeout period to expire • 5 = PRE_MASTER — Intermediate state before moving to MASTER state

Name	Description
	after execution of Best Master Clock Algorithm (BMCA) <ul style="list-style-type: none"> • 6 = MASTER — Node is the master PTP clock node • 7 = PASSIVE — BCMA designates node as passive • 8 = UNCALIBRATED — Intermediate state before moving to SLAVE state after execution of BMCA • 9 = SLAVE — Node is a slave node For more information, see IEEE Std 1588-2008 Clause 9.2.5.
DM	Value of Delay measurement mechanism . Returns one of: <ul style="list-style-type: none"> • 1 = Request - response • 2 = Peer - delay
ST	Value of synchronization trigger, true every Sync interval
AT	Value of announce trigger, true every Announce interval
DT	Value of delay request trigger, true every Min delay or pdelay request interval

Block Parameters

General

Device ID

From the list, select a unique number to identify the Ethernet board. Select the same **Device ID** as the one that you selected for the protocol configuration block.

Transport protocol

The network protocol for communicating messages. Select one of **Real-Time UDP** and **Raw Ethernet**.

IP address

IP address of Ethernet card, or node, represented by the **PTP Setup** block.

Board time increment value

Value that changes the PTP clock.

PCI bus

Enter the PCI bus number for the Ethernet card.

PCI slot

Enter the PCI slot number for the Ethernet card.

Time Properties

Time source

Source of PTP clock signal. Select one of:

- **Precise System Time** — Synchronization of system time without hardware timestamp
- **Tick Counter** — Synchronization of tick counter read without hardware timestamp
- **Ethernet board** — Clock on PTP Ethernet board

Timescale (epoch)

Specify origin point of the PTP timescale. Select one of:

- **PTP (1970-01-01)** — Precision Time Protocol standard epoch, starting January 1, 1970.
- **GPS (1980-06-01)** — Global Positioning System standard epoch, starting June 1, 1980.
- **NTP (1900-01-01)** — Network Time Protocol standard epoch, starting January 1, 1900.
- **Specify** — Selecting this value makes the **Arbitrary timescale epoch (yyyy mm dd hh)** parameter visible.

Arbitrary timescale epoch (yyyy mm dd hh)

Specify origin point for PTP timescale, in year, month, day, and hour.

When **Timescale (epoch)** is **Specify**, **Arbitrary timescale epoch (yyyy mm dd hh)** is visible.

Delay measurement mechanism

Method of measuring link delays. Select one of **Request - response** and **Peer - delay**.

In a PTP network, you must configure all nodes to use the same link delay measurement mechanism.

For more information, see IEEE Std 1588-2008 Clause 7.5.4.

Sample time (-1 for inherited)

Enter the base sample time or a multiple of the base sample time.

Slave only

When you select this check box, you cannot allocate the PTP Ethernet card that this block represents as a master PTP clock.

In **Slave only** mode, the values of the advanced parameters (**Priority 1**, **Clock class**, **Clock accuracy**, and **Priority 2**) are set to their highest values. When the parameters have these settings, the Best Master Clock Algorithm (BMCA) cannot choose the node as best master clock unless all of the other nodes have the same configuration. If the BMCA selects a **Slave only** node as best clock, the node remains in the LISTENING state.

Time Intervals**Announce interval (second)**

The period, in seconds, of an Announce message transmitted by a node in master state.

For more information, see IEEE Std 1588-2008 Clause 9.5.8.

Sync interval (second)

The period, in seconds, of a Sync message transmitted by a node in master state.

For more information, see IEEE Std 1588-2008 Clause 9.5.9.

Min delay or pdelay request interval (second)

Period of delay request message or of peer-delay request message transmitted by a node in the slave state. When the delay measurement mechanism is **Request -**

response, the block transmits delay request messages. When the mechanism is Peer-delay, it transmits peer-delay request messages.

For more information, see IEEE Std 1588-2008 Clauses 9.5.11 and 9.5.13.

Announce receipt timeout (in announce intervals)

Specifies the number of announce intervals a node not in the master state has to wait without receiving an announce message before the node enters the master state.

For more information, see IEEE Std 1588-2008 Clause 9.2.6.11.

Advanced

Domain number

Specify the domain number of the PTP network to which the node belongs.

A Simulink Real-Time PTP node can belong to only one PTP domain at a given time. If the node receives a PTP message with a different domain number, it ignores it. For more information, see IEEE Std 1588-2008 Clause 7.1.

When you select the **Show advanced configuration parameters** check box, **Domain number** is visible.

Current UTC offset

The current UTC offset, in seconds.

If you specify a nonzero value, that value is considered valid. The `UTCOffsetValid` flag is set to `true`. Otherwise, the flag is set to `false`. For more information, see IEEE Std 1588-2008 Clause 7.2.3.

When you select the **Show advanced configuration parameters** check box, **Current UTC offset** is visible.

Priority 1

Specify an integer value in the range 0–255. When the value is 0, the node has the highest priority. When it is 255, the node has the lowest priority.

To assess the quality of two PTP clocks, the Best Master Clock Algorithm compares the following parameters, in order:

- 1 Priority 1**
- 2 Clock class**

3 Clock accuracy

4 Priority 2

If a parameter for one PTP clock has a smaller value than that parameter for the other clock, the algorithm selects the clock with the smaller value as the best clock. If all four parameters are equal for both clocks, the algorithm compares the MAC addresses of the nodes.

For more information, see IEEE Std 1588-2008 Clause 7.6.2.2.

When you select the **Show advanced configuration parameters** check box, **Priority 1** is visible.

Clock class

Specify a nonreserved integer value in the range 0–255. If **Clock class** is less than 128, the node cannot enter the SLAVE state. If **Clock class** is less than 128 and the node is not selected as the best clock, the node enters the PASSIVE state.

If you specify a reserved integer value, the block produces an error during model update. For more information, see IEEE Std 1588-2008 Clause 7.6.2.4. For a list of reserved and nonreserved **Clock class** values, see IEEE Std 1588-2008 Table 5.

When you select the **Show advanced configuration parameters** check box, **Clock class** is visible.

Clock accuracy

Specify a nonreserved integer value in the range 0–254.

For more information, see IEEE Std 1588-2008 Clause 7.6.2.5. For a list of reserved and nonreserved **Clock accuracy** values, see IEEE Std 1588-2008 Table 6.

When you select the **Show advanced configuration parameters** check box, **Clock accuracy** is visible.

Priority 2

Specify an integer value in the range 0–255. When the value is 0, the node has the highest priority. When it is 255, the node has the lowest priority.

For more information, see IEEE Std 1588-2008 Clause 7.6.2.3.

When you select the **Show advanced configuration parameters** check box, **Priority 2** is visible.

External Websites

- standards.ieee.org

IEEE 1588 Adjust Time

Run Precision Time Protocol clock correction servo

Library

Simulink Real-Time Library for Precision Time Protocol

Description

When `Trigger` is true, IEEE 1588 Adjust Time performs time offset correction at every sample time until the offset drops below a threshold value. It then switches to rate correction. During rate correction, the block adjusts the time increment value of the Ethernet card to track the master PTP clock rate.

The PTP internal block descriptions are for informational purposes only. You cannot use these blocks by themselves in a model. The subsystem mask controls the block parameters. Do not edit the parameters directly.

Block Inputs

Name	Description
Trigger	While <code>Trigger</code> is true, the block runs the time adjustment algorithm at every time step.

Block Parameters

Sample time (-1 for inherited)

Enter the base sample time or a multiple of the base sample time.

External Websites

- standards.ieee.org

IEEE 1588 Create Message

Pack a Precision Time Protocol message for transmission

Library

Simulink Real-Time Library for Precision Time Protocol

Description

Creates and packs an IEEE 1588 message of a type specified by parameter **Message type**. Sends the message and the message length to the **Data** and **Length** outputs, respectively.

By default, **IEEE 1588 Create Message** creates a message at every sample time. If you select the **Enable trigger port** check box, **IEEE 1588 Create Message** creates a message at every sample time only when the trigger is **true**.

The PTP internal block descriptions are for informational purposes only. You cannot use these blocks by themselves in a model. The subsystem mask controls the block parameters. Do not edit the parameters directly.

Block Inputs and Outputs

Inputs

Name	Description
Trigger	While Trigger is true , the block creates a message at every sample time. When Enable trigger port is true, this input is visible.

Outputs

Name	Description
Data	Message data in a <code>uint8</code> array.

Name	Description
Length	Message data length (double).

Block Parameters

Message type

Select the PTP message type to pack. Select one of Sync, Delay_Req, Pdelay_Req, Pdelay_Resp, Follow_up, Delay_Resp, Pdelay_Resp_Follow_up, and Announce.

For more information, see IEEE Std 1588-2008 Clause 7.3.3.

Sample time (-1 for inherited)

Enter the base sample time or a multiple of the base sample time.

Enable trigger port

Selecting this check box makes input port Trigger visible.

External Websites

- standards.ieee.org

IEEE 1588 Process Message

Process a received Precision Time Protocol message

Library

Simulink Real-Time Library for Precision Time Protocol

Description

Unpack a received PTP message and execute the actions that the message data requires. For example, get timestamps and calculate offset.

The PTP internal block descriptions are for informational purposes only. You cannot use these blocks by themselves in a model. The subsystem mask controls the block parameters. Do not edit the parameters directly.

Block Inputs and Outputs

Inputs

Name	Description
Data	Message data in a <code>uint8</code> array.
Length	Message data length (<code>double</code>).

Outputs

Name	Description
Flag	If <code>true</code> , the two-steps flag bit in the message is set, otherwise, the bit is cleared.
Type	Message type (<code>uint8</code>). Return one of: <ul style="list-style-type: none"> • 0 = Sync • 1 = Delay_Req • 2 = Pdelay_Req

Name	Description
	<ul style="list-style-type: none">• 3 = Pdelay_Resp• 8 = Follow_up• 9 = Delay_Resp• 10 = Pdelay_Resp_Follow_up• 11 = Announce <p>For more information, see IEEE Std 1588-2008 Clause 7.3.3.</p>

Block Parameters

Sample time (-1 for inherited)

Enter the base sample time or a multiple of the base sample time.

External Websites

- standards.ieee.org

IEEE 1588 Sync Error

Output block execution step size and offset delta of real-time interrupt

Library

Simulink Real-Time Library for Precision Time Protocol

Description

The block returns the block execution step size as measured by the PTP clock. It also returns the following information:

- The PTP time when the real-time interrupt triggers.
- The difference between the PTP time at the real-time interrupt and the nearest PTP time that is a multiple of the fundamental sample time.

To use this block, in the Simulink Real-Time options, set the real-time interrupt source to Timer.

The PTP internal block descriptions are for informational purposes only. You cannot use these blocks by themselves in a model. The subsystem mask controls the block parameters. Do not edit the parameters directly.

Block Outputs

Name	Description
Time	PTP time value when the real-time interrupt occurs, in seconds
Step	Actual block execution step size, in seconds, as calculated from PTP clock measurements
Delta	Current difference, in seconds, between the PTP time at the interrupt and the nearest PTP time that is a multiple of the fundamental sample time

Block Parameters

Sample time (-1 for inherited)

Enter the base sample time or a multiple of the base sample time.

External Websites

- standards.ieee.org

Adjust Step Size

Adjust block step size during execution

Library

Simulink Real-Time Library for Precision Time Protocol

Description

The block sets the execution step size of the block. The block execution step size is equal to the fundamental sample time plus the value of **Adj**, scaled to the block sample time. For example, if the block sample time is twice the fundamental sample time, each fundamental execution step gets half of the **Adj** value.

When the block changes the execution step size, the new value remains active until the block changes the value again.

The PTP internal block descriptions are for informational purposes only. You cannot use these blocks by themselves in a model. The subsystem mask controls the block parameters. Do not edit the parameters directly.

Block Inputs

Name	Description
Adj	Step size increment

Block Parameters

Sample time (-1 for inherited)

Enter the base sample time or a multiple of the base sample time.

External Websites

- standards.ieee.org

Current Step Size

Output current block execution step size

Library

Simulink Real-Time Library for Precision Time Protocol

Description

The block returns the current block execution step size. When you select **Enable base rate output port**, output port BR shows the base rate or model fundamental step size.

The PTP internal block descriptions are for informational purposes only. You cannot use these blocks by themselves in a model. The subsystem mask controls the block parameters. Do not edit the parameters directly.

Block Outputs

Name	Description
CS	Current block execution step size, in seconds
BR	Base rate, or model fundamental step size, in seconds When you select Enable base rate output port , this port becomes visible.

Block Parameters

Sample time (-1 for inherited)

Enter the base sample time or a multiple of the base sample time.

Enable base rate output port

To make the BR output visible, select this check box.

External Websites

- standards.ieee.org

SAE J1939

SAE J1939 Blocks

The Simulink Real-Time J1939 blocks enable you to send and receive messages over a FIFO-mode CAN network using the SAE J1939 message protocol. See “CAN”.

Before you start, provide a J1939 database in `.dbc` format.

The “J1939 I/O - Using Transport Protocol” example illustrates the transmission and reception of J1939 data over a FIFO mode CAN network. It uses a loopback connection of two CAN ports in a single target computer. The example requires a J1939 database file, `C:\work\J1939_demo.dbc`, which the Simulink Real-Time software does not supply. You must provide your own database file, which must contain the requested information outlined in the example.

This example assumes familiarity with the SAE J1939 specifications.

Related Examples

- “J1939 I/O - Using Transport Protocol”

More About

- “CAN”

SAE J1939 Blocks

J1939 Controller Application

J1939 Controller Application

Library

Simulink Real-Time Library for J1939

Description

The **J1939 Controller Application** block supports address claiming. It enables the dynamic exchange of address information with other nodes in the J1939 bus, resolving conflicts. Once conflicts are resolved, the blocks on the CAN network each have unique addresses and IDs.

Use this block to register your J1939 device on the CAN bus. Associate this block with the **J1939 Transmit Message** and **J1939 Receive Message** blocks.

The block has two tab groups, **General** and **NAME**. The **General** tab contains general block information. The **NAME** tab has ten parameters that, when combined, create a unique identification address (NAME) for this J1939 device. Refer to the SAE J1939-81 and base SAE J1939 specifications for details.

Block Outputs

This block has the following output port:

Status output (Optional)

Outputs a status signal.

Current node address output (Optional)

Outputs current node address.

Block Parameters

General tab:

CA ID

Enter the controller application ID.

Protocol Stack ID

Enter the protocol stack ID.

Node address

From a range of 0 to 253, specify the node address of the node for which J1939 communication is to occur. This value is the source address for the J1939 communication. Set this address to the same as that in the **J1939 Transmit Message** block.

Show status output

Select this check box to enable an output status signal.

Show current node address as output

Select this check box to enable an output current node address signal.

NAME tab:**Identity Number**

Enter the identity number for the controller application. Use the identify number provided by the ECU manufacturer.

Manufacturer Code

Enter the code of the electronic control unit (ECU) manufacturer.

ECU Instance

Enter a number to identify the particular ECU associated with **Function**.

If this number identifies the first or only instance, enter 0.

Function Instance

Enter a number to identify an instance of the function for the **Vehicle System** in the CAN network.

Function

Enter an 8-bit value for the function for this controller application. See Appendix B of the base SAE J1939 specification for a list of allowed function values.

If you enter a value between 0 and 127, the block independently evaluates the function value.

If you enter a value greater than 127, the block takes into account the value of the **Vehicle System** parameter when evaluating the function value.

Reserved

Reserved. Leave set to 0.

Vehicle System

Enter a 7-bit value for the vehicle system for this controller application. See Appendix B of the base SAE J1939 specification for a list of allowed vehicle system values.

Vehicle System Instance

Enter a number to identify an instance of the vehicle system in the CAN network.

If this number identifies the first or only instance, enter 0.

Industry Group

Enter a 3-bit value for the industry group for this controller application. See Appendix B of the base SAE J1939 specification for a list of allowed industry group values.

Arbitrary Address Capable

Select this check box to allow the controller application to resolve address claim conflicts with arbitrary source addresses.

External Websites

- www.sae.org/

J1939 Database (CANdb) Setup

J1939 Database Setup

Library

Simulink Real-Time Library for J1939

Description

The J1939 Database Setup block is where you specify the user-supplied database for the J1939 block set. Use one block per model.

Block Parameters

J1939 database file

Specify the J1939 database location and file name. For example, enter `J1939.dbc` if the file is in the current folder; otherwise enter the full path with the file name, such as `C:\work\J1939.dbc`.

This file defines the J1939 message set and is in a format defined by Vector Informatik GmbH.

Note: You must supply the database file. The Simulink Real-Time software does not supply this file.

J1939 Database Format

From the list, select:

- **J1939 PG — Full Extended CAN ID**

Specifies that the database format is the new version of CANdb. The block extracts the Parameter Group Number (PGN) from the full extended CAN ID (29-bit).

- **J1939 PG**

Specifies that the database format is simplified ID (CANDB++ 2.7 SP7 and before).

External Websites

- www.sae.org/

J1939 Message Trigger

J1939 Message Triggering

Library

Simulink Real-Time Library for J1939

Description

The J1939 Message Trigger block triggers the transmission of a J1939 message under conditions that the block specifies. When using this block in your model, connect its Trigger Out port to the Trigger input port of the J1939 Transmit Message block. The possible triggering conditions are:

- Nonzero input at the Trigger Message input port
- Expiration of the repetition interval
- A detected change in the input signal

Block Inputs

This block has the following input ports:

Trigger Message

Manually triggers the message transmission when the input value is 1.

Signal For Change Detection

Detects changes in the input.

Block Outputs

This block has the following output ports:

Trigger Out

Outputs an active signal when a condition for triggering a message occurs. Connect this output to the Trigger input port of the J1939 Transmit Message block.

Block Parameters

Repeat on interval

Select this check box to enable periodic triggering at the interval specified in the **Repetition Interval** parameter.

Repetition Interval (ms)

Specify the enabled repetition interval in milliseconds. The repetition interval must be an integer multiple of the model update rate.

Send on a change in signal

Select this check box to enable triggering when both of the following are true:

- Input signal wired to the Signal For Change Detection port input port changes by at least the value in the **Minimum Change Threshold** parameter.
- Specified time in the **Minimum Change Interval** parameter has expired.

Minimum Change Threshold (%)

Specify the threshold change to trigger a message. The trigger event is a change in the input signal relative to the signal value from the previous triggering.

Minimum Change Interval (ms)

Specify the minimum time for the block to wait after a message transmission occurs because of a change in the signal.

External Websites

- www.sae.org/

J1939 Protocol Stack

J1939 Protocol Stack instance

Library

Simulink Real-Time Library for J1939

Description

The J1939 Protocol Stack block defines a J1939 protocol stack instance that you can associate with the CAN boards. This block is useful for the transmission and reception of CAN data to or from the bus. For each selected CAN board, you must have a corresponding CAN FIFO Setup block in the model. The protocol stack handles both the regular J1939 communication and the (optional) Transport Protocol functionality. Use this block with the J1939 Transmit Message and/or J1939 Receive Message blocks.

Block Parameters

General tab:

Protocol Stack ID

Enter the protocol stack ID.

Max CAN Message Receive (Per Sample Time)

Specify maximum number of CAN messages that the block can receive (process) in a single sample time.

Max CAN Message Transmit (Per Sample Time)

Specify maximum number of CAN messages the block can send in a single sample time.

Sample time

Specify the sample rate for the protocol stack.

Transport Protocol tab:

Enable Transport Protocol

Select this check box to enable the transport protocol. Enabling the transport protocol allows for the sending and receiving of J1939 data, whose size is greater than 8 bytes, over the CAN bus.

Maximum Concurrent Sessions

Specify maximum transport protocol sessions that can be active at a given time.

Network Management tab**Enable Address Claiming**

Select this check box to enable address claiming. Selecting this check box enables J1939 Controller Application blocks to negotiate node addresses with other nodes on the bus.

External Websites

- www.sae.org/

J1939 Receive Message

J1939 Receive Message

Library

Simulink Real-Time Library for J1939

Description

The J1939 Receive Message block receives a J1939 message. The J1939 database file defines the message type. You specify the J1939 database with the J1939 Database (CANdb) Setup block.

Block Outputs

Signal Output(s)

Depending on the J1939 message defined in the J1939 database file, the block can have multiple output signal ports. If the bit length of a signal exceeds 32, the output is a byte array; otherwise, the block output data type is double.

New Message Received (Optional)

Outputs 1 when a new message is received from the CAN bus; otherwise, outputs 0.

Block Parameters

PGN

From the list, select the parameter group number. The contents of this list vary depending on the messages that the J1939 database file specifies.

CA ID

Specify the ID of the controller application that this block maps to. The ID must match the CA ID value of the corresponding J1939 Controller Application block.

Source Address Filter (255:all)

Specify the source node address from which the block is to expect messages. Type 255 to receive messages from any node.

Destination Address Filter

From the list, select the node destination of the expected message:

- global and specific

Receive all messages for all types of destination nodes.

- global only

Receive only broadcast messages.

- CA specific only

Receive only messages sent to this node.

Show 'New Message Received' output port

Select this check box to create a New Message Received output port.

External Websites

- www.sae.org/

J1939 Transmit Message

J1939 Transmit

Library

Simulink Real-Time Library for J1939

Description

The J1939 Transmit Message block transmits a J1939 message. The J1939 database file defines the message type. You specify the J1939 database with the J1939 Database (CANdb) Setup block.

Block Inputs

- Trigger

Enables the transmission of the message for that sample (a value of 1 indicates send, a value of 0 indicates do not send).

- Signal Input(s)

Depending on the J1939 message defined in the J1939 database file, the block can have multiple input signal ports. If the bit length of a signal exceeds 32, the input is a byte array; otherwise, the block input data type is double.

Block Parameters

PGN

From the list, select the parameter group number. The contents of this list vary depending on the messages that the J1939 database file specifies.

CA ID

Identifies the controller application that this block maps to. The ID must match the **CA ID** value of the corresponding J1939 Controller Application block.

Priority (0-7; highest to lowest)

From a range of 0 to 7, specify the priority for the message transmission. 0 is the highest, 7 is the lowest.

Destination Address (0-253 or 255)

Specify the node address of the destination node. Type 255 for broadcast.

Note: For message-oriented PGNs, this block ignores this parameter.

External Websites

- www.sae.org/

Shared Memory Support

This topic describes implementations of reflective (shared) memory by various manufacturers.

- “Create GE Fanuc Shared Partitions” on page 24-2
- “Initialize GE Fanuc Shared Nodes” on page 24-4
- “GE Fanuc Shared Partition Structure” on page 24-6
- “GE Fanuc Shared Node Initialization Structure” on page 24-8
- “GE Intelligent Platforms Shared Memory” on page 24-13
- “Create GE Intelligent Platforms Shared Partitions” on page 24-14
- “Initialize GE Intelligent Platforms Shared Nodes” on page 24-17
- “GE Intelligent Platforms Shared Partition Structure” on page 24-19
- “GE Intelligent Platforms Shared Node Initialization Structure” on page 24-21
- “Create Curtiss-Wright Shared Partitions” on page 24-24
- “Initialize Curtiss-Wright Shared Nodes” on page 24-26
- “Curtiss-Wright Shared Partition Structure” on page 24-27
- “Curtiss-Wright Shared Node Initialization Structure” on page 24-32

Create GE Fanuc Shared Partitions

The Simulink Real-Time software uses a model for reflective memory (also known as shared memory) that includes Simulink blocks for shared memory driver functions and MATLAB structures to define node initialization and shared memory partitions. This topic describes the Simulink Real-Time support of the GE[®] Fanuc Embedded Systems VMIPCI-5565 (formerly from VMIC) and PCI-5565PIORC boards. Both the VMIPCI-5565 and PCI-5565PIORC boards are fully supported and will be collectively referenced as PCI-5565 in the documentation. Simulink Real-Time supports these boards with the same set of blocks.

To use the PCI-5565 shared memory blocks, you must define shared memory partition structures. A partition structure describes how you want to allocate (partition) the shared memory. The Simulink Real-Time software allocates shared memory as segments of data that are packed into memory regions or partitions. Along with the Shared Memory Pack and Shared Memory Unpack blocks, the following PCI-5565 blocks use shared memory partition structures:

- GE Fanuc 5565 read
- GE Fanuc 5565 write

After defining the shared memory partitions, you can add PCI-5565 shared memory driver blocks to your Simulink model. See “GE Fanuc Shared Partition Structure” on page 24-6 for the complete list of fields in a partition.

The following description refers to the `completepartitionstruct` command. Type

```
help completepartitionstruct
```

for more information.

- Create a partition structure in one of the following ways. Using the `completepartitionstruct` command at the MATLAB Command Window, create a default partition structure. For example, type

```
Partition = completepartitionstruct([], '5565')
```

```
Partition =
```

```
Address: '0x0'  
Type: 'uint32'  
Size: '1'
```

```
Alignment: '4'  
Internal: [1x1 struct]
```

- At the MATLAB Command Window, create a user-defined partition structure. The easiest way to do this is to create a script file, partially define a structure, load that script into the MATLAB workspace, and supplement the resulting structure with a call to the `completepartitionstruct` function. For example

```
Partition(1).Address='0x5000';  
Partition(1).Type='int8';  
Partition(1).Size='10';  
Partition(2).Type='uint16';  
Partition(2).Size='5';  
Partition(3).Type='uint8';  
Partition(3).Size='1';  
Partition(3).Alignment='8';  
Partition(4).Type='double';  
Partition(4).Size='3';
```

This example defines a partition with four segments.

- The **Address** field is optional. Only specify this field for the first segment of a partition. The elements of a partition are defined as a continuous memory block from the first address. The function extrapolates segment addresses from the first segment definition. If you have or require fragmented memory, use multiple partitions.
- The **Type** and **Size** fields are required for all segments in the partition structure.
- The **Alignment** value is optional. It is '4' by default, which forces segments that do not have alignment specifications to start on 4 byte (32 bit) boundaries. In the preceding partition definition, the third segment (`Partition(3)`) has an alignment of '8'.
- The base addresses of subsequent segments are defined by the data type, size, and alignment of the preceding segment.
- Call the `completepartitionstruct()` command to fully populate the partition structure.

```
Partition = completepartitionstruct(Partition,'5565');
```

Initialize GE Fanuc Shared Nodes

In addition to shared memory partitions, you must also define a node initialization structure before using the PCI-5565 shared memory blocks. A node initialization structure describes the shared memory partitions (see “Create GE Fanuc Shared Partitions” on page 24-2) and the PCI-5565 board configuration, including interrupt settings, if used. The following PCI-5565 block requires a shared memory node initialization structure.

- GE Fanuc 5565 init
- GE Fanuc 5565 read

After defining the node initialization structure, you can add PCI-5565 shared memory driver blocks to your Simulink model. See “GE Fanuc Shared Node Initialization Structure” on page 24-8 for the complete list of fields in a node initialization structure.

The following description refers to the `completenodestruct` command. Type

```
help completenodestruct
```

for more information.

- Create a node initialization structure in one of the following ways. Using the `completenodestruct` command at the MATLAB Command Window, create a default node initialization structure. For example, type

```
node=completenodestruct([], '5565')
```

```
node =
```

```
    Interface: [1x1 struct]  
    Partitions: [1x1 struct]
```

- Now modify the structure fields to meet your requirements. For example:

```
node.Interface.NodeID = '128';  
node.Partitions = Partition;
```

- A user-defined node structure, created with MATLAB code or from the MATLAB Command Window and supplement the resulting structure with a call to the `completenodestruct` function. For example:

```
node.Interface.NodeID = '128';
```



```
node.Partitions = Partition;  
node.completenodestruct(node, '5565');
```

GE Fanuc Shared Partition Structure

You do not need to use all the fields of a partition initialization structure. However, knowing the possible structure fields will be helpful when you are setting up to use shared memory.

A shared memory partition structure has the following fields:

```

    Address: '0x0'
           Type: 'uint32'
           Size: '1'
Alignment: '4'
Internal: [1x1 struct]

```

where

Partition Fields	Description
Address	<p>Specifies the base address (in hexadecimal) of the memory partition within the node's shared memory space. The default value is '0x0', the first location in shared memory.</p> <p>Align partition addresses on 32-bit word boundaries (for example, 0x0, 0x4, 0x8, and so forth).</p>
Type	<p>Specifies the data type of the memory segment. Specify one of the following types:</p> <ul style="list-style-type: none"> • <code>single</code> (IEEE Single Precision) • <code>double</code> (IEEE Double Precision) • <code>uint8</code> • <code>int8</code> • <code>uint16</code> • <code>int16</code> • <code>uint32</code> • <code>int32</code> • <code>Boolean</code> (a single byte represents a boolean value) <p>The default value is '<code>uint32</code>'. The minimum partition size is 32 bits.</p>

Partition Fields	Description
Size	<p>Specifies the dimension and size of the memory segment. You can enter a scalar value or a value with the $[m,n]$ format. The default value is '1'.</p> <ul style="list-style-type: none">• scalar — Treats the Size entry as the specification of the length of a non-oriented array or vector• $[m,n]$ — Treats the Size entry as an array dimension. The total number of elements in this segment is $m*n$.
Alignment	<p>If another partition precedes this partition, defines the byte alignment of this segment. Specify one of the following alignment values: 1, 2, 3, 4, or 8. The default value is '4'. This value forces a double word boundary alignment.</p>
Internal	<p>Reserved for internal use.</p>

GE Fanuc Shared Node Initialization Structure

A node initialization structure has the following fields:

```
Interface: [1x1 struct]
Partitions: [1x1 struct]
```

where

Node Structure Fields	Description
Interface	<p>Specifies how the board is configured. The Interface structure has the following fields, three of which are structures:</p> <ul style="list-style-type: none"> • Mode — Configures board registers (see “Board Mode” on page 24-8) • Interrupts — Enables the board to generate PCI interrupts from network events that have been broadcast from other nodes, or in response to error conditions (see “Board Interrupts” on page 24-9) • NodeID — Specifies the node ID for the board (see “Board Node ID” on page 24-11) • Internal — Reserved for internal use
Partitions	Stores the shared memory segments (see “Create GE Fanuc Shared Partitions” on page 24-2)

Board Mode

The PCI-5565 board has a number of registers that you can set through the `Interface.Mode` field. To display the board mode fields, type

```
>> node.Interface.Mode

ans =
    StatusLEDOff: 'off'
    TransmitterDisable: 'off'
    DarkOnDarkEnable: 'off'
    LoopbackEnable: 'off'
    LocalParityEnable: 'off'
    MemoryOffset: '0'
    MemorySize: '64MByte'
```

Note that mode values interact with the PCI-5565 board setting of the LSR1 (Local Control and Status Register 1) and LIER (Local Interrupt Enable Register) registers. Refer to the PCI-5565 product documentation for further details on these two registers. To monitor the status of these modes, select the **Error Status Port** check box of the GE Fanuc 5565 read or GE Fanuc 5565 write block.

Of particular note are the following modes:

Board Modes	Description
StatusLEDOff	Turns the PCI-5565 board status LED on and off. Setting this value to 'off' turns off the LED when the Simulink Real-Time model runs, setting this value to 'on' turns on the LED when the Simulink Real-Time model runs. When the Simulink Real-Time software terminates, the LED status reverses in both cases. The default value is 'off'.
MemoryOffset	Applies a global offset to the network data transfers coming from the PCI-5565 board. The following table lists offset values and the resulting offset. The default value is '0'.
MemorySize	Specifies the minimum memory size required, in the format 'sizeMByte'. The PCI-5565 driver checks this value against the memory size of the PCI-5565 board. If you enter a size in this field that is larger than the actual PCI-5565 board memory size, the driver will return an error.

This table lists the values for MemoryOffset:

Value	Offset Produced
'0'	0
'1'	0x4000000
'2'	0x8000000
'3'	0xC000000

Board Interrupts

The PCI-5565 board can generate PCI interrupts in response to network events that have been broadcast from other nodes, or in response to error conditions. For example, you can

configure two Simulink Real-Time Simulink models, one as master, and one as a slave of the broadcast node in the master Simulink Real-Time model. In such a configuration, the broadcast node interrupt triggers the model's time steps.

To display the interrupt mode fields, type:

```
node.Interface.Interrupts
```

```
ans =  
    LocalMemoryParity: 'off'  
    MemoryWriteInhibited: 'off'  
        LatchedSyncLoss: 'off'  
            RXFifoFull: 'off'  
    RXFifoAlmostFull: 'off'  
        BadData: 'off'  
    PendingInit: 'off'  
    RoguePacket: 'off'  
    ResetNodeRequest: 'off'  
    PendingInt3: 'off'  
    PendingInt2: 'off'  
    PendingInt1: 'off'
```

Each field corresponds to a bit in the LIER register of the PCI-5565 board. Each bit enables the specified interrupt source on the PCI-5565 board. Refer to the PCI-5565 product documentation for further details on this register.

To enable a node to generate a network interrupt source, add the 5565 broadcast block to a model (for example, the master model). This block issues network interrupts at the model sample rate. Correspondingly, to enable other nodes of the network (for example, the slaves) to accept broadcast interrupts from the model, configure the slave model to expect the broadcast interrupt.

The following procedure describes how to configure an entire Simulink Real-Time model to accept a broadcast interrupt from a PCI-5565 board. See GE Fanuc 5565 broadcast for a description of the **Interrupt parameter** value that the Simulink Real-Time model expects.

1 From the MATLAB Command Window, type

```
tg = slrt;  
getPCIInfo(tg, 'installed')
```

This command lists board information for the installed PCI devices that the Simulink Real-Time software knows about.

- 2 Find the IRQ specified for the PCI-5565 board.

This is the interrupt source number you need to specify in the **Real-Time interrupt source** field of the **Simulink Real-Time Options** pane.

- 3 Edit your script and add a line like the following.

```
node.Interface.Interrupts.PendingInt1='on'
```

This line directs the model to expect an interrupt. It assumes that the value of the 5565 broadcast block **Interrupt parameter** is 1.

- 4 From the MATLAB Command Window, type the name of your Simulink model.

The Simulink model appears.

- 5 Select **Simulation > Model Configuration Parameters**
- 6 Select node **Code Generation**.
- 7 Select node **Simulink Real-Time Options**.
- 8 Set the **Execution mode** field to **Real-Time**.
- 9 Click the **Real-Time interrupt source** list.
- 10 Select the interrupt source number to which the board is set.
- 11 Click the **I/O board generating the interrupt** list and select **GE_Fanuc (VMIC)_PCI-5565** from the list.
- 12 Click **OK**.

Note: If you have a larger model, and you want to localize control of the interrupt within that model, use the **IRQ Source** block from the **Asynchronous Event** sublibrary.

Board Node ID

The jumpers of the PCI-5565 board specify the board node ID. Correspondingly, you can also configure the PCI-5565 block with the board node ID using the **Interface.NodeID** field. Enter values according to the following:

NodeID Value	Description
'any'	Allows the PCI-5565 driver to work with a PCI-5565 node regardless of the PCI-5565 board node ID jumper setting

NodeID Value	Description
value from '0' to '255'	Specifies the particular PCI-5565 node that the driver must look for. If this value does not match the jumpered value on the PCI-5565 board, the driver returns an error.

The default value of 'any' meets requirements in most instances. However, you might want to specify a particular NodeID value if you have multiple PCI-5565 boards in your system and you want to identify the driver for a particular node.

GE Intelligent Platforms Shared Memory

Simulink Real-Time supports high-speed fiber optic reflective memory boards manufactured by Abaco (www.abaco.com), which acquired the intellectual property of GE Intelligent Platforms and SBS Technologies.

The Simulink Real-Time software uses a model for shared memory that includes Simulink blocks, for the shared memory drivers, and MATLAB structures for defining shared memory and node initialization partitions.

Note: The Simulink Real-Time SBS25x0 driver does not fully support node-to-node network configuration. In most cases, a shared memory hub is required to use the SBS Shared driver blocks. If you have additional questions, please contact MathWorks Technical Support.

Create GE Intelligent Platforms Shared Partitions

To use the Simulink Real-Time SBS Broadcast Memory shared memory blocks to read, write, pack, or unpack data, you must define a partition structure. SBS Broadcast Memory shared memory drivers use MATLAB structures to define shared memory partitions. A partition structure describes how you want to allocate (or partition) the shared memory. The Simulink Real-Time software allocates shared memory with bundles of data that are packed into memory partitions. The following SBS Broadcast Memory blocks use shared memory partition structures:

- SBS25x0 read and SBS25x0 write
- Shared Memory Pack and Shared Memory Unpack

After you define the shared memory partitions, you can add SBS Broadcast Memory shared memory driver blocks to your Simulink model. Create a shared memory structure in one of the following ways. See “GE Intelligent Platforms Shared Partition Structure” on page 24-19 for the complete list of fields for the structure.

The following description refers to the `smpartsbs25x0` command. Type

```
help smpartsbs25x0
```

for a description of the command.

- Using the `smpartsbs25x0` command at the MATLAB Command Window, create a default partition structure. For example, type

```
x=smpartsbs25x0  
  
>> smpartsbs25x0  
SBS25x0 Shared Memory Partition  
Shared-Memory partition  
Total Bytes in partition = 4  
Starting Address = 0x0  
Number of segments = 1
```

To get the contents of `x`, type

```
>> get(x)  
  
ans =  
    Address: '0x0'
```

```

    Type: 'uint32'
Alignment: '4'
    Size: '[ 1 ]'
    WIT: 'off'

```

- At the MATLAB Command Window, create a user-defined partition structure. The easiest way to do this is to create a script file, partially define a structure, load that script into the MATLAB workspace. For example

```

Partition(1).Address='0x5000';
Partition(1).Type='int8';
Partition(1).Size='10';
Partition(2).Type='uint16';
Partition(2).Size='5';
Partition(3).Type='uint8';
Partition(3).Size='1';
Partition(3).Alignment='8';
Partition(4).Type='double';
Partition(4).Size='3';

```

To get the contents of x with these settings, type

```

>> x=smpartsbs25x0(Partition)
SBS25x0 Shared Memory Partition
Shared-Memory partition
  Total Bytes in partition = 16
  Starting Address = 0x5000
  Number of segments = 4

```

This example defines a partition with four segments.

- The **Address** field is optional. Only specify this field for the first segment of a partition. The elements of a partition are defined as a continuous memory block from the first address. The following segments extrapolate their addresses from the first segment. If you have fragmented memory, use multiple partitions and SBS Broadcast Memory read/write blocks to work with the memory.
- The **Type** and **Size** fields are required for all fields in the partition structure.
- The **Alignment** value is optional. It is '4' by default, which forces segments that do not have alignment specifications to start on 4 byte (32 bit) boundaries. In this partition, the third segment (**Partition(3)**) has an alignment of '8'.
- The base addresses of subsequent segments are fully defined by the data type, size, and alignment of the preceding segment.

You can then call the `smpartsbs25x0()` command to fully populate the partition structure.

Initialize GE Intelligent Platforms Shared Nodes

To use the Simulink Real-Time SBS Broadcast Memory shared memory, you must define a node initialization structure. SBS Broadcast Memory shared memory drivers use MATLAB structures to define shared memory node initialization. A node initialization structure describes the shared memory partition (see “Create GE Intelligent Platforms Shared Partitions” on page 24-14) and the SBS Broadcast Memory board configuration, including interrupt configurations. The following SBS Broadcast Memory block requires shared memory node initialization structures:

- SBS25x0 init

After you define the node initialization partition, you can add SBS Broadcast Memory shared memory driver blocks to your Simulink model. Create a shared memory structure in one of the following ways. See “GE Intelligent Platforms Shared Node Initialization Structure” on page 24-21 for the complete list of fields for the structure.

The following description refers to the `smnodesbs25x0` command. Type

```
help smnodesbs25x0
```

for a description of the command.

Using the `smnodesbs25x0` command at the MATLAB Command Window, create a default node initialization structure. For example, type

```
>> node=smnodesbs25x0
Node Definition for SBS2500/SBS2510 Broadcast Memory
```

To get the contents of `node`, type

```
>> get(node)

ans =
    TargetAbortEnable: 'off'
      LoopbackEnable: 'off'
         Node2Node: 'off'
           RXEnable: 'on'
           TXEnable: 'on'
      MemorySize: '256kByte'
         WITEnable: 'off'
  IRQ_ErrorEnable: 'off'
    IRQ_WITEnable: 'off'
```

```
Partition: []  
SlotID: 'any'
```

- At the MATLAB Command Window, create a user-defined node structure. The easiest way to do this is to create a script file, partially define a structure, load that script into the MATLAB workspace. For example

```
z.LoopbackEnable='on';  
z.Partition=x
```

To get the contents of node with these settings, type

```
>> node=smnodesbs25x0(node1)  
Node Definition for SBS2500/SBS2510 Broadcast Memory  
>> get(node)
```

```
ans =  
TargetAbortEnable: 'off'  
LoopbackEnable: 'on'  
Node2Node: 'off'  
RXEnable: 'on'  
TXEnable: 'on'  
MemorySize: '256kByte'  
WITEnable: 'off'  
IRQ_ErrorEnable: 'off'  
IRQ_WITEnable: 'off'  
Partition: [1x1 smpartsbs25x0]  
SlotID: 'any'
```

Currently, you can define values only for the fields **LoopbackEnable**, **WITEnable**, and **Partition**.

GE Intelligent Platforms Shared Partition Structure

You do not need to use all the fields of a partition initialization structure. However, knowing the possible structure fields will be helpful when you are creating the structures.

A shared memory partition structure has the following fields:

```
Address: '0x0'
      Type: 'uint32'
      Alignment: '4'
      Size: '[ 1 ]'
      WIT: 'off'
```

where

Partition Fields	Description
Address	<p>Specifies the base address (in hexadecimal) of the memory partition within the node's shared memory space. The default value is '0x0', the first location in shared memory.</p> <p>Align partition addresses on 32-bit word boundaries (for example, 0x0, 0x4, 0x8, and so forth).</p>
Type	<p>Specifies the data type of the memory segment. Specify one of the following types:</p> <ul style="list-style-type: none"> • single (IEEE Single Precision) • double (IEEE Double Precision) • uint8 • int8 • uint16 • int16 • uint32 • int32 • Boolean (a single byte represents a boolean value) <p>The default value is 'uint32'. A minimum partition size is 32 bits.</p>

Partition Fields	Description
Size	<p>Specifies the dimension and size of the memory segment. You can enter a scalar value or a value with the <code>[m,n]</code> format. The default value is <code>'1'</code>.</p> <ul style="list-style-type: none"> • scalar — Treats the Size entry as the specification of the length of a non-oriented array or vector • <code>[m,n]</code> — Treats the Size entry as an array dimension. The total number of elements in this segment is $m*n$.
Alignment	<p>If another partition precedes this partition, defines the byte alignment of this segment. Specify one of the following alignment values: <code>1</code>, <code>2</code>, <code>3</code>, <code>4</code>, or <code>8</code>. The default value is <code>'4'</code>. This value forces a double word boundary alignment for the first address of this segment.</p>
WIT	<p>Write Interrupt Table. If this partition segment receives a write request, specifies whether or not the partition generates an interrupt. Specify <code>'off'</code>, <code>'first'</code>, <code>'all'</code>, <code>'last'</code>. The default value is <code>'off'</code>.</p> <p><code>'off'</code> — Prevents the partition from generating interrupts</p> <p><code>'first'</code> — Allows a write to the first double word of the memory block to generate an interrupt.</p> <p><code>'all'</code> — Allows a write to all locations of the memory block to generate an interrupt.</p> <p><code>'last'</code> — Allows a write to only the last double word of the memory segment to generate an interrupt.</p>

GE Intelligent Platforms Shared Node Initialization Structure

You do not need to use all the fields of a node initialization structure. However, knowing the possible structure fields will be helpful when you are creating the structures.

A node initialization structure has the following fields:

```
TargetAbortEnable: 'off'
  LoopbackEnable: 'off'
    Node2Node: 'off'
      RXEnable: 'on'
      TXEnable: 'on'
    MemorySize: '256kByte'
      WITEnable: 'off'
    IRQ_ErrorEnable: 'off'
      IRQ_WITEnable: 'off'
    Partition: []
      SlotID: 'any'
```

These values interact with the Extended Control Register. Refer to the SBS Broadcast Memory product documentation for further details on registers.

Of particular note are the following register modes:

Board Modes	Description
LoopbackEnable	<p>Specifies if the Simulink Real-Time software can operate without having the shared memory network fully operational.</p> <ul style="list-style-type: none"> 'off' — Normal shared memory operation (requires operating shared memory network) 'on' — Loop back enable. This allows the Simulink Real-Time software to operate without having the shared memory network fully operational.
MemorySize	<p>Specifies the minimum memory size required. The SBS Broadcast Memory driver checks this value against the memory size of the SBS Broadcast Memory board. An SBS Broadcast Memory board has a memory size of either '64MByte' or '128MByte'. If you enter a size in this field that is larger than the actual SBS Broadcast Memory board memory size, the driver will return an error. You can enter values of:</p>

Board Modes	Description
	'256kByte' '512kByte' '1MByte' '2MByte' '4MByte' '8MByte'
Partition	Specifies the memory partition to be initialized. The node requires this value to initialize the interrupt table for the partition. This parameter is required for Simulink Real-Time configurations that will be driven by shared memory interrupts.

Board Interrupts

If you want to have an interrupt source, the SBS shared memory board can generate PCI interrupts in response to writes to memory partitions of a memory block. You define this behavior through the WIT field of the shared memory partition structure. Each partition segment has its own WIT setting.

To enable a memory location to generate an interrupt, set the WIT field as desired, then configure the Simulink Real-Time model to generate an interrupt.

The following procedure describes how to configure an entire Simulink Real-Time model to accept an interrupt from an SBS shared memory board:

- 1 From the MATLAB Command Window, type

```
tg = slrt;  
getPCIInfo(tg, 'installed')
```

This command lists board information for the installed PCI devices that the Simulink Real-Time software knows about.

- 2 If you have multiple SBS shared memory boards, find the board ID for which you want to define the interrupt.
- 3 Find the IRQ specified for your SBS25x0 board.

This is the interrupt source number you need to specify in the **Real-Time interrupt source** field of the **Simulink Real-Time Options** pane.

- 4 From the MATLAB Command Window, type the name of your Simulink model.

The Simulink model appears.

- 5 Select **Simulation > Model Configuration Parameters**
- 6 Select node **Code Generation**.
- 7 Select node **Simulink Real-Time Options**.
- 8 Set the **Execution mode** field to **Real-Time**.
- 9 Click the **Real-Time interrupt source** list.
- 10 Select the interrupt source number to which the board is set.
- 11 Click the **I/O board generating the interrupt** list and select the SBS board ID associated with the IRQ:

SBS_25x0_ID_0x100
SBS_25x0_ID_0x101
SBS_25x0_ID_0x102
SBS_25x0_ID_0x103

- 12 If your system has multiple boards, at the **PCI slot (-1: autosearch)** parameter, specify the PCI slot that contains the board you are configuring for interrupts.
- 13 Click **OK**.

Create Curtiss-Wright Shared Partitions

The Simulink Real-Time software uses a model for reflective memory (also known as shared memory) that includes Simulink blocks for shared memory driver functions and MATLAB structures to define node initialization and shared memory partitions. This topic describes Simulink Real-Time support of the Systran[®] SCRAMNet+ SC150 board.

To use the Simulink Real-Time Systran SCRAMNet+ SC150 shared memory blocks, you must define shared memory partition structures. A partition structure describes how you want to allocate (partition) the shared memory. The Simulink Real-Time software allocates shared memory as segments of data that are packed into memory regions or partitions. Along with the Shared Memory Pack and Shared Memory Unpack blocks, the following SCRAMNet+ SC150 blocks use shared memory partition structures:

- Systran SC150 read
- Systran SC150 write
- Systran SC150 rearm

After defining the shared memory partitions, you can add SCRAMNet+ SC150 shared memory driver blocks to your Simulink model. See “Curtiss-Wright Shared Partition Structure” on page 24-27 for the complete list of fields in a partition structure.

The following description refers to the `completepartitionstruct` command. Type

```
help completepartitionstruct
```

for more information.

- Create a partition structure in one of the following ways. Using the `completepartitionstruct` command at the MATLAB Command Window, create a default partition structure. For example, type

```
Partition = completepartitionstruct([], 'scramnet')
```

```
Partition =  
    Address: '0x0'  
    Type: 'uint32'  
    Size: '1'  
    Alignment: '4'  
    RIE: 'off'  
    TIE: 'off'  
    ExtTrigger1: 'off'
```

```

ExtTrigger2: 'off'
  HIPRO: 'off'
  Internal: [1x1 struct]

```

- At the MATLAB Command Window, create a user-defined partition structure. The easiest way to do this is to create a script file, partially define a structure, load that script into the MATLAB workspace, and supplement the resulting structure with a call to the `completepartitionstruct` function. For example

```

Partition(1).Address='0x5000';
Partition(1).Type='int8';
Partition(1).Size='10';
Partition(2).Type='uint16';
Partition(2).Size='5';
Partition(3).Type='double';
Partition(3).Size='3';
Partition(4).Type='uint8';
Partition(4).Size='[2, 3]';

```

This example defines a partition with four segments.

- The **Address** field is optional. Only specify this field for the first segment of a partition. The elements of a partition are defined as a continuous memory block from the first address. The function extrapolates segment addresses from the first segment definition. If you have or require fragmented memory, use multiple partitions.
- The **Type** and **Size** fields are required for all segments in the partition structure.
- The **Alignment** value is optional. It is '4' by default. This value forces segments that do not have alignment specifications to start on 4 byte (32-bit) boundaries.
- The base addresses of subsequent segments are defined by the data type, size, and alignment of the preceding segment.
- Call the `completepartitionstruct()` command to fully populate the partition structure.

```

Partition = completepartitionstruct(Partition,'scramnet');

```

Initialize Curtiss-Wright Shared Nodes

In addition to shared memory partitions, you must also define a node initialization structure before using the SCRAMNet+ SC150 shared memory blocks. A node initialization structure describes the shared memory partitions (see “Create Curtiss-Wright Shared Partitions” on page 24-24) and the SCRAMNet+ SC150 board configuration, including interrupt settings, if used. The `Systran SC150 init` block requires a shared memory node initialization structure.

After defining the node initialization structure, you can add SCRAMNet+ SC150 shared memory driver blocks to your Simulink model. See “Curtiss-Wright Shared Node Initialization Structure” on page 24-32 for the complete list of fields in a node initialization.

The following description refers to the `completenodestruct` command. Type

```
help completenodestruct
```

for more information.

- Create a node initialization structure in one of the following ways. Using the `completenodestruct` command at the MATLAB Command Window, create a default node initialization structure. For example, type

```
node=completenodestruct([], 'scramnet')
```

```
node =
```

```
    Interface: [1x1 struct]  
    Partitions: [1x1 struct]
```

- Now modify the structure fields to meet your requirements. For example:

```
node.interface.NodeID = '128';  
node.Partitions = Partition;
```

- A user-defined node structure, created with MATLAB code or from the MATLAB Command Window and supplement the resulting structure with a call to the `completenodestruct` function. For example:

```
node.Interface.NodeID = '128';  
node.Partitions = Partition;  
node = completenodestruct(node, 'scramnet');
```

Curtiss-Wright Shared Partition Structure

A shared memory partition structure has the following fields. You do not need to use all the fields of a partition or node initialization structure. However, knowing the possible structure fields will be helpful when you are setting up to use shared memory.

```
Address: '0x0'  
Type: 'uint32'  
Size: '1'  
Alignment: '4'  
RIE: 'off'  
TIE: 'off'  
ExtTrigger1: 'off'  
ExtTrigger2: 'off'  
HIPRO: 'off'  
Internal: [1x1 struct]
```

where

Partition Fields	Description
Address	Specifies the base address (in hexadecimal) of the memory partition within the node's shared memory space. The default value is '0x0', the first location in shared memory. Note that the base address is byte aligned.
Type	Specifies the data type of the memory segment. Specify one of the following types: <ul style="list-style-type: none">• double• float• uint8• int8• uint16• int16• uint32• int32• boolean (a single byte represents a boolean value) The minimum partition size is 32 bits.

Partition Fields	Description
	The default value is 'uint32'.
Size	<p>Specifies the dimension and size of the memory segment. You can enter a scalar value or a value with the [m,n] format. The default value is '1'.</p> <ul style="list-style-type: none"> • scalar — Treats the Size entry as the specification of the length of a non-oriented array or vector • [m,n] — Treats the Size entry as an array dimension. The total number of elements in this segment is m*n.
Alignment	<p>Specifies the byte alignment of the next partition (if one is defined). Enter alignment value in bytes: 1, 2, 3, 4. The alignment value defines the end of the current segment, and therefore the beginning alignment of the next segment. The default value is '4', forcing a double word boundary alignment. See “Alignment Examples” on page 24-30.</p>
RIE	<p>Specifies whether or not this partition can receive interrupts (Receive Interrupt Register (RIE)). Specify 'off', 'first', 'all', 'last'. The default value is 'off'.</p> <p>'off' — Prevents the partition from receiving interrupts</p> <p>'first' — Allows only the first double word of the memory segment to be marked with the corresponding Auxiliary Control RAM bit.</p> <p>'all' — Allows all memory locations of the memory segment to be marked with the corresponding Auxiliary Control RAM bit.</p> <p>'last' — Allows only the last double word of the memory segment to be marked with the corresponding Auxiliary Control RAM bit.</p>

Partition Fields	Description
TIE	<p>Specifies whether or not this partition can transmit interrupts (Transmit Enable (TIE)). Specify 'off', 'first', 'all', 'last'. The default value is 'off'.</p> <p>'off' — Prevents the partition from transmitting interrupts</p> <p>'first' — Allows only the first double word of the memory segment to be marked with the corresponding Auxiliary Control RAM bit.</p> <p>'all' — Allows all memory locations of the memory segment to be marked with the corresponding Auxiliary Control RAM bit.</p> <p>'last' — Allows only the last double word of the memory segment to be marked with the corresponding Auxiliary Control RAM bit.</p>
ExtTrigger1	<p>If this partition receives a write access, specifies whether or not this partition can generate a trigger signal to an external connector. Specify 'off', 'first', 'all', 'last'. The default value is 'off'.</p> <p>'off' — Prevents the partition from generating signals</p> <p>'first' — Allows only the first double word of the memory segment to be marked with the corresponding Auxiliary Control RAM bit.</p> <p>'all' — Allows all memory locations of the memory segment to be marked with the corresponding Auxiliary Control RAM bit.</p> <p>'last' — Allows only the last double word of the memory segment to be marked with the corresponding Auxiliary Control RAM bit.</p>

Partition Fields	Description
ExtTrigger2	<p>If this partition receives a write access, specifies whether or not this partition can generate a trigger signal to an external connector. Specify 'off', 'first', 'all', 'last'. The default value is 'off'.</p> <p>'off' — Prevents the partition from generating signals</p> <p>'first' — Allows only the first double word of the memory segment to be marked with the corresponding Auxiliary Control RAM bit.</p> <p>'all' — Allows all memory locations of the memory segment to be marked with the corresponding Auxiliary Control RAM bit.</p> <p>'last' — Allows only the last double word of the memory segment to be marked with the corresponding Auxiliary Control RAM bit.</p>
HIPRO	<p>Specifies whether or not the elements in this partition can be transmitted as one network message. Specify 'off', or 'on'. The default value is 'off'.</p> <p>'off' — Prevents the partition from transmitting the elements as one message</p> <p>'on' — Allows the partition to transmit the elements as one message</p>
Internal	Reserved for internal use.

Alignment Examples

This example shows the shared memory map with default alignment values.

```
Partition1(1).Type='int32';
Partition1(1).Size='1';

Partition1(2).Type='boolean';
Partition1(2).Size='1';

Partition1(3).Type='uint32';
Partition1(3).Size='1';
Partition1 = completepartitionstruct(Partition1, 'scramnet');
```



This example shows the shared memory map with alignment value changed from 4 to 1 in the second partition.

```
Partition1(1).Type='int32';  
Partition1(1).Size='1';  
Partition1(1).Alignment='4';  
  
Partition1(2).Type='boolean';  
Partition1(2).Size='1';  
Partition1(2).Alignment='1';  
  
Partition1(3).Type='uint32';  
Partition1(3).Size='1';  
Partition1 = completepartitionstruct(Partition1,'scramnet');
```

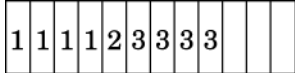

This example shows the shared memory map with alignment value changed from 4 to 2 in the second partition.

```
Partition1(1).Type='int32';  
Partition1(1).Size='1';  
Partition1(1).Alignment='4';  
  
Partition1(2).Type='boolean';  
Partition1(2).Size='1';  
Partition1(2).Alignment='2';  
  
Partition1(3).Type='uint32';  
Partition1(3).Size='1';  
Partition1 = completepartitionstruct(Partition1,'scramnet');
```



Curtiss-Wright Shared Node Initialization Structure

A node initialization structure has the following fields:

```
Interface: [1x1 struct]
Partitions: [1x1 struct]
```

where

Node Structure Fields	Description
Interface	<p>Specifies settings for the board Control/Status Register (CSR). The Interface structure has the following fields. Refer to the SCRAMNet + SC150 product documentation for a description of the CSR and its operation modes.</p> <ul style="list-style-type: none"> • Mode — Configures board modes (see “Board Mode” on page 24-32) • Timeout — Enables the board to set the timeout value (see “Board Timeout” on page 24-34) • DataFilter — Controls the data filtering operation (see “Board Data Filter” on page 24-34) • VirtualPaging — Controls the board virtual paging operation (see “Virtual Paging” on page 24-35) • Interrupts — Enables the board to generate and receive interrupts from the network (see “Board Interrupts” on page 24-35) • Internal — Reserved for internal use
Partitions	Stores the shared memory segments (see “Create Curtiss-Wright Shared Partitions” on page 24-24)

Board Mode

The SCRAMNet+ SC150 board has a number of modes that you can set through the `Interface.Mode` field. The Interface Mode fields set the corresponding bits in the CSR. To display the board mode fields, type

```
>> node.Interface.Mode
```

```

ans =
    NetworkCommunicationsMode: 'TransmitReceive'
        InsertNode: 'on'
    DisableFiberOpticLoopback: 'on'
        EnableWireLoopback: 'off'
    DisableHostToMemoryWrite: 'off'
        WriteOwnSlotEnable: 'off'
        MessageLengthLimit: '256'
    VariableLengthMessagesOnNetwork: 'off'
        HIPROEnable: 'off'
        MultipleMessages: 'on'
    NoNetworkErrorCorrection: 'on'
    MechanicalSwitchOverride: 'on'
        DisableHoldoff: 'on'

```

These modes have the following values:

Field	Values	Default	CSR
NetworkCommunications Mode	'none', 'receiveonly', 'transmitonly', 'transmit receive'	'transmit receive'	CSR3[8..15]
InsertNode	'off', 'on'	'on'	CSR0[0..1]
DisableFiberOptic Loopback	'off', 'on'	'on'	CSR2[6]
EnableWire Loopback	'off', 'on'	'off'	CSR2[7]
DisableHost ToMemory Write	'off', 'on'	'off'	CSR2[8]
WriteOwnSlotEnable	'off', 'on'	'off'	CSR2[9]
Message LengthLimit	'256', '1024'	'256'	CSR2[11]
Variable Length MessagesOn Network	'off', 'on'	'off'	CSR2[12]
HIPROEnable	'off', 'on'	'off'	CSR2[13]
Multiple Messages	'off', 'on'	'on'	CSR2[14]
NoNetwork Error Correction	'off', 'on'	'on'	CSR2[15]
Mechanical Switch Override	'off', 'on'	'on'	CSR8[11]
Disable Holdoff	'off', 'on'	'on'	CSR8[11]

Board Timeout

The SCRAMNet+ SC150 board allows you to set the network timeout through the `Interface.Timeout` field. The `Interface.Timeout` fields set the corresponding bits in the CSR.

To display the timeout fields, type

```
>> node.Interface.Timeout
ans =
      NumOfNodesInRing: '2'
      TotalCableLengthInM: '2'
```

These fields have the following values:

Field	Values	Default	CSR
NumOfNodes InRing	'0' .. '255'	'2'	CSR5
TotableCable LengthInM	'0' .. 'n'	'2'	CSR5

Refer to the SCRAMNet+ SC150 product documentation for a description of these fields.

Board Data Filter

The SCRAMNet+ SC150 board allows you to set the data filter operation through the `Interface.DataFilter` field. The `Interface.DataFilter` fields set the corresponding bits in the CSR.

```
>> node.Interface.DataFilter
ans =
      EnableTransmitDataFilter: 'off'
      EnableLower4KBytesForDataFilter: 'off'
>>
```

These fields have the following values:

Field	Values	Default	CSR
Enable TransmitData Filter	'off', 'on'	'off'	CSR0[10]
EnableLower4KBytesFor DataFilter	'off', 'on'	'off'	CSR0[11]

Virtual Paging

The SCRAMNet+ SC150 board allows you to set the bits of the Virtual Paging Register operation through the `Interface.VirtualPaging` field. The `Interface.VirtualPaging` fields set the corresponding bits in the CSR.

```
>> node.Interface.VirtualPaging
ans =
  VirtualPagingEnable: 'off'
  VirtualPageNumber: '0'
```

These fields have the following values:

Field	Values	Default	CSR
VirtualPagingEnable	'off', 'on'	'off'	CSR12[0]
VirtualPage Number	'0'..'2047'	'0'	CSR12[5..15]

Board Interrupts

The SCRAMNet+ SC150 board allows you to specify the interrupt sources transmitted and received between the nodes of the network. You can set these bits through the `Interface.Interrupts` field. The `Interface.Interrupts` fields set the corresponding bits in the CSR.

```
>> node.Interface.Interrupts
ans =
  HostInterrupt: 'off'
  InterruptOnMemoryMaskMatch: 'off'
  OverrideReceiveInterrupt: 'off'
  InterruptOnError: 'off'
  NetworkInterrupt: 'off'
  OverrideTransmitInterrupt: 'off'
  InterruptOnOwnSlot: 'off'
  ReceiveInterruptOverride: 'off'
```

These fields have the following values:

Field	Values	Default	CSR
HostInterrupt	'off', 'on'	'off'	CSR0[3]
InterruptOn MemoryMask Match	'off', 'on'	'off'	CSR0[5]

Field	Values	Default	CSR
Override Receive Interrupt	'off', 'on'	'off'	CSR0[6]
InterruptOn Error	'off', 'on'	'off'	CSR0[7]
Network Interrupt	'off', 'on'	'off'	CSR0[8]
Override Transmit Interrupt	'off', 'on'	'off'	CSR0[9]
InterruptOn OwnSlot	'off', 'on'	'off'	CSR2[10]
Receive Interrupt Override	'off', 'on'	'off'	CSR8[10]

Video, XCP

Video Image Processing

- “Process Video Images Using Simulink Real-Time” on page 25-2
- “USB Video Display on Development Computer” on page 25-3
- “USB Video Display on Target Computer” on page 25-4
- “Camera Link Camera Display on Development Computer” on page 25-5
- “Camera Link Camera Display on Target Computer” on page 25-7
- “Acquire Images from Camera Link Cameras” on page 25-8
- “Camera Link Camera Triggering” on page 25-9
- “Serial Camera Configuration” on page 25-13
- “Install BitFlow Neon-CLB Support” on page 25-15

Process Video Images Using Simulink Real-Time

The Simulink Real-Time software supports webcams compliant with the USB Video Class (UVC) standard and cameras compliant with the Automated Imaging Association Camera Link[®] standard.

Note: UVC-compliant cameras are often referred to as "driverless webcams". For more information, see your camera documentation.

Using blocks from the Simulink Real-Time Video library, on your target computer, you can do the following:

- Acquire real-time video frames from cameras connected to the target computer.
- Display the real-time image on the target computer monitor.
- Process or reduce the real-time image, for instance to choose a region of interest.
- Compress video frames acquired on the target computer.
- Stream video frames acquired on the target computer to the development computer.

Using blocks from the Computer Vision System Toolbox[™] or Image Processing Toolbox[™], on your development computer, you can do the following:

- Receive images from the target computer.
- Decompress video frames on the development computer.
- Process or reduce images.
- Display images on the development computer.

USB Video Display on Development Computer

The following workflow acquires and displays video frames using a USB Video Class (UVC) compliant webcam. To view the images on the development computer, compress the video frames on the target computer and transmit them to the development computer. You then decompress and display the video frames.

- 1** Enable USB general support through the target computer BIOS. See “BIOS Settings”.
- 2** Acquire a USB Video Class (UVC) compliant webcam, and then connect it to the target computer USB port.
- 3** To query the available camera configurations, add the `USB Video Device List` block.
- 4** Add the image input block `From USB Video Device` to the portion of the model that runs on the target computer. Configure the block as required.
- 5** If your USB camera does not support on-chip JPEG compression, add the `JPEG Compression` block to the target computer portion. Connect this block to the output of the image input block.
- 6** Add the `Image Transmit` block to the target computer portion. Connect this block to the output of the compression block. Configure the block to transmit frames to the development computer.
- 7** Add the `Image Receive` block to the portion of the model that runs on the development computer. Configure the block to receive frames from the target computer.
- 8** Add the `JPEG Decompression` block to the development computer portion. Connect this block to the output of the `Image Receive` block.
- 9** Add the `To Video Display` block from the Computer Vision System Toolbox to the development computer portion.
- 10** Build and download the target computer portion of the model to the target computer.
- 11** Run the development computer portion of the model on the development computer.

USB Video Display on Target Computer

The following workflow acquires and displays video frames using a USB Video Class (UVC) compliant webcam. To view the images on the target computer, use a **Video Display** block.

- 1 Enable USB general support through the target computer BIOS. See “BIOS Settings”.
- 2 Acquire a USB Video Class (UVC) compliant webcam, and then connect it to the target computer USB port.
- 3 To query the available camera configurations, add the **USB Video Device List** block.
- 4 Add the image input block **From USB Video Device** to the portion of the model that runs on the target computer. Configure the block as required.

Record the setting of the **Image signal** parameter.

- 5 Add the **Video Display** block. Set its **Image signal** parameter to match the corresponding setting in the **From USB Video Device** block.
- 6 Build and download the target computer portion of the model to the target computer.
- 7 Execute the model on the target computer.

Camera Link Camera Display on Development Computer

The following workflow acquires and displays video frames using a camera that is compliant with the Camera Link standard. To view the images on the development computer, compress the video frames on the target computer and transmit them to the development computer. You then decompress and display the video frames.

- 1 Install the BitFlow Neon-CLB board in a PCI Express® x4 or wider slot in the target computer.
- 2 Install the BitFlow™ Neon-CLB Support Package and the BitFlow SDK. See “Install BitFlow Neon-CLB Support” on page 25-15.
- 3 Acquire a monochrome digital camera that is compliant with Camera Link. The camera must have a configuration file in the BitFlow SDK that specifies a free-running or triggered mode.

To configure the BitFlow Neon-CLB board, the **NEON BitFlow Image Input** block requires the BitFlow SDK and a configuration file for your specific camera. If the SDK does not contain the required file, contact your BitFlow representative. You cannot proceed without this file.

- 4 Attach the camera to the BitFlow Neon-CLB board in the target computer.
- 5 Add the **NEON BitFlow Image Input** block, available in the Simulink Real-Time Video library, to the portion of the model that runs on the target computer. Configure the block as required.
- 6 Add the **JPEG Compression** block to the target computer portion. Connect this block to the output of the image input block.
- 7 Add the **Image Transmit** block to the target computer portion. Connect this block to the output of the compression block. Configure the block to transmit frames to the development computer.
- 8 Add the **Image Receive** block to the portion of the model that runs on the development computer. Configure the block to receive frames from the target computer.
- 9 Add the **JPEG Decompression** block to the development computer portion. Connect this block to the output of the **Image Receive** block.
- 10 Add the **To Video Display** block from the Computer Vision System Toolbox to the development computer portion.
- 11 Build and download the target computer portion of the model to the target computer.

- 12** Run the development computer portion of the model on the development computer.

Camera Link Camera Display on Target Computer

The following workflow acquires and displays video frames using a camera that is compliant with the Camera Link standard. To view the images on the target computer, use a `Video Display` block.

- 1 Install the BitFlow Neon-CLB board in a PCI Express x4 or wider slot in the target computer.
- 2 Install the BitFlow Neon-CLB Support Package and the BitFlow SDK. See “Install BitFlow Neon-CLB Support” on page 25-15.
- 3 Acquire a monochrome digital camera that is compliant with Camera Link. The camera must have a configuration file in the BitFlow SDK that specifies a free-running or triggered mode.

To configure the BitFlow Neon-CLB board, the `NEON BitFlow Image Input` block requires the BitFlow SDK and a configuration file for your specific camera. If the SDK does not contain the required file, contact your BitFlow representative. You cannot proceed without this file.

- 4 Attach the camera to the BitFlow Neon-CLB board in the target computer.
- 5 Add the `NEON BitFlow Image Input` block, available in the Simulink Real-Time Video library, to the target-side model. Configure the block as required.
- 6 Add the `Video Display` block. Set its **Image signal** parameter to `Single multidimensional signal`.
- 7 Build and download the target-side model to the target computer.
- 8 Execute the model on the target computer.

Acquire Images from Camera Link Cameras

You can use the NEON BitFlow Image Input block to acquire images from cameras that support the Automated Imaging Association Camera Link interface standard. This block supports the BitFlow Neon-CLB board (see www.bitflow.com).

Be familiar with the following information:

- Video capture procedures
- Camera Link interface standard
- Manufacturer instructions for installing the BitFlow Neon-CLB board on the target computer
- Instructions for installing the BitFlow SDK. See “Install BitFlow Neon-CLB Support” on page 25-15.
- Serial command codes for your particular camera model. See “Serial Camera Configuration” on page 25-13.

The Simulink Real-Time product contains the following example that illustrates how to acquire images from a camera connected to the BitFlow Neon-CLB board.

“Image Capture with Camera Link® and Bitflow™ Neon-CLB Frame Grabber”

Camera Link Camera Triggering

The NEON BitFlow Image Input block interacts with the frame grabber and camera using four triggering modes set in the camera configuration file:

- **Free Running.** The camera and frame grabber run continuously. When the camera finishes an exposure, the frame grabber board copies the image to target memory using DMA and signals a frame completion interrupt. Upon receiving the interrupt, the model runs and performs image processing.

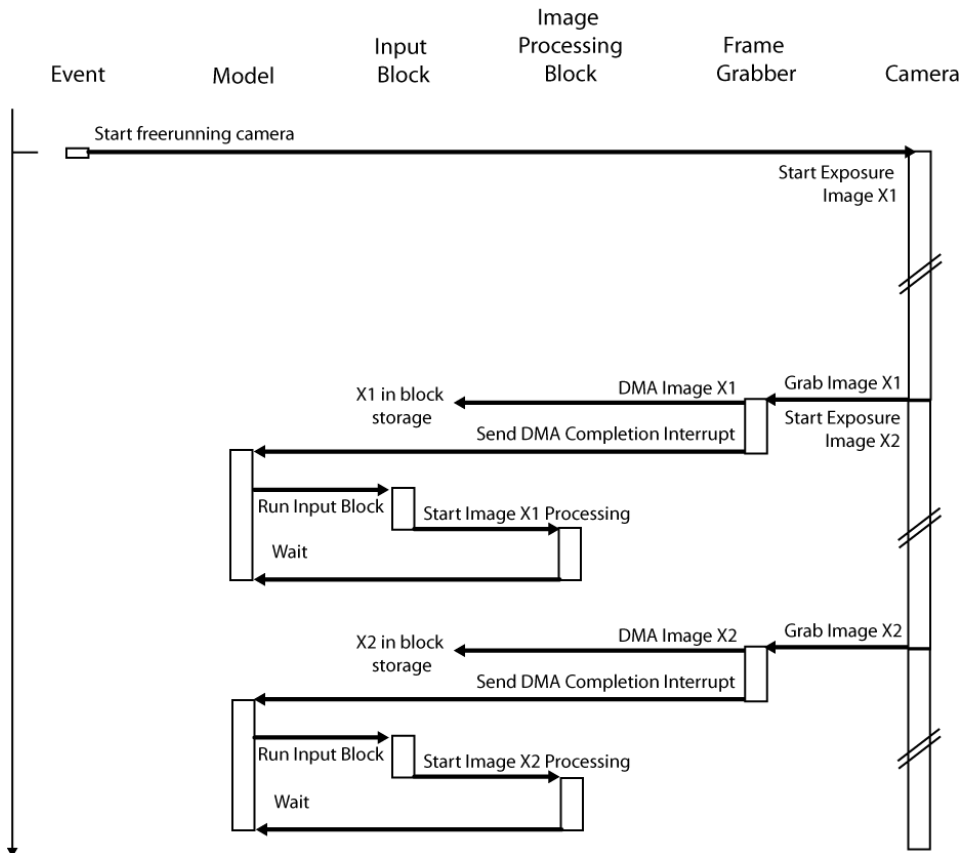

Before the next DMA completion interrupt, the model must complete image processing. Otherwise, the CPU becomes overloaded.

If the model requires heavy image processing, create a multirate, multitasking model that samples every N th image. Place the image input block at the top level with a sample time of T_s . Construct an atomic subsystem for image processing. Assign it a sample time of $T_s * 2$ (or whatever factor N allows the subsystem to sample every N th image). Connect the output of the image input block to the input port of the subsystem through a rate transition block.

The example “Image Capture with Camera Link® and Bitflow™ Neon-CLB Frame Grabber” shows such a model. The subsystem runs at $T_s * 3$, sampling every third image. The model is configured for a large format camera where the Jpeg Compression and Image Transmit blocks take more than T_s to complete.

- **Timer Triggered.** The target computer system timer starts the model. When the model runs, it simultaneously starts a camera exposure and begins to process the image captured during the previous time step. When the camera finishes the exposure, the frame grabber copies the image to target memory using DMA for processing in the next time step.

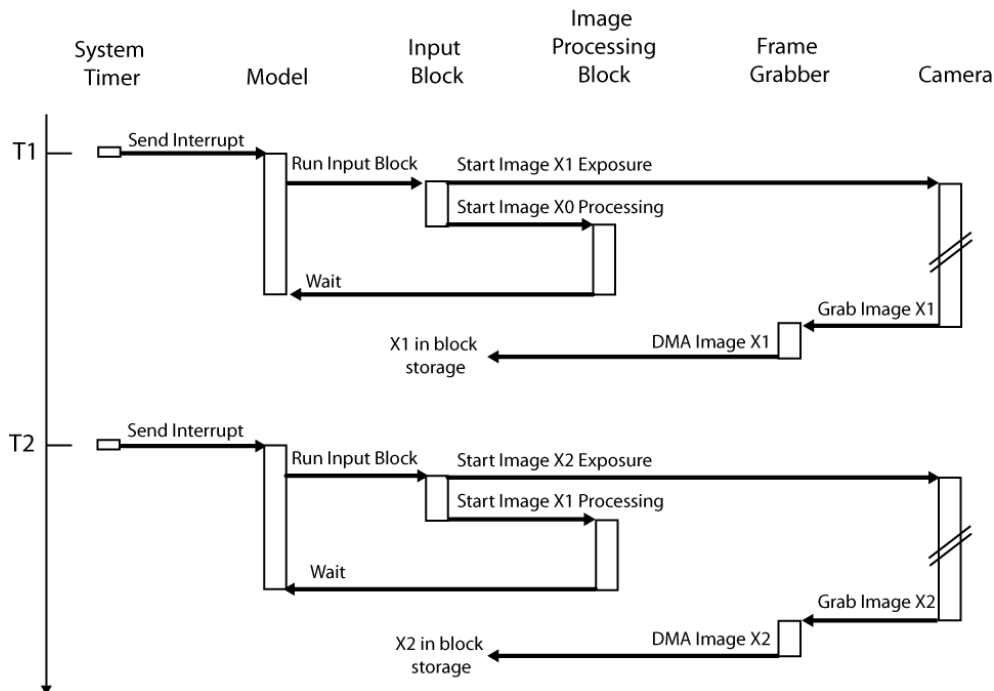

- **Differential Trigger.** A rising edge on the differential trigger input triggers the camera. When the camera finishes the exposure, the frame grabber copies the image to target memory using DMA, and signals a frame completion interrupt. Upon receiving the interrupt, the model runs and performs image processing.

Camera Link cameras are designed to respond to one of four camera control lines (CC1 to CC4) coming from the frame grabber. The required control line is in the triggered-mode configuration file for the camera. Connect the external trigger to the frame grabber trigger input.

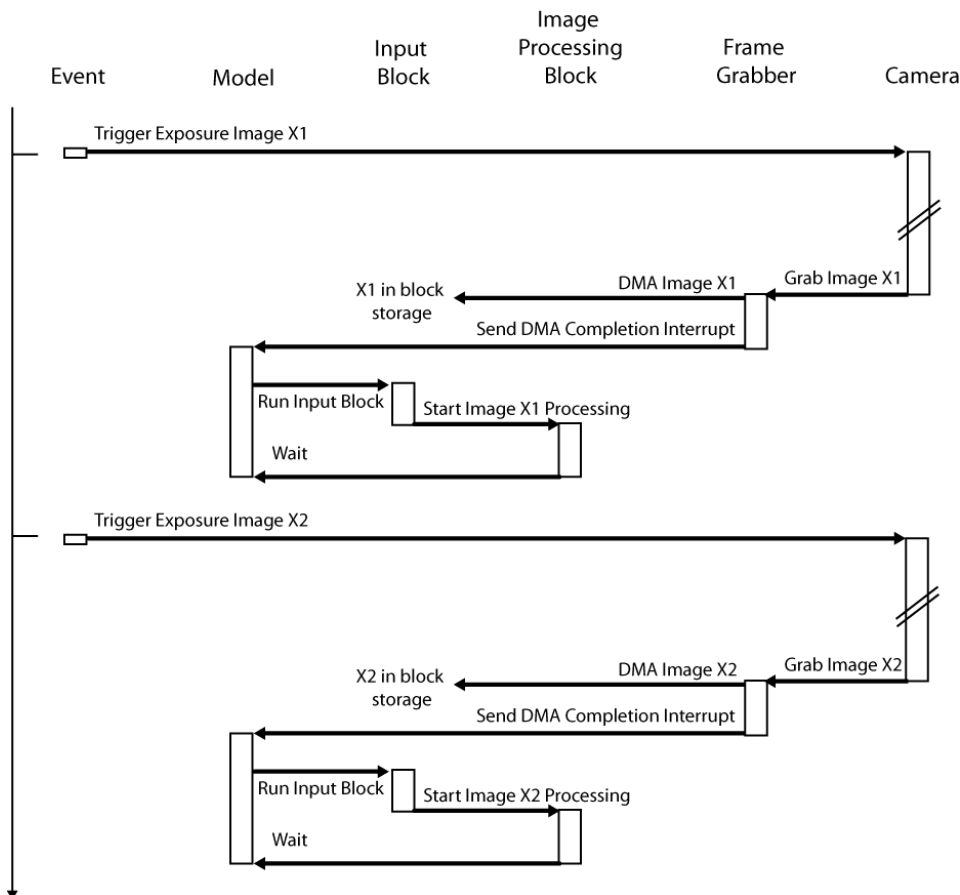

- **TTL Trigger.** A rising edge on the TTL trigger input triggers the camera. The model runs from the frame completion interrupt.
- **Opto Trigger.** A rising edge on the Opto trigger input triggers the camera. The model runs from the frame completion interrupt.

The camera configuration file puts the frame grabber into triggered mode, but does not put the camera into that mode. To set the camera to triggered mode, send a command to the camera. See “Serial Camera Configuration” on page 25-13.

The camera configuration file determines whether you can use the block mask to switch the trigger mode to another mode, such as **Free Running**. You could need to contact BitFlow for a camera configuration file for the mode that you want.

Serial Camera Configuration

To enter a serial command for the camera, enter it without quotation marks in the **Camera configuration serial command** text box.

Enter multiple commands as one line without white space.

Each camera manufacturer has a serial command set documented in the manual for each camera or family of cameras. Each command set is different from any other. For example, suppose you want to put a camera from the given series into triggered mode and to set the shutter time to 1 ms. Use these settings and serial setup strings.

Camera Series	Mask Settings	Serial Setup
CIS VCC G21	9600 baud 8 bits No parity	000000W004001\r 000000W002005\r
Pulnix TM1400	9600 baud 8 bits No parity	:SA5\r
Sony XCL	38,400 baud 8 bits No parity	SHUTTER 7\r TRG_MODE 1\r
Cohu 7800	9600 baud 8 bits No parity	\002\0377cE2,10chk\003 \002\0377cM2chk\003 \002\0377T0,1chk\003 <i>chk</i> is a checksum for the given portion of the message.

For your camera, find the required command codes in the manufacturer documentation for that specific camera. If those codes are not in the manual, contact the camera manufacturer.

Some cameras return a success or failure value in response to the serial command. The image input block dialog box includes a check box to allow the software to display such values. Some responses include non-printable control characters, displayed as C escape sequences.

Escape Sequence	Control Character	Definition
\r	CR	Carriage Return
\002	STX	Start of Text
\003	ETX	End of Text
\006	ACK	Acknowledge
\025	NACK	Negative Acknowledge

Some camera manufacturers offer Windows utilities to send configuration strings to their cameras. Using such a utility, you can configure the camera on Windows and save the settings on the camera. You can then connect the camera to the target computer and use it.

Other camera manufacturers require a special serial cable that connects the serial communication line of the camera to a separate serial connection. In this case, you cannot initialize the camera using settings in the **Camera configuration serial command** section. Instead, you connect the DB9 to a serial port on the development computer and use manufacturer software to configure the camera before use.

Install BitFlow Neon-CLB Support

To add support for BitFlow Neon-CLB I/O modules, do the following:

- 1** From the BitFlow web site (www.bitflow.com), install the BitFlow SDK.
- 2** After installing the BitFlow SDK, test the installation by building and downloading a video example.

Video Blocks

BitFlow Neon-CLB

Support for BitFlow Neon-CLB camera interface board

Board

BitFlow Neon-CLB

General Description

The BitFlow Neon-CLB board has:

- One camera port that supports one camera that is compliant with Camera Link with power over Camera Link (PoCL)
- SafePower, which protects against Camera Link power line faults

The BitFlow Neon-CLB board requires a PCI Express x4 or wider slot. The Simulink Real-Time block library supports this board with the NEON BitFlow Image Input block.

Board Characteristics

Board name	BitFlow Neon-CLB
Manufacturer	BitFlow
Bus type	PCI Express
Multiple block instance support	No
Multiple board support	No

Related Examples

- “Install BitFlow Neon-CLB Support” on page 25-15

More About

- “Camera Link Camera Triggering” on page 25-9

- “Serial Camera Configuration” on page 25-13

External Websites

- www.bitflow.com

NEON BitFlow Image Input

Support for NEON BitFlow Image Input block

Library

Simulink Real-Time Library for BitFlow Camera Link

Description

Use the **NEON BitFlow Image Input** block to acquire real-time video frames or still images from a Camera Link camera. Attach the camera to a BitFlow Neon-CLB camera interface board on the target computer. After you acquire the image, you can:

- Display the output on the target computer monitor using a **Video Display** block.
- Stream captured frames to the development computer display (for example, using the **To Video Display** block from Computer Vision System Toolbox).
- Analyze the image signals on the development computer.
- Compress or decompress the input signal with the **JPEG Compression** or **JPEG Decompression** blocks.

The **Image signal** type for the **NEON BitFlow Image Input** block output is Single multidimensional signal.

Block Parameters

Camera config file

Click the **Browse** button to select a configuration from the BitFlow SDK installation folder.

The browser window displays a list of camera configuration files for BitFlow R64-type camera boards. The **BitFlow Neon CLB** board supports cameras from this list. Scroll and open the camera configuration file specified by you and your BitFlow representative—for example, `CIS-VCC-G21V31CL-E1-FreeRun.r64`. Alternatively, start typing the manufacturer name, and an abbreviated list of camera configuration

files appears for that manufacturer. Open the BitFlow camera configuration file for your camera model.

If you cannot locate your camera in the list, contact BitFlow to find a camera that is compatible with your requirements.

When you open the configuration file, it assigns values to the noneditable parameters:

Manufacturer

Displays camera manufacturer name.

Model

Displays the model of the camera that the configuration file configures and works with.

Mode

Describes the camera operation mode.

Bit Depth

Displays the number of bits per pixel that the camera uses.

Acquisition Timeout

Displays the number of milliseconds before the board sends an interrupt. For example, if the camera is not on, the board emits an interrupt.

Full Width

Displays the width of the incoming image, in pixels.

Full Height

Displays the height of the incoming image, in lines.

Trigger Mode

From the Trigger Mode list, select one of the following:

- **Free Running.** The camera and frame grabber run continuously. When the camera finishes an exposure, the frame grabber board copies the image to target memory using DMA and signals a frame completion interrupt. Upon receiving the interrupt, the model runs and performs image processing.
- **Timer Triggered.** The target computer system timer starts the model. When the model runs, it simultaneously starts a camera exposure and begins to process the image captured during the previous time step. When the camera finishes the

exposure, the frame grabber copies the image to target memory using DMA for processing in the next time step.

- **Differential Trigger.** A rising edge on the differential trigger input triggers the camera. When the camera finishes the exposure, the frame grabber copies the image to target memory using DMA and signals a frame completion interrupt. Upon receiving the interrupt, the model runs and performs image processing.
- **TTL Trigger.** A rising edge on the TTL trigger input triggers the camera. The model runs from the frame completion interrupt, as with **Differential Trigger**.
- **Opto Trigger.** A rising edge on the Opto trigger input triggers the camera. The model runs from the frame completion interrupt, as with **Differential Trigger**.

The camera configuration file determines whether you can use the block mask to switch the trigger mode to another mode, such as **Free Running**. You may need to contact BitFlow for a camera configuration file for the mode that you want.

Acquisition Region of Interest

Select a rectangular region of the full image to output from the block. When you select a new camera configuration file, these values are set to the full size of the image specified in the configuration file.

Column 0, row 0 is in the upper left corner of the image.

Starting Column

Column numbers are 0-based.

Starting Row

Row numbers are 0-based.

Columns

The number of columns plus the starting column must be less than the full image width.

Rows

The number of rows plus the starting row must be less than the full image height.

Camera configuration serial command

Select the serial port configuration and specify a command to send to the camera when the model starts executing.

Baud Rate

Select one of the following: 9600, 19200, 38400, 57600, 115200, 230400, or 460800 baud.

Bits per Byte

Select one of the following: 5, 6, 7, or 8. Most camera configurations use 8 bits per byte.

Parity

Select one of the following: None, Even, Odd, Mark, or Space.

Stop Bits

Select either 1 or 2.

Command String

Enter a command string to send to your camera. The exact format of the string depends on the camera.

Display camera response string

Select this check box to display the camera response to the command string. Nonprintable control codes are printed as C escape sequences.

Camera Configuration comments

Displays comments from BitFlow, Inc., about this configuration.

Sample time

Enter a base sample time or a multiple of the base sample time.

If you configure the real-time application to use the board interrupt, the application adds the sample time to the displayed execution time.

PCI slot (-1:autosearch)

If only one board of this type is in the target computer, enter -1 to locate the board.

If two or more boards of this type are in the target computer, enter the bus number and the PCI slot number of the board associated with this driver block. Use the format **[BusNumber,SlotNumber]**.

To determine the bus number and the PCI slot number, type:

```
tg = slrt;  
getPCIInfo(tg, 'installed')
```

Related Examples

- “Install BitFlow Neon-CLB Support” on page 25-15

More About

- “Camera Link Camera Triggering” on page 25-9
- “Serial Camera Configuration” on page 25-13

External Websites

- www.bitflow.com

From USB Video Device

From USB Video Device block

Library

Simulink Real-Time Library for USB Camera

Description

The `From USB Video Device` block enables you to acquire real-time video frames or still images from a USB Video Class (UVC) webcam. You attach the webcam to a USB port on the target computer. After you acquire the image, you can:

- Display the output on the target computer monitor using a `Video Display` block.
- Stream captured frames to the development computer display (for example, using the `To Video Display` block from Computer Vision System Toolbox).
- Analyze the image signals on the development computer.
- Compress or decompress the input signal with the `JPEG Compression` or `JPEG Decompression` blocks.

When you add this block, also add the `USB Video Device List` block to help configure the webcam.

The **Image signal** setting determines the **Image signal** setting for blocks receiving this signal, such as the `Video Display` block.

Note: When executed on a single-core target computer, the `From USB Video Device` block can drop frames if insufficient time is available to process frames received through the USB port. If the block is dropping frames, select a larger frame interval, lengthen the sample time, or use a multicore target computer.

Block Parameters

Configuration

Select a configuration that you specified in the **USB Video Device List** block. When you click the **Reload Device List** button on the **USB Video Device List** block, this configuration list is updated.

Port address (-1 for any)

Specify the port to which the webcam is attached. Enter -1 for any USB port.

Image width

Enter the width of the image input from the USB port, in pixels.

Image height

Enter the height of the image input from the USB port, in pixels.

Frame interval

Select the sample time between frame transfers:

- 1/60
- 1/30
- 1/25
- 1/20
- 1/15
- 1/10
- 1/7.5
- 1/5

Frame format

Select whether the incoming frames are to be compressed:

- Uncompressed

Do not compress frames.

- MJPEG

Compress frames using Motion JPEG format. Each frame is individually compressed as a JPEG image. Selecting this option disables the **Color format** and **Image signal** parameters.

Color format

Select the color format for the incoming frames:

- **RGB24 (8:8:8)**

Output frames using RGB24 color encoding.

- **YCbCr (4:2:2)**

Output frames using YCbCr color encoding.

Image signal

- **One multidimensional signal**

One signal where each dimension contains color information. Selecting this option creates one port, Image.

- **Separate color signals**

Multiple color signals where each signal contains the information for one color. Selecting this option creates the following ports, depending upon the colorspace.

- **RGB:** ports R, G, B
- **YCbCr:** ports Y, Cb, Cr

Show trigger input

Select this check box to display an input port, Trigger, for the block.

Show length output

Select this check box to display an output port, Length, for the block.

More About

- “Serial Camera Configuration” on page 25-13

Image Receive

Image Receive block

Library

Simulink Real-Time Library for Video Utilities

Description

The Image Receive block receives the video from the target computer at the IP address and port pair.

Block Outputs

Name	Description
Data	Vector of byte containing video data received by block.
Status	1 if the block received a full fixed-length frame, and otherwise 0. Visible when the Allow variable length packets check box is cleared (default).
Length	Number of bytes received. Visible when the Allow variable length packets check box is set.

Block Parameters

IP address to receive from (0.0.0.0 for accepting all)

Enter a valid IP address as a dotted decimal string for the source address, for example, 10.10.10.3. You can also use a MATLAB expression that returns a valid IP address as a string.

The default address, 0.0.0.0, enables the acceptance of frames from any accessible target computer. If set to a specific IP address, packets arriving from only that IP address are received.

The **IP port to receive from** parameter specifies the port for the source.

IP port to receive from

Specify the port of the target computer from which to receive the video frames. The **IP address to receive from (0.0.0.0 for accepting all)** parameter specifies the IP address for the source.

Use the following local IP port (-1 for automatic port assignment)

Specify the port of the target computer receiving the video frames.

Enter -1 to automatically assign a port for the target computer.

Allow variable length packets

Select this check box to enable the reception of variable-length frames. For example, use this option for compressed frames, because the length of each frame varies.

Selecting this block changes the default Status output port to the Length output port.

Sample time

Enter the base sample time or a multiple of the base sample time (-1 means sample time is inherited).

See Also

Image Transmit

More About

- “Serial Camera Configuration” on page 25-13

Image Transmit

Image Transmit block

Library

Simulink Real-Time Library for Video Utilities

Block Inputs

Name	Description
Data	Vector of byte containing video data for the block to transmit.
Length	Number of bytes to transmit. Visible when the Allow variable length packets check box is set.

Description

The Image Transmit block sends the video frame from the target computer to the development computer at the IP address and port pair.

Block Parameters

IP address sent to (255.255.255.255 for broadcast)

Specify the IP address of the target computer to which you send the video frames. To broadcast the video frames to all listening computers, enter 255.255.255.255. The **Remote IP port to send to** parameter specifies the port for the destination.

Remote IP port to send to

Specify the target computer port to which you send the video frames. The **IP address sent to (255.255.255.255 for broadcast)** parameter specifies the IP address for the destination.

Use the following local IP port (-1 for automatic port assignment)

Specify the target computer port from which to send the video frames.

Enter -1 to automatically assign a port for the target computer.

Allow variable length packets

Select this check box to enable the transmission of variable-length frames. For example, use this option for compressed frames, because the length of each frame varies.

If this check box is selected, the Data port sends the actual data. The Length input port becomes visible and contains the number of bytes being sent. If the port size is less than Length, the block sends up to the port size.

If this check box is cleared (default), the block sends only fixed-length packets.

Sample time

Enter the base sample time or a multiple of the base sample time (-1 means sample time is inherited).

See Also

Image Receive

More About

- “Serial Camera Configuration” on page 25-13

JPEG Compression

JPEG Compression block

Library

Simulink Real-Time Library for Video Utilities

Description

The JPEG Compression block compresses the video frame received by the target computer.

Block Inputs and Outputs

Inputs

Name	Description
Image	Video frame to compress

Outputs

Name	Description
Data	Vector of byte containing video data compressed by block.
Length	Number of bytes of compressed data. Visible when the Show output image length check box is set.

Block Parameters

Compression quality (-1:default)

Enter a value between 0 and 100 to specify how much to compress the incoming video frame. The lower the value, the less the compression quality.

Enter -1 to use the default compression quality for the video frame.

Input colorspace

One of the following:

- Grayscale

Compress the video frame using a grayscale color space scheme.

- YCbCr 4;4:4

Compress the video frame using the YCbCr color space scheme.

- RGB

Compress the video frame using the red, blue, green (RGB) color space scheme.

Image signal

- One multidimensional signal

One signal where each dimension contains color information. Selecting this option creates one port, Image.

- Separate color signals

Multiple color signals where each signal contains the information for one color. Selecting this option creates the following ports, depending upon the colorspace.

- Grayscale: port Image
- RGB: ports R, G, B
- YCbCr: ports Y, Cb, Cr

Max output image size (bytes)

Enter the maximum output size for the compressed video frame, in bytes. Use format *height * width*.

Show output image length

Select this check box to output the video frame length. Selecting this check box displays the Length port.

See Also

JPEG Decompression

JPEG Decompression

JPEG Decompression block

Library

Simulink Real-Time Library for Video Utilities

Description

The JPEG Decompression block decompresses the video frame received by the target computer.

Block Inputs and Outputs

Inputs

Name	Description
Data	Vector of <code>byte</code> containing video data for the block to decompress.
Trigger	Trigger for video decompression, active high. Visible when the Show trigger input check box is set.

Outputs

Name	Description
Image	Decompressed video frame

Block Parameters

Image width

Specify the width, in bytes, of the video frame to be decompressed.

Image height

Specify the height, in bytes, of the video frame to be decompressed.

Output colorspace

One of the following:

- Grayscale

Compress the video frame using a grayscale color space scheme.

- YCbCr 4;4:4

Compress the video frame using the YCbCr color space scheme.

- RGB

Compress the video frame using the red, blue, green (RGB) color space scheme.

Image signal

- One multidimensional signal

One signal where each dimension contains color information. Selecting this option creates one port, Image.

- Separate color signals

Multiple color signals where each signal contains the information for one color. Selecting this option creates the following ports, depending upon the colorspace.

- Grayscale: port Image
- RGB: ports R, G, B
- YCbCr: ports Y, Cb, Cr

Show trigger input

Select this check box to display an input port, Trigger, for the block.

See Also

JPEG Compression

USB Video Device List

USB Video Device List block

Library

Simulink Real-Time Library for USB Camera

Description

When you connect a USB Video Class (UVC) webcam to the target computer, the `USB Video Device List` block probes the device and displays the manufacturer information of the webcam. Based on this information, the block configures its parameters with supported options. You can choose the configuration parameters required by your USB webcam, and then name the configuration for future use.

When you add the `From USB Video Device` block to your model, add the `USB Video Device List` block. You need the `USB Video Device List` block to configure the webcam.

Block Parameters

Manufacturer

Select the manufacturer for the installed webcam.

Format

Select an image format that the connected webcam supports, for example, MJPEG.

Resolution

Select a supported resolution for the image.

Interval

Select the sample time for the video frame.

Configurations

Use this parameter to store and name a particular configuration. A configuration consists of the settings that you select for a particular webcam.

After you select the options in the other parameters:

- 1** In the edit field, enter a name for the configuration.
- 2** Click the **Add** button to add the configuration.

To remove the configuration, click the **Remove** button.

Reload Device List

Click this button to refresh the list of webcam information. Clicking this button also updates the mask and parameters for the From USB Video Device block.

See Also

Image Receive

More About

- “Serial Camera Configuration” on page 25-13

Video Display

Video Display block

Library

Simulink Real-Time Library for Video Utilities

Description

When you add the **Video Display** block to your model, you can display an RGB video signal on the target computer. The signal can come from a USB Video webcam, a Camera Link camera, or even a constant block.

The **Image signal** setting must match the **Image signal** setting for the camera output block.

There can be no more than two **Video Display** blocks in a model. The combined number of **Video Display** blocks and target scopes cannot exceed nine.

Block Parameters

Image signal

- **One multidimensional signal**

One signal where each dimension contains color information. Selecting this option creates one port.

- **Separate color signals**

Multiple color signals where each signal contains the information for one color. Selecting this option creates three ports.

Image colorspace

Can only be RGB.

See Also

“Target Scope Usage”

XCP Master Mode

XCP Master Mode

The Universal Measurement and Calibration Protocol (XCP) is a network protocol that you can use to connect calibration systems to electronic control units (ECUs).

A node in the network can run in either master mode or slave mode. Simulink Real-Time supports using XCP in master mode to replace (bypass) a subsystem of the ECU controller. The bypass model applies stimulus to the subsystem output signals and acquires signal response from the ECU controller.

To support XCP master mode, the Simulink Real-Time software provides the XCP sublibrary. You can:

- Parse A2L (ASAP2 database) files.
- Synchronize one or more slave or ECU devices.
- Initialize an XCP slave server running in an ECU.
- Apply stimulus data.
- Acquire real-time measurement data when specific events occur.

To create models to run in master mode:

- Provide an A2L (ASAP2) format file that contains signal and parameter access information for the slave ECUs and for the XCP-specific network elements.
- Provide an XCP Configuration block to load the A2L data into the XCP database.
- Provide one XCP CAN Transport Layer or XCP UDP Transport Layer block for each XCP Configuration block.

Simulink Real-Time supports XCP implemented by using FIFO mode CAN or real-time UDP as transport protocols.

- Apply stimulus data to the slave device by using the XCP Data Stimulation block.
- Acquire measurement data from the slave device by using the XCP Data Acquisition block.

See Also

XCP CAN Transport Layer | XCP Configuration | XCP Data Acquisition | XCP Data Stimulation | XCP UDP Transport Layer

More About

- “CAN”
- “FIFO Mode” on page 6-2
- “Real-Time UDP”
- “Third-Party Calibration Support”

XCP Blocks

XCP CAN Transport Layer
XCP Configuration
XCP Data Acquisition
XCP Data Stimulation
XCP UDP Transport Layer

XCP CAN Transport Layer

Generate and consume XCP messages that are transported by CAN hardware

Library

Simulink Real-Time Library for XCP

Block Inputs and Outputs

Inputs

Name	Description
CAN Msg	Vector of CAN MESSAGE structures being consumed
N	Number of messages in the vector

Outputs

Name	Description
CAN Msg	Vector of CAN MESSAGE structures being generated
N	Number of messages in the vector

Description

The XCP CAN Transport Layer block handles CAN messages that are transmitted or received by the CAN blocks in the Simulink Real-Time Library.

Connect the input side of the block to a block that receives CAN messages. Connect the output side of the block to a block that transmits the XCP messages over CAN. You must set up the transmitting block so that a CAN message is sent only when an XCP message is available. Otherwise, the block sends 0 byte data when XCP messages are not available, causing undefined behavior.

See Also

XCP Data Acquisition | XCP Configuration | XCP Data Stimulation

External Websites

- www.asam.net

XCP Configuration

Configure XCP slave connection

Library

XCP Communication

Description



The XCP Configuration block uses the parameters specified in the A2L file and the ASAP2 database to establish XCP slave connection.

Specify the A2L file to use in your **XCP Configuration** before you acquire or stimulate data. Use one **XCP Configuration** to configure one slave for data acquisition or stimulation. If you add Data Acquisition and Data Stimulation blocks, your model checks to see if there is a corresponding **XCP Configuration** block and will prompt you to add one.

Other Supported Features

The XCP communication blocks support the use of Simulink Accelerator and Rapid Accelerator mode. Using this feature, you can speed up the execution of Simulink models. For more information on this feature, see the Simulink documentation.

The XCP communication blocks also support code generation with limited deployment capabilities. Code generation requires the Microsoft C++ compiler.

Dialog Box

Use the Block Parameters dialog box to select your XCP configuration.

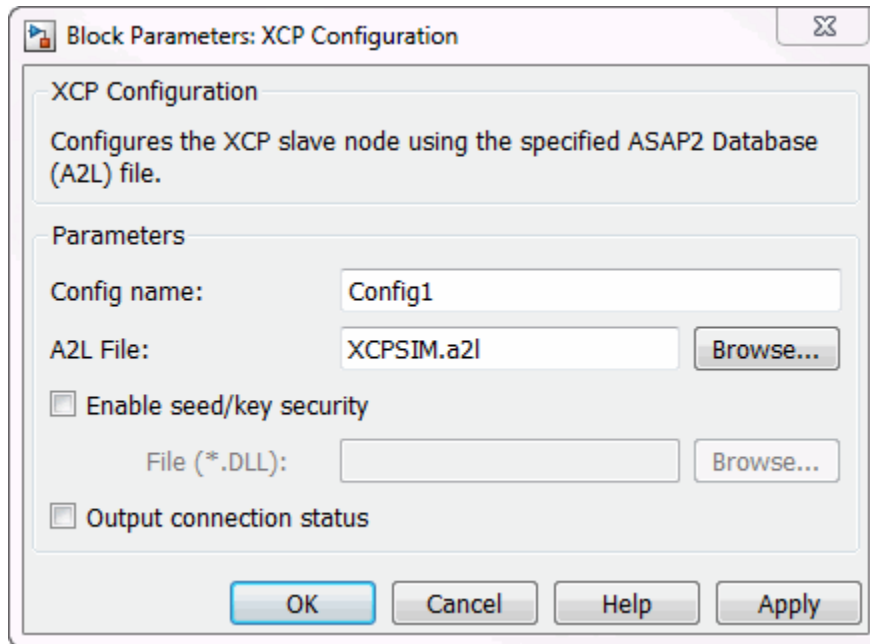

Config name

Specify a unique name for your XCP session.

A2L File

Click **Browse** to select an A2L file for your XCP session.

Enable seed/key security

Select this option if your slave requires a secure key to establish connection. You need to select a file that contains the seed/key definition to enable the security.

File (*.DLL)

This field is enabled if you select **Enable seed/key security**. Click **Browse** to select the file that contains seed and key security algorithm used to unlock an XCP slave module.

Output connection status

Select this option to display the status of the connection to the slave module. Selecting this option adds a new output port.

Introduced in R2013a

XCP Data Acquisition

Acquire selected measurements from configured slave

Library

XCP Communication

Description

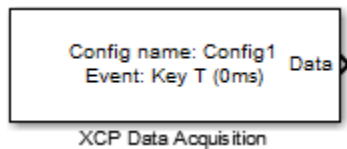

The XCP Data Acquisition block acquires data from the configured slave based on the selected measurements. The block uses the XCP CAN transport layer to obtain raw data for the selected measurements at the specified simulation time step. Configure your XCP connection and use the XCP Data Acquisition block to select your event and measurements for the configured slave. The block displays the selected measurements as output ports.

Note A model with XCP Data Acquisition blocks does not disconnect from the XCP slave when the simulation ends. The model continues to acquire measurements until the data transmission from the XCP slave is terminated.

Other Supported Features

The XCP communication blocks support the use of Simulink Accelerator and Rapid Accelerator mode. Using this feature, you can speed up the execution of Simulink models. For more information on this feature, see the Simulink documentation.

The XCP communication blocks also support code generation with limited deployment capabilities. Code generation requires the Microsoft C++ compiler.

Dialog Box

Use the Block Parameters dialog box to select your data acquisition parameters.

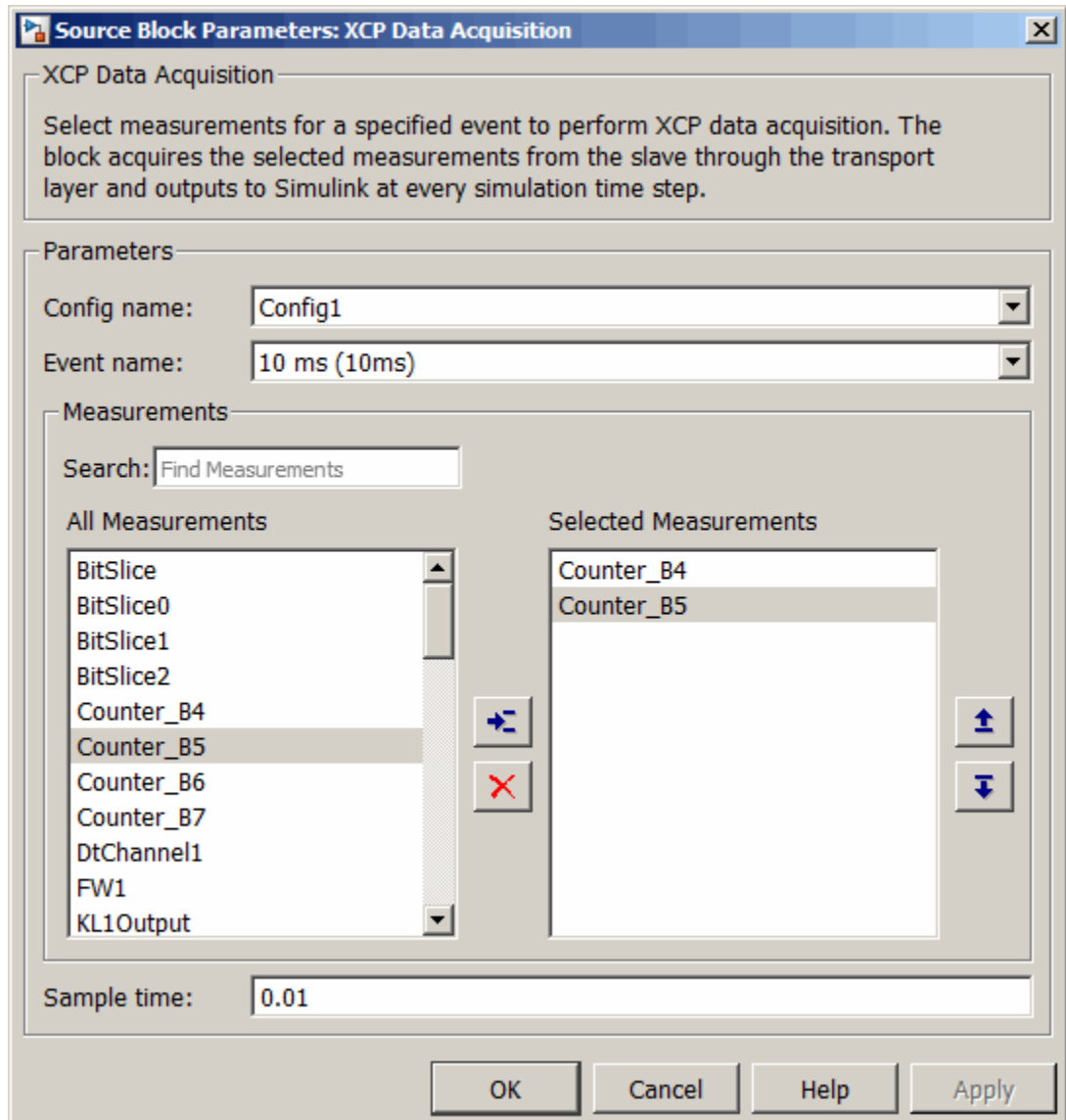

Parameters

Config name

Select the name of XCP configuration you want to use. The list displays all available names specified in the available XCP Configuration blocks in the model. Selecting a configuration displays events and measurements available in this configuration's A2L file.

Note: You can acquire measurements for only one event using an XCP Data Acquisition block. Use one block each for each event whose measurements you want to acquire.

Event name

Select an event from the available list of events. The XCP Configuration block uses the specified A2L file to populate the events list.

Measurements

Search

Type the name of the measurement you want to use. The All Measurements lists displays a list of all matching terms. Click the x



to clear your search.

All Measurements

This list displays all measurements available for the selected event. Select the



measurement you want to use and click the add button,  to add it to the selected measurements. Hold the **Ctrl** key on your keyboard to select multiple measurements.

Selected Measurements

This list displays selected measurements. To remove a measurement from this list, select the measurement and click the remove button, .

Toggle buttons



Use the toggle buttons   to reorder the selected measurements.

Sample time

Specify the sampling time of the block during simulation, which is the simulation time as described by the Simulink documentation. This value defines the frequency at which the XCP Data Acquisition block runs during simulation. If the block is inside a triggered subsystem or to inherit sample time, you can specify `-1` as your sample time. You can also specify a MATLAB variable for sample time. The default value is 0.01 (in seconds).

See Also

XCP Configuration

Introduced in R2013a

XCP Data Stimulation

Perform data stimulation on selected measurements

Library

XCP Communication

Description

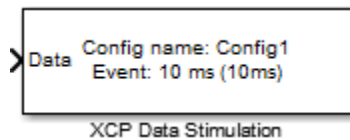

The XCP Data Stimulation block sends data to the selected slave for the selected event measurements. The block uses the XCP CAN transport layer to output raw data for the selected measurements at the specified stimulation time step. Configure your XCP session and use the XCP Data Stimulation block to select your event and measurements on the configured slave. The block displays the selected measurements as input ports.

Other Supported Features

The XCP communication blocks support the use of Simulink Accelerator and Rapid Accelerator mode. Using this feature, you can speed up the execution of Simulink models. For more information on this feature, see the Simulink documentation.

The XCP communication blocks also support code generation with limited deployment capabilities. Code generation requires the Microsoft C++ compiler.

Dialog Box

Use the Block Parameters dialog box to select your data stimulation parameters.

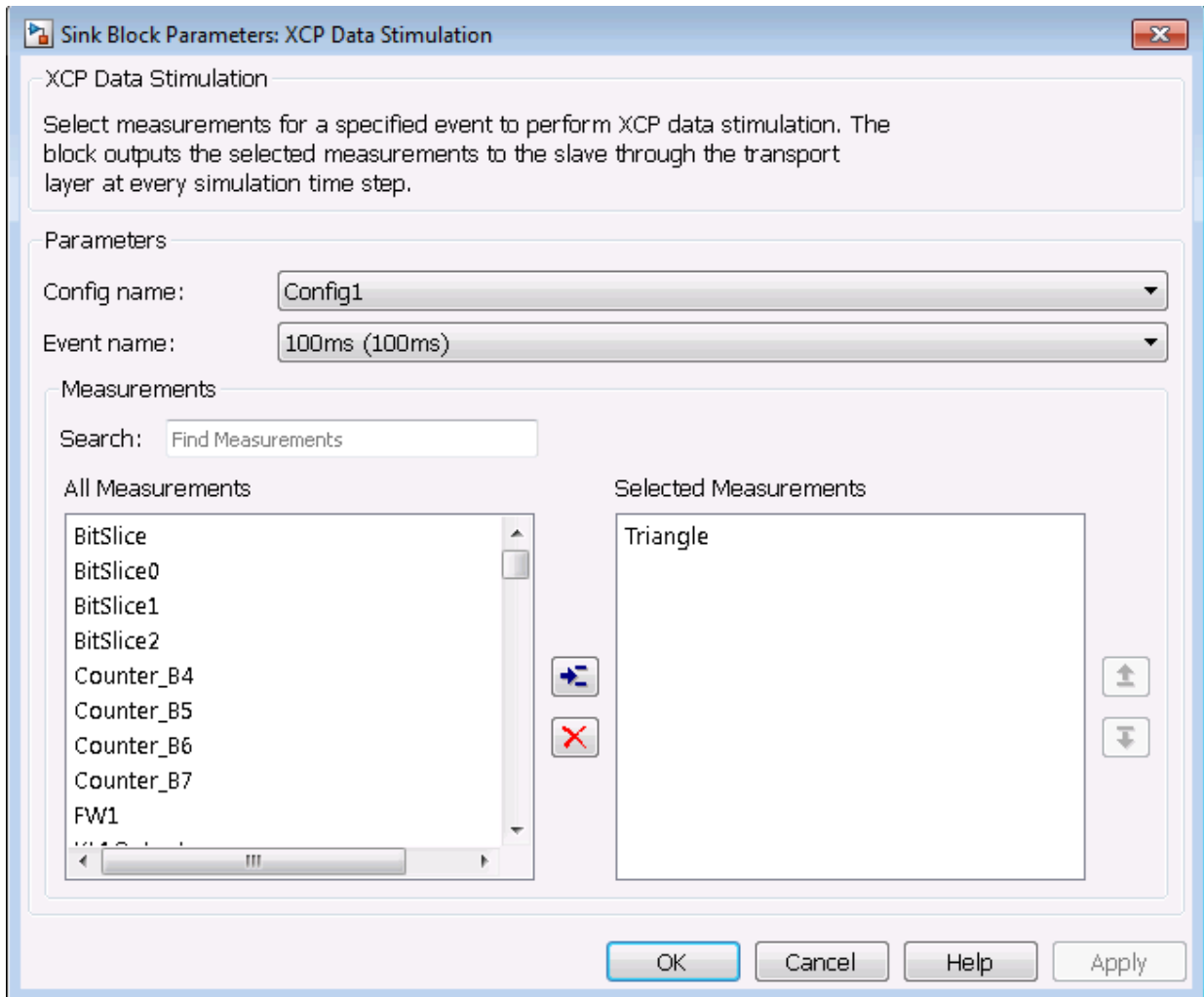

Parameters

Config name

Select the name of XCP configuration you want to use. The list displays all available names specified in the available XCP Configuration blocks in the model. Selecting

a configuration displays events and measurements available in this configuration's A2L file.

Note: You can stimulate measurements for only one event using an XCP Data Stimulation block. Use one block each for each event whose measurements you want to stimulate.

Event name

Select an event from the available list of events. The XCP Configuration block uses the specified A2L file to populate the events list.

Measurements

Search

Type the name of the measurement you want to use. The All Measurements lists displays a list of all matching terms. Click the x



to clear your search.

All Measurements

This list displays all measurements available for the selected event. Select the

measurement you want to use and click the add button,  to move it to the selected measurements. Hold the **Ctrl** key on your keyboard to select multiple measurements.

Selected Measurements

This list displays selected measurements. To remove a measurement from this list,

select the measurement and click the remove button, .

Toggle buttons

Use the toggle buttons   to reorder the selected measurements.

Introduced in R2013a

XCP UDP Transport Layer

Send and receive XCP messages over real-time UDP

Library

Simulink Real-Time Library for XCP

Description

The XCP UDP Transport Layer block uses the specified Ethernet device to send and receive XCP messages. Select the Ethernet device using the PCI bus and slot numbers.

Block Parameters

Master IP Address

Enter the IP address for the UDP master node.

Simulink Real-Time supports modeling the UDP master node only.

Port

UDP port that the transport layer uses.

Subnet mask

Enter the subnet mask for the interface.

Gateway

Enter the gateway address for the interface.

Ethernet Driver

Identifies the Ethernet driver for each chip family supported. Possible values are Intel 8255X and Intel Gigabit.

PCI bus

Enter the PCI bus number for the Ethernet card.

PCI slot

Enter the PCI slot number for the Ethernet card.

Disable CTR error detection

Select this check box to turn off bus controller error detection.

Sample time

Enter the base sample time or a multiple of the base sample time (- 1 means sample time is inherited).

See Also

XCP Data Acquisition | XCP Configuration | XCP Data Stimulation

External Websites

- www.asam.net

Adlink

Adlink PCI-6208

Support for the Adlink PCI-6208 digital-to-analog converter board

Board

Adlink PCI-6208

General Description

The Adlink PCI-6208A is a digital to analog converter board. This board has four bits of digital input and four bits of digital output lines.

The Simulink Real-Time block library supports this board with the following driver blocks:

- Adlink PCI-6208A Analog Output
- Adlink PCI-6208A Digital Input
- Adlink PCI-6208A Digital Output

Board Characteristics

Board name	PCI-6208A
Manufacturer	Adlink
Bus type	PCI
Access method	I/O mapped
Multiple block instance support	No
Multiple board support	Yes

External Websites

- www.adlinktech.com

Adlink PCI-6208A Analog Output

Adlink PCI-6208A Analog Output block

Library

Simulink Real-Time Library for Adlink

Scaling Output to Input

I/O Module Output	Block Input Data Type	Scaling
ma	Double	1

Block Parameters

Channel vector

Enter a vector of numbers to specify the output channels.

For example, to use the first and second analog output (D/A) channels enter

[1, 2]

The channel numbers can occur in arbitrary order. Number the channels beginning with 1 even if this board manufacturer numbers them beginning with 0. The maximum allowable channel number is 4.

Range

From the list, choose

- 0 to 20 ma
- 5 to 25 ma
- 4 to 20 ma

Signal input to the block is in milliamperes (mA). The output voltage maximum is 10 volts. If the resistance is too large to get the chosen current, the voltage measured across the output load will saturate.

For example, assume an input sine wave with:

$$\text{Input} = 10 \cdot \sin(\omega \cdot t) + 10$$

If you set the range to **0 to 20 ma**, the current should oscillate from 0 to 20 ma at ω radians per second. The current will only reach 20 ma if the load resistance is less than or equal to 500 ohms. If the load resistance is 1000 ohms, the maximum current that 10 volts can drive is only 10 ma. The top half of the sine wave will be clipped off.

Note the following:

- This block is scaled for the current output ports, not the voltage output ports.
- This block limits output to positive values only. This is in response to the manufacturer documentation, which cautions that driving a negative voltage from the D/A converter to the voltage to current output board might cause damage to the current output.

Reset vector

The reset vector controls the behavior of the channel at model termination. Enter a scalar or a vector that is the same length as the channel vector. If you specify a scalar value, that setting is replicated over the channel vector. If you specify a value of 1, the corresponding channel is reset to the value specified in the initial value vector. If you specify a value of 0, the channel remains at the last value attained while the model was running. For example, if **Channel vector** is [1 2] and the **Reset vector** is [1], the action taken will be the same as if Reset vector was set to [1 1]. Both channels will be reset to their initial values when model execution is stopped.

Initial value vector

The initial value vector contains the initial current values for the output channels. Enter a scalar or a vector that is the same length as the channel vector. If you specify a scalar value, that value is replicated as initial value over the channel vector. The channels are set to the initial values between the time the model is downloaded and the time it is started. When model execution is stopped, the corresponding position in **Reset vector** is checked. Depending on that value, the channel is either reset to the initial value or remains at the last value attained while the model was running. For example, assume that **Channel vector** is [1 2], **Reset vector** is [1 0], and **Initial value vector** is [2.3 5.6]. On initial download, channel 1 is set to 2.3 ma and channel 2 to 5.6 ma. When the model is stopped, channel 1 resets to 2.3 ma and channel 2 remains at the last value attained.

Sample time

Enter the base sample time or a multiple of the base sample time (- 1 means sample time is inherited).

External Websites

- www.adlinktech.com

Adlink PCI-6208A Digital Input

Adlink PCI-6208A Digital Input

Library

Simulink Real-Time Library for Adlink

Scaling Input to Output

I/O Module Input	Block Output Data Type	Scaling
TTL	Double	TTL low = 0 TTL high = 1

Block Parameters

Channel vector

Enter a vector of numbers to specify the digital input port ports.

For example, to use the first and second digital input channels enter

[1, 2]

The channel numbers can occur in arbitrary order. Number the channels beginning with 1 even if this board manufacturer numbers them beginning with 0. The maximum allowable channel number is 4. Each input can be listed at most once in this vector.

Sample time

Enter the base sample time or a multiple of the base sample time (-1 means sample time is inherited).

PCI slot

If only one board of this type is in the target computer, enter -1 to locate the board.

If two or more boards of this type are in the target computer, enter the bus number and the PCI slot number of the board associated with this driver block. Use the

format **[BusNumber,SlotNumber]**. To determine the bus number and the PCI slot number, type:

```
tg = slrt;  
getPCIInfo(tg, 'installed')
```

External Websites

- www.adlinktech.com

Adlink PCI-6208A Digital Output

Adlink PCI-6208A Digital Output

Library

Simulink Real-Time Library for Adlink

Scaling Input to Output

I/O Module Output	Block Input Data Type	Scaling
TTL	Double	< 0.5 = TTL low > 0.5 = TTL high

Block Parameters

Channel vector

Enter a vector of numbers to specify the digital output channels.

For example, to use the first and second analog digital output channels enter

[1, 2]

The channel numbers can occur in arbitrary order. Number the channels beginning with 1 even if this board manufacturer numbers them beginning with 0. The maximum allowable channel number is 8.

Reset vector

The reset vector controls the behavior of the channel at model termination. Enter a scalar or a vector that is the same length as the channel vector. If you specify a scalar value, that setting is replicated over the channel vector. If you specify a value of 1, the corresponding channel is reset to the value specified in the initial value vector. If you specify a value of 0, the channel remains at the last value attained while the model was running. For example, if **Channel vector** is [1 2] and the **Reset vector** is [1], the action taken will be the same as if Reset vector was set to [1 1]. Both channels will be reset to their initial values when model execution is stopped.

Initial value vector

The initial value vector contains the initial voltage values for the digital output channels. Enter a scalar or a vector that is the same length as the channel vector. If you specify a scalar value, that value is replicated as initial value over the channel vector. The channels are set to the initial values between the time the model is downloaded and the time it is started. When model execution is stopped, the corresponding position in **Reset vector** is checked. Depending on that value, the channel is either reset to the initial value or remains at the last value attained while the model was running. For example, assume that **Channel vector** is [1 2], **Reset vector** is [1 0], and **Initial value vector** is [0 1]. On initial download, channel 1 is set to off and channel 2 to on. When the model is stopped, channel 1 resets to off and channel 2 remains at the last value attained.

If the **Initial value vector** value is greater than 0.5, the corresponding digital output port is turned on, otherwise it is turned off.

Sample time

Enter the base sample time or a multiple of the base sample time (- 1 means sample time is inherited).

PCI slot

If only one board of this type is in the target computer, enter - 1 to locate the board.

If two or more boards of this type are in the target computer, enter the bus number and the PCI slot number of the board associated with this driver block. Use the format [**BusNumber**, **SlotNumber**]. To determine the bus number and the PCI slot number, type:

```
tg = slrt;  
getPCIInfo(tg, 'installed')
```

External Websites

- www.adlinktech.com

BittWare

Running Models with BitWare Blocks

In this section...

“Model Notes” on page 30-2

“Frame Size, Sample Rate, and Sample Time Parameter Notes” on page 30-4

Model Notes

This topic describes notes on working with models that use the BitWare blocks.

- “Model Execution Timing” on page 30-2
- “Example Models” on page 30-3
- “Model Execution Limitations” on page 30-3

Model Execution Timing

To run the model, the Simulink Real-Time model is executed when each frame completes on the board. Set the simulation parameters to use the interrupt from the Audio-PMC+ rather than the timer interrupt when running the model. First, you need to determine the interrupt vector number to which the board is set. This is determined by the BIOS in the target computer when the target computer starts.

- 1 From the MATLAB Command Window, type

```
tg = slrt;  
getPCIInfo(tg, 'installed')
```

This command lists board information for the installed PCI devices that the Simulink Real-Time software knows about.

- 2 Find the IRQ specified for this board. This is the interrupt source number you need to specify in the **Real-time interrupt source** field of the **Simulink Real-Time Options** node.

Set the interrupt vector number:

- 1 From the MATLAB Command Window, type the name of your Simulink model.

The Simulink model appears

- 2 Click **Simulation > Model Configuration Parameters**.

The Configuration Parameter dialog box is displayed for the model.

- 3 Select the **Simulink Real-Time Options** node under the **Code Generation** node.
- 4 Set the **Execution mode** field to **Real-Time**.
- 5 Click the **Real-time interrupt source** list.
- 6 Select the interrupt source number to which the board is set.
- 7 Click the **I/O board generating the interrupt** list and select **AudioPMC+** from the list.
- 8 Click **OK** and save the model.

Failure to set the interrupt vector as described, which results in your using the Simulink Real-Time timer, will not stop the model from running. However, you will occasionally see corrupt data since the Audio-PMC+ clock and the Simulink Real-Time timer drift relative to each other and will sometimes overlap.

Example Models

Two example models are included with this version in the `xpcdemos` folder. To operate these, set the required interrupt source in the simulation parameters dialog.

`xpc8audiochannels` shows the use of all 8 input and 8 output channels at the same time. A block from DSP System Toolbox™ is used to convert from frame to sample based signals to drive the Simulink Real-Time scopes.

`xpcaudiospectrum` uses the Simulink Real-Time Spectrum Scope subsystem from the `xpcdpspectrum` sample model with the Audio-PMC+ as the source. This model requires that **Frame Size** be set to 1 because of the way the spectrum scope displays the results.

Model Execution Limitations

Model execution is entered each time a frame completes on the Audio-PMC+ board. The frame rate is the fastest clock available. You cannot obtain a minor step execution that runs more frequently than frame completions. To execute a multirate model, you must use the frame completion time as the fastest rate. The audio input and audio output blocks must be executed at the fastest rate in the model.

Input and output data from these blocks is in the form of a frame of data as used by DSP System Toolbox. If the frame size is 1, then the blocks revert to sample based signals. The blocks in DSP System Toolbox expect to see signals that are frames.

Frame Size, Sample Rate, and Sample Time Parameter Notes

Experimentally, with all 8 input and all 8 output channels in use, the Audio-PMC+ can run with sample rates below the following frequencies as a function of Frame Size:

Frame Size	Maximum Sample Rate
1	15 kHz
2	30 kHz
3	40 kHz
4	45 kHz
8	70 kHz
16	80 kHz
32	80 kHz
64	100 kHz
128	100 kHz
256	100 kHz

If fewer than 8 inputs and outputs are in use, then the maximum sample rate increases.

Frame Size	1 Channel	2 Channels	4 Channels	6 Channels	8 Channels
1	30 kHz	30 kHz	25 kHz	18 kHz	15 kHz
2	60 kHz	60 kHz	45 kHz	33 kHz	30 kHz

These rates were obtained from testing at MathWorks. As with all benchmarks, results depend upon a number of conditions, such as:

- PCI bus interface chip set on the target computer motherboard
- Main memory speed
- General motherboard architecture

BVM, Contec, Curtiss-Wright

BVM

This topic describes the BVM I/O board supported by the Simulink Real-Time product (www.bvmltd.co.uk).

BVM PMCDIO64

BVM PMCDIO64 Digital Input

BVM PMCDIO64 Digital Output

BVM PMCDIO64

Support for 64-bit digital I/O

Board

BVM PMCDIO64

General Description

The PMCDIO64 is a 64-bit digital I/O board. The board provides 64 bits, which the driver splits into two ports of 32 bits each. Each port can be configured to be either input or output. In addition, each port can be configured to be either 32 independent 1-bit channels or a single 32-bit wide integer channel.

The Simulink Real-Time block library supports this board with these driver blocks:

- BVM PMCDIO64 Digital Input
- BVM PMCDIO64 Digital Output

Board Characteristics

Board name	PMCDIO64
Manufacturer	BVM
Bus type	PCI
Access method	Memory mapped
Multiple block instance support	Yes
Multiple board support	Yes

External Websites

- www.bvmltd.co.uk

BVM PMCDIO64 Digital Input

PMCDIO64 Digital Input block

Library

Simulink Real-Time Library for BVM

Scaling Input to Output

I/O Module Input	Block Output Data Type	Scaling
TTL	double	TTL low = 0.0 TTL high = 1.0

Block Parameters

Format

From the list, select either `32 One bit channels` or `Single 32 bit port`.

If the format is `32 One bit channels`, then the channel vector specifies the configuration of the block. Each output is a double with value of 0 or 1. The value is 0 when the input voltage is low.

If the format is `Single 32 bit port`, then the output from the block is a 32-bit integer, where the 32 bits on the I/O module feed into the single output. The channel vector is not used in this mode and is unavailable on the Block Parameters dialog box. The least significant bit is the lowest numbered bit in the manufacturer documentation.

Channel vector

This is a vector of channels. This parameter is only used when the format is `32 One bit channels`. Channels are numbered from 1 to 32 even if this manufacturer labels them 0 to 31.

Port

Each half of the 64 bits is a separate port. Port 1 is the lower 32 bits and Port 2 is the upper 32 bits. You can use one port for input and the other port for output.

Sample time

Enter the base sample time or a multiple of the base sample time (- 1 means sample time is inherited).

PCI slot (-1:autosearch)

If only one board of this type is in the target computer, enter - 1 to locate the board.

If two or more boards of this type are in the target computer, enter the bus number and the PCI slot number of the board associated with this driver block. Use the format [**BusNumber,SlotNumber**].

To determine the bus number and the PCI slot number, type:

```
tg = slrt;  
getPCIInfo(tg, 'installed')
```

External Websites

- www.bvmltd.co.uk

BVM PMCDIO64 Digital Output

PMCDIO64 Digital Output block

Library

Simulink Real-Time Library for BVM

Scaling Input to Output

I/O Module Output	Block Input Data Type	Scaling
TTL	double	$< 0.5 = \text{TTL low}$ $\geq 0.5 = \text{TTL high}$

Block Parameters

Format

From the list, choose either **32 One bit channels** or **Single 32 bit port**.

If the format is **32 One bit channels**, then the channel vector specifies the configuration of the block. Each input is a double. The output is set to low voltage if the input is < 0.5 and high voltage if the input is ≥ 0.5 .

If the format is **Single 32 bit port**, then the input to the block is a 32-bit integer where the 32 bits on the I/O module are controlled by the single input. The channel vector is not used in this mode and is unavailable on the Block Parameters dialog box. The least significant bit is the lowest numbered bit in the manufacturer documentation.

Channel vector

This is a vector of channels and is only used when the format is **32 One bit channels**. Channels are numbered from 1 to 32 even if this manufacturer labels them 0 to 31. I/O signal numbers IO32 to IO63 are acquired by choosing Port 2 and channels 1 to 32.

Reset action vector

If you chose **32 One bit channels**, enter a vector of 1's and 0's that is the same length as the channel vector. A value of 1 indicates that the channel is reset to the value in the initial value vector when the model is stopped. A value of 0 indicates that the output remains at the last value written when the model is stopped. If you enter a scalar value, that value is used for all channels.

If you chose **Single 32 bit port**, enter a 1 or a 0 to determine what happens when the model is stopped. If you enter 1, the 32 bits of the output are reset to the value given by the initial value vector. If you enter 0, the output remains at the last value written when the model is stopped.

Initial value vector

If you chose **32 One bit channels**, this vector determines both the initial value of the outputs at model download time and the values when model execution is stopped. A value of 1 for a given channel sets the output for that channel to 1 while any other value sets the output to 0.

If you chose **Single 32 bit port**, enter the scalar value to write to the output port. The value can be a hexadecimal or a decimal. If it is a hexadecimal, then use C syntax. For example, 0xaaaaaaaa in hexadecimal would be the equivalent of 2863311530 in decimal.

Port

Each half of the 64 bits is a separate port. Port 1 is the lower 32 bits and Port 2 is the upper 32 bits. You can use one port for input and the other port for output. In a given model, each port can only be set to one direction.

Sample time

Enter the base sample time or a multiple of the base sample time (- 1 means sample time is inherited).

PCI slot (-1:autosearch)

If only one board of this type is in the target computer, enter - 1 to locate the board.

If two or more boards of this type are in the target computer, enter the bus number and the PCI slot number of the board associated with this driver block. Use the format **[BusNumber,SlotNumber]**.

To determine the bus number and the PCI slot number, type:

```
tg = slrt;  
getPCIInfo(tg, 'installed')
```

External Websites

- www.bvmltd.co.uk

Contec

This topic describes the Contec I/O boards supported by the Simulink Real-Time product (www.contec.com).

Contec AD12-16(PCI)

Contec AD12-16(PCI) board

Board

Contec AD12-16(PCI)

General Description

The Contec AD12-16(PCI) is an I/O board with 16 single-ended or 8 differential analog input (A/D) channels (12 bit), 4 digital input lines, and 4 digital output lines.

The Simulink Real-Time block library supports this board with these driver blocks:

- Contec AD12-16(PCI) Analog Input (A/D)
- Contec AD12-16(PCI) Digital Input
- Contec AD12-16(PCI) Digital Output

The Simulink Real-Time software does not support the Counter/Timer functionality of the board.

Board Characteristics

Board name	AD12-16(PCI)
Manufacturer	Contec
Bus type	PCI
Access method	I/O mapped
Multiple block instance support	No
Multiple board support	Yes

External Websites

- www.contec.com

Contec AD12-16(PCI) Analog Input (A/D)

Contec AD12-16(PCI) Analog Input (A/D) block

Library

Simulink Real-Time Library for Contec

Scaling Input to Output

I/O Module Input	Block Output Data Type	Scaling
Volts	Double	1

Block Parameters

Channel vector

Enter a vector of numbers to specify the input channels. For example to use the first three analog input (A/D) channels, enter

```
[ 1, 2, 3]
```

The channel numbers can occur in arbitrary order. Number them beginning with 1 even if this board manufacturer numbers them beginning with 0.

The maximum allowable channel number for this board is 8 (differential-ended) or 16 (single-ended). If the highest channel number you specify is n , the I/O module converts all the channels between 1 and n , whether or not they occur in your channel vector. It is more efficient to specify a contiguous range of channels. (Permuting the order of such a range has little impact on efficiency however.)

Range vector

This board allows the range of each channel to be selected independently. Enter a scalar, in which case the same value is replicated over the channel vector, or a vector the same length as the channel vector.

The range vector entries must be range codes selected from the following table:

Input Range (V)	Range Code	Input Range (V)	Range Code
-10 to +10	-10	0 to 10	10
-5 to +5	-5	0 to 5	5
-2.5 to 2.5	-2	0 to 2.5	2
-1.25 to 1.25	-1	0 to 1.25	1

Polarity

Choose **single-ended** or **double-ended** (differential-ended). This setting is replicated over the channel vector.

Sample time

Enter the base sample time or a multiple of the base sample time (- 1 means sample time is inherited).

PCI slot (-1:autosearch)

If only one board of this type is in the target computer, enter - 1 to locate the board.

If two or more boards of this type are in the target computer, enter the bus number and the PCI slot number of the board associated with this driver block. Use the format **[BusNumber,SlotNumber]**.

To determine the bus number and the PCI slot number, type:

```
tg = slrt;
getPCIInfo(tg, 'installed')
```

External Websites

- www.contec.com

Contec AD12-16(PCI) Digital Input

Contec AD12-16(PCI) Digital Input block

Library

Simulink Real-Time Library for Contec

Scaling Input to Output

I/O Module Input	Block Output Data Type	Scaling
TTL	Double	TTL low = 0.0 TTL high = 1.0

Block Parameters

Channel vector

Enter a vector of numbers to specify the input channels. For example to use the first and third digital input channels enter

[1, 3]

The channel numbers can occur in arbitrary order. Number the channels beginning with 1 even if this board manufacturer numbers them beginning with 0. The maximum allowable channel number is 4.

Sample time

Enter the base sample time or a multiple of the base sample time (-1 means sample time is inherited).

PCI slot (-1:autosearch)

If only one board of this type is in the target computer, enter -1 to locate the board.

If two or more boards of this type are in the target computer, enter the bus number and the PCI slot number of the board associated with this driver block. Use the format [**BusNumber**, **SlotNumber**].

To determine the bus number and the PCI slot number, type:

```
tg = slrt;  
getPCIInfo(tg, 'installed')
```

External Websites

- www.contec.com

Contec AD12-16(PCI) Digital Output

Contec AD12-16(PCI) Digital Output block

Library

Simulink Real-Time Library for Contec

Scaling Input to Output

I/O Module Output	Block Input Data Type	Scaling
TTL	Double	< 0.5 = TTL low > 0.5 TTL high

Block Parameters

Channel vector

Enter a vector of numbers to specify the output channels. For example, to use the first and third digital output channels enter

[1, 3]

The channel numbers can occur in arbitrary order. Number the channels beginning with 1 even if this board manufacturer numbers them beginning with 0. The maximum allowable channel number is 4.

Reset vector

The reset vector controls the behavior of the channel at model termination. Enter a scalar or a vector that is the same length as the channel vector. If you specify a scalar value, that setting is replicated over the channel vector. If you specify a value of 1, the corresponding channel is reset to the value specified in the initial value vector. If you specify a value of 0, the channel remains at the last value attained while the model was running.

Initial value vector

The initial value vector contains the initial values (0 or 1) of the output channels. Enter a scalar or a vector that is the same length as the channel vector. If you enter a scalar, that value is replicated as the initial value over the channel vector. The channels are set to these initial values between the time the model is downloaded and the time it is started.

Sample time

Enter the base sample time or a multiple of the base sample time (- 1 means sample time is inherited).

PCI slot (-1:autosearch)

If only one board of this type is in the target computer, enter - 1 to locate the board.

If two or more boards of this type are in the target computer, enter the bus number and the PCI slot number of the board associated with this driver block. Use the format **[BusNumber,SlotNumber]**.

To determine the bus number and the PCI slot number, type:

```
tg = slrt;  
getPCIInfo(tg, 'installed')
```

External Websites

- www.contec.com

Contec AD12-16(PCI)E

Contec AD12-16(PCI)E board

Board

Contec AD12-16(PCI)E

General Description

The Contec AD12-16(PCI)E is an I/O board with 16 single-ended or 8 differential analog input (A/D) channels (12 bit), one analog output channel (12 bit), 4 digital input lines, 4 digital output lines, and an i8254-compatible counter.

The Simulink Real-Time block library supports this board with these driver blocks:

- Contec AD12-16(PCI)E Analog Input (A/D)
- Contec AD12-16(PCI)E Analog Output (D/A)

The Simulink Real-Time software does not support the digital I/O or Counter/Timer functionality of the board.

Board Characteristics

Board name	AD12-16(PCI)E
Manufacturer	Contec
Bus type	PCI
Access method	I/O mapped
Multiple block instance support	No
Multiple board support	Yes

External Websites

- www.contec.com

Contec AD12-16(PCI)E Analog Input (A/D)

Contec AD12-16(PCI)E Analog Input block

Library

Simulink Real-Time Library for Contec

Scaling Input to Output

I/O Module Input	Block Output Data Type	Scaling
Volts	Double	1

Block Parameters

Channel vector

Enter a vector of numbers to specify the input channels. For example, to use the first three analog input (A/D) channels, enter

```
[1, 2, 3]
```

The channel numbers can occur in arbitrary order. Number them beginning with 1 even if this board manufacturer numbers them beginning with 0. The maximum allowable channel number for this board is 8 (differential-ended) or 16 (single-ended).

Gain vector

To specify the gain, enter 1, 2, 4, or 8 for each of the channels in the channel vector. The gain vector must be the same length as the channel vector. If you enter a scalar, the value is replicated over the channel vector.

The gain is applied to the signal prior to sampling the voltage. After the signal voltage is sampled, the result is divided by the gain to obtain the block output signal value. To avoid clipping, make sure that the amplified gain falls within the range you selected.

Range

From the list, select **Bipolar -10V to +10V** or **Unipolar 0V to +10V**. This value is replicated over the channel vector.

Sample time

Enter the base sample time or a multiple of the base sample time (- 1 means sample time is inherited).

PCI slot (-1:autosearch)

If only one board of this type is in the target computer, enter - 1 to locate the board.

If two or more boards of this type are in the target computer, enter the bus number and the PCI slot number of the board associated with this driver block. Use the format **[BusNumber,SlotNumber]**.

To determine the bus number and the PCI slot number, type:

```
tg = slrt;  
getPCIInfo(tg, 'installed')
```

External Websites

- www.contec.com

Contec AD12-16(PCI)E Analog Output (D/A)

Contec AD12-16(PCI)E Analog Output block

Library

Simulink Real-Time Library for Contec

Scaling Input to Output

I/O Module Output	Block Input Data Type	Scaling
Volts	Double	1

Block Parameters

Range

From the list, select -5V to +5V, -10V to +10V, or 0 to +10V as the output range for the analog output. This range must correspond to the output range determined by the jumpers on the board.

Reset

This check box controls the behavior of the output channel at model termination. If the check box is selected, the output channel is reset to the value specified as the initial value. If the check box is not selected, the output channel remains at the most recent value attained while the model was running.

Initial value

Enter the initial voltage value for the output channel. The output channel is set to this value between the time the model is downloaded and the time the model is started. Also, if the reset check box is selected, the output channel is reset to the initial value when the model is stopped.

Sample time

Enter the base sample time or a multiple of the base sample time (-1 means sample time is inherited).

PCI slot (-1:autosearch)

If only one board of this type is in the target computer, enter - 1 to locate the board.

If two or more boards of this type are in the target computer, enter the bus number and the PCI slot number of the board associated with this driver block. Use the format **[BusNumber,SlotNumber]**.

To determine the bus number and the PCI slot number, type:

```
tg = slrt;  
getPCIInfo(tg, 'installed')
```

External Websites

- www.contec.com

Contec AD12-16U(PCI)E

Contec AD12-16U(PCI)E board

Board

Contec AD12-16U(PCI)E

General Description

The Contec AD12-16U(PCI)E is an I/O board with 16 single-ended or 8 differential analog input (A/D) channels (12 bit), one analog output channel (12 bit), 4 digital input lines, 4 digital output lines, and an i8254-compatible counter.

The Simulink Real-Time block library supports this board with these driver blocks:

- Contec AD12-16U(PCI)E Analog Input (A/D)
- Contec AD12-16U(PCI)E Analog Output (D/A)

The Simulink Real-Time software does not support the digital I/O or Counter/Timer functionality of the board.

Board Characteristics

Board name	AD12-16U(PCI)E
Manufacturer	Contec
Bus type	PCI
Access method	I/O mapped
Multiple block instance support	No
Multiple board support	Yes

External Websites

- www.contec.com

Contec AD12-16U(PCI)E Analog Input (A/D)

Contec AD12-16U(PCI)E Analog Input block

Library

Simulink Real-Time Library for Contec

Scaling Input to Output

I/O Module Input	Block Output Data Type	Scaling
Volts	Double	1

Block Parameters

Channel vector

Enter a vector of numbers to specify the input channels. For example, to use the first three analog input (A/D) channels, enter

[1, 2, 3]

The channel numbers can occur in arbitrary order. Number them beginning with 1 even if this board manufacturer numbers them beginning with 0. The maximum allowable channel number for this board is 8 (differential-ended) or 16 (single-ended).

Range

From the list, select **Bipolar -2.5V to +2.5V**, **Bipolar -5V to +5V**, **Unipolar 0V to +5V**, or **Unipolar 0V to +10V**. This value is replicated over the channel vector.

Sample time

Enter the base sample time or a multiple of the base sample time (-1 means sample time is inherited).

PCI slot (-1:autosearch)

If only one board of this type is in the target computer, enter -1 to locate the board.

If two or more boards of this type are in the target computer, enter the bus number and the PCI slot number of the board associated with this driver block. Use the format **[BusNumber,SlotNumber]**.

To determine the bus number and the PCI slot number, type:

```
tg = slrt;  
getPCIInfo(tg, 'installed')
```

External Websites

- www.contec.com

Contec AD12-16U(PCI)E Analog Output (D/A)

Contec AD12-16U(PCI)E Analog Output block

Library

Simulink Real-Time Library for Contec

Scaling Input to Output

I/O Module Output	Block Input Data Type	Scaling
Volts	Double	1

Block Parameters

Range

From the list, select -5V to +5V, -10V to +10V, or 0 to +10V as the output range for the analog output. This range must correspond to the output range determined by the jumpers on the board.

Reset

This check box controls the behavior of the output channel at model termination. If the check box is selected, the output channel is reset to the value specified as the initial value. If the check box is not selected, the output channel remains at the most recent value attained while the model was running.

Initial value

Enter the initial voltage value for the output channel. The output channel is set to this value between the time the model is downloaded and the time the model is started. Also, if the reset check box is selected, the output channel is reset to the initial value when the model is stopped.

Sample time

Enter the base sample time or a multiple of the base sample time (-1 means sample time is inherited).

PCI slot (-1:autosearch)

If only one board of this type is in the target computer, enter - 1 to locate the board.

If two or more boards of this type are in the target computer, enter the bus number and the PCI slot number of the board associated with this driver block. Use the format **[BusNumber,SlotNumber]**.

To determine the bus number and the PCI slot number, type:

```
tg = slrt;  
getPCIInfo(tg, 'installed')
```

External Websites

- www.contec.com

Contec AD12-64(PCI)

Contec AD12-64(PCI) board

Board

Contec AD12-64(PCI)

General Description

The Contec AD12-64(PCI) is an I/O board with 64 single-ended or 32 differential analog input (A/D) channels (12 bit), 4 digital input lines, and 4 digital output lines.

The Simulink Real-Time block library supports this board with these driver blocks:

- Contec AD12-64(PCI) Analog Input (A/D)
- Contec AD12-64(PCI) Digital Input
- Contec AD12-64(PCI) Digital Output

The Simulink Real-Time software does not support the Counter/Timer functionality of this board.

Board Characteristics

Board name	AD12-64(PCI)
Manufacturer	Contec
Bus type	PCI
Access method	I/O mapped
Multiple block instance support	No
Multiple board support	Yes

External Websites

- www.contec.com

Contec AD12-64(PCI) Analog Input (A/D)

Contec AD12-64(PCI) Analog Input block

Library

Simulink Real-Time Library for Contec

Scaling Input to Output

I/O Module Input	Block Output Data Type	Scaling
Volts	Double	1

Block Parameters

Channel vector

Enter a vector of numbers to specify the input channels. For example, to use the first three analog input (A/D) channels, enter

```
[ 1, 2, 3]
```

The channel numbers can occur in arbitrary order. Number them beginning with 1 even if this board manufacturer numbers them beginning with 0.

The maximum allowable channel number for this board is 32 (differential-ended) or 64 (single-ended). If the highest channel number you specify is n , the I/O module will convert all the channels between 1 and n , whether or not they occur in your channel vector. It is more efficient to specify a contiguous range of channels. (Permuting the order of such a range has little impact on efficiency however.)

Range vector

This board allows the range of each channel to be selected independently. If you enter a scalar, the value is replicated over the channel vector. If you enter a vector, it must be the same length as the channel vector.

The range vector entries must be range codes selected from the following table:

Input Range (V)	Range Code	Input Range (V)	Range Code
-10 to +10	-10	0 to 10	10
-5 to +5	-5	0 to 5	5
-2.5 to 2.5	-2	0 to 2.5	2
-1.25 to 1.25	-1	0 to 1.25	1

Polarity

Choose **single-ended** or **double-ended** (differential-ended). This value is replicated over the channel vector.

Sample time

Enter the base sample time or a multiple of the base sample time (- 1 means sample time is inherited).

PCI slot (-1:autosearch)

If only one board of this type is in the target computer, enter - 1 to locate the board.

If two or more boards of this type are in the target computer, enter the bus number and the PCI slot number of the board associated with this driver block. Use the format **[BusNumber,SlotNumber]**.

To determine the bus number and the PCI slot number, type:

```
tg = slrt;
getPCIInfo(tg, 'installed')
```

External Websites

- www.contec.com

Contec AD12-64(PCI) Digital Input

Contec AD12-64(PCI) Digital Input block

Library

Simulink Real-Time Library for Contec

Scaling Input to Output

I/O Module Input	Block Output Data Type	Scaling
TTL	Double	TTL low = 0.0 TTL high = 1.0

Block Parameters

Channel vector

Enter a vector of numbers to specify the input channels. For example, to use the first and third digital input channels enter

[1, 3]

The channel numbers can occur in arbitrary order. Number the channels beginning with 1 even if this board manufacturer numbers them beginning with 0. The maximum allowable channel number is 4.

Sample time

Enter the base sample time or a multiple of the base sample time (-1 means sample time is inherited).

PCI slot (-1:autosearch)

If only one board of this type is in the target computer, enter -1 to locate the board.

If two or more boards of this type are in the target computer, enter the bus number and the PCI slot number of the board associated with this driver block. Use the format [**BusNumber**, **SlotNumber**].

To determine the bus number and the PCI slot number, type:

```
tg = slrt;  
getPCIInfo(tg, 'installed')
```

External Websites

- www.contec.com

Contec AD12-64(PCI) Digital Output

Contec AD12-64(PCI) Digital Output block

Library

Simulink Real-Time Library for Contec

Scaling Input to Output

I/O Module Output	Block Input Data Type	Scaling
TTL	Double	< 0.5 = TTL low > 0.5 TTL high

Block Parameters

Channel vector

Enter a vector of numbers to specify the output channels. For example, to use the first and third digital output channels enter

[1, 3]

The channel numbers can occur in arbitrary order. Number the channels beginning with 1 even if this board manufacturer numbers them beginning with 0. The maximum allowable channel number is 4.

Reset vector

The reset vector controls the behavior of the channel at model termination. Enter a scalar or a vector that is the same length as the channel vector. If you specify a scalar value, that setting is replicated over the channel vector. If you specify a value of 1, the corresponding channel is reset to the value specified in the initial value vector. If you specify a value of 0, the channel remains at the last value attained while the model was running.

Initial value vector

The initial value vector contains the initial values (0 or 1) of the output channels. Enter a scalar or a vector that is the same length as the channel vector. If you enter a scalar, that value is replicated as the initial value over the channel vector. The channels are set to these initial values between the time the model is downloaded and the time it is started.

Sample time

Enter the base sample time or a multiple of the base sample time (- 1 means sample time is inherited).

PCI slot (-1:autosearch)

If only one board of this type is in the target computer, enter - 1 to locate the board.

If two or more boards of this type are in the target computer, enter the bus number and the PCI slot number of the board associated with this driver block. Use the format **[BusNumber,SlotNumber]**.

To determine the bus number and the PCI slot number, type:

```
tg = slrt;  
getPCIInfo(tg, 'installed')
```

External Websites

- www.contec.com

Contec AD16-16(PCI)E

Contec AD16-16(PCI)E board

Board

Contec AD16-16(PCI)E

General Description

The Contec AD16-16(PCI)E is an I/O board with 16 single-ended or 8 differential analog input (A/D) channels (16 bit), one analog output channel (16 bit), 4 digital input lines, 4 digital output lines, and an i8254-compatible counter.

The Simulink Real-Time block library supports this board with these driver blocks:

- Contec AD16-16(PCI)E Analog Input (A/D)
- Contec AD16-16(PCI)E Analog Output (D/A)

The Simulink Real-Time software does not support the digital I/O or Counter/Timer functionality of the board.

Board Characteristics

Board name	AD16-16(PCI)E
Manufacturer	Contec
Bus type	PCI
Access method	I/O mapped
Multiple block instance support	No
Multiple board support	Yes

External Websites

- www.contec.com

Contec AD16-16(PCI)E Analog Input (A/D)

Contec AD16-16(PCI)E Analog Input block

Library

Simulink Real-Time Library for Contec

Scaling Input to Output

I/O Module Input	Block Output Data Type	Scaling
Volts	Double	1

Block Parameters

Channel vector

Enter a vector of numbers to specify the input channels. For example, to use the first three analog input (A/D) channels, enter

```
[1, 2, 3]
```

The channel numbers can occur in arbitrary order. Number them beginning with 1 even if this board manufacturer numbers them beginning with 0. The maximum allowable channel number for this board is 8 (differential-ended) or 16 (single-ended).

Range

From the list, select **Bipolar -10V to +10V**, **Bipolar -5V to +5V**, **Unipolar 0V to +5V**, or **Unipolar 0V to +10V**. This value is replicated over the channel vector.

Sample time

Enter the base sample time or a multiple of the base sample time (-1 means sample time is inherited).

PCI slot (-1:autosearch)

If only one board of this type is in the target computer, enter -1 to locate the board.

If two or more boards of this type are in the target computer, enter the bus number and the PCI slot number of the board associated with this driver block. Use the format **[BusNumber,SlotNumber]**.

To determine the bus number and the PCI slot number, type:

```
tg = slrt;  
getPCIInfo(tg, 'installed')
```

External Websites

- www.contec.com

Contec AD16-16(PCI)E Analog Output (D/A)

Contec AD16-16(PCI)E Analog Output block

Library

Simulink Real-Time Library for Contec

Scaling Input to Output

I/O Module Output	Block Input Data Type	Scaling
Volts	Double	1

Block Parameters

Range

From the list, select -5V to +5V, -10V to +10V, or 0 to +10V as the output range for the analog output. This range must correspond to the output range determined by the jumpers on the board.

Reset

This check box controls the behavior of the output channel at model termination. If the check box is selected, the output channel is reset to the value specified as the initial value. If the check box is not selected, the output channel remains at the most recent value attained while the model was running.

Initial value

Enter the initial voltage value for the output channel. The output channel is set to this value between the time the model is downloaded and the time the model is started. Also, if the reset check box is selected, the output channel is reset to the initial value when the model is stopped.

Sample time

Enter the base sample time or a multiple of the base sample time (-1 means sample time is inherited).

PCI slot (-1:autosearch)

If only one board of this type is in the target computer, enter - 1 to locate the board.

If two or more boards of this type are in the target computer, enter the bus number and the PCI slot number of the board associated with this driver block. Use the format **[BusNumber,SlotNumber]**.

To determine the bus number and the PCI slot number, type:

```
tg = slrt;  
getPCIInfo(tg, 'installed')
```

External Websites

- www.contec.com

Contec ADI12-16(PCI)

Contec ADI12-16(PCI) board

Board

Contec ADI12-16(PCI)

General Description

The Contec ADI12-16(PCI) is an I/O board with 16 single-ended or 8 differential analog input (A/D) channels (12 bit), 4 digital input lines, and 4 digital output lines.

The Simulink Real-Time block library supports this board with these driver block:

- Contec ADI12-16(PCI) Analog Input (A/D)

Board Characteristics

Board name	ADI12-16(PCI)
Manufacturer	Contec
Bus type	PCI
Access method	I/O mapped
Multiple block instance support	No
Multiple board support	Yes

External Websites

- www.contec.com

Contec ADI12-16(PCI) Analog Input (A/D)

Contec ADI12-16(PCI) Analog Input block

Library

Simulink Real-Time Library for Contec

Scaling Input to Output

I/O Module Output	Block Input Data Type	Scaling
Volts	Double	1

Block Parameters

Channel vector

Enter a vector of numbers to specify the input channels. For example, to use the first three analog input (A/D) channels, enter

```
[1, 2, 3]
```

The channel numbers can occur in arbitrary order. Number them beginning with 1 even if this board manufacturer numbers them beginning with 0. The maximum allowable channel number for this board is 8 (differential-ended) or 16 (single-ended).

Gain vector

To specify the gain, enter 1, 2, 4, or 8 for each of the channels in the channel vector. The gain vector must be the same length as the channel vector. If you enter a scalar, the value is replicated over the channel vector.

The gain is applied to the signal prior to sampling the voltage. After the signal voltage is sampled, the result is divided by the gain to obtain the block output signal value. To avoid clipping, make sure that the amplified gain falls within the range you selected.

Range

From the list, select **Bipolar -10V to +10V**, **Unipolar 0V to +10V**, or **Unipolar 4mA to 20mA**. Choose a range that is consistent with the jumper settings on the board. This value is replicated over the channel vector.

Sample time

Enter the base sample time or a multiple of the base sample time (- 1 means sample time is inherited).

PCI slot (-1:autosearch)

If only one board of this type is in the target computer, enter - 1 to locate the board.

If two or more boards of this type are in the target computer, enter the bus number and the PCI slot number of the board associated with this driver block. Use the format **[BusNumber,SlotNumber]**.

To determine the bus number and the PCI slot number, type:

```
tg = slrt;  
getPCIInfo(tg, 'installed')
```

External Websites

- www.contec.com

Contec CNT24-4D(PCI)

Contec CNT24-4D(PCI) board

Board

Contec CNT24-4D(PCI)

General Description

The Contec CNT24-4D(PCI) is a 24-bit differential up/down counter board with four channels. This board typically connects to incremental encoders. Incremental encoders convert physical motion into electrical pulses than can be used to determine velocity, direction, and distance.

The Simulink Real-Time block library supports this board with one driver block:

- Contec CNT24-4D(PCI) Incremental Encoder

The Simulink Real-Time software does not support the timer or interrupt functionality of this board.

Board Characteristics

Board name	CNT24-4D(PCI)
Manufacturer	Contec
Bus type	PCI
Access method	I/O mapped
Multiple block instance support	No
Multiple board support	Yes

External Websites

- www.contec.com

Contec CNT24-4D(PCI) Incremental Encoder

Contec CNT24-4D(PCI) Incremental Encoder block

Library

Simulink Real-Time Library for Contec

Block Parameters

Note that you can have only one driver block instance for each physical board. If you need to use multiple channels, select and enable more than channel on the same block.

Channel

From the list, select 1, 2, 3, or 4. This parameter specifies the channel to which the subsequent parameters refer. The other parameters in this block apply to this channel. The **Enable channel** check box number changes to match the selected channel.

Enable channel

Select this check box to enable the currently selected channel. Click **OK** after you select this check box to add an output port for the channel on the driver instance of your model. This check box also enables you to set a number of operation parameters for the block, ranging from **Input type** to **Initial count**. Whatever operation parameters are in place when you click **OK** are preserved for the channel until the next time you change them.

The following are some additional behavior notes for this check box:

- If you do not select this check box for a channel, an output port for that channel is not added to the block. You also cannot change the operation parameters for the channel.
- If you select this check box and save the operation parameters for that channel, then later deselect this check box, the block preserves the operation parameters for the channel. The output port is removed from the block.

Input type

From the list, choose either **Line receiver** or **TTL-level input**. This parameter specifies the input type for the current channel.

Mode

From the list, select the counter operation mode for the current channel. There are a number of modes, based on 1-phase or 2-phase pulse inputs. See the Contec CNT24-4D(PCI) documentation for descriptions of these modes.

Note that of this list of modes, the Multiply by 4 modes are synonyms for quadrature encoding.

Direction

From the list, select either `Clockwise rotation counts down` or `Clockwise rotation counts up` as the counter direction of the current channel.

Phase Z logic

From the list, select either `Active high` or `Active low` for the current channel. This parameter specifies the state of the phase Z input (reference position signal). If the **phase Z mode** parameter has a value of `Disable phase Z input`, **Phase Z logic** does nothing.

Phase Z mode

From the list, select either `Disable phase Z input`, `Enable next phase Z input only once`, or `Enable every phase Z input`. This parameter specifies the operation mode of the phase Z input for the current channel.

Digital filter

From the list, select the characteristics of the digital input filter you want to apply to the current channel's input signal. There are a number of sampling cycles to choose from, ranging from `0.1` microseconds (1 MHz) to `1056.1` microseconds (94 Hz).

Initial count

Enter a number from `0` to `16777215` (FFFFFF hex, the largest 24-bit number). This parameter specifies the initial value of the counter for the current channel.

Sample time

Enter the base sample time or a multiple of the base sample time (`-1` means sample time is inherited).

PCI slot (-1:autosearch)

If only one board of this type is in the target computer, enter `-1` to locate the board.

If two or more boards of this type are in the target computer, enter the bus number and the PCI slot number of the board associated with this driver block. Use the format **[BusNumber,SlotNumber]**.

To determine the bus number and the PCI slot number, type:

```
tg = slrt;  
getPCIInfo(tg, 'installed')
```

External Websites

- www.contec.com

Contec CNT32-8M(PCI)

Contec CNT32-8M(PCI) board

Board

Contec CNT32-8M(PCI)

General Description

The Contec CNT32-8M(PCI) is a 32-bit high-speed up/down counter board with eight channels. This board typically connects to incremental encoders. Incremental encoders convert physical motion into electrical pulses that can be used to determine velocity, direction, and distance. The Simulink Real-Time block library supports this board with this driver block:

- Contec CNT32-8M(PCI) Incremental Encoder

Board Characteristics

Board name	CNT32-8M(PCI)
Manufacturer	Contec
Bus type	PCI
Multiple block instance support	Per model — Yes Per channel — No. To support multiple channels, use multiple blocks with each block configured to a different channel.
Multiple board support	Yes

External Websites

- www.contec.com

Contec CNT32-8M(PCI) Incremental Encoder

Contec CNT32-8M(PCI) Incremental Encoder block

Library

Simulink Real-Time Library for Contec

Note

Each channel of this block has an external input and output signal. You can configure these channels to trigger events (such as starting the encoder on the rising or falling edge of an input signal). You can also configure them for general purpose I/O, where the signals behave like digital I/O signals. The block can have the following ports:

- Output port labeled with the channel number
- Output port labeled din, if you configure the block for digital input
- Input port labeled dout, if you configure the block for digital output

Scaling

Encoder (Input to Output)

I/O Module Input	Block Input Data Type	Scaling
TTL or differential (pulse input)	Double	Counts

Digital Input (Input to Output)

I/O Module Input	Block Input Data Type	Scaling
TTL	Double	TTL low = 0.0 TTL high = 1.0

Digital Output (Output to Input)

I/O Module Output	Block Output Data Type	Scaling
TTL	Double	TTL low = < 0.5 TTL high = > 0.5

Block Parameters: Main Tab

The **Main** tab contains parameters that define the operation of the board.

Channel

From the list, select 1 through 8. This parameter specifies the board channel to which the subsequent parameters refer. Number the channels beginning with 1 even if this board manufacturer numbers them beginning with 0. The other parameters in this block apply to this channel. The channel you select becomes the label for the output port of the block.

Operation mode

From the list, select one of the following operation modes:

- 2-phase Input Synchronous Clear Multiply by 1
- 2-phase Input Synchronous Clear Multiply by 2
- 2-phase Input Synchronous Clear Multiply by 4
- 2-phase Input Asynchronous Clear Multiply by 1
- 2-phase Input Asynchronous Clear Multiply by 2
- 2-phase Input Asynchronous Clear Multiply by 4
- Single-phase Input Asynchronous Clear Multiply by 1
- Single-phase Input with Gate Control Attached Asynchronous Clear Multiply 1
- Single-phase Input with Gate Control Attached Asynchronous Clear Multiply 2

See the Contec CNT32-8M(PCI) 8-Ch 32-Bit Up/Down High-Speed Counter Board for PCI documentation for definitions of these modes.

Digital filter

From the list, select the desired digital filter time, in microseconds. To disable digital filtering, select `No filtering`.

Pulse input

From the list, select one of the following pulse inputs:

- Differential line receiver input
- TTL Level input

You can connect the CNT32-8M(PCI) board to either differential or TTL input signals. See the Contec CNT32-8M(PCI) 8-Ch 32-Bit Up/Down High-Speed Counter Board for PCI documentation for connection details.

Direction

From the list, select one of the following count directions:

- Up in the clockwise direction/Down in the counterclockwise direction
- Down in the clockwise direction/Up in the counterclockwise direction

The board can count either up or down in the clockwise direction.

Initial value

Enter a number from 0 to the largest 32-bit number. This parameter specifies the initial value of the counter before the model begins.

Load initial value

Select this check box to load the value from **Initial value** into the counter, overwriting the previous count value. If you do not select this check box, the driver does not load the initial value, preserving the previous count value.

Sample time

Enter the base sample time or a multiple of the base sample time (- 1 means sample time is inherited).

PCI slot (-1:autosearch)

If only one board of this type is in the target computer, enter - 1 to locate the board.

If two or more boards of this type are in the target computer, enter the bus number and the PCI slot number of the board associated with this driver block. Use the format [**BusNumber**, **SlotNumber**].

To determine the bus number and the PCI slot number, type:

```
tg = slrt;  
getPCIInfo(tg, 'installed')
```

Block Parameters: Counter Control Tab

The **Counter Control** tab contains parameters that define

- How to start and stop counting
- How to use the external input signal
- Under what circumstances to reset the counter

Start method

Directs counter to begin counting under one of the following conditions:

- **Model Start** — Begin counting when model starts.
- **External Input Rising** — Begin counting when external TTL input rises.
- **External Input Falling** — Begin counting when external TTL input falls.
- **Disable** — Do not begin counting.

Stop method

Directs counter to stop counting under one of the following conditions:

- **Model Terminate** — Stop counting when model stops.
- **External Input Rising** — Stop counting when external TTL input rises.
- **External Input Falling** — Stop counting when external TTL input falls.
- **Free Running** — Do not stop counting.

Zero-clear external input rising

Select this check box to clear the counter upon a rising edge on the external input signal.

Zero-clear external input falling

Select this check box to clear the counter upon a falling edge on the external input signal.

Zero-clear match 0

Select this check box to clear the counter when the counter has the same value as that contained in the **Match 0 value** parameter.

Zero-clear match 1

Select this check box to clear the counter when the counter has the same value as that contained in the **Match 1 value** parameter.

Preset external input rising

Select this check box to preset the counter to the value contained in the **Preset value** parameter upon a rising edge on the external input signal.

Preset external input falling

Select this check box to preset the counter to the value contained in the **Preset value** parameter upon a falling edge on the external input signal.

Preset match 0

Select this check box to preset the counter to the value contained in the **Preset value** parameter when the counter value has the same value as that contained in the **Match 0 value** parameter.

Preset match 1

Select this check box to preset the counter to the value contained in the **Preset value** parameter when the counter value has the same value as that contained in the **Match 1 value** parameter.

Preset value

Enter the value that you want the counter to reset when a preset condition occurs.

Match 0 value

Enter the value that you want the counter value to be compared to for the **Zero-clear match 0** or **Preset match 0** conditions.

Match 1 value

Enter the value that you want the counter value to be compared to for the **Zero-clear match 1** or **Preset match 1** conditions.

Block Parameters: Signals Tab

The **Signals** tab contains parameters that

- Control the optional use of the external output signal
- Control the encoder index signal

- Enable the external signals for general purpose

Output signal match 0

Select this check box to strobe the output signal when the counter value has the same value as the **Match 0 parameter**.

Output signal match 1

Select this check box to strobe the output signal when the counter value has the same value as the **Match 1 parameter**.

Output signal abnormal input error

Select this check box to strobe the output signal when the phase-A and phase-B signals change at the same time.

Output signal digital filter error

Select this check box to strobe the output signal when a pulse is faster than the digital filter time setting.

Output signal disconnection alarm error

Select this check box to strobe the output signal when both the positive and negative differential inputs are high.

One-shot duration

From the list, select the pulse width of the output signal for the one-shot duration, in microseconds or milliseconds.

Index enable

From the list, select the following to enable or disable the phase-Z/CLR input signal:

- **Disable** — Disables phase-Z input (select this option if phase-Z does not exist).
- **Enable Once** — Enables only the next phase-Z input.
- **Enable All** — Enables all of the phase-Z inputs.

Index logic

From the list, select one of the following to set the logic of the phase-Z input signal. Setting **Index enable** to **Enable Once** or **Enable All** activates this parameter.

- **Positive (Active High)**
- **Negative (Active Low)**

Enable digital input

Select this check box to enable the external input signal to be used as a general purpose digital input. Even if you select an external input signal other than general-purpose input, the block can still read the input level.

Enable digital output

Select this check box to enable the external output signal to be used as a general-purpose digital output. If you select an external output signal other than general purpose, the block cannot write the output level. Selecting this check box enables the **Digital output initial value** and **Digital output final value** parameters.

Digital output initial value

From the list, select how you want to set the initial value of the digital output when the model starts:

- **None** — Do not modify the output value.
- **Set** — Set the bit.
- **Clear** — Clear the bit.

Digital output final value

From the list, select how you want to set the final value of the digital output when the model terminates:

- **None** — Do not modify the output value.
- **Set** — Set the bit.
- **Clear** — Clear the bit.

External Websites

- www.contec.com

Contec DA12-16(PCI)

Contec DA12-16(PCI) block

Board

Contec DA12-16(PCI)

General Description

The Contec DA12-16(PCI) is an I/O board with 16 analog output (D/A) channels (12 bit).

The Simulink Real-Time block library supports this board with this driver block:

- Contec DA12-16(PCI) Analog Output (D/A)

The Simulink Real-Time software does not support the timer, external trigger, or interrupt functionality of this board.

Board Characteristics

Board name	DA12-16(PCI)
Manufacturer	Contec
Bus type	PCI
Access method	I/O mapped
Multiple block instance support	No
Multiple board support	Yes

External Websites

- www.contec.com

Contec DA12-16(PCI) Analog Output (D/A)

Contec DA12-16(PCI) Analog Output block

Library

Simulink Real-Time Library for Contec

Scaling Input to Output

I/O Module Output	Block Input Data Type	Scaling
Volts	Double	1

Block Parameters

Channel vector

Enter a vector of numbers to specify the output channels. For example, to use the first and second analog output (D/A) channels enter

[1, 2]

The channel numbers can occur in arbitrary order. Number the channels beginning with 1 even if this board manufacturer numbers them beginning with 0. The maximum allowable channel number is 16.

Range

This board allows the range of each channel to be selected independently. Enter a scalar, in which case the same range is replicated over the analog output channel vector, or a vector the same length as the channel vector.

The range vector entries must be range codes selected from the following table:

Input Range (V)	Range Code
-10 to +10	-10
-5 to +5	-5

Input Range (V)	Range Code
-2.5 to 2.5	-2

For example, if the first and second channel is -5 to +5 volts, enter [-5,-5]

Reset vector

The reset vector controls the behavior of the channel at model termination. Enter a scalar or a vector that is the same length as the channel vector. If you specify a scalar value, that setting is replicated over the channel vector. If you specify a value of 1, the corresponding channel is reset to the value specified in the initial value vector. If you specify a value of 0, the channel remains at the last value attained while the model was running.

Initial value vector

The initial value vector contains the initial voltage values for the output channels. Enter a scalar or a vector that is the same length as the channel vector. If you specify a scalar value, that value is replicated as the initial value over the channel vector. The channels are set to the initial values between the time the model is downloaded and the time it is started.

Sample time

Enter the base sample time or a multiple of the base sample time (- 1 means sample time is inherited).

PCI slot (-1:autosearch)

If only one board of this type is in the target computer, enter - 1 to locate the board.

If two or more boards of this type are in the target computer, enter the bus number and the PCI slot number of the board associated with this driver block. Use the format [**BusNumber,SlotNumber**].

To determine the bus number and the PCI slot number, type:

```
tg = slrt;
getPCIInfo(tg, 'installed')
```

External Websites

- www.contec.com

Contec DA12-4(PCI)

Contec DA12-4(PCI) board

Board

Contec DA12-4(PCI)

General Description

The Contec DA12-4(PCI) is an I/O board with 4 analog output (D/A) channels (12 bit).

The Simulink Real-Time block library supports this board with this driver block:

- Contec DA12-4(PCI) Analog Output (D/A)

The Simulink Real-Time software does not support the timer, external trigger, or interrupt functionality of this board.

Board Characteristics

Board name	DA12-4(PCI)
Manufacturer	Contec
Bus type	PCI
Access method	I/O mapped
Multiple block instance support	No
Multiple board support	Yes

External Websites

- www.contec.com

Contec DA12-4(PCI) Analog Output (D/A)

Contec DA12-4(PCI) Analog Output block

Library

Simulink Real-Time Library for Contec

Scaling Input to Output

I/O Module Output	Block Input Data Type	Scaling
Volts	Double	1

Block Parameters

Channel vector

Enter a vector of numbers to specify the output channels. For example, to use the first and second analog output (D/A) channels enter

[1, 2]

The channel numbers can occur in arbitrary order. Number the channels beginning with 1 even if this board manufacturer numbers them beginning with 0. The maximum allowable channel number is 4.

Reset vector

The reset vector controls the behavior of the channel at model termination. Enter a scalar or a vector that is the same length as the channel vector. If you specify a scalar value, that setting is replicated over the channel vector. If you specify a value of 1, the corresponding channel is reset to the value specified in the initial value vector. If you specify a value of 0, the channel remains at the last value attained while the model was running.

Initial value vector

The initial value vector contains the initial voltage values for the output channels. Enter a scalar or a vector that is the same length as the channel vector. If you specify

a scalar value, that value is replicated as the initial value over the channel vector. The channels are set to the initial values between the time the model is downloaded and the time it is started.

Sample time

Enter the base sample time or a multiple of the base sample time (- 1 means sample time is inherited).

PCI slot (-1:autosearch)

If only one board of this type is in the target computer, enter - 1 to locate the board.

If two or more boards of this type are in the target computer, enter the bus number and the PCI slot number of the board associated with this driver block. Use the format **[BusNumber,SlotNumber]**.

To determine the bus number and the PCI slot number, type:

```
tg = slrt;  
getPCIInfo(tg, 'installed')
```

External Websites

- www.contec.com

Contec PI-64L(PCI)H

Contec PI-64L(PCI)H board

Board

Contec PI-64L(PCI)H

General Description

The Contec PI-64L(PCI)H is a digital input board with 64 digital input channels. The supporting block can control up to 32 bits that you can configure as either a single 32-bit port (Single 32-bit Port mode) or up to 32 1-bit channels (32 1-bit Channels mode).

The Simulink Real-Time block library supports this board with this driver block:

- Contec PI-64L(PCI)H Digital Input

Board Characteristics

Board name	PI-64L(PCI)H
Manufacturer	Contec
Bus type	PCI
Multiple block instance support	No
Multiple board support	Yes

External Websites

- www.contec.com

Contec PI-64L(PCI)H Digital Input

Contec PI-64L(PCI)H Digital Input block

Library

Simulink Real-Time Library for Contec

Scaling Input to Output

I/O Module Input	Block Output Data Type	Scaling
TTL	Double (Format:32 1-bit Channels)	Double: TTL low = 0.0 TTL high = 1.0
	uint32 (Format:Single 32-bit Port)	uint32: TTL low corresponding bit is clear TTL high corresponding bit is set

Block Parameters

Format

From the list, select either

- **32 1-bit Channels** — Indicates that the channel vector specifies the configuration of the block. Each output is a double with value of 0 or 1. The value is 0 when the input voltage is low.
- **Single 32-bit Port** — Indicates that the output from the block is a 32-bit integer where all 32 bits on the board feed into the single output. The least significant bit is the lowest numbered bit in the Contec documentation.

If you choose this mode, use the bit packing and unpacking blocks (Digital I/O Bit-Packing and Digital I/O Bit-Unpacking) to construct the required data frames.

Group

From the list, select either

- **A (Bits 0-31)** — Selects the 32-bit word from group A to address.
- **B (Bits 32-63)** — Selects the 32-bit word from group B to address.

Channel vector

(32 1-bit Channels mode only) Enter a vector of numbers to specify the output channels. For example, to use the first and third digital input channels, enter

[1, 3]

This vector indexes into group A or B channels. For group A, channel vector [1, 3] specifies channels 0 and 2. For group B, channel vector [1, 3] specifies channels 32 and 34.

The channel numbers can occur in arbitrary order, but the numbers must be in the range 1 to 32.

Digital Filter

This parameter specifies the digital filter time. From the list, select

- **No filtering**
- **0.25 usec**
- **0.5 usec**
- **1 usec**
- **2 usec**
- **4 usec**
- **8 usec**

See the Contec documentation for further details on the digital filter time.

Sample time

Enter the base sample time or a multiple of the base sample time (-1 means sample time is inherited).

PCI slot (-1:autosearch)

If only one board of this type is in the target computer, enter -1 to locate the board.

If two or more boards of this type are in the target computer, enter the bus number and the PCI slot number of the board associated with this driver block. Use the format [**BusNumber,SlotNumber**].

To determine the bus number and the PCI slot number, type:

```
tg = slrt;  
getPCIInfo(tg, 'installed')
```

External Websites

- www.contec.com

Contec PIO-32/32F(PCI)

Contec PIO-32/32F(PCI) board

Board

Contec PIO-32/32F(PCI)

General Description

The Contec PIO-32/32F(PCI) is an opto-isolated high-speed I/O board with 32 digital input channels and 32 output channels.

The Simulink Real-Time block library supports this board with these driver blocks:

- Contec PIO-32/32T(PCI) Digital Input
- Contec PIO-32/32T(PCI) Digital Output

The Simulink Real-Time software does not support the timer, external trigger, or interrupt functionality of this board.

Board Characteristics

Board name	PIO-32/32F(PCI)
Manufacturer	Contec
Bus type	PCI
Multiple block instance support	No
Multiple board support	Yes

External Websites

- www.contec.com

Contec PIO-32/32F(PCI) Digital Input

Contec PIO-32/32F(PCI) Digital Input block

Library

Simulink Real-Time Library for Contec

Scaling Input to Output

I/O Module Input	Block Output Data Type	Scaling
TTL	Double	TTL low = 0.0 TTL high = 1.0

Block Parameters

I/O format

Select **serial** or **parallel**. If you select **serial**, the block is configured to accept up to 32 one-bit input channels. If you select **parallel**, the block is configured to accept a single 32-bit input channel and the channel vector parameter is unavailable.

Channel vector

If you selected **serial** I/O format, enter a vector of numbers to specify the input channels for serial I/O format. For example, to use the first and third digital input channels, enter

[1, 3]

The channel numbers can occur in arbitrary order, but the numbers must be in the range 1 to 32.

Sample time

Enter the base sample time or a multiple of the base sample time (-1 means sample time is inherited).

PCI slot (-1:autosearch)

If only one board of this type is in the target computer, enter - 1 to locate the board.

If two or more boards of this type are in the target computer, enter the bus number and the PCI slot number of the board associated with this driver block. Use the format **[BusNumber,SlotNumber]**.

To determine the bus number and the PCI slot number, type:

```
tg = slrt;  
getPCIInfo(tg, 'installed')
```

External Websites

- www.contec.com

Contec PIO-32/32F(PCI) Digital Output

Contec PIO-32/32F(PCI) Digital Output block

Library

Simulink Real-Time Library for Contec

Scaling Input to Output

I/O Module Output	Block Input Data Type	Scaling
TTL	Double	< 0.5 = TTL low > 0.5 = TTL high

Block Parameters

I/O format

Select **serial** or **parallel**. If you select **serial**, the block is configured to accept up to 32 one-bit input channels for output. If you select **parallel**, the block is configured to accept a single 32-bit channel and the channel vector parameter is unavailable.

Channel vector

For **serial** I/O format, enter a vector of numbers to specify the output channels. For example, to use the first and third digital output channels, enter

```
[1, 3]
```

The channel numbers can occur in arbitrary order, but the numbers must be in the range 1 to 32.

Reset vector

The reset vector controls the behavior of the channel at model termination. Enter a scalar or a vector that is the same length as the channel vector. If you specify a scalar value, that setting is replicated over the channel vector. If you specify a value of 1, the corresponding channel is reset to the value specified in the initial value vector.

If you specify a value of 0, the channel remains at the last value attained while the model was running.

Initial value vector

The initial value vector contains the initial voltage values (0 or 1) for the output channels. Enter a scalar or a vector that is the same length as the channel vector. If you specify a scalar value, that value is replicated as the initial value over the channel vector. The channels are set to the initial values between the time the model is downloaded and the time it is started. If you selected `parallel` I/O format, the values can be in the form `[hex2dec('fffffff')]`.

Sample time

Enter the base sample time or a multiple of the base sample time (- 1 means sample time is inherited).

PCI slot (-1:autosearch)

If only one board of this type is in the target computer, enter - 1 to locate the board.

If two or more boards of this type are in the target computer, enter the bus number and the PCI slot number of the board associated with this driver block. Use the format **[BusNumber, SlotNumber]**.

To determine the bus number and the PCI slot number, type:

```
tg = slrt;  
getPCIInfo(tg, 'installed')
```

External Websites

- www.contec.com

Contec PIO-32/32L(PCI)H

Contec PIO-32/32L(PCI)H board

Board

Contec PIO-32/32L(PCI)H

General Description

The Contec PIO-32/32L(PCI)H is an I/O board with 32 digital input channels and 32 output channels. Each supporting block can control up to 32 bits that you can configure as either a single 32-bit port (**Single 32-bit Port mode**) or up to 32 1-bit channels (**32 1-bit Channels mode**).

The Simulink Real-Time block library supports this board with these driver blocks:

- Contec PIO-32/32L(PCI)H Digital Input
- Contec PIO-32/32L(PCI)H Digital Output

The Simulink Real-Time software does not support the timer, external trigger, or interrupt functionality of this board.

Board Characteristics

Board name	PIO-32/32L(PCI)H
Manufacturer	Contec
Bus type	PCI
Multiple block instance support	Yes
Multiple board support	Yes

External Websites

- www.contec.com

Contec PIO-32/32L(PCI)H Digital Input

Contec PIO-32/32L(PCI)H Digital Input block

Library

Simulink Real-Time Library for Contec

Scaling Input to Output

I/O Module Input	Block Output Data Type	Scaling
TTL	Double (Format:32 1-bit Channels)	Double: TTL low = 0.0
	uint32 (Format:Single 32-bit Port)	TTL high = 1.0 uint32: TTL low corresponding bit is clear TTL high corresponding bit is set

Block Parameters

Format

From the list, select either

- **32 1-bit Channels** — Indicates that the channel vector specifies the configuration of the block. Each output is a double with value of 0 or 1. The value is 0 when the input voltage is low.
- **Single 32-bit Port** — Indicates that the output from the block is a 32-bit integer where all 32 bits on the board feed into the single output. The least significant bit is the lowest numbered bit in the manufacturer documentation.

If you choose this mode, use the bit packing and unpacking blocks (Digital I/O Bit-Packing and Digital I/O Bit-Unpacking) to construct the required data frames.

Channel vector

(32 1-bit Channels mode only) Enter a vector of numbers to specify the output channels. For example, to use the first and third digital output channels, enter

```
[1, 3]
```

The channel numbers can occur in arbitrary order, but the numbers must be in the range 1 to 32.

Digital Filter

This parameter specifies the digital filter time. From the list, select

- No filtering
- 0.25 usec
- 0.5 usec
- 1 usec
- 2 usec
- 4 usec
- 8 usec

See the Contec User Guide for further details on the digital filter time.

Sample time

Enter the base sample time or a multiple of the base sample time (- 1 means sample time is inherited).

PCI slot (-1:autosearch)

If only one board of this type is in the target computer, enter - 1 to locate the board.

If two or more boards of this type are in the target computer, enter the bus number and the PCI slot number of the board associated with this driver block. Use the format [**BusNumber**, **SlotNumber**].

To determine the bus number and the PCI slot number, type:

```
tg = slrt;  
getPCIInfo(tg, 'installed')
```

External Websites

- www.contec.com

Contec PIO-32/32L(PCI)H Digital Output

Contec PIO-32/32L(PCI)H Digital Output block

Library

Simulink Real-Time Library for Contec

Scaling Input to Output

I/O Module Output	Block Input Data Type	Scaling
TTL	Double (Format:32 1-bit Channels)	Double: < 0.5 = TTL low
	uint32 (Format:Single 32-bit Port)	>0.5 = TTL high uint32: Bit clear = TTL low Bit set = TTL high

Block Parameters

Format

From the list, select either

- **32 1-bit Channels** — Indicates that the channel vector specifies the configuration of the block. Each output is a double with value of 0 or 1. The value is 0 when the input voltage is low.
- **Single 32-bit Port** — Indicates that the output from the block is a 32-bit integer where all 32 bits on the board feed into the single output. The least significant bit is the lowest numbered bit in the manufacturer documentation.

If you choose this mode, use the bit packing and unpacking blocks (Digital I/O Bit-Packing and Digital I/O Bit-Unpacking) to construct the required data frames.

Channel vector

(32 1-bit Channels mode only) Enter a vector of numbers to specify the output channels. For example, to use the first and third digital output channels, enter

```
[1, 3]
```

The channel numbers can occur in arbitrary order, but the numbers must be in the range 1 to 32.

Initial value vector

The initial value vector contains the initial voltage values for the output channels. Enter a scalar or a vector that is the same length as the channel vector. If you specify a scalar value, that value is replicated as the initial value over the channel vector. The channels are set to the initial values between the time the model is downloaded and the time it is started.

Final action vector

The final action vector controls the behavior of the channel at model termination. Enter a scalar or a vector that is the same length as the channel vector. If you specify a scalar value, that setting is replicated over the channel vector. If you specify a value of 1, the corresponding channel is reset to the value specified in the initial value vector. If you specify a value of -1, the block sets the channel to the value specified in the **Final value vector** value for that channel. If you specify a value of 0, the channel remains at the last value attained while the model was running.

Final value vector

The final value vector contains the final value for each output channel. Enter a scalar or a vector that is the same length as the channel vector. If you specify a scalar value, that setting is replicated over the channel vector. If the **Final action vector** is -1, the block sets the channel to this value on model termination.

Sample time

Enter the base sample time or a multiple of the base sample time (-1 means sample time is inherited).

PCI slot (-1:autosearch)

If only one board of this type is in the target computer, enter -1 to locate the board.

If two or more boards of this type are in the target computer, enter the bus number and the PCI slot number of the board associated with this driver block. Use the format [**BusNumber,SlotNumber**].

To determine the bus number and the PCI slot number, type:

```
tg = slrt;  
getPCIInfo(tg, 'installed')
```

External Websites

- www.contec.com

Contec PIO-32/32T(PCI)

Contec PIO-32/32T(PCI) board

Board

Contec PIO-32/32T(PCI)

General Description

The Contec PIO-32/32T(PCI) is an I/O board with 32 digital input channels and 32 output channels.

The Simulink Real-Time block library supports this board with these driver blocks:

- Contec PIO-32/32T(PCI) Digital Input
- Contec PIO-32/32T(PCI) Digital Output

The Simulink Real-Time software does not support the timer, external trigger, or interrupt functionality of this board.

Board Characteristics

Board name	PIO-32/32T(PCI)
Manufacturer	Contec
Bus type	PCI
Multiple block instance support	No
Multiple board support	Yes

External Websites

- www.contec.com

Contec PIO-32/32T(PCI) Digital Input

Contec PIO-32/32T(PCI) Digital Input block

Library

Simulink Real-Time Library for Contec

Scaling Input to Output

I/O Module Input	Block Output Data Type	Scaling
TTL	Double	TTL low = 0.0 TTL high = 1.0

Block Parameters

I/O format

Select **serial** or **parallel**. If you select **serial**, the block is configured to accept up to 32 one-bit input channels. If you select **parallel**, the block is configured to accept a single 32-bit input channel and the channel vector parameter is unavailable.

Channel vector

If you selected **serial** I/O format, enter a vector of numbers to specify the input channels for serial I/O format. For example, to use the first and third digital input channels, enter

[1, 3]

The channel numbers can occur in arbitrary order, but the numbers must be in the range 1 to 32.

Sample time

Enter the base sample time or a multiple of the base sample time (-1 means sample time is inherited).

PCI slot (-1:autosearch)

If only one board of this type is in the target computer, enter - 1 to locate the board.

If two or more boards of this type are in the target computer, enter the bus number and the PCI slot number of the board associated with this driver block. Use the format **[BusNumber,SlotNumber]**.

To determine the bus number and the PCI slot number, type:

```
tg = slrt;  
getPCIInfo(tg, 'installed')
```

External Websites

- www.contec.com

Contec PIO-32/32T(PCI) Digital Output

Contec PIO-32/32T(PCI) Digital Output block

Library

Simulink Real-Time Library for Contec

Scaling Input to Output

I/O Module Output	Block Input Data Type	Scaling
TTL	Double	< 0.5 = TTL low > 0.5 TTL high

Block Parameters

I/O format

Select **serial** or **parallel**. If you select **serial**, the block is configured to accept up to 32 one-bit input channels for output. If you select **parallel**, the block is configured to accept a single 32-bit channel and the channel vector parameter is unavailable.

Channel vector

For **serial** I/O format, enter a vector of numbers to specify the output channels. For example, to use the first and third digital output channels, enter

```
[1, 3]
```

The channel numbers can occur in arbitrary order, but the numbers must be in the range 1 to 32.

Reset vector

The reset vector controls the behavior of the channel at model termination. Enter a scalar or a vector that is the same length as the channel vector. If you specify a scalar value, that setting is replicated over the channel vector. If you specify a value of 1, the corresponding channel is reset to the value specified in the initial value vector.

If you specify a value of 0, the channel remains at the last value attained while the model was running.

Initial value vector

The initial value vector contains the initial voltage values (0 or 1) for the output channels. Enter a scalar or a vector that is the same length as the channel vector. If you specify a scalar value, that value is replicated as the initial value over the channel vector. The channels are set to the initial values between the time the model is downloaded and the time it is started. If you selected `parallel` I/O format, the values can be in the form `[hex2dec('fffffff')]`.

Sample time

Enter the base sample time or a multiple of the base sample time (- 1 means sample time is inherited).

PCI slot (-1:autosearch)

If only one board of this type is in the target computer, enter - 1 to locate the board.

If two or more boards of this type are in the target computer, enter the bus number and the PCI slot number of the board associated with this driver block. Use the format **[BusNumber, SlotNumber]**.

To determine the bus number and the PCI slot number, type:

```
tg = slrt;  
getPCIInfo(tg, 'installed')
```

External Websites

- www.contec.com

Contec PO-64L(PCI)H

Contec PO-64L(PCI)H board

Board

Contec PO-64L(PCI)H

General Description

The Contec PO-64L(PCI)H is a digital output board with 64 digital output channels. The supporting block can control up to 32 bits that you can configure as either a single 32-bit port (**Single 32-bit Port mode**) or up to 32 1-bit channels (**32 1-bit Channels mode**).

The Simulink Real-Time block library supports this board with this driver block:

- Contec PO-64L(PCI)H Digital Output

Board Characteristics

Board name	PO-64L(PCI)H
Manufacturer	Contec
Bus type	PCI
Multiple block instance support	Yes — for 32 1-bit Channels mode
Multiple board support	Yes

External Websites

- www.contec.com

Contec PO-64L(PCI)H Digital Output

Contec PO-64L(PCI)H Digital Output block

Library

Simulink Real-Time Library for Contec

Scaling Input to Output

I/O Module Output	Block Input Data Type	Scaling
TTL	Double (Format:32 1-bit Channels)	Double: < 0.5 = TTL low
	uint32 (Format:Single 32-bit Port)	>0.5 = TTL high uint32: Bit clear = TTL low Bit set = TTL high

Block Parameters

Format

From the list, select either

- **32 1-bit Channels** — Indicates that the channel vector specifies the configuration of the block. Each output is a double with value of 0 or 1. The value is 0 when the input voltage is low.

With this mode, the block reads, modifies, then writes the data. This enables you to use multiple instances of this block, with each block addressing a different bit. However, for efficiency, use a single block for each 32-bit group. Use multiple block instances only if your model requires multiple accesses.

- **Single 32-bit Port** — Indicates that the output from the block is a 32-bit integer where all 32 bits on the board feed into the single output. The least significant bit is the lowest numbered bit in the manufacturer documentation.

If you choose this mode, use the bit packing and unpacking blocks (Digital I/O Bit-Packing and Digital I/O Bit-Unpacking) to construct the required data frames.

Group

From the list, select either

- **A (Bits 0-31)** — Selects the 32-bit word from Group A to address.
- **B (Bits 32-63)** — Selects the 32-bit word from Group B to address.

Channel vector

(32 1-bit Channels mode only) Enter a vector of numbers to specify the output channels. For example, to use the first and third digital output channels, enter

[1, 3]

This vector indexes into group A or B channels. For group A, channel vector [1, 3] specifies channels 0 and 2. For group B, channel vector [1, 3] specifies channels 32 and 34.

The channel numbers can occur in arbitrary order, but the numbers must be in the range 1 to 32.

Initial value vector

The initial value vector contains the initial voltage values for the output channels. Enter a scalar or a vector that is the same length as the channel vector. If you specify a scalar value, that value is replicated as the initial value over the channel vector. The channels are set to the initial values between the time the model is downloaded and the time it is started.

Final action vector

The final action vector controls the behavior of the channel at model termination. Enter a scalar or a vector that is the same length as the channel vector. If you specify a scalar value, that setting is replicated over the channel vector. If you specify a value of 1, the corresponding channel is reset to the value specified in the initial value vector. If you specify a value of -1, the block sets the channel to the value specified in the **Final value vector** value for that channel. If you specify a value of 0, the channel remains at the last value attained while the model was running.

Final value vector

The final value vector contains the final value for each output channel. Enter a scalar or a vector that is the same length as the channel vector. If you specify a scalar value, that setting is replicated over the channel vector. If the **Final action vector** is -1, the block sets the channel to this value on model termination.

Sample time

Enter the base sample time or a multiple of the base sample time (- 1 means sample time is inherited).

PCI slot (-1:autosearch)

If only one board of this type is in the target computer, enter - 1 to locate the board.

If two or more boards of this type are in the target computer, enter the bus number and the PCI slot number of the board associated with this driver block. Use the format [**BusNumber,SlotNumber**].

To determine the bus number and the PCI slot number, type:

```
tg = slrt;  
getPCIInfo(tg, 'installed')
```

External Websites

- www.contec.com

Curtiss-Wright Electronic Systems Blocks

Systran SCRAMNet+ SC150 PCI
Systran SC150 init
Systran SC150 read
Systran SC150 rearm
Systran SC150 write

Systran SCRAMNet+ SC150 PCI

Support for Systran SCRAMNet+ SC150 PCI real-time reflective memory board

Board

Systran SCRAMNet+ SC150 PCI

General Description

The SCRAMNet+ SC150 PCI board is a real-time reflective PCI memory board. It can also generate/broadcast interrupts. The Simulink Real-Time software uses this board as part of the shared memory network that you can use to exchange data between computer nodes.

The Systran block library supports this board with these driver blocks:

- Systran SC150 init
- Systran SC150 read
- Systran SC150 write
- Systran SC150 rearm

For information about the Change endianness block, see [Byte Reversal/Change Endianness](#).

Board Characteristics

Board name	SCRAMNet+ SC150
Manufacturer	Curtiss-Wright Electronic Systems (formerly Systran)
Bus type	PCI
Access method	Memory mapped
Multiple block instance support	Yes

Multiple board support

Yes

External Websites

- www.cwcelectronicssystem.com

Systran SC150 init

SystranSC150 init block

Library

Simulink Real-Time Library for Systran

Note

Before you begin to configure these block parameters, be sure that you have a predefined node initialization structure. See “Initialize Curtiss-Wright Shared Nodes” on page 24-26.

Block Parameters

Each model that uses shared memory must have one SC150 init block for every SCRAMNet+ SC150 board in the system.

Node struct

Enter the name of the predefined node initialization structure.

PCI slot (-1:autosearch)

If only one board of this type is in the target computer, enter - 1 to locate the board.

If two or more boards of this type are in the target computer, enter the bus number and the PCI slot number of the board associated with this driver block. Use the format [**BusNumber**, **SlotNumber**].

To determine the bus number and the PCI slot number, type:

```
tg = slrt;  
getPCIInfo(tg, 'installed')
```

External Websites

- www.cwcelectronicssystem.com

Systran SC150 read

Systran SC150 read block

Library

Simulink Real-Time Library for Systran

Note

Before you begin to configure this block, be sure that you have a predefined shared memory partition structure. The SC150 read block requires this structure to specify how Simulink signal values are mapped in the shared memory. It also uses this structure to determine the total size and address of the shared memory. See “Create Curtiss-Wright Shared Partitions” on page 24-24.

Block Parameters

Partition struct

Enter the name of the predefined shared memory partition structure. The block uses this structure to specify how Simulink signal values map into shared memory.

Error port

Select this check box to monitor the status of the Systran Scramnet board CSR1 register modes. The enabled port is of type `uint16`.

Sampletime

Enter the base sample time or a multiple of the base sample time (-1 means sample time is inherited)

PCI slot (-1:autosearch)

If only one board of this type is in the target computer, enter -1 to locate the board.

If two or more boards of this type are in the target computer, enter the bus number and the PCI slot number of the board associated with this driver block. Use the format **[BusNumber,SlotNumber]**.

To determine the bus number and the PCI slot number, type:

```
tg = slrt;  
getPCIInfo(tg, 'installed')
```

External Websites

- www.cwcelectronicssystem.com

Systran SC150 rearm

Systran SC150 rearm block

Library

Simulink Real-Time Library for Systran

Note

Before you begin to configure this block, be sure that you have a predefined shared memory partition structure. The SC150 rearm block requires this structure to specify how Simulink signal values are mapped in the shared memory. It also uses this structure to determine the total size and address of the shared memory. See “Create Curtiss-Wright Shared Partitions” on page 24-24.

Block Parameters

Partition struct

Enter the name of the predefined shared memory partition structure. The block uses this structure to specify how Simulink signal values map into shared memory.

Sampletime

Enter the base sample time or a multiple of the base sample time (-1 means sample time is inherited)

PCI slot (-1:autosearch)

If only one board of this type is in the target computer, enter -1 to locate the board.

If two or more boards of this type are in the target computer, enter the bus number and the PCI slot number of the board associated with this driver block. Use the format [**BusNumber**, **SlotNumber**].

To determine the bus number and the PCI slot number, type:

```
tg = slrt;  
getPCIInfo(tg, 'installed')
```

External Websites

- www.cwcelectronicssystem.com

Systran SC150 write

Systran SC150 write block

Library

Simulink Real-Time Library for Systran

Note

Before you begin to configure this block, be sure that you have a predefined shared memory partition structure. The SC150 write block requires this structure to specify how Simulink signal values are mapped in the shared memory. It also uses this structure to determine the total size and address of the shared memory. See “Create Curtiss-Wright Shared Partitions” on page 24-24.

Block Parameters

Partition struct

Enter the name of the predefined shared memory partition structure. The block uses this structure to specify how Simulink signal values map into shared memory.

Error port

Select this check box to monitor the status of the Systran Scramnet board CSR1 register modes. The enabled port is of type `uint16`.

Sampletime

Enter the base sample time or a multiple of the base sample time (-1 means sample time is inherited)

PCI slot (-1:autosearch)

If only one board of this type is in the target computer, enter -1 to locate the board.

If two or more boards of this type are in the target computer, enter the bus number and the PCI slot number of the board associated with this driver block. Use the format **[BusNumber,SlotNumber]**.

To determine the bus number and the PCI slot number, type:

```
tg = slrt;  
getPCIInfo(tg, 'installed')
```

External Websites

- www.cwcelectronicssystem.com

Diamond, FlexRay

Diamond

This topic describes Diamond Systems I/O boards supported by the Simulink Real-Time product (www.diamondsystems.com). To read about the Diamond Systems serial communications boards supported by Simulink Real-Time, see “RS-232/422/485 Drivers (Composite)” on page 2-5.

Diamond Diamond-MM

Diamond Diamond-MM board

Board

Diamond Diamond-MM

General Description

The Diamond-MM is a DAS16 compatible I/O board with 16 single or 8 differential analog input (A/D) channels (12-bit) with a maximum sample rate of 100 kHz, 2 analog output (D/A) channels (12-bit), 8 digital input lines, and 8 digital output lines.

The Simulink Real-Time block library supports this board with these driver blocks:

- Diamond MM Analog Input (A/D)
- Diamond MM Analog Output (D/A)
- Diamond MM Digital Input
- Diamond MM Digital Output

Board Characteristics

Board name	Diamond-MM
Manufacturer	Diamond Systems Corporation
Bus type	PC/104
Access method	I/O mapped
Multiple block instance support	No
Multiple board support	Yes

External Websites

- www.diamondsystems.com

Diamond MM Analog Input (A/D)

MM Analog Input block

Library

Simulink Real-Time Library for Diamond

Scaling Input to Output

I/O Module Input	Block Output Data Type	Scaling
Volts	Double	1

Block Parameters

Number of channels

If you select 16 channels (**Coupling** parameter set to 16 single-ended channels) enter a number between 1 and 16 to select the number of single A/D channels used. If you select eight channels (**Coupling** parameter set to 8 differential channels) enter a number between 1 and 8.

Number the lines beginning with 1 even if this board manufacturer starts numbering the lines with 0.

Note, you cannot select the starting channel for this block, you can only select the number of channels. This block works differently from the Diamond-MM-32-AT A/D block, where you can specify the starting channel.

Range

Enter an input range code for the A/D channels. This driver does not allow the selection of a different range for each channel. The input range is the same for all A/D channels.

The following table is a list of the ranges for this driver and the corresponding range codes.

Input Range (V)	Range Code	Input Range (V)	Range Code
-10 to +10	-10	0 to +10	10
-5 to +5	-5	0 to +5	5
-2.5 to + 2.5	-2.5	0 to +2	2
-1 to +1	-1	0 to +1	1
-0.5 to +0.5	-5		

The gain jumpers on the board have to be set for the required range. The bipolar jumper on the board has to be in the bipolar position, if a bipolar range is used or in the unipolar position, when a unipolar range is used.

Coupling

From the list, select one from the following list of input modes:

- 16 single-ended channels
- 8 differential channels

This choice must correspond to the jumper setting in block J6 on the board.

Show error status output (E)

Select this check box to add a port labeled E to the block and to display (the contents of) that special port. This output has a value of 0 unless a problem is detected while attempting an A/D conversion. In the unlikely event that an error occurs, the port has a nonzero value. This nonzero value takes the form of a real number whose binary representation of 1's and 0's (true and false) indicates which channels have errors.

Sample time

Enter the base sample time or a multiple of the base sample time (- 1 means sample time is inherited).

Base address

Enter the base address of the board. This entry must correspond to the DIP switch setting on the board. For example, if the DIP switch setting is 300 (hexadecimal), enter 0x300.

External Websites

- www.diamondsystems.com

Diamond MM Analog Output (D/A)

MM Analog Output block

Library

Simulink Real-Time Library for Diamond

Scaling Input to Output

I/O Module Output	Block Input Data Type	Scaling
Volts	Double	1

Block Parameters

Channel vector

This parameter is a combined Channel vector and Range vector. The number of elements defines the number of D/A channels used.

Range vector

Enter a range code for each of the D/A channels used. This driver allows a different range for each channel with a maximum of 2 channels.

The following table is a list of the ranges for this driver and the corresponding range codes. The D/A specific jumpers on the board have to be set as required for the ranges entered.

Input Range (V)	Range Code
0 to +10	10
0 to +5	5

For example, if the first channel is 0 to + 10 volts and the second channel is 0 to +5 volts, enter

[10,5]

Reset vector

The reset vector controls the behavior of the channel at model termination. Enter a scalar or a vector that is the same length as the channel vector. If you specify a scalar value, that setting is replicated over the channel vector. If you specify a value of 1, the corresponding channel is reset to the value specified in the initial value vector. If you specify a value of 0, the channel remains at the last value attained while the model was running.

Initial value vector

The initial value vector contains the initial voltage values for the input channels. Enter a scalar or a vector that is the same length as the channel vector. If you specify a scalar value, that value is replicated as initial value over the channel vector. The channels are set to the initial values between the time the model is downloaded and the time it is started. If you provide an out-of-range value for a channel, that value is adjusted to be within the range defined by the parameter **Range**.

Sample time

Enter the base sample time or a multiple of the base sample time (- 1 means sample time is inherited).

Base address

Enter the base address of the board. This entry must correspond to the DIP switch setting on the board. For example, if the DIP switch setting is 300 (hexadecimal), enter 0x300.

External Websites

- www.diamondsystems.com

Diamond MM Digital Input

MM Digital Input block

Library

Simulink Real-Time Library for Diamond

Scaling Input to Output

I/O Module Input	Block Output Data Type	Scaling
TTL	Double	TTL low = 0.0 TTL high = 1.0

Block Parameters

Channel vector

Enter numbers between 1 and 8. This driver allows the selection of individual digital input channels in arbitrary order. The number of elements defines the number of digital input channels you use. For example, to use all the digital input channels, enter

[1:8]

Number the channels beginning with 1 even if this board manufacturer starts numbering the channels with 0.

Sample time

Enter the base sample time or a multiple of the base sample time (-1 means sample time is inherited).

Base address

Enter the base address of the board. This entry must correspond to the DIP switch setting on the board. For example, if the DIP switch setting is 300 (hexadecimal), enter 0x300.

External Websites

- www.diamondsystems.com

Diamond MM Digital Output

MM Digital Output block

Library

Simulink Real-Time Library for Diamond

Scaling Input to Output

I/O Module Output	Block Input Data Type	Scaling
TTL	Double	$< 0.5 = \text{TTL low}$ $\geq 0.5 = \text{TTL high}$

Block Parameters

Channel vector

Enter numbers between 1 and 8. This driver allows the selection of individual digital input channels in arbitrary order. The number of elements defines the number of digital input channels you use. For example, to use all the digital output channels, enter

```
[1:8]
```

Number the channels beginning with 1 even if this board manufacturer starts numbering the channels with 0.

Reset vector

The reset vector controls the behavior of the channel at model termination. Enter a scalar or a vector that is the same length as the channel vector. If you specify a scalar value, that setting is replicated over the channel vector. If you specify a value of 1, the corresponding channel is reset to the value specified in the initial value vector. If you specify a value of 0, the channel remains at the last value attained while the model was running.

Initial value vector

The initial value vector contains the initial voltage values for the input channels. Enter a scalar or a vector that is the same length as the channel vector. If you specify a scalar value, that value is replicated as initial value over the channel vector. The channels are set to the initial values between the time the model is downloaded and the time it is started. If you provide an out-of-range value for a channel, that value is adjusted to be within the range defined by the parameter **Range**.

Sample time

Enter the base sample time or a multiple of the base sample time (- 1 means sample time is inherited).

Base address

Enter the base address of the board. This entry must correspond to the DIP switch setting on the board. For example, if the DIP switch setting is 300 (hexadecimal), enter 0x300.

External Websites

- www.diamondsystems.com

Diamond Diamond-MM-16-AT

Diamond Diamond-MM-16-AT board

Board

Diamond Diamond-MM-16-AT

General Description

The Diamond MM-AT is a PC104 I/O board with 16 single-ended or 8 differential analog input (A/D) channels (16-bit), 4 optional analog output (D/A) channels (12-bit), 8 digital input and output lines. This board also supports autocalibration and an A/D FIFO.

Diamond-MM-16-AT boards have an 8-bit digital input port and an 8-bit digital output port.

The Simulink Real-Time block library supports this board with these driver blocks:

- Diamond MM-16-AT Analog Input (A/D)
- Diamond MM-16-AT Analog Output (D/A)
- Diamond MM-16-AT Digital Input
- Diamond MM-16-AT Digital Output

The Simulink Real-Time software does not support the counters/timers on this board.

Board Characteristics

Board name	Diamond-MM-16-AT
Manufacturer	Diamond Systems Corporation
Bus type	PC/104
Access method	I/O mapped
Multiple block instance support	No
Multiple board support	Yes

External Websites

- www.diamondsystems.com

Diamond MM-16-AT Analog Input (A/D)

MM-16-AT Analog Input block

Library

Simulink Real-Time Library for Diamond

Scaling Input to Output

I/O Module Input	Block Output Data Type	Scaling
Volts	Double	1

Block Parameters

First Channel

Enter the number of the first channel in a set of contiguous analog input channels. Depending on the channel configuration selected, the first channel number must be within the range 1 through 8 (**Coupling** parameter set to 8 differential channels) or 1 through 16 (**Coupling** parameter set to 16 single-ended channels).

Number the lines beginning with 1 even if this board manufacturer starts numbering the lines with 0.

Number of Channels

Enter the number of input channels you want to use. The maximum number of channels varies between 1 and 16 and depends on the values of **Coupling** and **First Channel**.

Range

From the list, choose a voltage range. The input range applies to all channels.

Coupling

From the list, select one from the following list of input modes:

- Single-ended (16 channels)
- Differential (8 channels)

This choice must correspond to the jumper setting in block J4 on the board.

Show error status output (E)

Select this check box to add a port labeled E to the block and to display (the contents of) that special port. This output has a value of 0 unless a problem is detected while attempting an A/D conversion. In the unlikely event that an error occurs, the port has a nonzero value. This nonzero value takes the form of a real number whose binary representation of 1's and 0's (true and false) indicates which channels have errors.

Sample time

Enter the base sample time or a multiple of the base sample time (- 1 means sample time is inherited).

Base address

Enter the base address of the board. This entry must correspond to the DIP switch setting on the board. For example, if the DIP switch setting is 300 (hexadecimal), enter 0x300.

External Websites

- www.diamondsystems.com

Diamond MM-16-AT Analog Output (D/A)

MM-16-AT Analog Output block

Library

Simulink Real-Time Library for Diamond

Scaling Input to Output

I/O Module Output	Block Output Data Type	Scaling
Volts	Double	1

Block Parameters

Channel vector

Enter numbers between 1 and 4. This driver allows the selection of individual D/A channels in arbitrary order. The number of elements defines the number of D/A channels you use. For example, to use the first and second analog output (D/A) channels, enter

[1,2]

Number the channels beginning with 1 even if this board manufacturer starts numbering the channels with 0.

Range

From the list, select 0 to 5V or -5V to 5V as the input voltage range of the board. The input range applies to all channels.

This choice must correspond to the jumper setting in block J5 on the board.

Reset vector

The reset vector controls the behavior of the channel at model termination. Enter a scalar or a vector that is the same length as the channel vector. If you specify a scalar value, that setting is replicated over the channel vector. If you specify a value of 1,

the corresponding channel is reset to the value specified in the initial value vector. If you specify a value of 0, the channel remains at the last value attained while the model was running.

Initial value vector

The initial value vector contains the initial voltage values for the input channels. Enter a scalar or a vector that is the same length as the channel vector. If you specify a scalar value, that value is replicated as initial value over the channel vector. The channels are set to the initial values between the time the model is downloaded and the time it is started. If you provide an out-of-range value for a channel, that value is adjusted to be within the range defined by the parameter **Range**.

Sample time

Enter the base sample time or a multiple of the base sample time (- 1 means sample time is inherited).

Base address

Enter the base address of the board. This entry must correspond to the DIP switch setting on the board. For example, if the DIP switch setting is 300 (hexadecimal), enter 0x300.

External Websites

- www.diamondsystems.com

Diamond MM-16-AT Digital Input

MM-16-AT Digital Input block

Library

Simulink Real-Time Library for Diamond

Scaling Input to Output

I/O Module Output	Block Output Data Type	Scaling
TTL	Double	TTL low = 0.0 TTL high = 1.0

Block Parameters

Channel vector

Enter numbers between 1 and 8. This driver allows the selection of individual digital input channels in arbitrary order. The number of elements defines the number of digital input channels you use. For example, to use all the digital input channels, enter

[1:8]

Number the channels beginning with 1 even if this board manufacturer starts numbering the channels with 0.

Sample time

Enter the base sample time or a multiple of the base sample time (-1 means sample time is inherited).

Base address

Enter the base address of the board. This entry must correspond to the DIP switch setting on the board. For example, if the DIP switch setting is 300 (hexadecimal), enter 0x300.

External Websites

- www.diamondsystems.com

Diamond MM-16-AT Digital Output

MM-16-AT Digital Output block

Library

Simulink Real-Time Library for Diamond

Scaling Input to Output

I/O Module Output	Block Output Data Type	Scaling
TTL	Double	TTL low = 0.0 TTL high = 1.0

Block Parameters

Channel vector

Enter numbers between 1 and 8. This driver allows the selection of individual digital output channels in arbitrary order. The number of elements defines the number of digital output channels you use. For example, to use all of the digital output channels, enter

[1:8]

Number the channels beginning with 1 even if this board manufacturer starts numbering the channels with 0.

Reset vector

The reset vector controls the behavior of the channel at model termination. Enter a scalar or a vector that is the same length as the channel vector. If you specify a scalar value, that setting is replicated over the channel vector. If you specify a value of 1, the corresponding channel is reset to the value specified in the initial value vector. If you specify a value of 0, the channel remains at the last value attained while the model was running.

Initial value vector

The initial value vector contains the initial voltage values for the output channels. Enter a scalar or a vector that is the same length as the channel vector. If you specify a scalar value, that value is replicated as initial value over the channel vector. The channels are set to the initial values between the time the model is downloaded and the time it is started. If you provide an out-of-range value for a channel, that value is adjusted to be within the range defined by the parameter **Range**.

Sample time

Enter the base sample time or a multiple of the base sample time (- 1 means sample time is inherited).

Base address

Enter the base address of the board. This entry must correspond to the DIP switch setting on the board. For example, if the DIP switch setting is 300 (hexadecimal), enter 0x300.

External Websites

- www.diamondsystems.com

Diamond Diamond-MM-32-AT

Diamond Diamond-MM-32-AT board

Board

Diamond Diamond-MM-32-AT

General Description

The Diamond-MM-32-AT is a PC104 I/O board with 32 single or 16 differential analog input (A/D) channels (16-bit) with a maximum sample rate of 200 kHz, 4 analog output (D/A) channels (12-bit), 24 digital input and output lines.

The Simulink Real-Time block library supports this board with these driver blocks. These blocks also support the Diamond-MM-32X-AT board.

- Diamond MM-32-AT Analog Input (A/D)
- Diamond MM-32-AT Frame Analog Input (A/D)
- Diamond MM-32-AT Analog Output (D/A)
- Diamond MM-32-AT Digital Input
- Diamond MM-32-AT Digital Output

Board Characteristics

Board name	Diamond-MM-32-AT
Manufacturer	Diamond Systems Corporation
Bus type	PC/104
Access method	I/O mapped
Multiple block instance support	A/D: No D/A: Yes DIO: Yes
Multiple board support	Yes

External Websites

- www.diamondsystems.com

Diamond MM-32-AT Analog Input (A/D)

MM-32-AT Analog Input block

Library

Simulink Real-Time Library for Diamond

Scaling Input to Output

I/O Module Input	Block Output Data Type	Scaling
Volts	Double	1

Block Parameters

Channel configuration

From the list, select the following. Refer to the Diamond-MM-32-AT documentation for a description of the configuration modes.

- **1-32 SE** to select the configuration mode labeled A (32 single-ended input channels)
- **1-16 DI** to select the configuration mode labeled B (16 differential input channels)
- **1-8SE 9-16 DI 17-24 SE** to select the configuration mode labeled D (eight single-ended input channels labeled 1 through 8, eight differential input channels labeled 9 through 16, and an additional eight single-ended input channels labeled 17 through 24).

Note that the selected channel configuration must match the configuration set by the jumpers in block J5. This driver does not support mode C.

First channel number

Enter the number of the first channel in a set of contiguous channels. Depending on the value of the **Channel Configuration** parameter, the first channel number must be within the range 1 through 32, 1 through 16, or 1 through 24.

Number of channels

Enter the number of input channels you want to use. The maximum number of channels varies between 1 and 32 and depends on **Channel configuration** and the **First channel number**.

Range

From the list, choose a voltage range. The input range applies to all channels.

Sample time

Enter the base sample time or a multiple of the base sample time (- 1 means sample time is inherited).

Base address

Enter the base address of the board. This entry must correspond to the DIP switch setting on the board. For example, if the DIP switch setting is 300 (hexadecimal), enter 0x300.

External Websites

- www.diamondsystems.com

Diamond MM-32-AT Frame Analog Input (A/D)

MM-32-AT Frame Analog Input block

Library

Simulink Real-Time Library for Diamond

Note

The Diamond-MM-32-AT Frame Analog Input block is a frame-based one. A frame consists of a fixed number of samples (defined by the **Number of scans per frame** parameter) for each of a specified set of channels. A scan is a group of samples, one for each channel.

Normally, the system timer controls a Simulink Real-Time model at intervals specified by the block **Sample Time** parameter. In contrast, the Diamond-MM-32-AT Frame Analog Input block executes the model in which it occurs each time it converts a new frame of data. You control this rate with the parameter values **Interval between scans** and **Number of scans per frame**:

$$\text{Rate} = (\text{Interval between scans}) \times (\text{Number of scans per frame})$$

You control the frame size with the parameter values **Number of channels** and **Number of scans per frame**:

$$\text{frameSize} = (\text{Number of channels}) \times (\text{Number of scans per frame})$$

After the block assembles a frame of data, it generates an interrupt, which triggers the next iteration of the model.

Note, after you add this block to a model and are ready to configure the model, edit the Simulink Real-Time code generation options.

- 1 From the model, select **Simulation > Model Configuration Parameters**.
- 2 Select the **Code Generation** node.
- 3 In the **Target selection** section, from the **System target file** list, browse to and select `slrt.tlc`.

- 4 In the **Simulink Real-Time Options** node, from the **I/O board generating the interrupt** list, select the value **Diamond-MM-32**. This specifies that the Diamond-MM-32-AT board generates the interrupt.
- 5 In the same node, from the **Real-time interrupt source** list, select the IRQ number you have jumpered on the board.
- 6 In the same node, for the **PCI slot (-1: autosearch) or ISA base address** parameter, enter the same ISA address as for the Diamond-MM-32-AT Frame block **Base address** parameter.
- 7 Click **OK** and save the model.

Note: To enable the interrupt for the frame-based block, the 16-bit bus jumper must be present in the board *J7* jumper block. For further details, see the section labeled "16-Bit Bus" in the Diamond-MM-32-AT documentation (www.diamondsystems.com).

Scaling Input to Output

I/O Module Input	Block Output Data Type	Scaling
Volts	Double	1

Block Parameters

Channel configuration

From the list, select the following. Refer to the Diamond-MM-32-AT documentation for a description of the configuration modes.

- **1-32 Single-Ended** to select the configuration mode labeled A (32 single-ended input channels)
- **1-16 Differential** to select the configuration mode labeled B (16 differential input channels)
- **1-8 and 7-24 Single-Ended; 9-16 Differential** to select the configuration mode labeled D (eight single-ended input channels labeled 1 through 8, eight differential input channels labeled 9 through 16, and an additional eight single-ended input channels labeled 17 through 24).

Note that the selected channel configuration must match the configuration set by the jumpers in block J5. This driver does not support mode C.

Output Signal Type

From the list, select either **Vector** or **Frame**:

- **Vector** — Select **Vector** if you expect the output signal from this block to be the input signal for a Simulink Real-Time scope or some other block that requires vector input.
- **Frame** — Select **Frame** if you expect the output signal from this block to be the input signal for a block that requires a frame. For example, a Signal Processing block.

Range

From the list, select a voltage range. The input range applies to all channels.

First channel number

Enter the number of the first channel in a set of contiguous channels. Depending on the value of the **Channel Configuration** parameter, the first channel number must be within the range 1 through 32, 1 through 16, or 1 through 24.

Number the channels starting from 1 even if Diamond Systems numbers them starting from 0.

Number of channels

Enter the number of input channels you want to use. The maximum number of channels varies between 1 and 32 and depends on **Channel configuration** and **First channel number**. Note that physical limitations require that either the **Number of channels** or **Number of scans per frame** value be even. If your model requires that both quantities be odd, add 1 to one of them and ignore the resulting additional data.

Number of scans per frame

Enter the number of scans per frame. For a value of N, each output port of the block will have a signal width of N and contain N samples of the corresponding channel. Note that physical limitations require that either the **Number of channels** or **Number of scans per frame** value be even. If your model requires that both quantities be odd, add 1 to one of them and ignore the resulting additional data.

Interval between conversions within a scan

From the list, select the interval, in microseconds, between conversions within a scan.

Interval between scans

Enter the interval, in seconds, between successive scans.

Base address

Enter the base address of the board. This entry must correspond to the DIP switch setting on the board. For example, if the DIP switch setting is 300 (hexadecimal), enter 0x300.

External Websites

- www.diamondsystems.com

Diamond MM-32-AT Analog Output (D/A)

MM-32-AT Analog Output block

Library

Simulink Real-Time Library for Diamond

Scaling Input to Output

I/O Module Output	Block Input Data Type	Scaling
Volts	Double	1

Block Parameters

Channel vector

Enter numbers between 1 and 4. This driver allows the selection of individual D/A channels in arbitrary order. The number of elements defines the number of D/A channels you use. For example, to use the first and second analog output (D/A) channels, enter

[1,2]

Number the channels beginning with 1 even if this board manufacturer starts numbering the channels with 0.

Range

From the list, choose a range code. This driver does not allow a different range for each of the four channels. This selection must correspond to the range and bipolar/unipolar jumper settings on the board.

The following table is a list of the ranges for this driver and the corresponding range codes. The D/A specific jumpers on the board must be set as required by the ranges entered.

Input Range (V)	Range Code
-10 to +10	-10
-5 to +5	-5
0 to +10	10
0 to +5	5

For example, if the first and second channel range is 0 to +10 volts, enter

[10,10]

Reset vector

The reset vector controls the behavior of the channel at model termination. Enter a scalar or a vector that is the same length as the channel vector. If you specify a scalar value, that setting is replicated over the channel vector. If you specify a value of 1, the corresponding channel is reset to the value specified in the initial value vector. If you specify a value of 0, the channel remains at the last value attained while the model was running.

Initial value vector

The initial value vector contains the initial voltage values for the output channels. Enter a scalar or a vector that is the same length as the channel vector. If you specify a scalar value, that value is replicated as the initial value over the channel vector. The channels are set to the initial values between the time the model is downloaded and the time it is started.

Sample time

Enter the base sample time or a multiple of the base sample time (-1 means sample time is inherited).

Base address

Enter the base address of the board. This entry must correspond to the DIP switch setting on the board. For example, if the DIP switch setting is 300 (hexadecimal), enter 0x300.

External Websites

- www.diamondsystems.com

Diamond MM-32-AT Digital Input

MM-32-AT Digital Input block

Library

Simulink Real-Time Library for Diamond

Note

The Diamond-MM-32-AT has one 8255 chip with three ports (A,B,C). Each port has a maximum of 8 digital I/O lines that can be configured as inputs or outputs.

Use a separate driver block for each port. By selecting the digital input driver block, you configure the port as input.

Scaling Input to Output

I/O Module Input	Block Output Data Type	Scaling
TTL	Double	TTL low = 0.0 TTL high = 1.0

Block Parameters

Channel vector

Enter numbers between 1 and 8 to select the digital input lines used with this port. This driver allows the selection of individual digital input lines in arbitrary order. The number of elements defines the number of digital lines used.

For example, to use all the digital inputs for one port, enter

```
[1,2,3,4,5,6,7,8]
```

Number the lines beginning with 1 even if this board manufacturer starts numbering the lines with 0.

Port

From the list choose **A**, **B**, or **C**. The I/O board has an 8255 chip with three ports. The **Port** parameter defines which port of the 8255 chip is used for this driver block. Each port has a maximum of eight digital lines that you can configure as inputs or outputs depending on which driver block is chosen. One block is required for each port used.

Sample time

Enter the base sample time or a multiple of the base sample time (- 1 means sample time is inherited).

Base address

Enter the base address of the board. This entry must correspond to the DIP switch setting on the board. For example, if the DIP switch setting is 300 (hexadecimal), enter **0x300**.

External Websites

- www.diamondsystems.com

Diamond MM-32-AT Digital Output

MM-32-AT Digital Output block

Library

Simulink Real-Time Library for Diamond

Note

The Diamond-MM-32-AT has one 8255 chip with three ports (A,B,C). Each port has a maximum of eight digital I/O lines that you can configure as inputs or outputs.

Use a separate driver block for each port. By selecting the digital output driver block, you can configure the port as output.

Scaling Input to Output

I/O Module Output	Block Input Data Type	Scaling
TTL	Double	$< 0.5 = \text{TTL low}$ $\geq 0.5 = \text{TTL high}$

Block Parameters

Channel vector

Enter numbers between 1 and 8 to select the digital output lines used with this port. This driver allows the selection of individual digital output lines in arbitrary order. The number of elements defines the number of digital lines used.

For example, to use all the digital outputs for one port, enter

[1,2,3,4,5,6,7,8]

Number the lines beginning with 1 even if this board manufacturer starts numbering the lines with 0.

Port

From the list choose either **A**, **B**, or **C**. The I/O board has an 8255 chip with three ports. The **Port** parameter defines which port of the 8255 chip is used for this driver block. Each port has a maximum of eight digital lines that can be configured as inputs or outputs depending on which driver block is chosen. One block is required for each port used.

Reset vector

The reset vector controls the behavior of the channel at model termination. Enter a scalar or a vector that is the same length as the channel vector. If you specify a scalar value, that setting is replicated over the channel vector. If you specify a value of 1, the corresponding channel is reset to the value specified in the initial value vector. If you specify a value of 0, the channel remains at the last value attained while the model was running.

Initial value vector

The initial value vector contains the initial values (0 or 1) of the output channels. Enter a scalar or a vector that is the same length as the channel vector. If you enter a scalar, that value is replicated as the initial value over the channel vector. The channels are set to these initial values between the time the model is downloaded and the time it is started.

Sample time

Enter the base sample time or a multiple of the base sample time (- 1 means sample time is inherited).

Base address

Enter the base address of the board. This entry must correspond to the DIP switch setting on the board. For example, if the DIP switch setting is 300 (hexadecimal), enter 0x300.

External Websites

- www.diamondsystems.com

Diamond Garnet-MM

Diamond Garnet-MM board

Board

Diamond Garnet-MM

General Description

The Garnet-MM is an I/O board with 24 or 48 high current digital I/O lines that can be configured in groups of eight for either digital input or digital output. There are two versions of this board, 24 (GMM-24) or 48 (GMM-48) digital I/O lines. The 48 line version has two 82C55 chips. Each chip has three 8-bit I/O ports for a total of 48 lines. The 24 line version has one 82C55 chip with three 8-bit I/O ports for a total of 24 lines.

The Simulink Real-Time block library supports this board with these driver blocks:

- Diamond Garnet-MM Digital Input
- Diamond Garnet-MM Digital Output

Board Characteristics

Board name	Garnet-MM
Manufacturer	Diamond Systems Corporation
Bus type	PC/104
Access method	I/O mapped
Multiple block instance support	DIO: Yes
Multiple board support	Yes

External Websites

- www.diamondsystems.com

Diamond Garnet-MM Digital Input

Garnet-MM Digital Input block

Library

Simulink Real-Time Library for Diamond

Note

Each chip port of the Garnet-MM board can be configured independently for either input or output. Use a separate driver block for each port. Select the digital output driver block for a given port to configure the port for output.

Scaling Input to Output

I/O Module Input	Block Output Data Type	Scaling
TTL	Double	TTL low = 0.0 TTL high = 1.0

Block Parameters

Channel vector

Enter numbers between 1 and 8 to select the digital input lines used with this port. This driver allows the selection of individual digital input lines in arbitrary order. The number of elements defines the number of digital lines used.

For example, to use all the digital inputs for the current port, enter

```
[ 1, 2, 3, 4, 5, 6, 7, 8 ]
```

Number the lines beginning with 1 even if this board manufacturer starts numbering the lines with 0.

Port

From the list choose A, B, or C.

Chip

From the list choose 1 or 2. Note, only select 1 for the 24 line version of the Garnet-MM board. Selecting 2 for the 24 line board does nothing. You can select either 1 or 2 for the 48 line version of the board.

Sample time

Enter the base sample time or a multiple of the base sample time (- 1 means sample time is inherited).

Base address

Enter the base address of the board. This entry must correspond to the DIP switch setting on the board. For example, if the DIP switch setting is 300 (hexadecimal), enter 0x300.

External Websites

- www.diamondsystems.com

Diamond Garnet-MM Digital Output

Garnet-MM Digital Output block

Library

Simulink Real-Time Library for Diamond

Note

Each chip port of the Garnet-MM board can be configured independently for either input or output. Use a separate driver block for each port. Select the digital input driver block for a given port to configure the port for input.

Scaling Input to Output

I/O Module Input	Block Output Data Type	Scaling
TTL	Double	TTL low = 0.0 TTL high = 1.0

Block Parameters

Channel vector

Enter numbers between 1 and 8 to select the digital output lines used with this port. This driver allows the selection of individual digital output lines in arbitrary order. The number of elements defines the number of digital lines used.

For example, to use all the digital outputs for the current port, enter

```
[ 1, 2, 3, 4, 5, 6, 7, 8 ]
```

Number the lines beginning with 1 even if this board manufacturer starts numbering the lines with 0.

Port

From the list choose A, B, or C.

Reset vector

The reset vector controls the behavior of the channel at model termination. Enter a scalar or a vector that is the same length as the channel vector. If you specify a scalar value, that setting is replicated over the channel vector. If you specify a value of 1, the corresponding channel is reset to the value specified in the initial value vector. If you specify a value of 0, the channel remains at the last value attained while the model was running.

Initial value vector

The initial value vector contains the initial values (0 or 1) of the output channels. Enter a scalar or a vector that is the same length as the channel vector. If you enter a scalar, that value is replicated as the initial value over the channel vector. The channels are set to these initial values between the time the model is downloaded and the time it is started.

Chip

From the list choose 1 or 2. Note, only select 1 for the 24 line version of the Garnet-MM board. Selecting 2 for the 24 line board does nothing. You can select either 1 or 2 for the 48 line version of the board.

Sample time

Enter the base sample time or a multiple of the base sample time (- 1 means sample time is inherited).

Base address

Enter the base address of the board. This entry must correspond to the DIP switch setting on the board. For example, if the DIP switch setting is 300 (hexadecimal), enter 0x300.

External Websites

- www.diamondsystems.com

Diamond Onyx-MM

Diamond Onyx-MM board

Board

Diamond Onyx-MM

General Description

The Onyx-MM is an I/O board with 48 digital I/O lines that can be configured in groups of eight for either input or output. The Simulink Real-Time software does not support the Counter/Timer functionality of this board.

The Simulink Real-Time block library supports this board with these driver blocks:

- Diamond Onyx-MM Digital Input
- Diamond Garnet-MM Digital Output

Board Characteristics

Board name	Onyx-MM
Manufacturer	Diamond Systems Corporation
Bus type	PC/104
Access method	I/O mapped
Multiple block instance support	DIO: Yes
Multiple board support	Yes

External Websites

- www.diamondsystems.com

Diamond Onyx-MM Digital Input

Onyx-MM Digital Input block

Library

Simulink Real-Time Library for Diamond

Note

Onyx-MM boards have two digital I/O chips, each with three 8-bit digital I/O ports, for a total of 48 I/O lines. Each port can be configured independently for either input or output. Use a separate driver block for each port. Select the digital input driver block for a given port to configure the port for input.

Scaling Input to Output

I/O Module Input	Block Output Data Type	Scaling
TTL	Double	TTL low = 0.0 TTL high = 1.0

Block Parameters

Channel vector

Enter numbers between 1 and 8 to select the digital input lines used with this port. This driver allows the selection of individual digital input lines in arbitrary order. The number of elements defines the number of digital lines used.

For example, to use all the digital inputs for the current port, enter

[1,2,3,4,5,6,7,8]

Number the lines beginning with 1 even if this board manufacturer starts numbering the lines with 0.

Port

From the list choose A, B, or C.

Chip

From the list choose 1 or 2.

Sample time

Enter the base sample time or a multiple of the base sample time (- 1 means sample time is inherited).

Base address

Enter the base address of the board. This entry must correspond to the DIP switch setting on the board. For example, if the DIP switch setting is 300 (hexadecimal), enter 0x300.

External Websites

- www.diamondsystems.com

Diamond Onyx-MM Digital Output

Onyx-MM Digital Output block

Library

Simulink Real-Time Library for Diamond

Note

Onyx-MM boards have two digital I/O chips, each with three 8-bit digital I/O ports, for a total of 48 I/O lines. Each port can be configured independently for either input or output. Use a separate driver block for each port. Select the digital output driver block for a given port to configure a port for output.

Scaling Input to Output

I/O Module Input	Block Output Data Type	Scaling
TTL	Double	TTL low = 0.0 TTL high = 1.0

Block Parameters

Channel vector

Enter numbers between 1 and 8 to select the digital output lines used with this port. This driver allows the selection of individual digital output lines in arbitrary order. The number of elements defines the number of digital lines used.

For example, to use all the digital outputs for the current port, enter

[1,2,3,4,5,6,7,8]

Number the lines beginning with 1 even if this board manufacturer starts numbering the lines with 0.

Port

From the list choose A, B, or C.

Reset vector

The reset vector controls the behavior of the channel at model termination. Enter a scalar or a vector that is the same length as the channel vector. If you specify a scalar value, that setting is replicated over the channel vector. If you specify a value of 1, the corresponding channel is reset to the value specified in the initial value vector. If you specify a value of 0, the channel remains at the last value attained while the model was running.

Initial value vector

The initial value vector contains the initial values (0 or 1) of the output channels. Enter a scalar or a vector that is the same length as the channel vector. If you enter a scalar, that value is replicated as the initial value over the channel vector. The channels are set to these initial values between the time the model is downloaded and the time it is started.

Chip

From the list choose 1 or 2.

Sample time

Enter the base sample time or a multiple of the base sample time (- 1 means sample time is inherited).

Base address

Enter the base address of the board. This entry must correspond to the DIP switch setting on the board. For example, if the DIP switch setting is 300 (hexadecimal), enter 0x300.

External Websites

- www.diamondsystems.com

Diamond Onyx-MM-DIO

Diamond Onyx-MM-DIO board

Board

Diamond Onyx-MM-DIO

General Description

The Onyx-MM is an I/O board with 48 digital I/O lines that can be configured in groups of eight for either digital input or digital output.

The Simulink Real-Time block library supports this board with these driver blocks:

- Diamond Onyx-MM Digital Input
- Diamond Onyx-MM Digital Output

Board Characteristics

Board name	Onyx-MM-DIO
Manufacturer	Diamond Systems Corporation
Bus type	PC/104
Access method	I/O mapped
Multiple block instance support	DIO: Yes
Multiple board support	Yes

External Websites

- www.diamondsystems.com

Diamond Onyx-MM-DIO Digital Input

Onyx-MM-DIO Digital Input block

Library

Simulink Real-Time Library for Diamond

Note

Onyx-MM-DIO boards have two digital I/O chips, each with three 8-bit digital I/O ports, for a total of 48 I/O lines. Each port can be configured independently for either input or output. Use a separate driver block for each port. Select the digital input driver block for a given port to configure the port for input.

Scaling Input to Output

I/O Module Input	Block Output Data Type	Scaling
TTL	Double	TTL low = 0.0 TTL high = 1.0

Block Parameters

Channel vector

Enter numbers between 1 and 8 to select the digital input lines used with this port. This driver allows the selection of individual digital input lines in arbitrary order. The number of elements defines the number of digital lines used.

For example, to use all the digital inputs for the current port, enter

```
[1,2,3,4,5,6,7,8]
```

Number the lines beginning with 1 even if this board manufacturer starts numbering the lines with 0.

Port

From the list choose A, B, or C.

Chip

From the list choose 1 or 2.

Sample time

Enter the base sample time or a multiple of the base sample time (- 1 means sample time is inherited).

Base address

Enter the base address of the board. This entry must correspond to the DIP switch setting on the board. For example, if the DIP switch setting is 300 (hexadecimal), enter 0x300.

External Websites

- www.diamondsystems.com

Diamond Onyx-MM-DIO Digital Output

Onyx-MM-DIO Digital Output block

Library

Simulink Real-Time Library for Diamond

Note

Onyx-MM-DIO boards have two digital I/O chips, each with three 8-bit digital I/O ports, for a total of 48 I/O lines. Each port can be configured independently for either input or output. Use a separate driver block for each port. Select the digital output driver block for a given port to configure a port for output.

Scaling Input to Output

I/O Module Input	Block Output Data Type	Scaling
TTL	Double	TTL low = 0.0 TTL high = 1.0

Block Parameters

Channel vector

Enter numbers between 1 and 8 to select the digital output lines used with this port. This driver allows the selection of individual digital output lines in arbitrary order. The number of elements defines the number of digital lines used.

For example, to use all the digital outputs for the current port, enter

[1,2,3,4,5,6,7,8]

Number the lines beginning with 1 even if this board manufacturer starts numbering the lines with 0.

Port

From the list choose A, B, or C.

Reset vector

The reset vector controls the behavior of the channel at model termination. Enter a scalar or a vector that is the same length as the channel vector. If you specify a scalar value, that setting is replicated over the channel vector. If you specify a value of 1, the corresponding channel is reset to the value specified in the initial value vector. If you specify a value of 0, the channel remains at the last value attained while the model was running.

Initial value vector

The initial value vector contains the initial values (0 or 1) of the output channels. Enter a scalar or a vector that is the same length as the channel vector. If you enter a scalar, that value is replicated as the initial value over the channel vector. The channels are set to these initial values between the time the model is downloaded and the time it is started.

Chip

From the list choose 1 or 2.

Sample time

Enter the base sample time or a multiple of the base sample time (- 1 means sample time is inherited).

Base address

Enter the base address of the board. This entry must correspond to the DIP switch setting on the board. For example, if the DIP switch setting is 300 (hexadecimal), enter 0x300.

External Websites

- www.diamondsystems.com

Diamond Prometheus, Athena, and Athena II

Diamond Prometheus, Athena, and Athena II boards

Board

Diamond Prometheus, Athena, Athena II

General Description

The Simulink Real-Time product supports the Diamond Prometheus, Athena, and Athena II boards.

- Diamond Prometheus — Intel 486-based embedded PC/104 CPU board with 4 serial ports, 2 USB ports, 1 parallel port, keyboard and mouse ports, floppy and IDE drive connectors, a 100BaseT Ethernet connector, and provision for solid-state flashdisk modules.

The Simulink Real-Time product supports Model PR-Z32-EA of Prometheus. In addition to the above functionality, Model PR-Z32-EA also contains a data acquisition subsystem. This subsystem supports 16 single-ended or 8 differential 16-bit A/D, 4 12-bit analog outputs, 24 programmable digital I/O channels, and a 16-bit counter/timer.

- Diamond Athena — Pentium III class VIA Eden processor-based embedded PC/104 CPU with 4 serial ports, 4 USB ports, 1 parallel port, keyboard and mouse ports, floppy and IDE drive connectors, a 100BaseT Ethernet connector, and a 16-bit data acquisition circuit.
- Diamond Athena II — Single board computer (SBC). Pentium III class VIA Mark CoreFusion™ processor based embedded PC/104 CPU with 4 serial ports, 4 USB ports, 1 parallel port, keyboard and mouse ports, floppy and IDE drive connectors, a 10/100 Mbps Ethernet connector, and a 16-bit data acquisition circuit.

The Simulink Real-Time block library supports the Prometheus Model PR-Z32-EA and Athena with four driver blocks:

- Diamond Prometheus/Athena/Athena II Analog Input (A/D)
- Diamond Prometheus/Athena/Athena II Analog Output (D/A)

- Diamond Prometheus/Athena/Athena II Digital Input
- Diamond Prometheus/Athena/Athena II Digital Output

The Simulink Real-Time software does not support the counter/timer on this board.

Board Characteristics

Board names	Prometheus, Athena, and Athena II
Manufacturer	Diamond Systems
Bus type	PC/104
Multiple block instance support	A/D: No, D/A: No, Digital I/O: Yes
Multiple board support	No

External Websites

- www.diamondsystems.com

Diamond Prometheus/Athena/Athena II Analog Input (A/D)

Prometheus/Athena Analog Input block

Library

Simulink Real-Time Library for Diamond

Scaling Input to Output

I/O Module Input	Block Output Data Type	Scaling
Volts	Double	1

Block Parameters

First channel

Enter the number of the first channel in a set of contiguous channels. Depending on the channel configuration selected, the first channel number must be within the range:

- 1 through 8, if the input coupling is differential
- 1 through 16, if the input coupling is single-ended

Number the channels beginning with 1 even if this board manufacturer starts numbering the channels with 0.

Number of channels

Enter the number of input channels you want to use. The maximum number of channels varies between 1 and 16 and depends on the values of **First channel** and **Input coupling (J13 setting)**. For example, if the value of **First channel** is 1 and **Input coupling (J13 setting)** is Single-ended, the maximum value for **Number of channels** is 16.

Range (J13 setting)

From the list, choose a voltage range. The input range applies to all channels. This range must agree with jumper settings in block J13 on the board.

Input coupling (J13 setting)

From the list, select one from the following list of input modes:

- Single-ended (16 channels)
- Differential (8 channels)

This choice must correspond to the jumper setting in block J13 on the board.

Show error status output port

Select this check box to display real-time error information. This check box displays an output port labeled E. As long as the driver does not detect an error on the channels currently in use, this signal has a value of 0. Values of 1, 2, 4, 8, and so forth respectively indicate problems on channels 1, 2, 3, 4, and so forth. To use one signal to indicate errors on multiple channels, the driver combines these values. For example, the E value $1 + 2 = 3$ encodes the concurrent errors on channels 1 and 2, the value $2 + 4 = 6$ encodes the concurrent errors on channels 2 and 3, and so on.

Sample time

Enter the base sample time or a multiple of the base sample time (- 1 means sample time is inherited).

Base address

Enter the base address of the board. This entry must correspond to the DIP switch setting on the board. For example, if the DIP switch setting is 300 (hexadecimal), enter 0x300.

External Websites

- www.diamondsystems.com

Diamond Prometheus/Athena/Athena II Analog Output (D/A)

Prometheus/Athena Analog Output block

Library

Simulink Real-Time Library for Diamond

Scaling Input to Output

I/O Module Output	Block Input Data Type	Scaling
Volts	Double	1

Block Parameters

Channel Vector

Enter a vector of numbers between 1 and 4. This driver allows the selection of individual D/A channels in arbitrary order. The number of elements defines the number of D/A channels used. For example, to use the first and second analog output (D/A) channels, enter

```
[1,2]
```

Number the channels beginning with 1 even if this board manufacturer starts numbering the channels with 0.

Range

From the list, choose a voltage range. The output range applies to all channels. This range must agree with jumper settings in block J13 on the board.

Reset vector

The reset vector controls the behavior of the channel at model termination. Enter a scalar or a vector that is the same length as the channel vector. If you specify a scalar value, that setting is replicated over the channel vector. If you specify a value of 1,

the corresponding channel is reset to the value specified in the initial value vector. If you specify a value of 0, the channel remains at the last value attained while the model was running.

Initial value vector

The initial value vector contains the initial voltage values for the output channels. Enter a scalar or a vector that is the same length as the channel vector. If you specify a scalar value, that value is replicated as initial value over the channel vector. The channels are set to the initial values between the time the model is downloaded and the time it is started.

If you provide an out-of-range value for a channel, that value is adjusted to be within the range defined by the parameter **Range**.

Show error status output port

Select this check box to display real-time error information. This check box displays an output port labeled E. As long as the driver does not detect an error on the channels currently in use, this signal has a value of 0. Values of 1, 2, 4, 8, and so forth respectively indicate problems on channels 1, 2, 3, 4, and so forth. To use one signal to indicate errors on multiple channels, the driver combines these values. For example, the E value $1 + 2 = 3$ encodes the concurrent errors on channels 1 and 2, the value $2 + 4 = 6$ encodes the concurrent errors on channels 2 and 3, and so on.

Sample time

Enter the base sample time or a multiple of the base sample time (- 1 means sample time is inherited).

Base address

Enter the base address of the board. This entry must correspond to the DIP switch setting on the board. For example, if the DIP switch setting is 300 (hexadecimal), enter 0x300.

External Websites

- www.diamondsystems.com

Diamond Prometheus/Athena/Athena II Digital Input

Prometheus/Athena Digital Input block

Library

Simulink Real-Time Library for Diamond

Note

Prometheus and Athena boards have three I/O ports, each containing eight digital I/O lines. You can independently configure these ports for either input or output. Use a separate driver block for each port. By selecting the digital input driver block for a given port, that port is configured for input.

Scaling Input to Output

I/O Module Input	Block Output Data Type	Scaling
TTL	Double	TTL low = 0.0 TTL high = 1.0

Block Parameters

Channel Vector

Enter a vector of numbers between 1 and 8 to select the digital input lines used from this port. This driver allows the selection of individual digital input lines in arbitrary order. The number of elements defines the number of digital lines used. For example, to use all of the digital inputs for the current port, enter

[1:8]

Number the lines starting with 1 even if this board manufacturer starts numbering them with 0.

Port

From the list, choose A, B, or C to choose one of the three I/O ports.

Sample time

Enter the base sample time or a multiple of the base sample time (- 1 means sample time is inherited).

Base address

Enter the base address of the board. This entry must correspond to the DIP switch setting on the board. For example, if the DIP switch setting is 300 (hexadecimal), enter 0x300.

External Websites

- www.diamondsystems.com

Diamond Prometheus/Athena/Athena II Digital Output

Prometheus/Athena Digital Output block

Library

Simulink Real-Time Library for Diamond

Note

Prometheus and Athena boards have three I/O ports, each containing eight digital I/O lines. You can independently configure these ports for either input or output. Use a separate driver block for each port. By selecting the digital output driver block for a given port, that port is configured for output.

Scaling Input to Output

I/O Module Input	Block Output Data Type	Scaling
TTL	Double	TTL low = 0.0 TTL high = 1.0

Block Parameters

Channel Vector

Enter a vector of numbers between 1 and 8 to select the digital output lines used from this port. This driver allows the selection of individual digital output lines in arbitrary order. The number of elements defines the number of digital lines used. For example, to use all of the digital outputs for the current port, enter

[1:8]

Number the lines starting with 1 even if this board manufacturer starts numbering them with 0.

Port

From the list, choose A, B, or C to choose one of the three I/O ports.

Reset vector

The reset vector controls the behavior of the channel at model termination. Enter a scalar or a vector that is the same length as the channel vector. If you specify a scalar value, that setting is replicated over the channel vector. If you specify a value of 1, the corresponding channel is reset to the value specified in the initial value vector. If you specify a value of 0, the channel remains at the last value attained while the model was running.

Initial value vector

The initial value vector contains the initial voltage values for the output channels. Enter a scalar or a vector that is the same length as the channel vector. If you specify a scalar value, that value is replicated as the initial value over the channel vector. The channels are set to the initial values between the time the model is downloaded and the time it is started.

Sample time

Enter the base sample time or a multiple of the base sample time (- 1 means sample time is inherited).

Base address

Enter the base address of the board. This entry must correspond to the DIP switch setting on the board. For example, if the DIP switch setting is 300 (hexadecimal), enter 0x300.

External Websites

- www.diamondsystems.com

Diamond Quartz-MM-10

Diamond Quartz-MM-10 board

Board

Diamond Quartz-MM-10

General Description

The Quartz-MM 10 has eight digital input line and eight digital output lines.

The Simulink Real-Time block library supports this board with these driver blocks:

- Diamond Quartz-MM-10 Digital Input
- Diamond Quartz-MM-10 Digital Output

Board Characteristics

Board name	Quartz-MM-10
Manufacturer	Diamond Systems Corporation
Bus type	PC/104
Access method	I/O mapped
Multiple block instance support	Yes — a channel can be accessed by at most one block
Multiple board support	Yes

External Websites

- www.diamondsystems.com

Diamond Quartz-MM-10 Digital Input

Quartz-MM-10 Digital Input block

Library

Simulink Real-Time Library for Diamond

Scaling Input to Output

I/O Module Input	Block Output Data Type	Scaling
TTL	Double	TTL low = 0.0 TTL high = 1.0

Block Parameters

Channel vector

Enter numbers between 1 and 8 to select the digital input lines used with this port. This driver allows the selection of individual digital input lines in arbitrary order. The number of elements defines the number of digital lines used.

For example, to use all the digital inputs for one port, enter

```
[ 1, 2, 3, 4, 5, 6, 7, 8 ]
```

Number the lines beginning with 1 even if this board manufacturer starts numbering the lines with 0.

Sample time

Enter the base sample time or a multiple of the base sample time (- 1 means sample time is inherited).

Base address

Enter the base address of the board. This entry must correspond to the DIP switch setting on the board. For example, if the DIP switch setting is 300 (hexadecimal), enter 0x300.

External Websites

- www.diamondsystems.com

Diamond Quartz-MM-10 Digital Output

Quartz-MM-10 Digital Output block

Library

Simulink Real-Time Library for Diamond

Scaling Input to Output

I/O Module Output	Block Input Data Type	Scaling
TTL	Double	$< 0.5 = \text{TTL low}$ $\geq 0.5 = \text{TTL high}$

Block Parameters

Channel vector

Enter numbers between 1 and 8 to select the digital input lines used with this port. This driver allows the selection of individual digital input lines in arbitrary order. The number of elements defines the number of digital lines used.

For example, to use all the digital inputs for one port, enter

```
[ 1, 2, 3, 4, 5, 6, 7, 8 ]
```

Number the lines beginning with 1 even if this board manufacturer starts numbering the lines with 0.

Sample time

Enter the base sample time or a multiple of the base sample time (- 1 means sample time is inherited).

Base address

Enter the base address of the board. This entry must correspond to the DIP switch setting on the board. For example, if the DIP switch setting is 300 (hexadecimal), enter 0x300.

External Websites

- www.diamondsystems.com

Diamond Quartz-MM-5

Diamond Quartz-MM-5 board

Board

Diamond Quartz-MM-5

General Description

The Quartz-MM 5 has 8 digital input lines, 8 digital output lines.

The Simulink Real-Time block library supports this board with these driver blocks:

- Diamond Quartz-MM-5 Digital Input
- Diamond Quartz-MM-5 Digital Output

Board Characteristics

Board name	Quartz-MM-5
Manufacturer	Diamond Systems Corporation
Bus type	PC/104
Access method	I/O mapped
Multiple block instance support	Yes — a channel can be accessed by at most one block
Multiple board support	Yes

External Websites

- www.diamondsystems.com

Diamond Quartz-MM-5 Digital Input

Quartz-MM-5 Digital Input block

Library

Simulink Real-Time Library for Diamond

Scaling Input to Output

I/O Module Input	Block Output Data Type	Scaling
TTL	Double	TTL low = 0.0 TTL high = 1.0

Block Parameters

Channel vector

Enter numbers between 1 and 8 to select the digital input lines used with this port. This driver allows the selection of individual digital input lines in arbitrary order. The number of elements defines the number of digital lines used.

For example, to use all of the digital inputs for one port, enter

```
[ 1, 2, 3, 4, 5, 6, 7, 8 ]
```

Number the lines beginning with 1 even if this board manufacturer starts numbering the lines with 0.

Sample time

Enter the base sample time or a multiple of the base sample time (- 1 means sample time is inherited).

Base address

Enter the base address of the board. This entry must correspond to the DIP switch setting on the board. For example, if the DIP switch setting is 300 (hexadecimal), enter 0x300.

External Websites

- www.diamondsystems.com

Diamond Quartz-MM-5 Digital Output

Quartz-MM-5 Digital Output block

Library

Simulink Real-Time Library for Diamond

Scaling Input to Output

I/O Module Output	Block Input Data Type	Scaling
TTL	Double	$< 0.5 = \text{TTL low}$ $\geq 0.5 = \text{TTL high}$

Block Parameters

Channel vector

Enter numbers between 1 and 8 to select the digital input lines used with this port. This driver allows the selection of individual digital input lines in arbitrary order. The number of elements defines the number of digital lines used.

For example, to use all of the digital inputs for one port, enter

```
[ 1, 2, 3, 4, 5, 6, 7, 8 ]
```

Number the lines beginning with 1 even if this board manufacturer starts numbering the lines with 0.

Sample time

Enter the base sample time or a multiple of the base sample time (- 1 means sample time is inherited).

Base address

Enter the base address of the board. This entry must correspond to the DIP switch setting on the board. For example, if the DIP switch setting is 300 (hexadecimal), enter 0x300.

External Websites

- www.diamondsystems.com

Diamond Ruby-MM

Diamond Ruby-MM board

Board

Diamond Ruby-MM

General Description

The Diamond Ruby-MM is a PC104 I/O board with 4 or 8 single analog output (D/A) channels (12-bit), unipolar and bipolar operation, $\pm 10V$, $\pm 5V$, 0-10V, 0-5V fixed ranges, $\pm 2.5V$, 0-2.5V user-adjustable ranges, 24 digital input and output lines.

The Simulink Real-Time block library supports this board with these driver blocks:

- Diamond Ruby-MM Analog Output (D/A)
- Diamond Ruby-MM Digital Input
- Diamond Ruby-MM Digital Output

Board Characteristics

Board name	Diamond Ruby-MM
Manufacturer	Diamond Systems Corporation
Bus type	PC/104
Access method	I/O Mapped
Multiple block instance support	D/A: No, DIO: Yes
Multiple board support	Yes

External Websites

- www.diamondsystems.com

Diamond Ruby-MM Analog Output (D/A)

Ruby-MM Analog Output block

Library

Simulink Real-Time Library for Diamond

Scaling Input to Output

I/O Module Output	Block Input Data Type	Scaling
Volts	Double	1

Block Parameters

Channel vector

List the output channels as a vector. Up to 8 different channels can be listed. To specify the first three channels, enter

```
[1,2,3]
```

The board comes in two different versions. If you use the 4-channel version and include channels 5-8, the those outputs will not show an error, but the data will be ignored.

Range

The output range of the board is selected with jumpers on the board. Each group of 4 channels can be jumpered for the available ranges. The range you select in the Block Parameters must correspond to the range specified by the jumper settings or you will obtain unexpected results.

Reset vector

The reset vector controls the behavior of the channel at model termination. Enter a scalar or a vector that is the same length as the channel vector. If you specify a scalar value, that setting is replicated over the channel vector. If you specify a value of 1, the corresponding channel is reset to the value specified in the initial value vector.

If you specify a value of 0, the channel remains at the last value attained while the model was running.

Initial value vector

The initial value vector contains the initial voltage values for the output channels. Enter a scalar or a vector that is the same length as the channel vector. If you specify a scalar value, that value is replicated as the initial value over the channel vector. The channels are set to the initial values between the time the model is downloaded and the time it is started.

Sample time

Enter the base sample time or a multiple of the base sample time (- 1 means sample time is inherited).

Base address

Enter the base address of the board. This entry must correspond to the DIP switch setting on the board. For example, if the DIP switch setting is 300 (hexadecimal), enter 0x300.

Note: Please consult the Diamond Ruby-MM manufacturer documentation for more information on jumper settings and I/O connections.

External Websites

- www.diamondsystems.com

Diamond Ruby-MM Digital Input

Ruby-MM Digital Input block

Scaling Input to Output

I/O Module Input	Block Output Data Type	Scaling
TTL	Double	TTL low = 0.0 TTL high = 1.0

Block Parameters

Channel vector

Enter numbers between 1 and 8 to select the digital input lines to be read. This driver allows the selection of up to 8 individual digital input lines in arbitrary order. The number of elements defines the number of digital lines used.

For example, to use all of the digital inputs enter

```
[1,2,3,4,5,6,7,8]
```

Number the lines beginning with 1 even if this board manufacturer starts numbering lines with 0.

Port

From the **Port** list, choose either **A**, **B**, or **C**. The **Port** parameter defines which port is used for this driver block. Each port has a maximum of 8 digital inputs. One block is required for each port used.

Sample time

Enter the base sample time or a multiple of the base sample time (- 1 means sample time is inherited).

Base address

Enter the base address of the board. This entry must correspond to the DIP switch setting on the board. For example, if the DIP switch setting is 300 (hexadecimal), enter **0x300**.

Note: Please consult the Diamond Ruby-MM manufacturer documentation for more information on jumper settings and I/O connections.

External Websites

- www.diamondsystems.com

Diamond Ruby-MM Digital Output

Ruby-MM Digital Output block

Library

Simulink Real-Time Library for Diamond

Scaling Input to Output

I/O Module Output	Block Input Data Type	Scaling
TTL	Double	$< 0.5 = \text{TTL low}$ $\geq 0.5 = \text{TTL high}$

Block Parameters

Channel vector

Enter numbers between 1 and 8 to select the digital output lines to drive. This driver allows the selection of up to 8 individual digital output lines in arbitrary order. The number of elements defines the number of digital lines used.

For example, to use all of the digital inputs enter

```
[1,2,3,4,5,6,7,8]
```

Number the lines beginning with 1 even if this board manufacturer starts numbering lines with 0.

Port

From the **Port** list, choose either **A**, **B**, or **C**. The **Port** parameter defines which port is used for this driver block. Each port has a maximum of 8 digital outputs. One block is required for each port used.

Reset vector

The reset vector controls the behavior of the channel at model termination. Enter a scalar or a vector that is the same length as the channel vector. If you specify a scalar

value, that setting is replicated over the channel vector. If you specify a value of 1, the corresponding channel is reset to the value specified in the initial value vector. If you specify a value of 0, the channel remains at the last value attained while the model was running.

Initial value vector

The initial value vector contains the initial values (0 or 1) of the output channels. Enter a scalar or a vector that is the same length as the channel vector. If you enter a scalar, that value is replicated as the initial value over the channel vector. The channels are set to these initial values between the time the model is downloaded and the time it is started.

Sample time

Enter the base sample time or a multiple of the base sample time (- 1 means sample time is inherited).

Base address

Enter the base address of the board. This entry must correspond to the DIP switch setting on the board. For example, if the DIP switch setting is 300 (hexadecimal), enter 0x300.

Note: Please consult the Diamond Ruby-MM manufacturer documentation for more information on jumper settings and I/O connections.

External Websites

- www.diamondsystems.com

Diamond Ruby-MM-416

Diamond Ruby-MM-416 board

Board

Diamond Ruby-MM-416

General Description

The Ruby-MM-416 is an I/O board with four 16-bit analog output (D/A) channels, and 24 digital I/O lines that can be configured in groups of eight for either input or output.

The Simulink Real-Time block library supports this board with these driver blocks:

- Diamond Ruby-MM-416 Analog Output (D/A)
- Diamond Ruby-MM-416 Digital Input
- Diamond Ruby-MM-416 Digital Output

Board Characteristics

Board name	Ruby-MM-416
Manufacturer	Diamond Systems Corporation
Bus type	PCI/104
Access method	I/O Mapped
Multiple block instance support	D/A: No DIO: Yes
Multiple board support	Yes

External Websites

- www.diamondsystems.com

Diamond Ruby-MM-416 Analog Output (D/A)

Ruby-MM-416 Analog Output block

Library

Simulink Real-Time Library for Diamond

Scaling Input to Output

I/O Module Output	Block Input Data Type	Scaling
Volts	Double	1

Block Parameters

Channel vector

Enter a vector containing channel numbers between 1 and 4. This driver allows the selection of individual D/A channels in arbitrary order. The number of elements defines the number of D/A channels used. For example, to use the first and second analog output (D/A) channels, enter

[1,2]

Number the channels beginning with 1 even if this board manufacturer starts numbering the channels with 0.

Range vector

The range vector must be a scalar or a vector the same length as the channel vector. The vector entries must use range codes from the following table

Input Range (V)	Range Code
-10 to +10	-10
-5 to +5	-5
0 to 10	10

The range codes you enter must be consistent with the jumper settings on the board.

Reset vector

The reset vector controls the behavior of the channel at model termination. Enter a scalar or a vector that is the same length as the channel vector. If you specify a scalar value, that setting is replicated over the channel vector. If you specify a value of 1, the corresponding channel is reset to the value specified in the initial value vector. If you specify a value of 0, the channel remains at the last value attained while the model was running.

Initial value vector

The initial value vector contains the initial voltage values for the output channels. Enter a scalar or a vector that is the same length as the channel vector. If you specify a scalar value, that value is replicated as initial value over the channel vector. The channels are set to the initial values between the time the model is downloaded and the time it is started. If you provide a value that is out of the channel's range, the value is reset to the lower or upper range value.

Sample time

Enter the base sample time or a multiple of the base sample time (- 1 means sample time is inherited).

Base address

Enter the base address of the board. This entry must correspond to the DIP switch setting on the board. For example, if the DIP switch setting is 300 (hexadecimal), enter 0x300.

External Websites

- www.diamondsystems.com

Diamond Ruby-MM-416 Digital Input

Ruby-MM-416 Digital Input block

Library

Simulink Real-Time Library for Diamond

Note

Ruby-MM-416 boards have three I/O ports, each containing eight digital I/O lines. These ports can be configured independently for either input or output. Use a separate driver block for each port. By selecting the digital input driver block for a given port, you configure that port for input.

Scaling Input to Output

I/O Module Input	Block Output Data Type	Scaling
TTL	Double	TTL low = 0.0 TTL high = 1.0

Block Parameters

Channel vector

Enter numbers between 1 and 8 to select the digital input lines used with this port. This driver allows the selection of individual digital input lines in arbitrary order. The number of elements defines the number of digital lines used.

For example, to use all the digital inputs for the current port, enter

```
[1,2,3,4,5,6,7,8]
```

Number the lines beginning with 1 even if this board manufacturer starts numbering the lines with 0.

Port

From the list choose A, B, or C.

Sample time

Enter the base sample time or a multiple of the base sample time (- 1 means sample time is inherited).

Base address

Enter the base address of the board. This entry must correspond to the DIP switch setting on the board. For example, if the DIP switch setting is 300 (hexadecimal), enter 0x300.

External Websites

- www.diamondsystems.com

Diamond Ruby-MM-416 Digital Output

Ruby-MM-416 Digital Output block

Library

Simulink Real-Time Library for Diamond

Note

Ruby-MM-416 boards have three I/O ports, each containing eight digital I/O lines. These ports can be configured independently for either input or output. Use a separate driver block for each port. By selecting the digital input driver block for a given port, that port is configured for input.

Scaling Input to Output

I/O Module Input	Block Output Data Type	Scaling
TTL	Double	TTL low = 0.0 TTL high = 1.0

Block Parameters

Channel vector

Enter numbers between 1 and 8 to select the digital output lines used with this port. This driver allows the selection of individual digital output lines in arbitrary order. The number of elements defines the number of digital lines used.

For example, to use all the digital outputs for the current port, enter

```
[1,2,3,4,5,6,7,8]
```

Number the lines beginning with 1 even if this board manufacturer starts numbering the lines with 0.

Port

From the list choose A, B, or C.

Sample time

Enter the base sample time or a multiple of the base sample time (- 1 means sample time is inherited).

Base address

Enter the base address of the board. This entry must correspond to the DIP switch setting on the board. For example, if the DIP switch setting is 300 (hexadecimal), enter 0x300.

External Websites

- www.diamondsystems.com

Diamond Ruby-MM-1612

Diamond Ruby-MM-1612 board

Board

Diamond Ruby-MM-1612

General Description

The Ruby-MM-1612 is an I/O board with 16 (12-bit) analog output (D/A) channels, and 24 digital I/O lines that can be configured in groups of eight for either input or output.

The Simulink Real-Time block library supports this board with these driver blocks:

- Diamond Ruby-MM-1612 Analog Output (D/A)
- Diamond Ruby-MM-1612 Digital Input
- Diamond Ruby-MM-1612 Digital Output

Board Characteristics

Board name	Ruby-MM-1612
Manufacturer	Diamond Systems Corporation
Bus type	PC/104
Access method	I/O Mapped
Multiple block instance support	D/A: No DIO: Yes
Multiple board support	Yes

External Websites

- www.diamondsystems.com

Diamond Ruby-MM-1612 Analog Output (D/A)

Ruby-MM-1612 Analog Output block

Library

Simulink Real-Time Library for Diamond

Scaling Input to Output

I/O Module Output	Block Input Data Type	Scaling
Volts	Double	1

Block Parameters

Channel vector

Enter a vector containing channel numbers between 1 and 16. This driver allows the selection of individual D/A channels in arbitrary order. The number of elements defines the number of D/A channels used. For example, to use the first and second analog output (D/A) channels, enter

```
[1,2]
```

Number the channels beginning with 1 even if this board manufacturer starts numbering the channels with 0.

Range for bank 1, Range for bank 2

Bank 1 consists of channels 1 to 8 and bank 2 consists of channels 9 to 16. The output range may be specified on a per-bank basis. These ranges must correspond to the jumper settings in header R4 on the board. See the board manual for details.

If you select a range of either -5V to +5V or 0 to +5V for one bank, then it is not possible to select a range of either -10V to +10V or 0 to +10V for the other bank. This is because jumper 5 in header J4 (On-Board Reference Full-Scale Voltage Selection) affects all channels, not just those of a single bank. See the board manual

for details. The table lists the allowed output voltage range combinations for the two channel banks. Column B1 is the first bank of channels, column B2 is the second bank of channels.

B1	B2	Configuration
±10 V	±10 V	C11
0-10 V	±10 V	C41
±5 V	±5 V	C22
±2.5	±5 V	C32
0-5 V	±5 V	C52
0-2.5 V	±5 V	C62
±5 V	±2.5 V	C23
±2.5 V	±2.5 V	C33
0-5 V	±2.5 V	C53
0-2.5 V	±2.5 V	C63
±10 V	0-10 V	C14
0-10 V	0-10 V	C44
±5 V	0-5 V	C25
±2.5 V	0-5 V	C35
0-5 V	0-5 V	C55
0-2.5 V	0-5 V	C65
±5 V	0-2.5 V	C26
±2.5 V	0-2.5 V	C36
0-5 V	0-2.5 V	C56
0-2.5 V	0-2.5 V	C66

This driver supports the Adjustable Reference Voltage. You can use this feature with either output range -2.5V to +2.5V or 0 to +2.5V. If for example you adjust potentiometer R4 to 2.3 V (instead of the default setting of 2.5), then an input signal of 1.2 results in an output voltage of $(1.2 / 2.5) * 2.3 \text{ V} = 1.1 \text{ V}$. See the board manual for details.

Reset vector

The reset vector controls the behavior of the channel at model termination. Enter a scalar or a vector that is the same length as the channel vector. If you specify a scalar value, that setting is replicated over the channel vector. If you specify a value of 1, the corresponding channel is reset to the value specified in the initial value vector. If you specify a value of 0, the channel remains at the last value attained while the model was running.

Initial value vector

The initial value vector contains the initial voltage values for the output channels. Enter a scalar or a vector that is the same length as the channel vector. If you specify a scalar value, that value is replicated as initial value over the channel vector. The channels are set to the initial values between the time the model is downloaded and the time it is started. If you provide a value that is out of the channel's range, the value is reset to the lower or upper range value.

Sample time

Enter the base sample time or a multiple of the base sample time (- 1 means sample time is inherited).

Base address

Enter the base address of the board. This entry must correspond to the DIP switch setting on the board. For example, if the DIP switch setting is 300 (hexadecimal), enter 0x300.

External Websites

- www.diamondsystems.com

Diamond Ruby-MM-1612 Digital Input

Ruby-MM-1612 Digital Input block

Library

Simulink Real-Time Library for Diamond

Note

Ruby-MM-1612 boards have three I/O ports, each containing eight digital I/O lines. These ports can be configured independently for either input or output. Use a separate driver block for each port. By selecting the digital input driver block for a given port, that port is configured for input.

Scaling Input to Output

I/O Module Input	Block Output Data Type	Scaling
TTL	Double	TTL low = 0.0 TTL high = 1.0

Block Parameters

Channel vector

Enter numbers between 1 and 8 to select the digital input lines used with this port. This driver allows the selection of individual digital input lines in arbitrary order. The number of elements defines the number of digital lines used.

For example, to use all the digital inputs for the current port, enter

```
[1,2,3,4,5,6,7,8]
```

Number the lines beginning with 1 even if this board manufacturer starts numbering the lines with 0.

Port

From the list choose A, B, or C.

Sample time

Enter the base sample time or a multiple of the base sample time (- 1 means sample time is inherited).

Base address

Enter the base address of the board. This entry must correspond to the DIP switch setting on the board. For example, if the DIP switch setting is 300 (hexadecimal), enter 0x300.

External Websites

- www.diamondsystems.com

Diamond Ruby-MM-1612 Digital Output

Ruby-MM-1612 Digital Output block

Library

Simulink Real-Time Library for Diamond

Note

Ruby-MM-1612 series boards have three I/O ports, each containing eight digital I/O lines. These ports can be configured independently for either input or output. Use a separate driver block for each port. By selecting the digital output driver block for a given port, you configure that port for output.

Scaling Input to Output

I/O Module Input	Block Output Data Type	Scaling
TTL	Double	TTL low = 0.0 TTL high = 1.0

Block Parameters

Channel vector

Enter numbers between 1 and 8 to select the digital output lines used with this port. This driver allows the selection of individual digital output lines in arbitrary order. The number of elements defines the number of digital lines used.

For example, to use all the digital outputs for the current port, enter

```
[1,2,3,4,5,6,7,8]
```

Number the lines beginning with 1 even if this board manufacturer starts numbering the lines with 0.

Port

From the list choose A, B, or C.

Reset vector

The reset vector controls the behavior of the channel at model termination. Enter a scalar or a vector that is the same length as the channel vector. If you specify a scalar value, that setting is replicated over the channel vector. If you specify a value of 1, the corresponding channel is reset to the value specified in the initial value vector. If you specify a value of 0, the channel remains at the last value attained while the model was running.

Initial value vector

The initial value vector contains the initial voltage values for the output channels. Enter a scalar or a vector that is the same length as the channel vector. If you specify a scalar value, that value is replicated as initial value over the channel vector. The channels are set to the initial values between the time the model is downloaded and the time it is started. If you provide a value that is out of the channel's range, the value is reset to the lower or upper range value.

Sample time

Enter the base sample time or a multiple of the base sample time (- 1 means sample time is inherited).

Base address

Enter the base address of the board. This entry must correspond to the DIP switch setting on the board. For example, if the DIP switch setting is 300 (hexadecimal), enter 0x300.

External Websites

- www.diamondsystems.com

Model-Based FlexRay Communications Support

- “Install FlexRay Network and Configuration Software” on page 35-2
- “FlexRay Installation and Setup Requirements” on page 35-3
- “Configure FlexRay Node for Signal Access” on page 35-4
- “Prepare FlexRay Network for Signal Access” on page 35-15
- “Prepare FlexRay Model for Signal Access” on page 35-16
- “Configure FlexRay Node for PDU Access” on page 35-29
- “Prepare FlexRay Network for PDU Access” on page 35-39
- “Prepare FlexRay Model for PDU Access” on page 35-40
- “Configure FlexRay Node for Error Injection” on page 35-57
- “Prepare FlexRay Network for Error Injection” on page 35-66
- “Prepare FlexRay Model for Error Injection” on page 35-67
- “Evaluate Clear from Bus Preconditions” on page 35-84
- “FlexRay Troubleshooting” on page 35-86

Install FlexRay Network and Configuration Software

To install FlexRay network and configuration software, verify that your development and target computers meet the installation requirements. See “FlexRay Installation and Setup Requirements” on page 35-3.

- 1 Install the EB tresos Busmirror configuration software on the development computer according to the manufacturer instructions (www.elektrobit.com).
- 2 Install the required FlexRay cards in the target computer according to the manufacturer instructions.
- 3 To determine the PCI bus and slot for the FlexRay cards, in the Command Window, type:

```
slrtpingtarget
tg=slrt;
getPCIInfo(tg, 'installed')
```

Record the Bus and Slot numbers for each Elektrobit EB5100 card in the target computer.

External Websites

- www.elektrobit.com

FlexRay Installation and Setup Requirements

Before you install the FlexRay network and software, verify the installation requirements.

To install the required FlexRay boards, the target computer must be a PCI bus computer with the required free slots.

To install the EB tresos Busmirror software and libraries, the development computer must meet the following requirements:

- PC compatible workstation with Windows XP SP2/SP3 or Windows 7 installed.
- If the software is using the USB dongle license, a free USB port.
- If the software is using a network license server, an Ethernet connection.
- 800 MB of free disk space.
- 512 MB RAM.
- If you are installing from a CD, a CD ROM drive.
- If you are installing from Download Area EB Austria, an internet connection.

Acquire the workstation, the FlexRay boards, the EB tresos Busmirror software and libraries, and the required licenses from Speedgoat. See “Speedgoat Target Computer Configuration”.

Configure FlexRay Node for Signal Access

In this section...

“Create Busmirror Project for Signal Access” on page 35-4

“Select FlexRay Node for Signal Access” on page 35-7

“Refine FlexRay Node for Signal Access” on page 35-7

“Generate Project Code for Signal Access” on page 35-10

To configure a FlexRay node, first install the EB tresos Busmirror configuration software and one or more FlexRay boards in your target computer. See “Install FlexRay Network and Configuration Software” on page 35-2.

This procedure configures the FlexRay network for model `dFlexRaySimpleExample`. This model consists of two FlexRay nodes, `Ramp_ECU` and `Invert_ECU`. A FlexRay node corresponds to a FlexRay board, so install two FlexRay boards in your target computer. Create a separate project for each FlexRay node.

The following procedure configures node `Ramp_ECU`, which has two signals, `RampSignal_ChA` and `RampSignal_Dyn_ChA`.

Repeat these steps for node `Invert_ECU`, which has one signal, `InvertSignal_ChA`.

Create Busmirror Project for Signal Access

The following procedure uses the `Ramp_ECU` node of model `dFlexRaySimpleExample` as an example.

The required FlexRay configuration file is:

```
matlab\toolbox\rtw\targets\xpc\xpcdemos\  
FlexRayConfigFiles\ClusterConfig\FlexRayRampDemo_Signals.xml
```

- 1 Open EB tresos Busmirror in your working folder, for example `C:\workdir`.
- 2 To create a Busmirror project for node `Ramp_ECU`, in the **Manage Projects** tab, click **New Project**.
- 3 In the **Templates** list, select **GenericRBS**.

- 4** In the **Name** text box, enter a name for the node, for example `ramp_ecu`.
- 5** To fill the **Location** text box, navigate to `C:\workdir`.
- 6** Click **Next**.
- 7** To fill the **Select file to import** text box, navigate to and select the required FlexRay configuration file.
- 8** Select the **Copy input file to 'cfg_in' directory** check box.
- 9** Click **Finish**.

The software copies the input file to the 'cfg_in' folder and import FIBEX-format data from the input file. The Busmirror window looks like this figure.

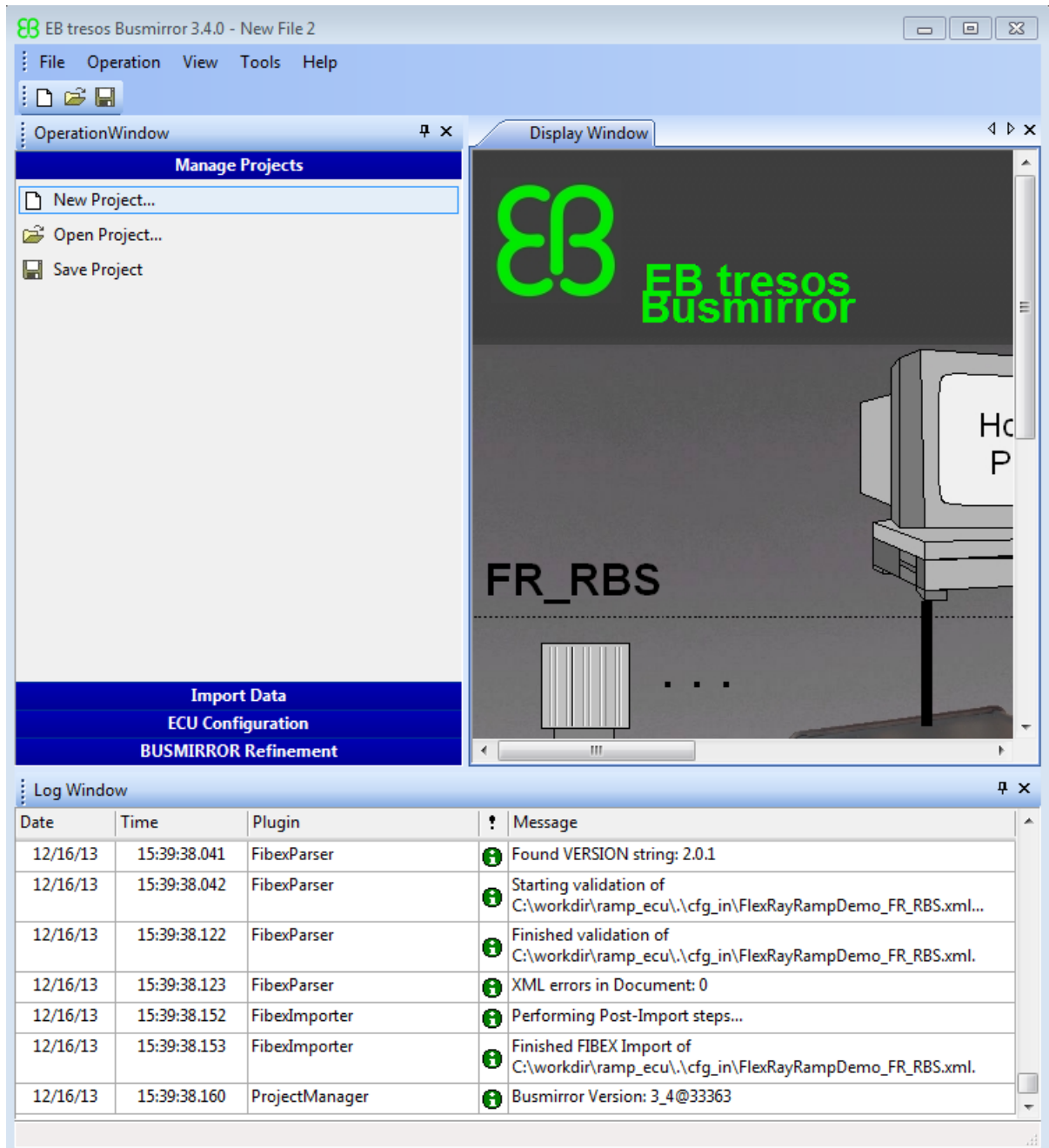

10 In the **Manage Projects** tab, click **Save Project**.

This procedure uses a configuration file specialized for this example. Template configuration files in FIBEX format (.xml) and BOR format (.bor) are supplied with the EB tresos Busmirror installation. They are stored in the **Examples** folder under the **EB \tresos_Busmirror** folder.

To create a custom configuration file, use a separate tool such as SIMTOOLS (available from www.speedgoat.ch).

If you have a custom configuration file in FIBEX format, open the **Import Data** tab and use **Import from FIBEX** to import the configuration data. This process replaces the configuration data imported while you created the project with new data from the FIBEX file.

Select FlexRay Node for Signal Access

The following procedure assumes that you have already created an EB tresos Busmirror project for node **Ramp_ECU**.

- 1** Open EB tresos Busmirror in your working folder, **C:\workdir**.
- 2** To configure the **Ramp_ECU** node, in the **ECU Configuration** tab, select **FlexRay ECU Distribution**.
- 3** In the **Real Controllers** list, select **Ramp_ECU**.

For this model, you can configure only one FlexRay node (board) per project file. In general, you can select and emulate multiple real controllers on one EB5100 FlexRay board, for example to perform RestBus simulation (RBS).

- 4** Click the **Arrow** button >.
- 5** Click **Finish**.
- 6** In the **Manage Projects** tab, click **Save Project**.

Refine FlexRay Node for Signal Access

The following procedure assumes that you have already created and saved an EB tresos Busmirror project for node **Ramp_ECU**. If you can use the EB tresos Busmirror project for node **Ramp_ECU** as it is, you can skip this step.

- 1 Open EB tresos Busmirror in your working folder, C:\workdir.
- 2 To configure the Ramp_ECU node, in the **BUSMIRROR Refinement** tab, select **Signals**.
- 3 In the **Signal** list, click RampSignal1_ChA.
- 4 In the box for property Transport Data Type, click the Continuation button  and then verify that the value is sint32 in the **Transport Data Type - 15** list.

To change this value, select the required value from the list.

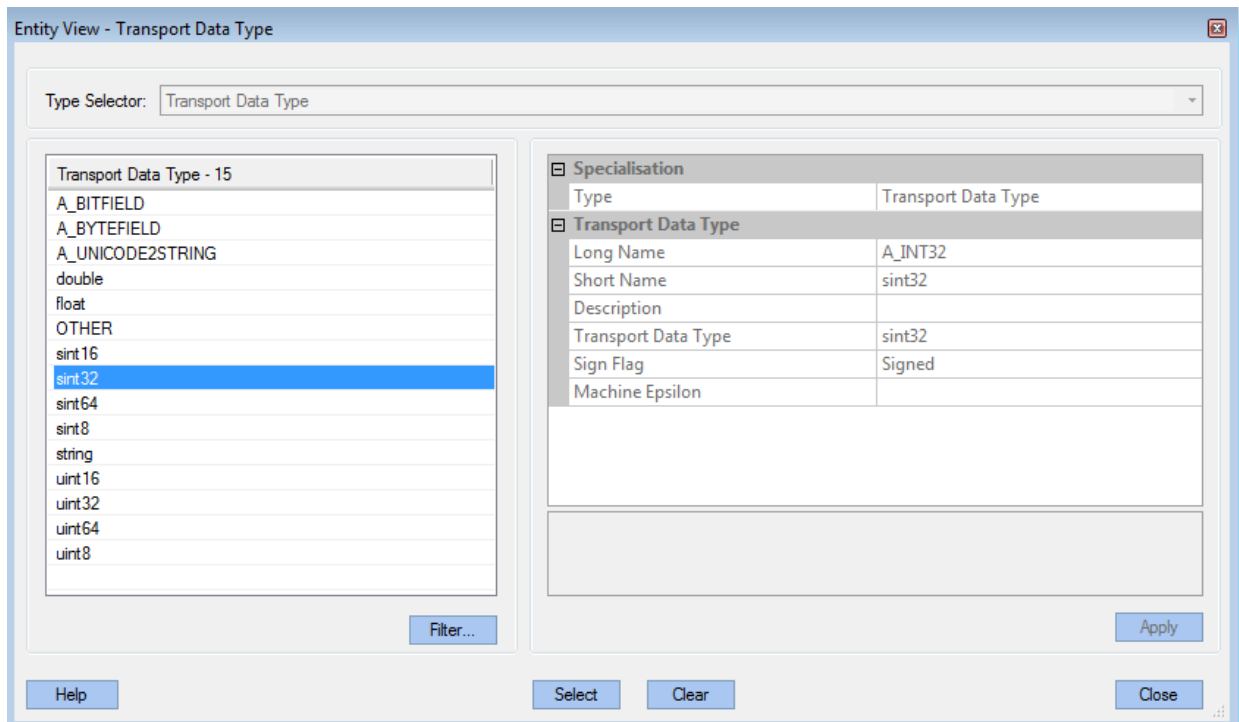

- 5 Click **Apply** and then **Close** in the **Transport Data Type** dialog box.
- 6 In the box for property Bit Size [bit], verify that the value is 32.

To change this value, type the required value in the box.

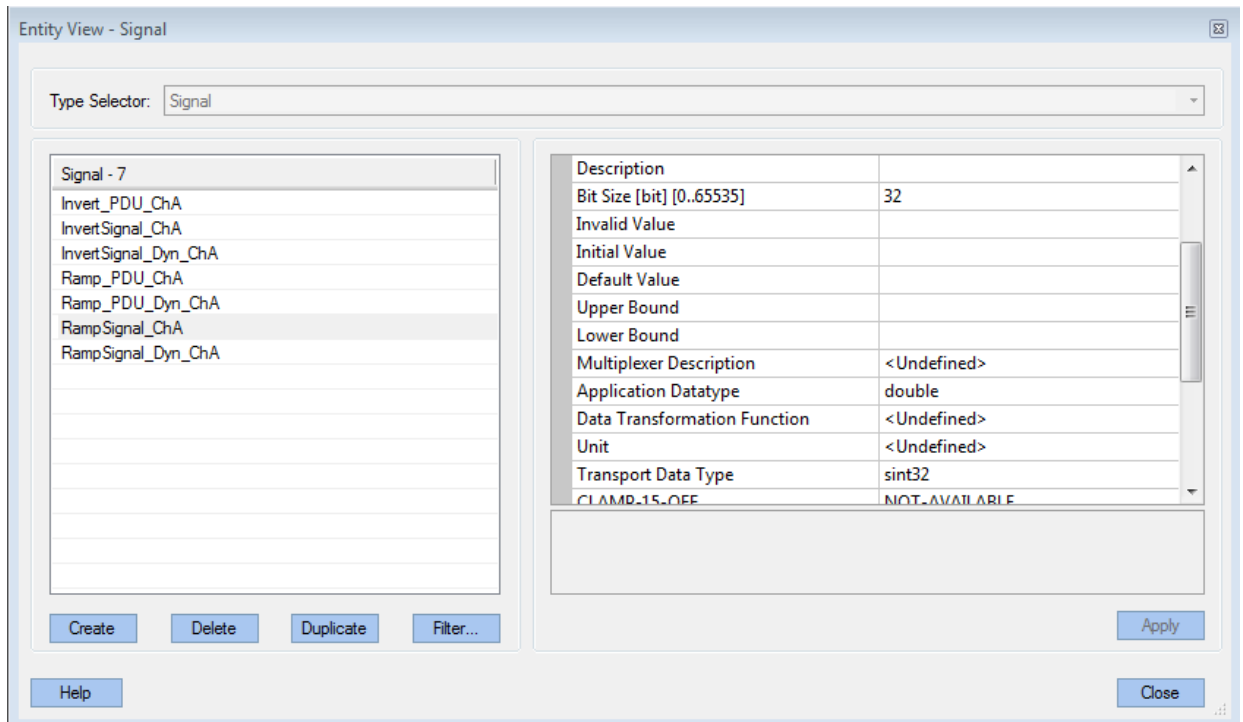

- 7 Click **Apply** and then **Close** in the **Entity View - Signal** dialog box.
- 8 In the **BUSMIRROR Refinement** tab, select **Frame-Signal Editor**.
- 9 In the **Frame - 5** list, select the line containing frame **RampFrame_ChA**.
- 10 In the **Signal - 4** list, verify that signal **RampFrame_ChA** is also checked.

To add a signal to a frame, select the signal, select the frame, and then click **Add to Frame**.

To remove a signal from a frame, select the signal, select the frame, and then click **Remove from Frame**.

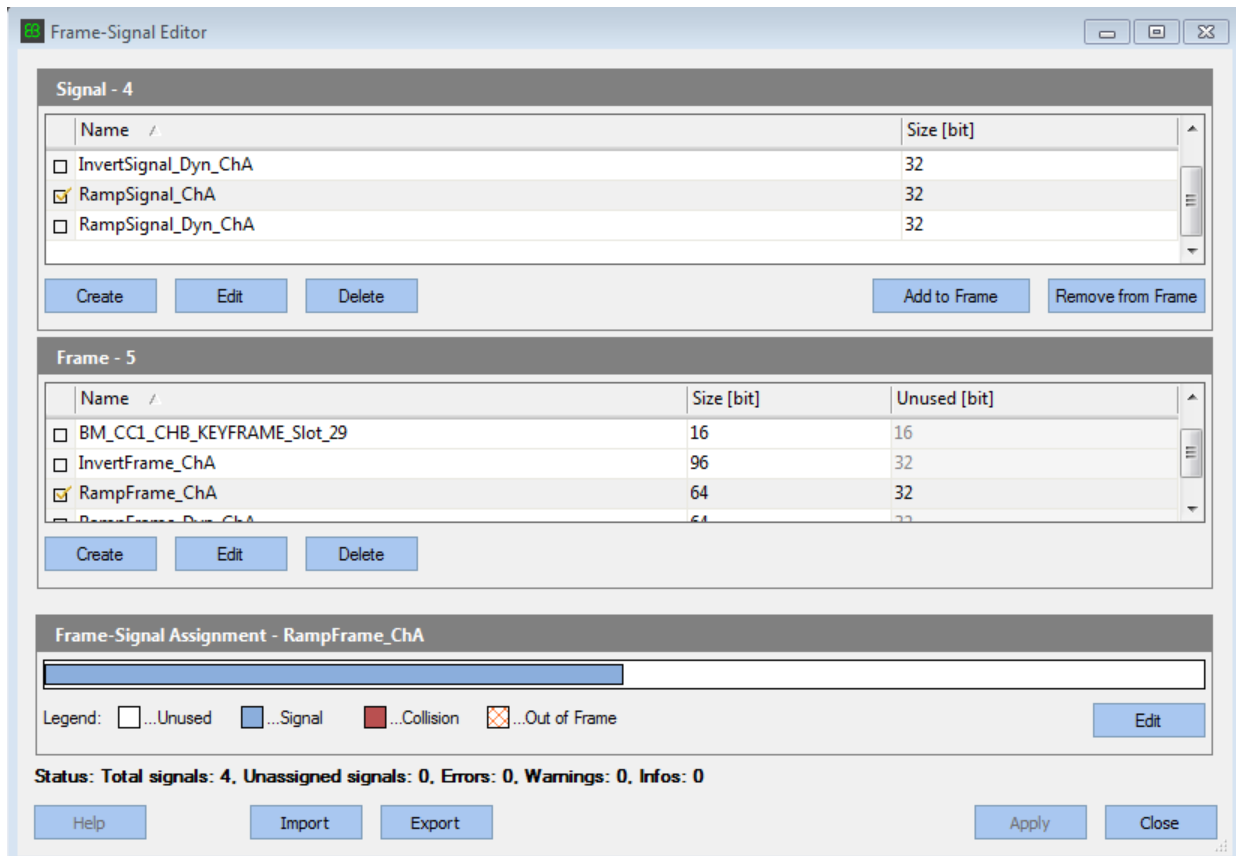

11 Click **Apply** and then **Close** in the **Frame - Signal Editor** dialog box.

12 In the **Manage Projects** tab, click **Save Project**.

Repeat these steps for signal `RampSignal_Dyn_ChA`.

Generate Project Code for Signal Access

The following procedure assumes that you have already selected and configured the EB tresos Busmirror project `Ramp_ECU`.

1 Open EB tresos Busmirror in your working folder, `C:\workdir`.

- 2 To generate code for the Ramp_ECU node, in the **ECU Configuration** tab, select **Code Generation**.
- 3 In the **Busmirror Generator** dialog box, clear the **Compile for EB2100 Platform** and **Compile for EB6100 Platform** check boxes.

Verify that the **Generate Code** check box is selected and that the **Start communication automatically** check box is cleared.

- 4 Click **Start Process**.

After code generation is complete, the dialog box looks like this figure.

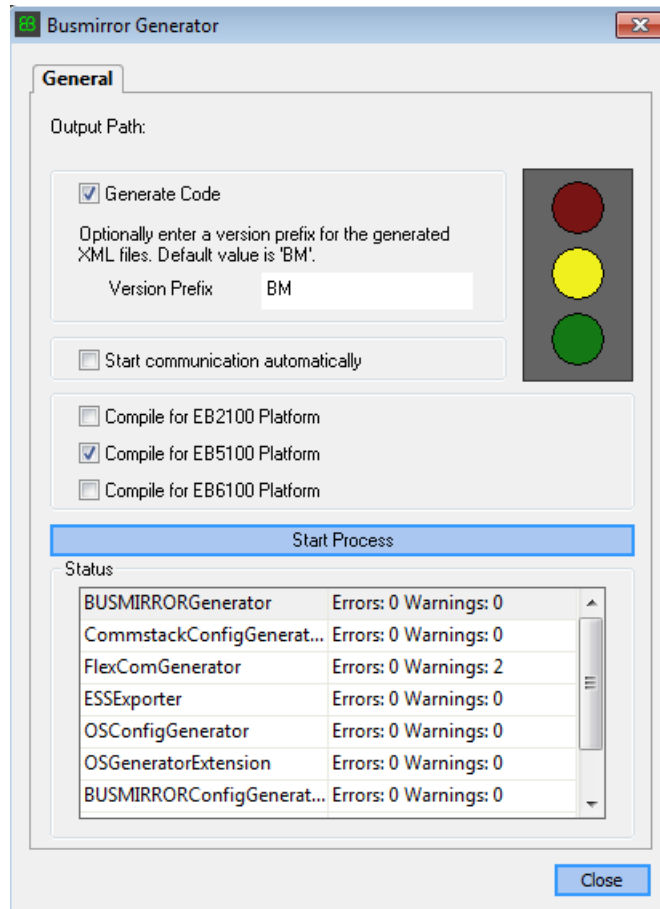

EB tresos Busmirror generates code in the project folder and subfolders.

To modify the generated code, run Busmirror, change the Busmirror configuration, and rebuild the project. Do not hand-modify the project files.

- 5** Click **Close**.
- 6** In the **Manage Projects** tab, click **Save Project**.

At the end of the build procedure, the Busmirror window looks like this figure.

EB tresos Busmirror 3.4.0 - C:\workdir\ramp_ecu\cfg_in\FrCanRBSFR_RBS.bor

File Operation View Tools Help

OperationWindow Display Window

Manage Projects

- New Project...
- Open Project...
- Save Project

Import Data
ECU Configuration
BUSMIRROR Refinement

Home

ECU Configuration

Once a system definition file has been [imported](#) the busmirror configuration can be created. Click on *Busmirror Configurator* within the Operation Window to open the *Busmirror Configurator* dialog. The *Busmirror Configurator* is used to specify the cluster to be emulated by the busmirror. For any details please refer to the user manual.

Remark: During configuration the data of the emulated ECUs will be replaced by busmirror's configuration data. The configuration process may take several minutes.

Switch to the [Busmirror Refinement](#) tab in order to review and modify the created busmirror configuration data.

To generate and compile the busmirror configuration

Log Window

Date	Time	Plugin	Message
12/16/13	16:02:42.782	Loader	"MAKE: Compiling cfg/JobDispFrCfg.c ..."
12/16/13	16:02:42.899	Loader	"MAKE: Compiling src/TUM_SignalManipCfg.c ..."
12/16/13	16:02:43.114	Loader	"MAKE: Creating obj/arch_eb5100/Firmware_debug.elf ..."
12/16/13	16:02:44.531	Loader	"MAKE: Creating obj/arch_eb5100/Firmware.elf ..."
12/16/13	16:02:44.640	Loader	"MAKE: Generating file obj/arch_eb5100/Firmware.ttc ..."
12/16/13	16:02:44.640	Loader	INFO: Build status for EB5100: OK
12/16/13	16:05:24.424	MenuWindow	Writing File: C:\workdir\ramp_ecu\cfg_in\FrCanRBSFR_RBS.bor ...
12/16/13	16:05:24.531	MenuWindow	File written. Get Memento: 0.083 s, Write File: 0.022 s, Total: 0.105 s.
12/16/13	16:05:24.531	MenuWindow	File version history: 4.4.1

Repeat these steps for node `Invert_ECU`, which has one signal, `InvertSignal_ChA`.

The next task is “Prepare FlexRay Network for Signal Access” on page 35-15.

Prepare FlexRay Network for Signal Access

To prepare the FlexRay network for execution, as required by your network, do the following steps.

- 1** Connect FlexRay cables to the channel A and B connectors on the Elektrobit EB5100 cards.

By default, cables from channel A connectors on one board connect to channel A connectors on another, and similarly for cables from channel B connectors.

- 2** Connect bus terminators to both ends of the A and B channels. The A and B channels together form the FlexRay bus.
- 3** Connect FlexRay cables to the FlexRay device.

The next task is “Prepare FlexRay Model for Signal Access” on page 35-16.

Prepare FlexRay Model for Signal Access

In this section...
“Configure FlexRay Config Blocks for Signal Access” on page 35-17
“Configure FlexRay Write Frame Signals Blocks for Signal Access” on page 35-19
“Configure FlexRay Read Frame Signals Blocks for Signal Access” on page 35-24
“Configure FlexRay POC Status Blocks for Signal Access” on page 35-26
“Configure FlexRay Model Configuration Parameters for Signal Access” on page 35-26

Ramp_ECU: Sends a static frame and a dynamic frame to Invert_ECU and reads back the received signal values

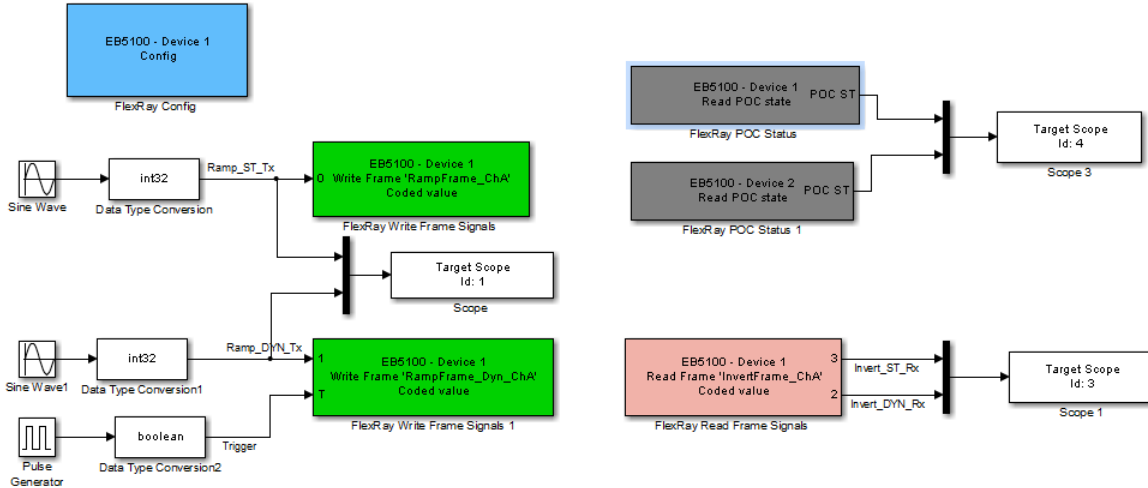

Invert_ECU: Reads frames received from Ramp_ECU and sends them back to Ramp_ECU.

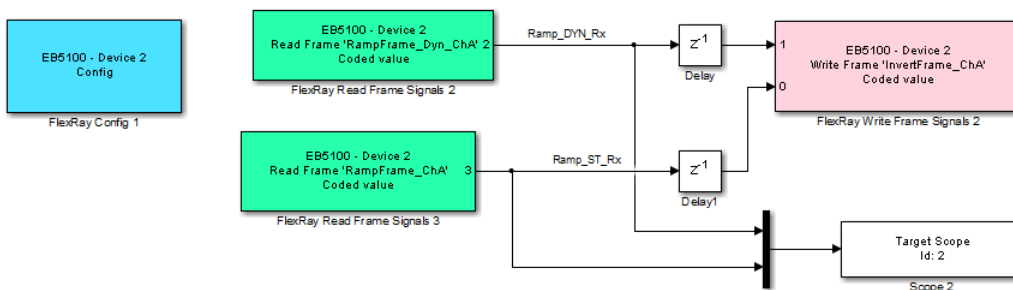

Before configuring model `dFlexRaySimpleExample`, record the bus and slot numbers of the FlexRay boards in the target computer and configure each FlexRay node.

To configure model `dFlexRaySimpleExample`, perform the following tasks.

Configure FlexRay Config Blocks for Signal Access

To configure the FlexRay Config block for signal access in model `dFlexRaySimpleExample`, execute the following steps.

- 1** Double-click the block labeled **EB5100 - Device 1 Config**. This block is the block corresponding to the **Ramp_ECU** controller.
- 2** In text box **Busmirror project file (.bmprj)**, navigate to the project folder for the **Ramp_ECU** controller and click **Project.bmprj**.
- 3** Set the **Join network on simulation start** check box.
- 4** Clear the **Enable board error codes** check box.
- 5** Set **Device index** to 1.
- 6** Type the bus and slot numbers that you recorded while installing the first FlexRay board in text boxes **PCI bus** and **PCI slot**.
- 7** Set **Sample time (-1 for inherited)** to -1.
- 8** Click **Refresh config data** to propagate the changes to the blocks that have **Device index** set to 1.

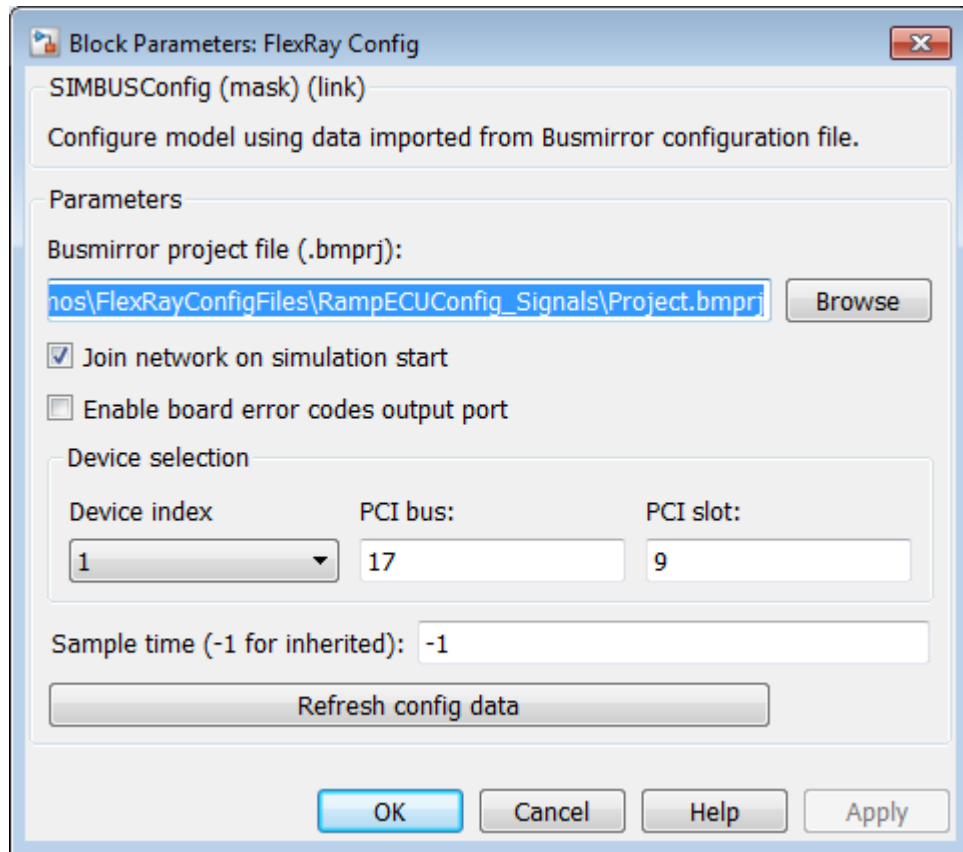

- 9 Click **OK**.

Repeat these steps for the block labeled EB5100 - Device 2 Config. This block is the block that models the Invert_ECU controller, with **Device index** 2.

Configure FlexRay Write Frame Signals Blocks for Signal Access

To send a message using FlexRay in model dFlexRaySimpleExample, configure the FlexRay Write Frame Signals blocks.

- 1 Double-click the block labeled EB5100 - Device 1 Write Frame 'RampFrame_ChA'.

- 2** Set **Device index** to 1.

The frame description fills in with information from the FlexRay configuration file for the Ramp_ECU controller.

- 3** Set **Frame label** to RampFrame_ChA.

This frame is a static frame. You can execute it only with a **Timing** value of **cyclic**. The **Trigger edge** list is disabled.

- 4** Set **Signals access level** to Coded.

- 5** Set **Sample time (-1 for inherited)** to -1.

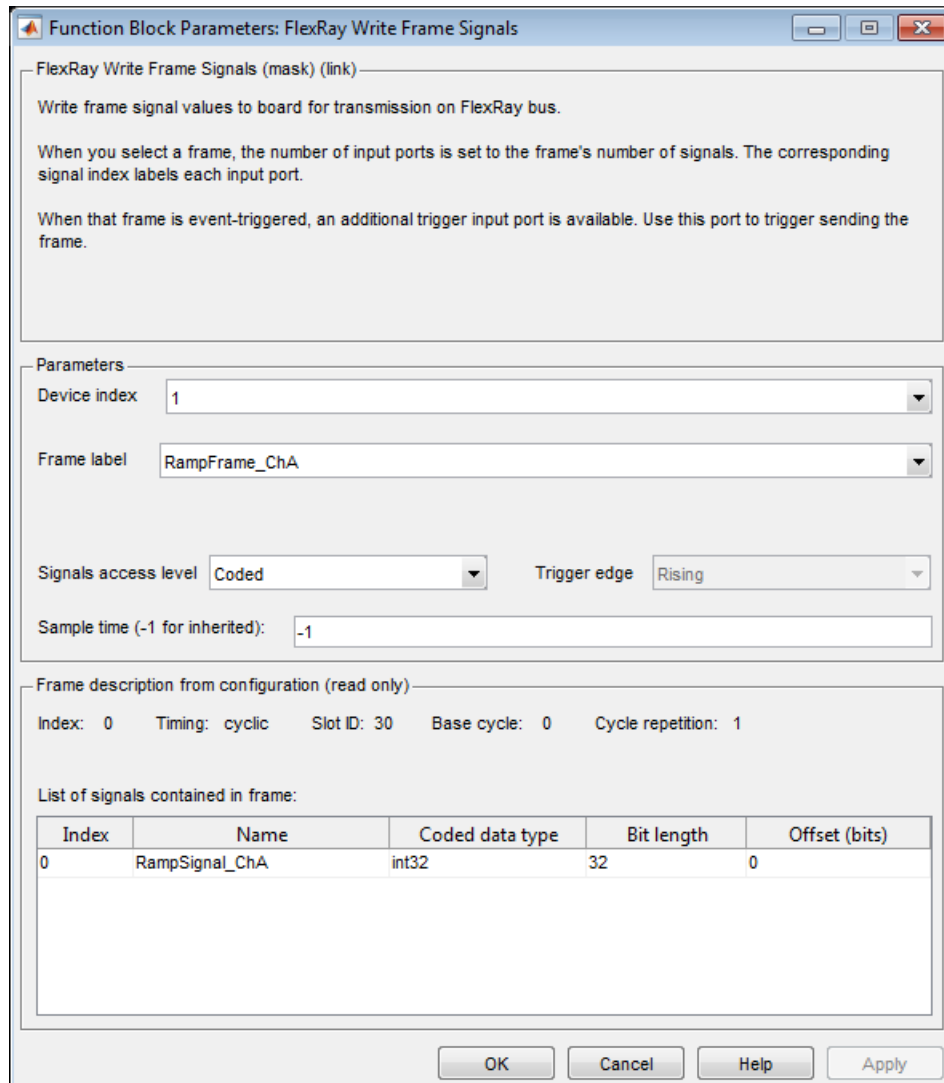

Function Block Parameters: FlexRay Write Frame Signals

FlexRay Write Frame Signals (mask) (link)

Write frame signal values to board for transmission on FlexRay bus.

When you select a frame, the number of input ports is set to the frame's number of signals. The corresponding signal index labels each input port.

When that frame is event-triggered, an additional trigger input port is available. Use this port to trigger sending the frame.

Parameters

Device index: 1

Frame label: RampFrame_ChA

Signals access level: Coded

Trigger edge: Rising

Sample time (-1 for inherited): -1

Frame description from configuration (read only)

Index: 0 Timing: cyclic Slot ID: 30 Base cycle: 0 Cycle repetition: 1

List of signals contained in frame:

Index	Name	Coded data type	Bit length	Offset (bits)
0	RampSignal_ChA	int32	32	0

OK Cancel Help Apply

- 6 Click **OK**.
- 7 Double-click the block labeled EB5100 - Device 1 Write Frame 'RampFrame_Dyn_ChA'.
- 8 Set **Device index** to 1.

The frame description fills in with information from the FlexRay configuration file for the Ramp_ECU controller.

- 9** Set **Frame label** to RampFrame_Dyn_ChA.
- 10** Set **Signals access level** to Coded.
- 11** Set **Trigger edge** to Either.

This frame is a dynamic frame. Only dynamic frames can have a **Timing** value of event.

- 12** Set **Sample time (-1 for inherited)** to -1.

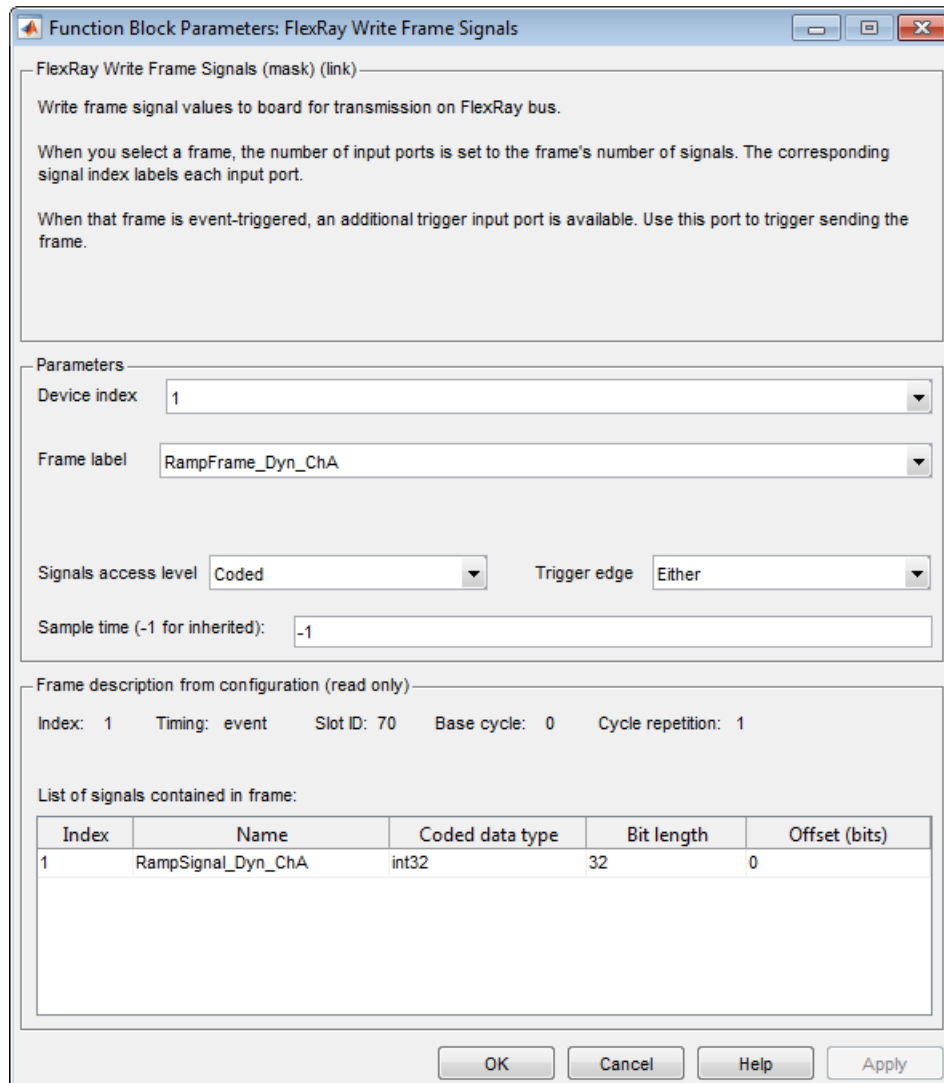

13 Click **OK**.

Repeat these steps for the block labeled EB5100 - Device 2 Write Frame 'InvertFrame_ChA'. This block is associated with the Invert_ECU controller, with **Device index 2**.

Configure FlexRay Read Frame Signals Blocks for Signal Access

To receive a message using FlexRay in model `dFlexRaySimpleExample`, configure the FlexRay Read Frame Signals blocks.

1 Double-click the block labeled `EB5100 - Device 1 Read Frame` 'InvertFrame_ChA'.

2 Set **Device index** to 1.

The frame description fills in with information from the FlexRay configuration file for the `Ramp_ECU` controller.

3 Set **Frame label** to `InvertFrame_ChA`.

4 Set **Signals access level** to `Coded`.

5 Clear the **Enable update status output port** and **Enable validity output port** check boxes.

6 Set **Sample time (-1 for inherited)** to -1.

Function Block Parameters: FlexRay Read Frame Signals

FlexRay Read Frame Signals (mask) (link)

Receive frame signal values from board.

When you select a frame, the number of output ports is set to the frame's number of signals. The corresponding signal index labels each output port.

If you enable the update status output port, when all signals are updated, the update status port output value becomes true.

If you enable the validity output port, if an invalid value is received from at least one signal, the validity port output value becomes true.

Parameters

Device index: 1

Frame label: InvertFrame_ChA

Signals access level: Coded

Enable update status output port

Enable validity output port

Sample time (-1 for inherited): -1

Frame description from configuration (read only)

Index: 4 Timing: cyclic Slot ID: 50 Base cycle: 0 Cycle repetition: 1

List of signals contained in frame:

Index	Name	Coded data type	Bit length	Offset (bits)
3	InvertSignal_ChA	int32	32	0
2	InvertSignal_Dyn_ChA	int32	32	40

OK Cancel Help Apply

7 Click **OK**.

Repeat these steps for the blocks labeled EB5100 - Device 2 Read Frame 'RampFrame_Dyn_ChA' and EB5100 - Device 2 Read Frame 'RampFrame_ChA'. These blocks are associated with the Invert_ECU controller, with **Device index 2**.

Configure FlexRay POC Status Blocks for Signal Access

To monitor the functioning of the FlexRay network in model dFlexRaySimpleExample, configure the FlexRay POC Status blocks.

- 1 Double-click the block labeled EB5100 - Device 1 Read POC state.
- 2 Set **Device index** to 1.
- 3 Set **Sample time (-1 for inherited)** to -1.
- 4 Click **OK**.

Repeat these steps for the block labeled EB5100 - Device 2 Read POC state. This block is associated with the Invert_ECU controller, with **Device index 2**.

Configure FlexRay Model Configuration Parameters for Signal Access

FlexRay is a time-triggered protocol. To synchronize the model with the FlexRay communication cycle, in the Configuration Parameters dialog box, specify a time trigger generated by the FlexRay board. To configure model dFlexRaySimpleExample for synchronous operation, perform the following steps.

- 1 In the Configuration Parameters dialog box, expand the **Code Generation** node and then the **Simulink Real-Time Options** node.
- 2 Clear the **Use default communication timeout** check box.
- 3 Calculate $25 \text{ seconds} * \# \text{ of FlexRay boards}$. Type this value into the box **Specify the communication timeout in seconds**.

This value is an estimate of the time required to download the configuration data into the flash memory for the FlexRay boards.

- 4 In the **Execution mode** list, select **Real-Time**.
- 5 In the **Real-time interrupt source** list, select **Auto (PCI only)**.
- 6 In the **I/O board generating the interrupt** list, select **Busmirror EB5100**.
- 7 Take the defaults for the other configuration parameters.

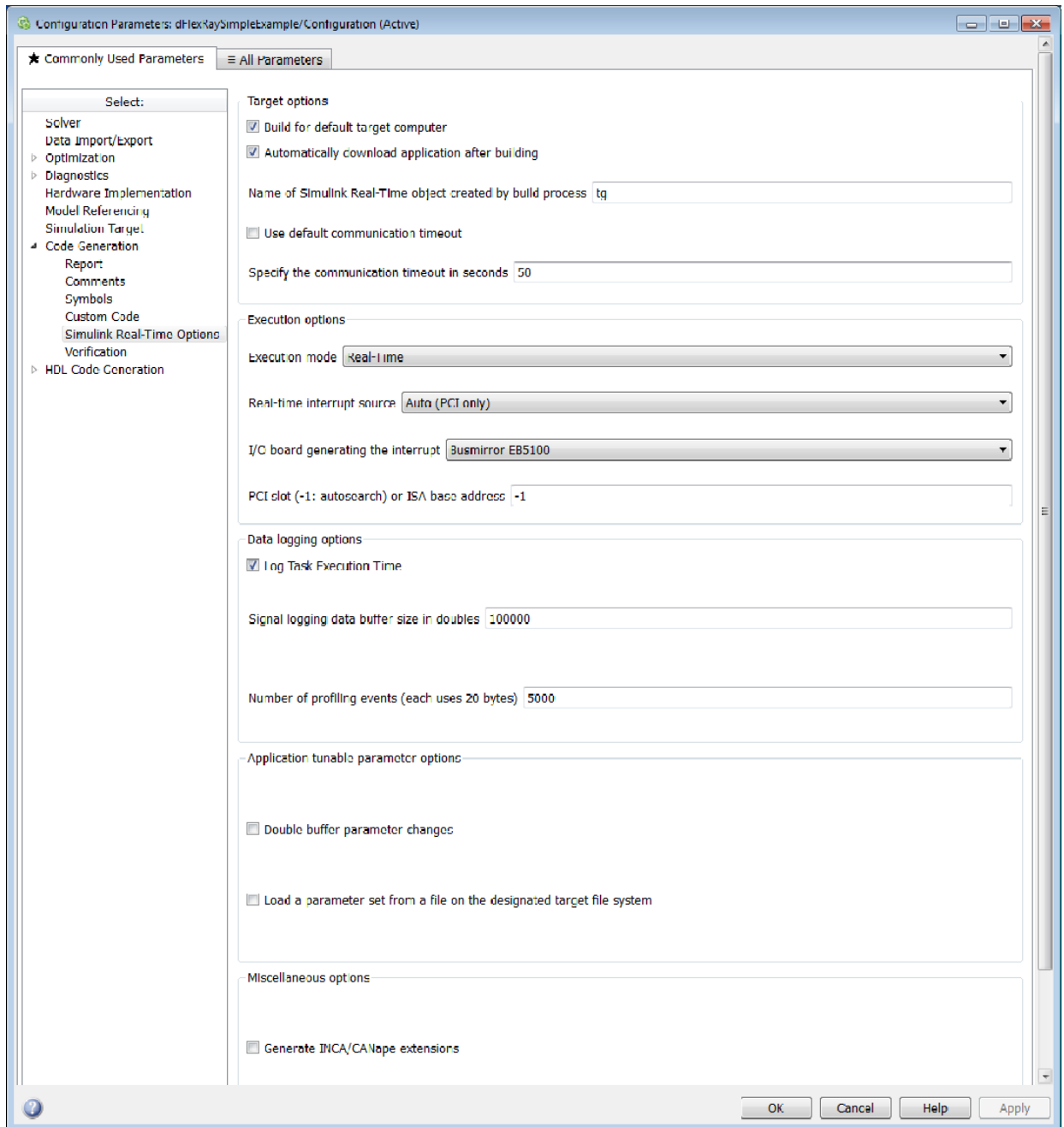

8 Click **OK**.

The next tasks are to build, download, and execute the model.

The FlexRay libraries are licensed. For the first build of a FlexRay model, specify the folder where the license file resides. If you hold a floating license, specify the address of the license server.

Configure FlexRay Node for PDU Access

To configure a FlexRay node, first install the EB tresos Busmirror configuration software and one or more FlexRay boards in your target computer. See “Install FlexRay Network and Configuration Software” on page 35-2.

This procedure configures the FlexRay network for model `dFlexRaySimpleExample`. This model consists of two FlexRay nodes, `Ramp_ECU` and `Invert_ECU`. A FlexRay node corresponds to a FlexRay board, so install two FlexRay boards in your target computer. Create a separate project for each FlexRay node.

The following procedure configures node `Ramp_ECU`.

Repeat these steps for node `Invert_ECU`.

Create Busmirror Project for PDU Access

The following procedure uses the `Ramp_ECU` node of model `dFlexRaySimpleExample_PDU` as an example.

The required FlexRay configuration file is:

```
matlab\toolbox\rtw\targets\xpc\xpcdemos\  
FlexRayConfigFiles\ClusterConfig\FlexRayRampDemo_PDU.xml
```

- 1 Open EB tresos Busmirror in your working folder, for example `C:\workdir`.
- 2 To create a Busmirror project for node `Ramp_ECU`, in the **Manage Projects** tab, click **New Project**.
- 3 In the **Templates** list, select `GenericRBS`.
- 4 In the **Name** text box, enter a name for the node, for example `ramp_ecu`.
- 5 To fill the **Location** text box, navigate to `C:\workdir`.
- 6 Click **Next**.
- 7 To fill the **Select file to import** text box, navigate to and select the required FlexRay configuration file.
- 8 Select the **Copy input file to 'cfg_in' directory** check box.
- 9 Click **Finish**.

The software copies the input file to the 'cfg_in' folder and import FIBEX-format data from the input file. The Busmirror window looks like this figure.

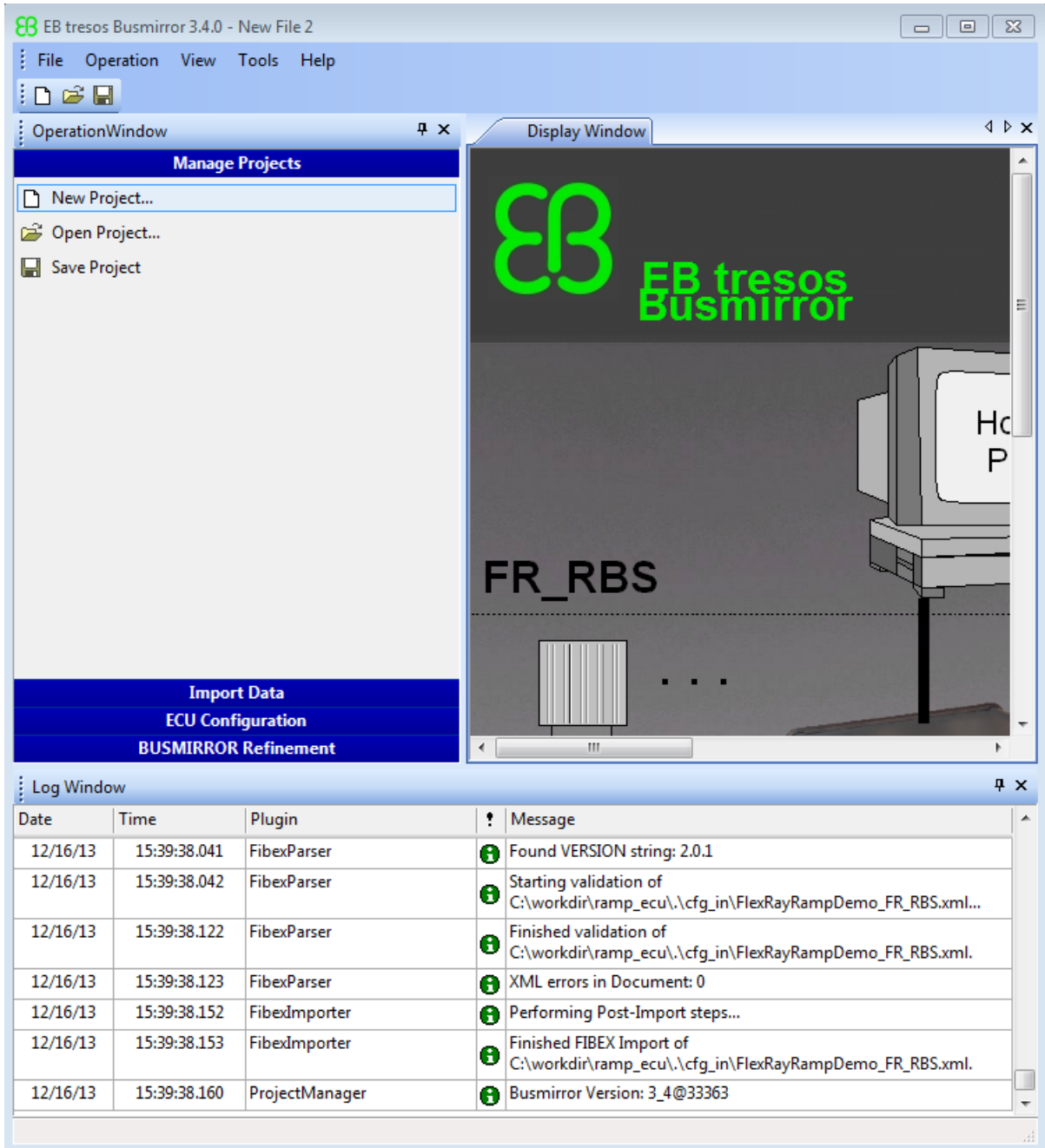

10 In the **Manage Projects** tab, click **Save Project**.

This procedure uses a configuration file specialized for this example. Template configuration files in FIBEX format (.xml) and BOR format (.bor) are supplied with the EB tresos Busmirror installation. They are stored in the **Examples** folder under the **EB \tresos_Busmirror** folder.

To create a custom configuration file, use a separate tool such as SIMTOOLS (available from www.speedgoat.ch).

If you have a custom configuration file in FIBEX format, open the **Import Data** tab and use **Import from FIBEX** to import the configuration data. This process replaces the configuration data imported while you created the project with new data from the FIBEX file.

Select FlexRay Node for PDU Access

The following procedure assumes that you have already created an EB tresos Busmirror project for node **Ramp_ECU**.

- 1** Open EB tresos Busmirror in your working folder, **C:\workdir**.
- 2** To configure the **Ramp_ECU** node, in the **ECU Configuration** tab, select **FlexRay ECU Distribution**.
- 3** In the **Real Controllers** list, select **Ramp_ECU**.

For this model, you can configure only one FlexRay node (board) per project file. In general, you can select and emulate multiple real controllers on one EB5100 FlexRay board, for example to perform RestBus simulation (RBS).

- 4** Click the **Arrow** button >.
- 5** Click **Finish**.
- 6** In the **Manage Projects** tab, click **Save Project**.

Refine FlexRay Node for PDU Access

The following procedure assumes that you have already created and saved an EB tresos Busmirror project for node **Ramp_ECU**. If you can use the EB tresos Busmirror project for node **Ramp_ECU** as it is, you can skip this step.

- 1 Open EB tresos Busmirror in your working folder, C:\workdir.
- 2 To configure the Ramp_ECU node, in the **BUSMIRROR Refinement** tab, select **Signal-PDU Editor**.
- 3 In the **PDU- 3** list, click Ramp_PDU_ChA.
- 4 In the **Signal - 4** list, verify that signal RampSignal_ChA is also checked.

To add a signal to a PDU, select the signal, select the PDU, and then click **Add to PDU**.

To remove a signal from a PDU, select the signal, select the PDU, and then click **Remove from PDU**.

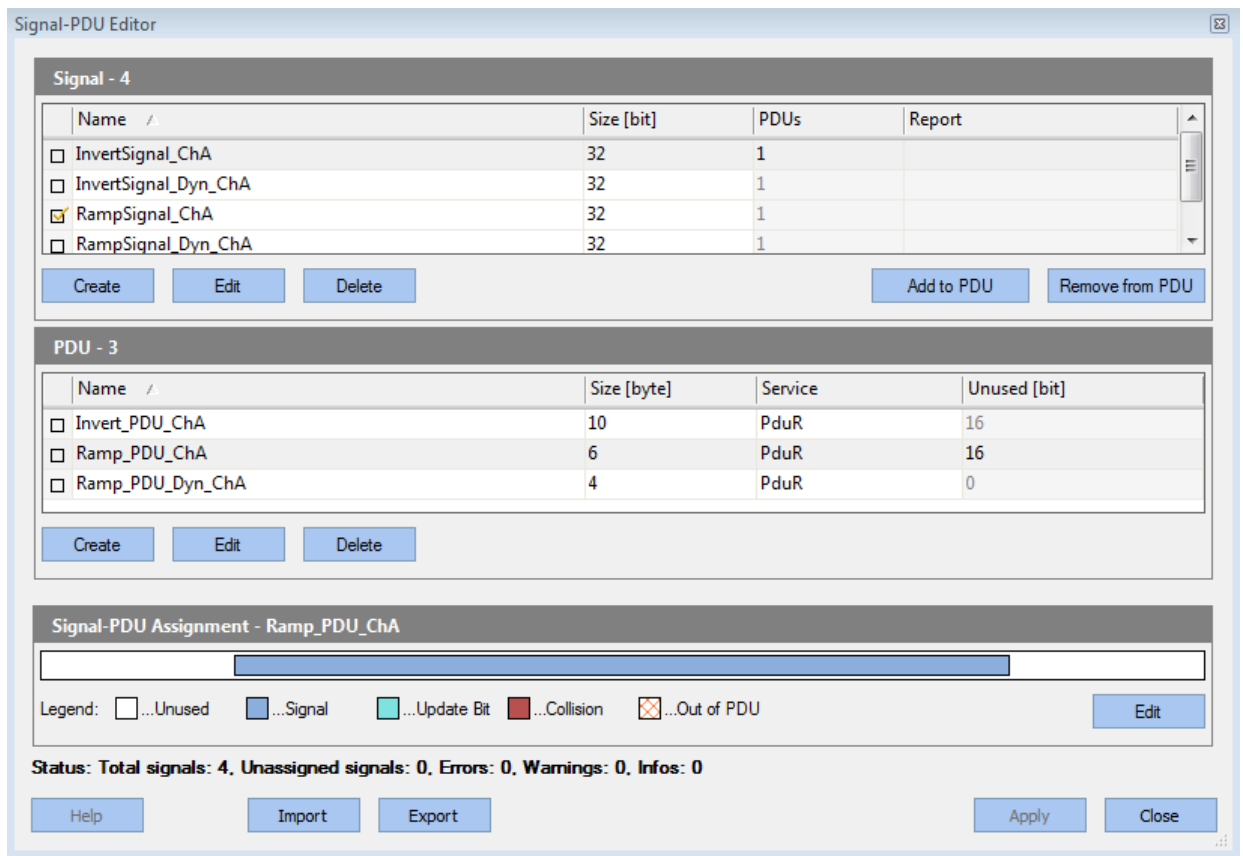

- 5 Click **Apply**, and then **Close**.
- 6 In the **BUSMIRROR Refinement** tab, select **PDU - Frame Editor**.
- 7 In the **Frame - 5** list, select the line containing frame RampFrame_ChA.
- 8 In the **PDU - 3** list, verify that PDU Ramp_PDU_ChA is also checked.

To add a PDU to a frame, select the PDU, select the frame, and then click **Add to Frame**.

To remove a PDU from a frame, select the PDU, select the frame, and then click **Remove from Frame**.

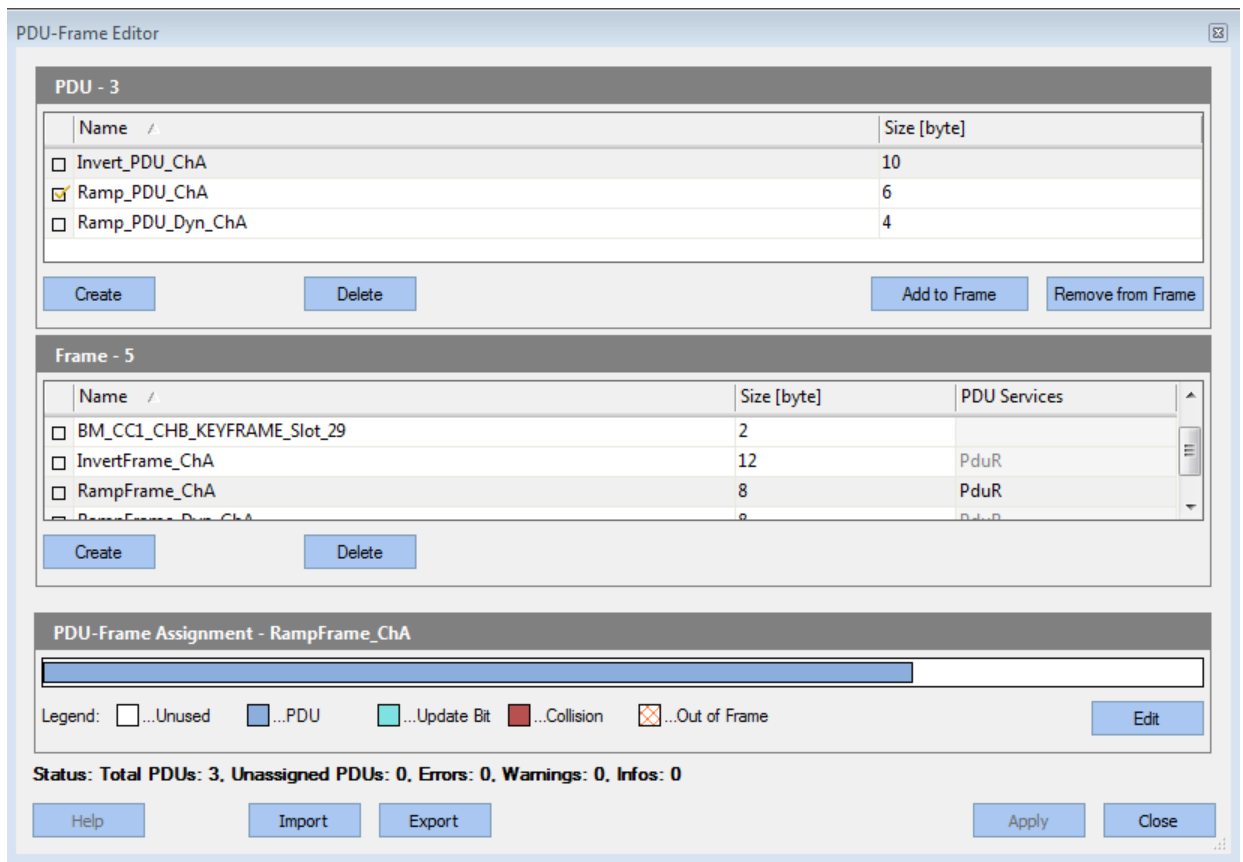

- 9 Click **Apply** and then **Close** in the **Frame - Signal Editor** dialog box.

10 In the **Manage Projects** tab, click **Save Project**.

Repeat these steps for PDU Ramp_PDU_Dyn_ChA.

Generate Project Code for PDU Access

The following procedure assumes that you have already selected and configured the EB tresos Busmirror project Ramp_ECU.

- 1** Open EB tresos Busmirror in your working folder, **C:\workdir**.
- 2** To generate code for the Ramp_ECU node, in the **ECU Configuration** tab, select **Code Generation**.
- 3** In the **Busmirror Generator** dialog box, clear the **Compile for EB2100 Platform** and **Compile for EB6100 Platform** check boxes.

Verify that the **Generate Code** check box is selected and that the **Start communication automatically** check box is cleared.

- 4** Click **Start Process**.

After code generation is complete, the dialog box looks like this figure.

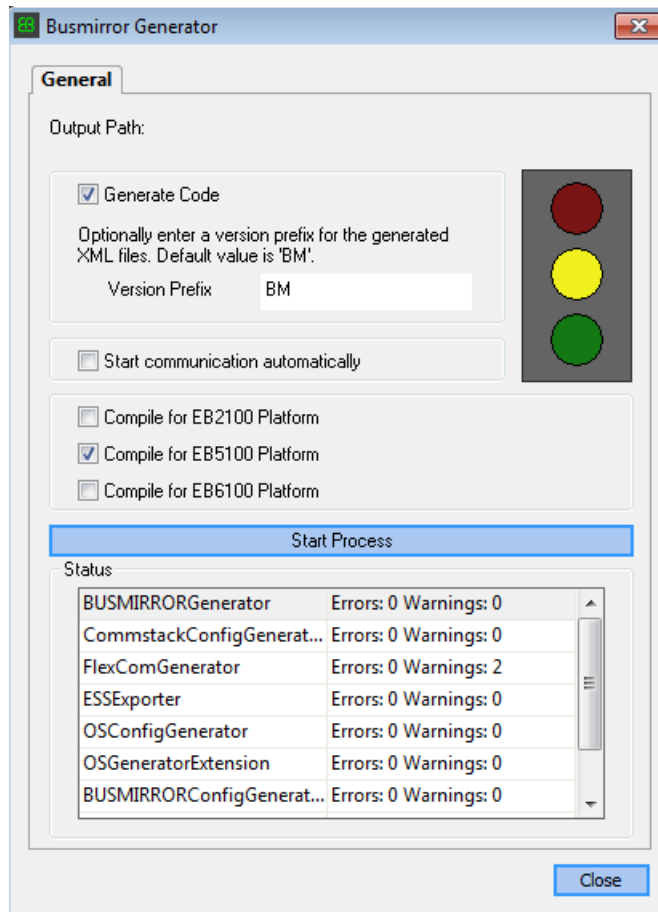

EB tresos Busmirror generates code in the project folder and subfolders.

To modify the generated code, run Busmirror, change the Busmirror configuration, and rebuild the project. Do not hand-modify the project files.

- 5 Click **Close**.
- 6 In the **Manage Projects** tab, click **Save Project**.

At the end of the build procedure, the Busmirror window looks like this figure.

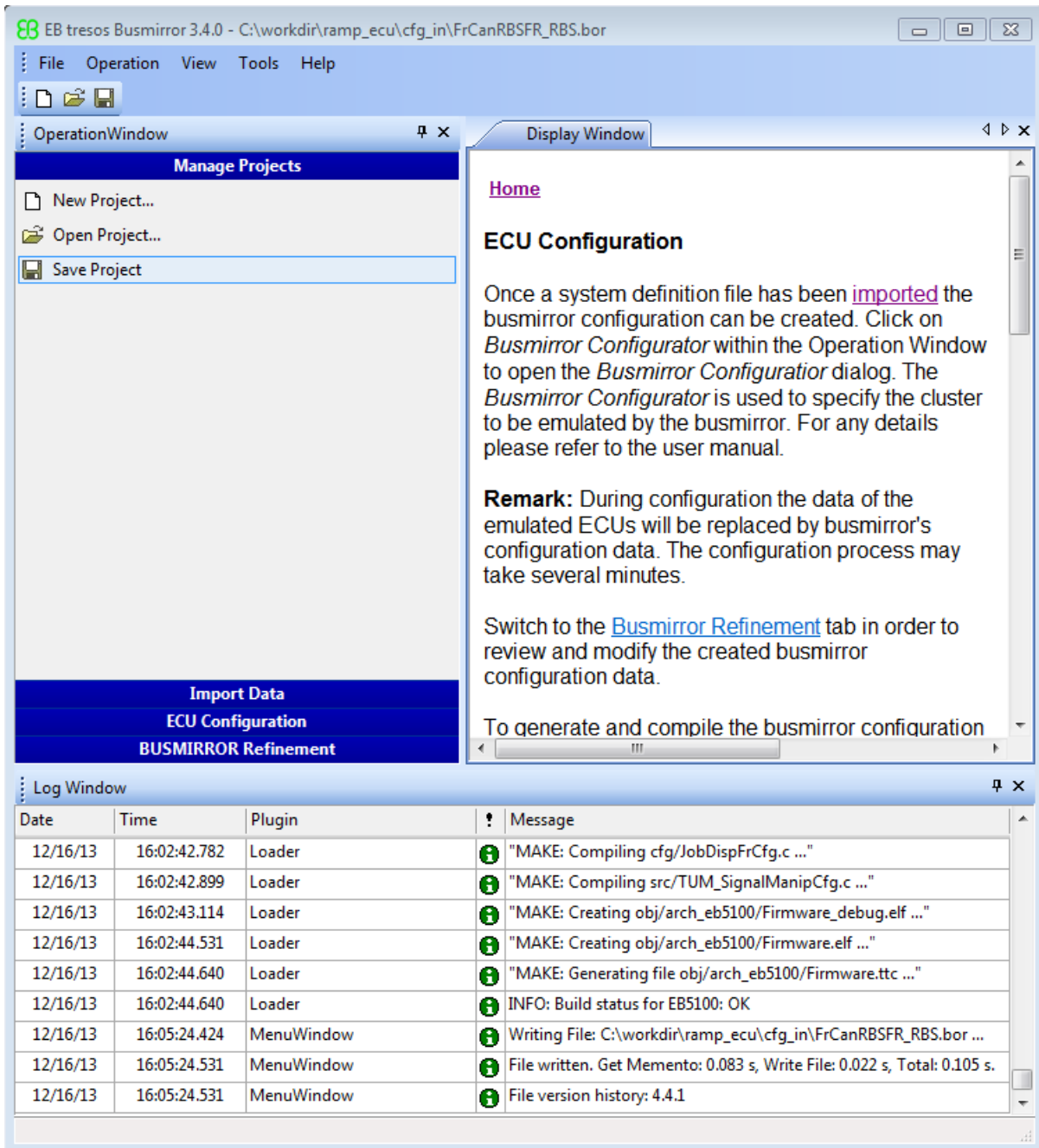

Repeat these steps for node `Invert_ECU`.

The next task is “Prepare FlexRay Network for PDU Access” on page 35-39.

Prepare FlexRay Network for PDU Access

To prepare the FlexRay network for execution, as required by your network, do the following steps.

- 1** Connect FlexRay cables to the channel A and B connectors on the Elektrobit EB5100 cards.

By default, cables from channel A connectors on one board connect to channel A connectors on another, and similarly for cables from channel B connectors.

- 2** Connect bus terminators to both ends of the A and B channels. The A and B channels together form the FlexRay bus.
- 3** Connect FlexRay cables to the FlexRay device.

The next task is “Prepare FlexRay Model for PDU Access” on page 35-40.

Prepare FlexRay Model for PDU Access

Ramp_ECU: Sends PDUs in a static frame and a dynamic frame to Invert_ECU and reads back the received PDU

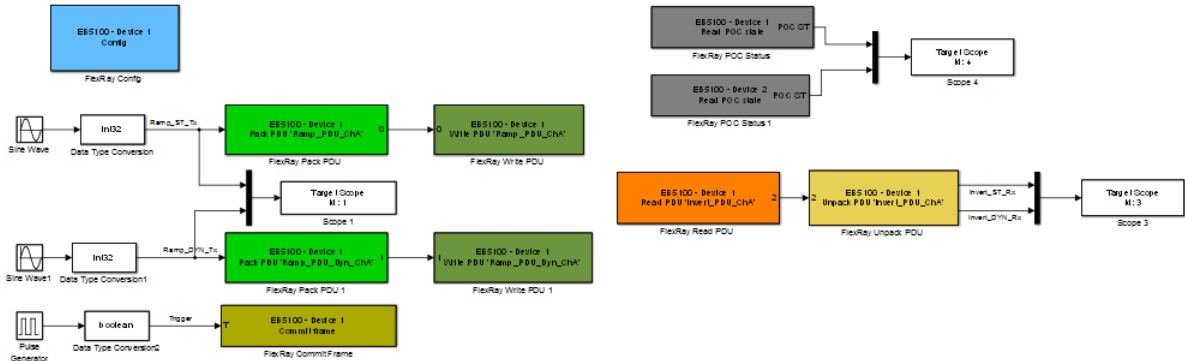

Invert_ECU: Reads PDU received from Ramp_ECU and sends back the received signals to Ramp_ECU.

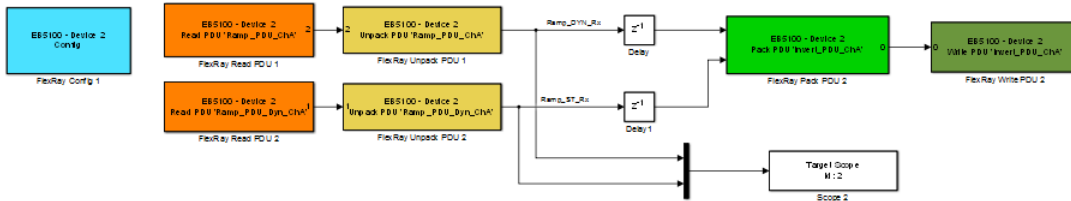

Before configuring model `dFlexRaySimpleExample_PDU`, record the bus and slot numbers of the FlexRay boards in the target computer and configure each FlexRay node.

To configure model `dFlexRaySimpleExample_PDU`, perform the following tasks.

Configure FlexRay Config Blocks for PDU Access

To configure the FlexRay Config block for PDU access in model `dFlexRaySimpleExample_PDU`, execute the following steps.

- 1 Double-click the block labeled **EB5100 - Device 1 Config**. This block is the block corresponding to the Ramp_ECU controller.
- 2 In text box **Busmirror project file (.bmprj)**, navigate to the project folder for the Ramp_ECU controller and click **Project.bmprj**.
- 3 Set the **Join network on simulation start** check box.

- 4 Clear the **Enable board error codes** check box.
- 5 Set **Device index** to 1.
- 6 Type the bus and slot numbers that you recorded while installing the first FlexRay board in text boxes **PCI bus** and **PCI slot**.
- 7 Set **Sample time (-1 for inherited)** to -1.
- 8 Click **Refresh config data** to propagate the changes to the blocks that have **Device index** set to 1.

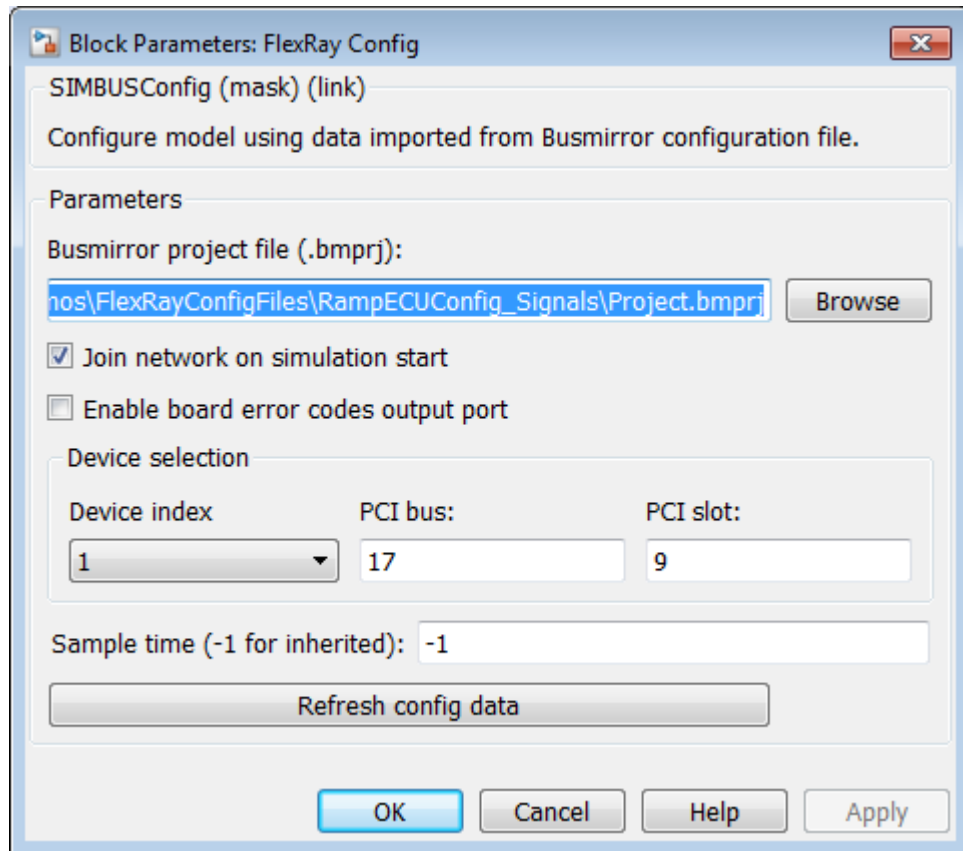

- 9 Click **OK**.

Repeat these steps for the block labeled **EB5100 - Device 2 Config**. This block is the block that models the **Invert_ECU** controller, with **Device index 2**.

Configure FlexRay Pack PDU Blocks

To pack signals into FlexRay Protocol Data Units (PDUs) in model `dFlexRaySimpleExample_PDU`, configure the FlexRay Pack PDU blocks.

- 1** Double-click the block labeled `EB5100 - Device 1 Pack PDU 'Ramp_PDU_ChA'`.
- 2** Set **Device index** to 1.
- 3** Set **PDU label** to `Ramp_PDU_ChA`.

The PDU description fills in with information from the FlexRay configuration file for the `Ramp_ECU` controller.

- 4** Set **Sample time (-1 for inherited)** to -1.

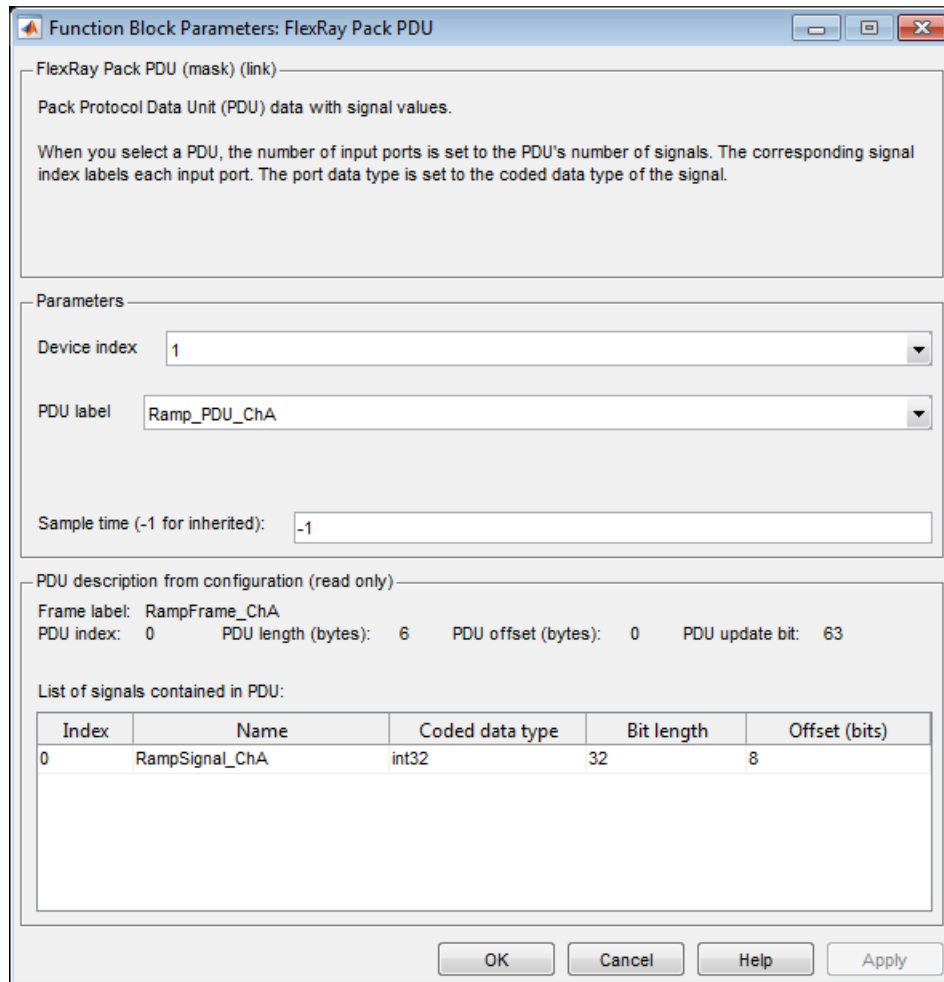

- 5 Click **OK**.
- 6 Double-click the block labeled EB5100 - Device 1 Pack PDU 'Ramp_PDU_Dyn_ChA'.
- 7 Set **Device index** to 1.

The PDU description fills in with information from the FlexRay configuration file for the Ramp_ECU controller.

- 8 Set **PDU label** to Ramp_PDU_Dyn_ChA.
- 9 Set **Sample time (-1 for inherited)** to -1.

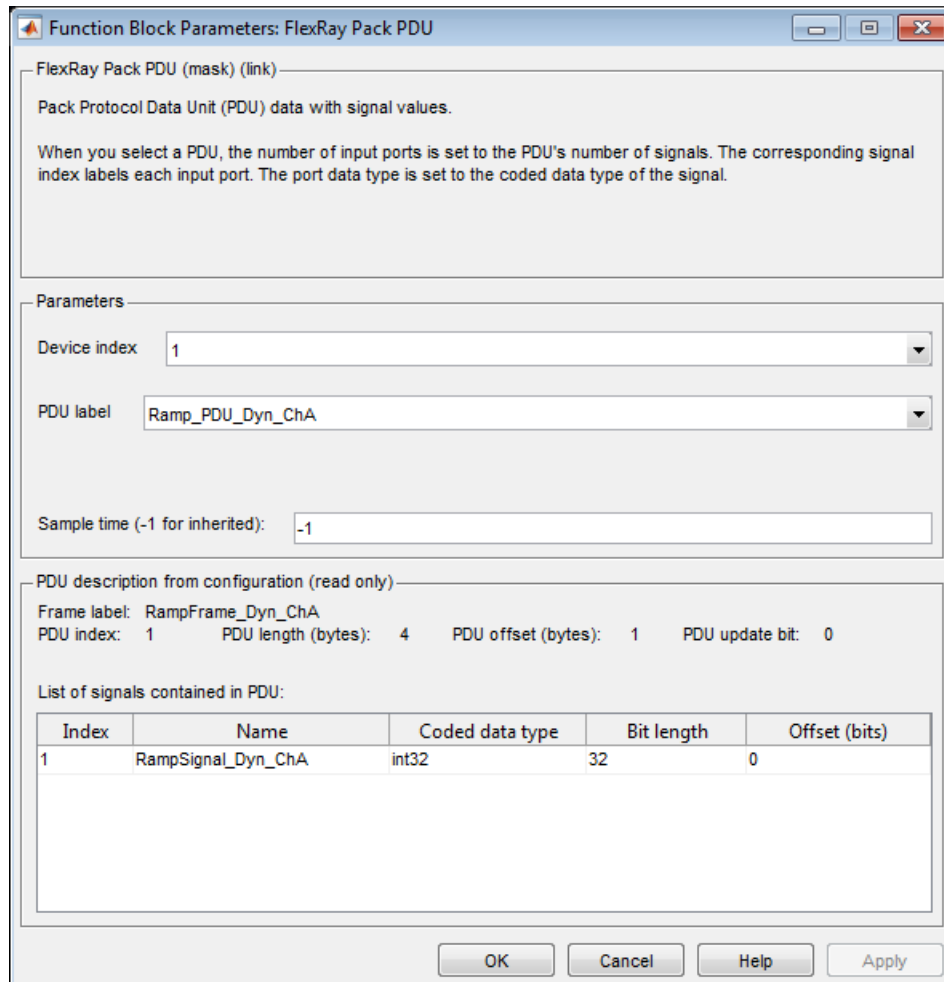

- 10 Click **OK**.

Repeat these steps for the block labeled EB5100 - Device 2 Pack PDU 'Invert_PDU_ChA'. This block is associated with the Invert_ECU controller, with **Device index 2**.

Configure FlexRay Write PDU Blocks

To send a message using FlexRay in model dFlexRaySimpleExample_PDU, configure the FlexRay Write PDU blocks.

- 1** Double-click the block labeled EB5100 - Device 1 Write PDU 'Ramp_PDU_ChA'.
- 2** Set **Device index** to 1.

The PDU description fills in with information from the FlexRay configuration file for the Ramp_ECU controller.

- 3** Set **PDU label** to Ramp_PDU_ChA.
- 4** Set **Sample time (-1 for inherited)** to -1.

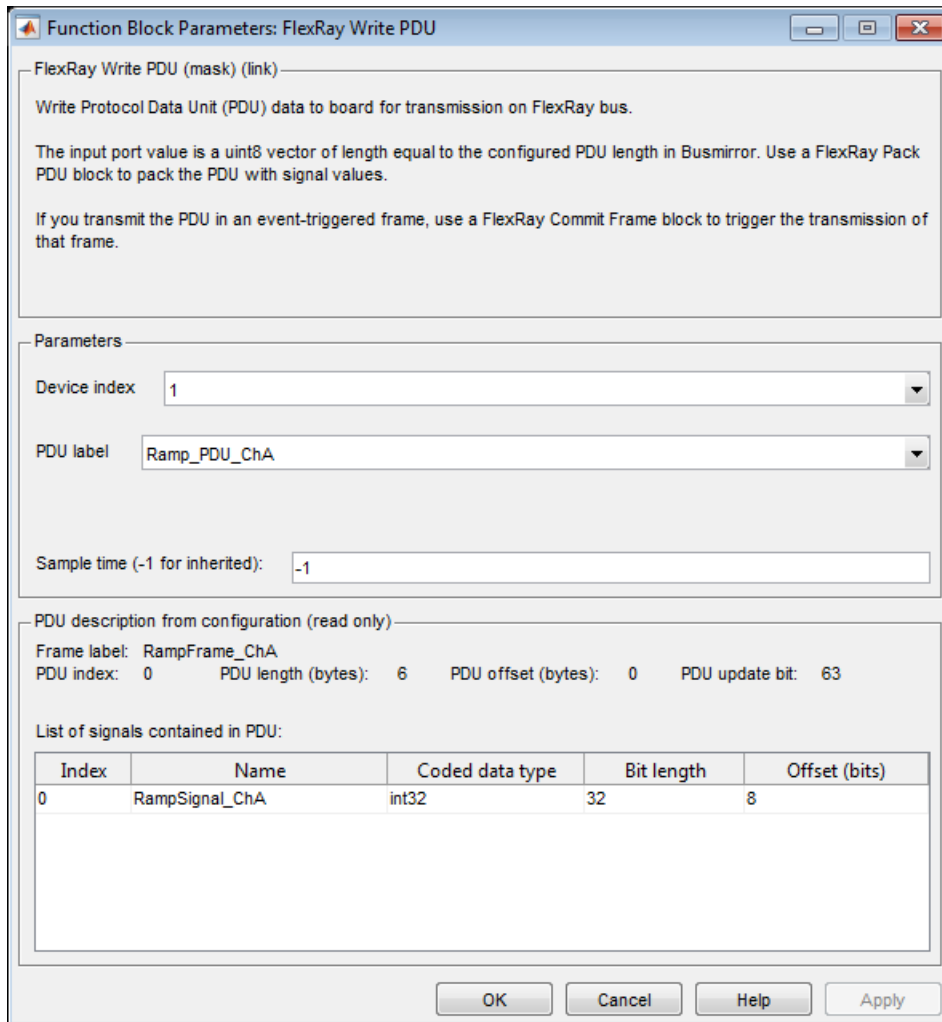

- 5 Click **OK**.
- 6 Double-click the block labeled EB5100 - Device 1 Write PDU 'Ramp_PDU_Dyn_chA'.
- 7 Set **Device index** to 1.

The PDU description fills in with information from the FlexRay configuration file for the Ramp_ECU controller.

- 8 Set **PDU label** to Ramp_PDU_Dyn_ChA.
- 9 Set **Sample time (-1 for inherited)** to -1.

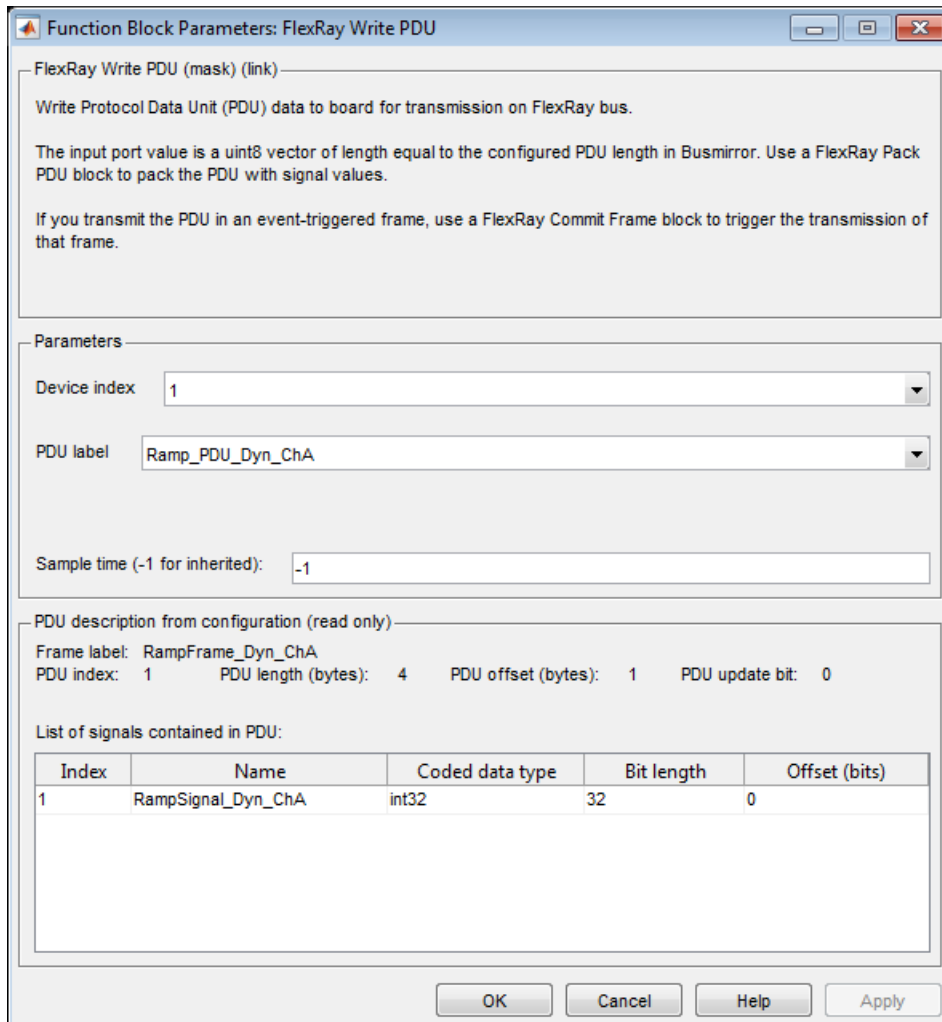

Function Block Parameters: FlexRay Write PDU

FlexRay Write PDU (mask) (link)

Write Protocol Data Unit (PDU) data to board for transmission on FlexRay bus.

The input port value is a uint8 vector of length equal to the configured PDU length in Busmirror. Use a FlexRay Pack PDU block to pack the PDU with signal values.

If you transmit the PDU in an event-triggered frame, use a FlexRay Commit Frame block to trigger the transmission of that frame.

Parameters

Device index: 1

PDU label: Ramp_PDU_Dyn_ChA

Sample time (-1 for inherited): -1

PDU description from configuration (read only)

Frame label: RampFrame_Dyn_ChA
PDU index: 1 PDU length (bytes): 4 PDU offset (bytes): 1 PDU update bit: 0

List of signals contained in PDU:

Index	Name	Coded data type	Bit length	Offset (bits)
1	RampSignal_Dyn_ChA	int32	32	0

OK Cancel Help Apply

- 10 Click **OK**.

Repeat these steps for the block labeled EB5100 - Device 2 Write PDU 'Invert_PDU_ChA'. This block is associated with the Invert_ECU controller, with Device index 2.

Configure FlexRay Commit Frame Block for PDU Access

To commit a frame containing Protocol Data Units (PDUs) in model dFlexRaySimpleExample_PDU, configure the FlexRay Commit Frame block.

- 1 Double-click the block labeled EB5100 - Device 1 Commit Frame 'RampFrame_Dyn_ChA'.
- 2 Set **Device index** to 1.

The frame description fills in with information from the FlexRay configuration file for the Ramp_ECU controller.

- 3 Set **Frame label** to RampFrame_Dyn_ChA.
- 4 Set **Trigger edge** to Either.

This frame is a dynamic frame. Only dynamic frames can have a **Timing** value of event.

- 5 Set **Sample time (-1 for inherited)** to -1.

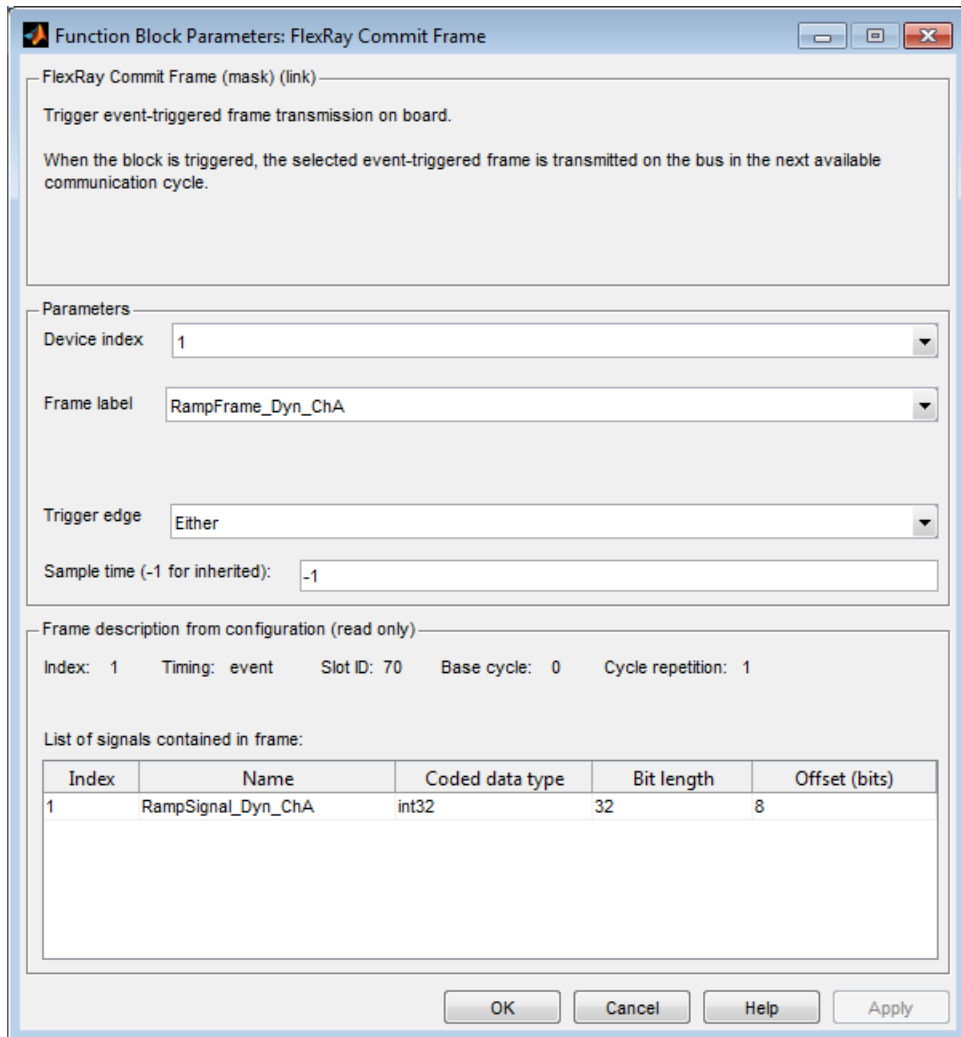

6 Click OK.

Configure FlexRay Read PDU Blocks

To receive a message using FlexRay in model `dFlexRaySimpleExample_PDU`, configure the FlexRay Read PDU blocks.

1 Double-click the block labeled EB5100 - Device 1 Read PDU 'Invert_PDU_ChA'.

2 Set **Device index** to 1.

The PDU description fills in with information from the FlexRay configuration file for the Ramp_ECU controller.

3 Set **PDU label** to Invert_PDU_ChA.

4 Clear the **Enable update status output port** and the **Enable update bit output port** check boxes.

5 Set **Sample time (-1 for inherited)** to -1.

Function Block Parameters: FlexRay Read PDU

FlexRay Read PDU (mask) (link)

Receive Protocol Data Unit (PDU) data from board.

The output port value is a uint8 vector of length equal to the configured PDU length in Busmirror. The PDU data represents signal values in coded data type. Use a FlexRay Unpack PDU block to unpack the PDU into signals.

If you enable the update status output port, when the new data received from the network updates the PDU content, the update status port output value becomes true.

If you define an update bit for the PDU in the configuration and the update bit output port is enabled, when data with the update bit set is received from the board, the update bit output value becomes true. Only when PDU content is received from the board with the update bit unset is the update bit value cleared.

Parameters

Device index: 1

PDU label: Invert_PDU_ChA

Enable update status output port Enable update bit output port

Sample time (-1 for inherited): -1

PDU description from configuration (read only)

Frame label: InvertFrame_ChA
PDU index: 2 PDU length (bytes): 10 PDU offset (bytes): 0 PDU update bit: 80

List of signals contained in PDU:

Index	Name	Coded data type	Bit length	Offset (bits)
3	InvertSignal_Dyn_ChA	int32	32	40
2	InvertSignal_ChA	int32	32	0

OK Cancel Help Apply

6 Click **OK**.

Repeat these steps for the blocks labeled EB5100 - Device 2 Read PDU 'Ramp_PDU_ChA' and EB5100 - Device 2 Read PDU 'Ramp_PDU_Dyn_ChA'. These blocks are associated with the Invert_ECU controller, with **Device index 2**.

Configure FlexRay Unpack PDU Blocks

To unpack signals from FlexRay Protocol Data Units (PDUs) in model dFlexRaySimpleExample_PDU, configure the FlexRay Unpack PDU blocks.

- 1** Double-click the block labeled EB5100 - Device 1 Unpack PDU 'Invert_PDU_ChA'.
- 2** Set **Device index** to 1.

The PDU description fills in with information from the FlexRay configuration file for the Ramp_ECU controller.

- 3** Set **PDU label** to Invert_PDU_ChA.
- 4** Set **Sample time (-1 for inherited)** to -1.

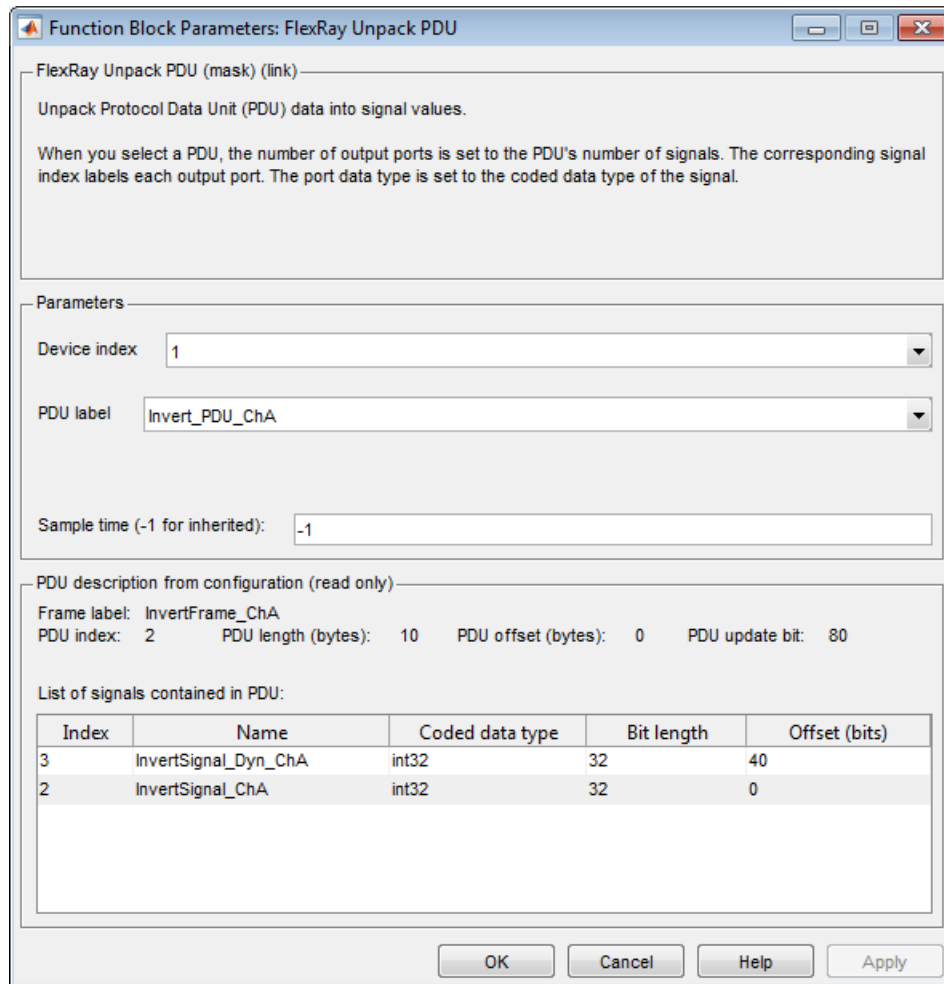

5 Click **OK**.

Repeat these steps for the blocks labeled EB5100 - Device 2 Unpack PDU 'Ramp_PDU_ChA' and EB5100 - Device 2 Unpack PDU 'Ramp_PDU_Dyn_ChA'. These blocks are associated with the Invert_ECU controller, with **Device index 2**.

Configure FlexRay POC Status Blocks for PDU Access

To monitor the functioning of the FlexRay network in model `dFlexRaySimpleExample_PDU`, configure the FlexRay POC Status blocks.

- 1 Double-click the block labeled `EB5100 - Device 1 Read POC state`.
- 2 Set **Device index** to 1.
- 3 Set **Sample time (-1 for inherited)** to -1.
- 4 Click **OK**.

Repeat these steps for the block labeled `EB5100 - Device 2 Read POC state`. This block is associated with the `Invert_ECU` controller, with **Device index 2**.

Configure FlexRay Model Configuration Parameters for PDU Access

FlexRay is a time-triggered protocol. To synchronize the model with the FlexRay communication cycle, in the Configuration Parameters dialog box, specify a time trigger generated by the FlexRay board. To configure model `dFlexRaySimpleExample_PDU` for synchronous operation, perform the following steps.

- 1 In the Configuration Parameters dialog box, expand the **Code Generation** node and then the **Simulink Real-Time Options** node.
- 2 Clear the **Use default communication timeout** check box.
- 3 Calculate $25 \text{ seconds} * \# \text{ of FlexRay boards}$. Type this value into the box **Specify the communication timeout in seconds**.

This value is an estimate of the time required to download the configuration data into the flash memory for the FlexRay boards.

- 4 In the **Execution mode** list, select **Real-Time**.
- 5 In the **Real-time interrupt source** list, select **Auto (PCI only)**.
- 6 In the **I/O board generating the interrupt** list, select **Busmirror EB5100**.
- 7 Take the defaults for the other configuration parameters.

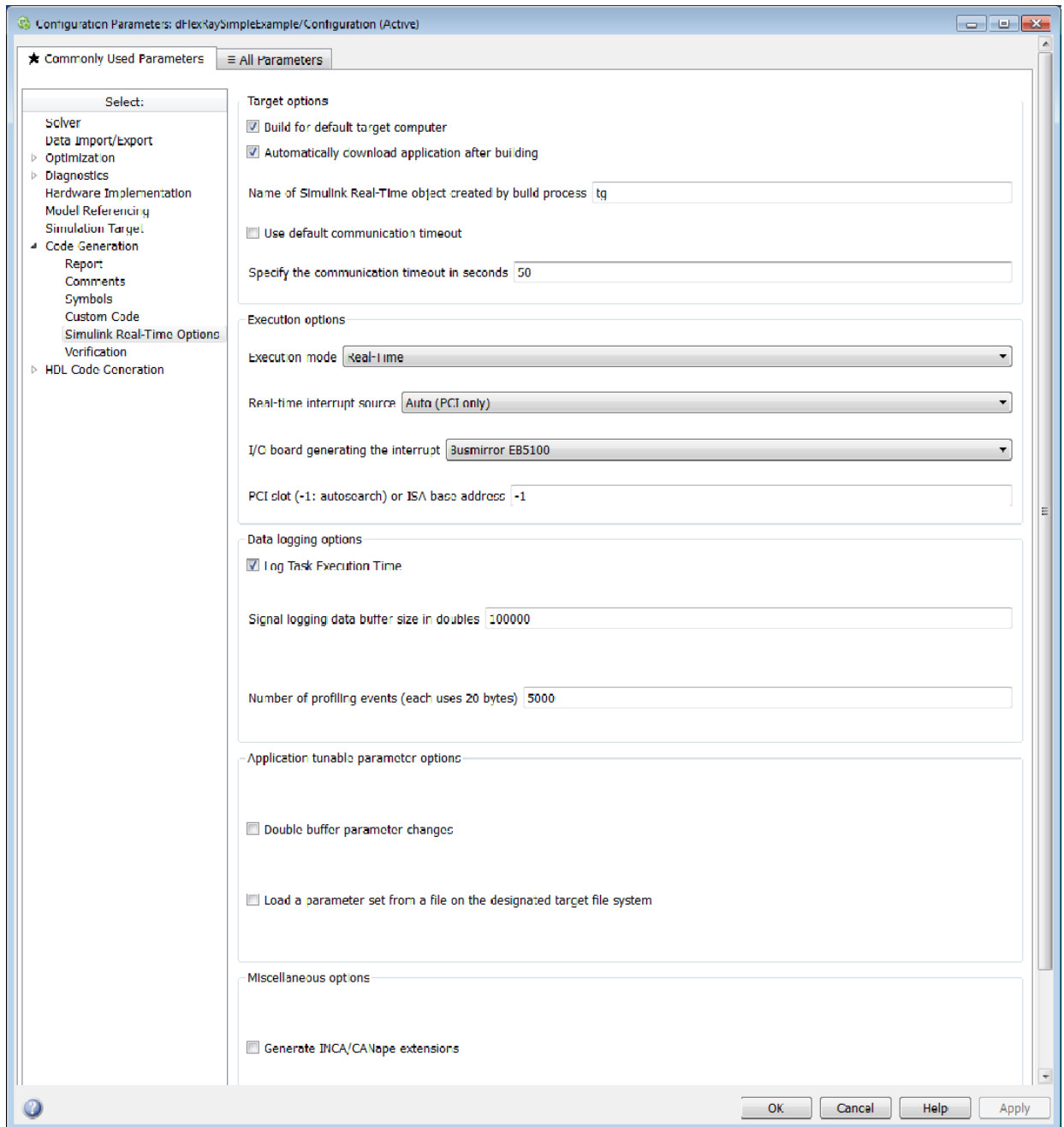

8 Click **OK**.

The next tasks are to build, download, and execute the model.

The FlexRay libraries are licensed. For the first build of a FlexRay model, specify the folder where the license file resides. If you hold a floating license, specify the address of the license server.

Configure FlexRay Node for Error Injection

In this section...

“Create Busmirror Project for Error Injection” on page 35-57

“Select FlexRay Node for Error Injection” on page 35-60

“Refine FlexRay Node for Error Injection” on page 35-60

“Generate Project Code for Error Injection” on page 35-61

To configure a FlexRay node, first install the EB tresos Busmirror configuration software and one or more FlexRay boards in your target computer. See “Install FlexRay Network and Configuration Software” on page 35-2.

This procedure configures the FlexRay network for model `dFlexRaySimpleExample_ErrorInjection`. This model consists of two FlexRay nodes, `Ramp_ECU` and `Invert_ECU`. A FlexRay node corresponds to a FlexRay board, so install two FlexRay boards in your target computer. Create a separate project for each FlexRay node.

The following procedure configures node `Ramp_ECU`.

Repeat these steps for node `Invert_ECU`.

Create Busmirror Project for Error Injection

The following procedure uses the `Ramp_ECU` node of model `dFlexRaySimpleExample_ErrorInjection` as an example. The required FlexRay configuration file is:

```
matlab\toolbox\rtw\targets\xpc\xpcdemos\  
FlexRayConfigFiles\ClusterConfig\FlexRayRampDemo_Signals.xml
```

- 1 Open EB tresos Busmirror in your working folder, for example `C:\workdir`.
- 2 To create a Busmirror project for node `Ramp_ECU`, in the **Manage Projects** tab, click **New Project**.
- 3 In the **Templates** list, select `GenericRBS`.
- 4 In the **Name** text box, enter a name for the node, for example `ramp_ecu`.

- 5** To fill the **Location** text box, navigate to **C:\workdir**.
- 6** Click **Next**.
- 7** To fill the **Select file to import** text box, navigate to and select the required FlexRay configuration file.
- 8** Select the **Copy input file to 'cfg_in' directory** check box.
- 9** Click **Finish**.

The software copies the input file to the 'cfg_in' folder and import FIBEX-format data from the input file. The Busmirror window looks like this figure.

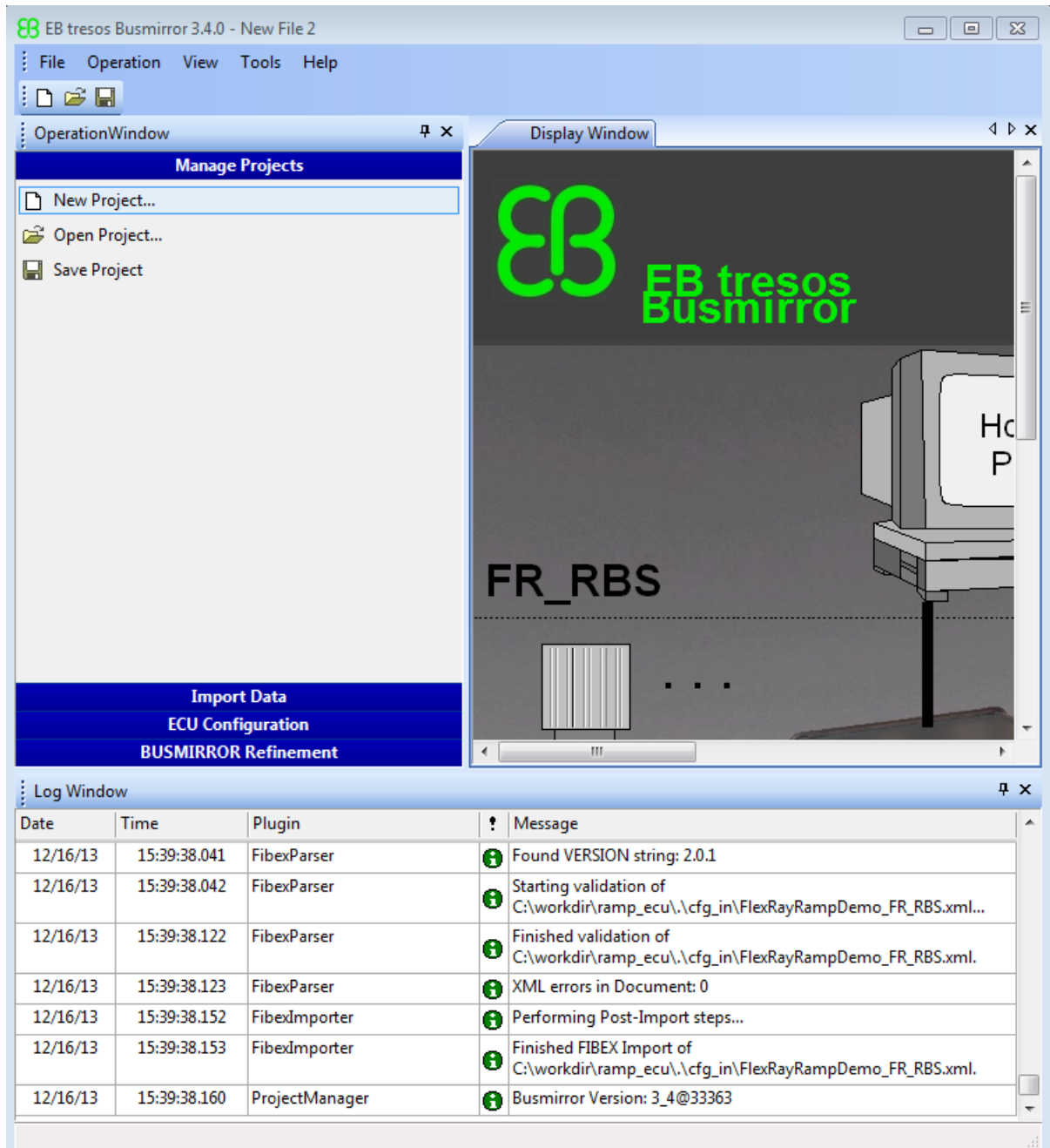

10 In the **Manage Projects** tab, click **Save Project**.

This procedure uses a configuration file specialized for this example. Template configuration files in **FIBEX** format (.xml) and **BOR** format (.bor) are supplied with the EB tresos Busmirror installation. They are stored in the **Examples** folder under the EB \tresos_Busmirror folder.

To create a custom configuration file, use a separate tool such as SIMTOOLS (available from www.speedgoat.ch).

If you have a custom configuration file in FIBEX format, open the **Import Data** tab and use **Import from FIBEX** to import the configuration data. This process replaces the configuration data imported while you created the project with new data from the FIBEX file.

Select FlexRay Node for Error Injection

The following procedure assumes that you have already created an EB tresos Busmirror project for node Ramp_ECU.

- 1 Open EB tresos Busmirror in your working folder, C:\workdir.
- 2 To configure the Ramp_ECU node, in the **ECU Configuration** tab, select **FlexRay ECU Distribution**.
- 3 In the **Real Controllers** list, select Ramp_ECU.

For this model, you can configure only one FlexRay node (board) per project file. In general, you can select and emulate multiple real controllers on one EB5100 FlexRay board, for example to perform RestBus simulation (RBS).

- 4 Click the **Arrow** button >.
- 5 Click **Finish**.
- 6 In the **Manage Projects** tab, click **Save Project**.

Refine FlexRay Node for Error Injection

The following procedure assumes that you have already created and saved an EB tresos Busmirror project for node Ramp_ECU. If you can use the EB tresos Busmirror project for node Ramp_ECU as it is, you can skip this step.

- 1 Open EB tresos Busmirror in your working folder, C:\workdir.

- 2 To configure the Ramp_ECU node, in the **BUSMIRROR Refinement** tab, select **Signals**.
- 3 In the **Signal** list, click RampSignal_Dyn_ChA.
- 4 In the box for property InvalidValue, check that the value is -1000.

To change this value, type the required value into the box.

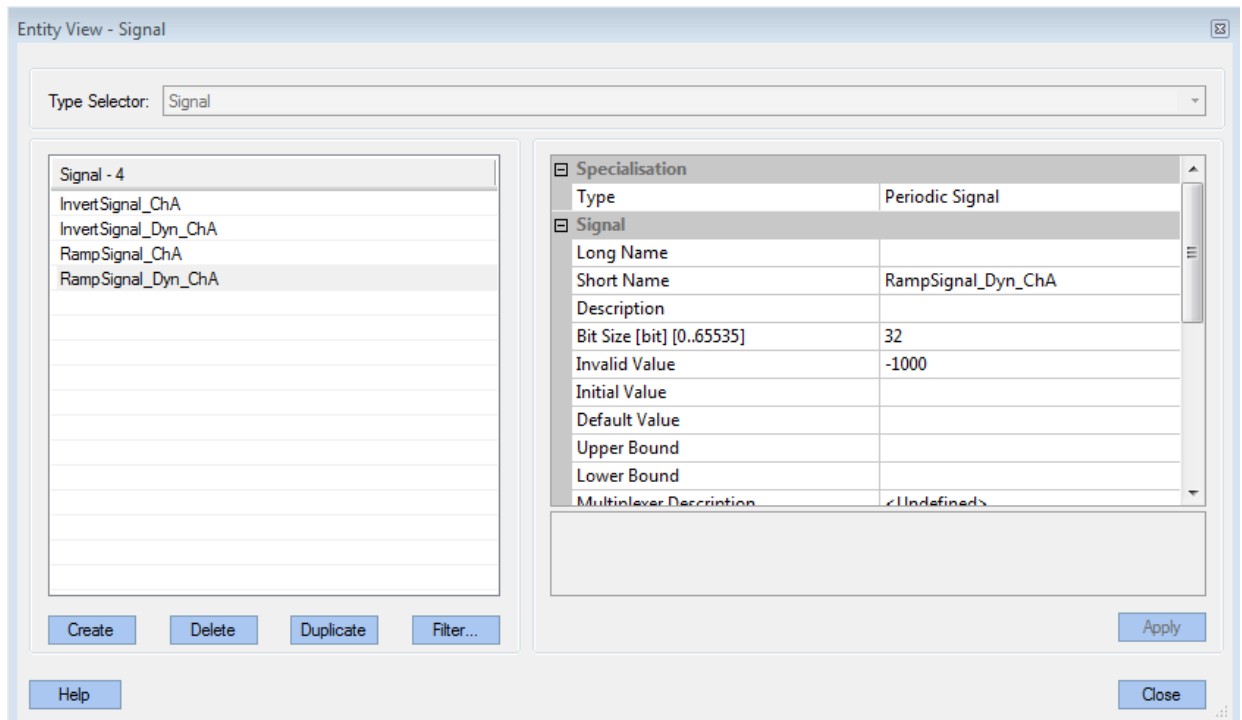

- 5 Click **Apply** and then **Close**.
- 6 In the **Manage Projects** tab, click **Save Project**.

Generate Project Code for Error Injection

The following procedure assumes that you have already selected and configured the EB tresos Busmirror project Ramp_ECU.

- 1 Open EB tresos Busmirror in your working folder, C:\workdir.

- 2 To generate code for the Ramp_ECU node, in the **ECU Configuration** tab, select **Code Generation**.
- 3 In the **Busmirror Generator** dialog box, clear the **Compile for EB2100 Platform** and **Compile for EB6100 Platform** check boxes.

Verify that the **Generate Code** check box is selected and that the **Start communication automatically** check box is cleared.

- 4 Click **Start Process**.

After code generation is complete, the dialog box looks like this figure.

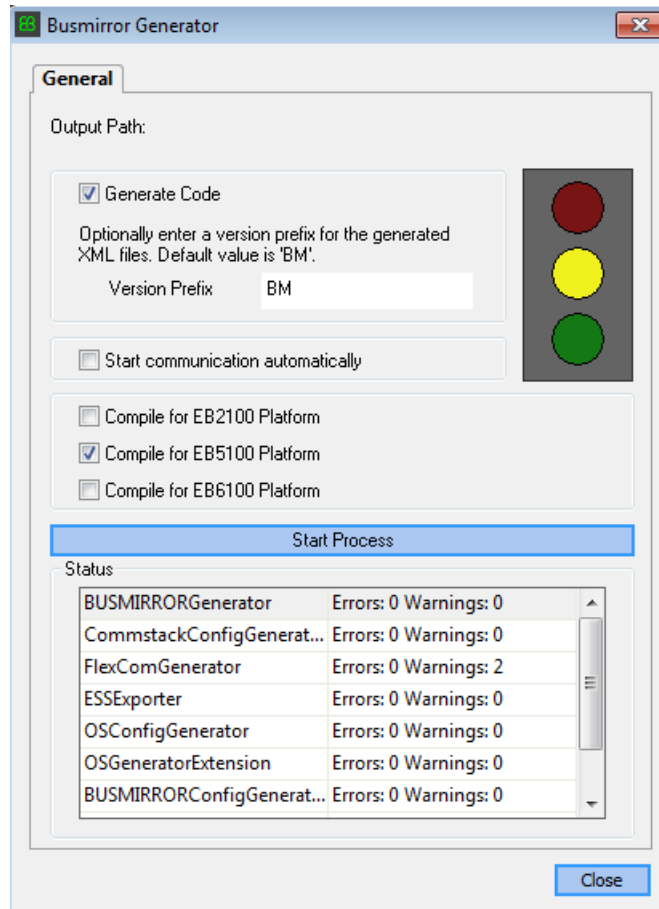

EB tresos Busmirror generates code in the project folder and subfolders.

To modify the generated code, run Busmirror, change the Busmirror configuration, and rebuild the project. Do not hand-modify the project files.

- 5** Click **Close**.
- 6** In the **Manage Projects** tab, click **Save Project**.

At the end of the build procedure, the Busmirror window looks like this figure.

EB tresos Busmirror 3.4.0 - C:\workdir\ramp_ecu\cfg_in\FrCanRBSFR_RBS.bor

File Operation View Tools Help

OperationWindow Display Window

Manage Projects

- New Project...
- Open Project...
- Save Project

Import Data
ECU Configuration
BUSMIRROR Refinement

Home

ECU Configuration

Once a system definition file has been [imported](#) the busmirror configuration can be created. Click on *Busmirror Configurator* within the Operation Window to open the *Busmirror Configurator* dialog. The *Busmirror Configurator* is used to specify the cluster to be emulated by the busmirror. For any details please refer to the user manual.

Remark: During configuration the data of the emulated ECUs will be replaced by busmirror's configuration data. The configuration process may take several minutes.

Switch to the [Busmirror Refinement](#) tab in order to review and modify the created busmirror configuration data.

To generate and compile the busmirror configuration

Log Window

Date	Time	Plugin	Message
12/16/13	16:02:42.782	Loader	"MAKE: Compiling cfg/JobDispFrCfg.c ..."
12/16/13	16:02:42.899	Loader	"MAKE: Compiling src/TUM_SignalManipCfg.c ..."
12/16/13	16:02:43.114	Loader	"MAKE: Creating obj/arch_eb5100/Firmware_debug.elf ..."
12/16/13	16:02:44.531	Loader	"MAKE: Creating obj/arch_eb5100/Firmware.elf ..."
12/16/13	16:02:44.640	Loader	"MAKE: Generating file obj/arch_eb5100/Firmware.ttc ..."
12/16/13	16:02:44.640	Loader	INFO: Build status for EB5100: OK
12/16/13	16:05:24.424	MenuWindow	Writing File: C:\workdir\ramp_ecu\cfg_in\FrCanRBSFR_RBS.bor ...
12/16/13	16:05:24.531	MenuWindow	File written. Get Memento: 0.083 s, Write File: 0.022 s, Total: 0.105 s.
12/16/13	16:05:24.531	MenuWindow	File version history: 4.4.1

Repeat these steps for node `Invert_ECU`.

The next task is “Prepare FlexRay Network for Error Injection” on page 35-66.

Prepare FlexRay Network for Error Injection

To prepare the FlexRay network for execution, as required by your network, do the following steps.

- 1** Connect FlexRay cables to the channel A and B connectors on the Elektrobit EB5100 cards.

By default, cables from channel A connectors on one board connect to channel A connectors on another, and similarly for cables from channel B connectors.

- 2** Connect bus terminators to both ends of the A and B channels. The A and B channels together form the FlexRay bus.
- 3** Connect FlexRay cables to the FlexRay device.

The next task is “Prepare FlexRay Model for Error Injection” on page 35-67.

Prepare FlexRay Model for Error Injection

In this section...

“Configure FlexRay Config Blocks for Error Injection” on page 35-69

“Configure FlexRay Write Frame Signals Blocks for Error Injection” on page 35-70

“Configure FlexRay Read Frame Signals Blocks for Error Injection” on page 35-75

“Configure FlexRay Error Injection Blocks” on page 35-77

“Configure FlexRay POC Status Blocks for Error Injection” on page 35-81

“Configure FlexRay Model Configuration Parameters for Error Injection” on page 35-81

Ramp_ECU: Sends a static frame and a dynamic frame to Invert_ECU and reads back the received signal values. Periodically sends invalid value of signal in the dynamic frame and sends a null frame for the static frame.

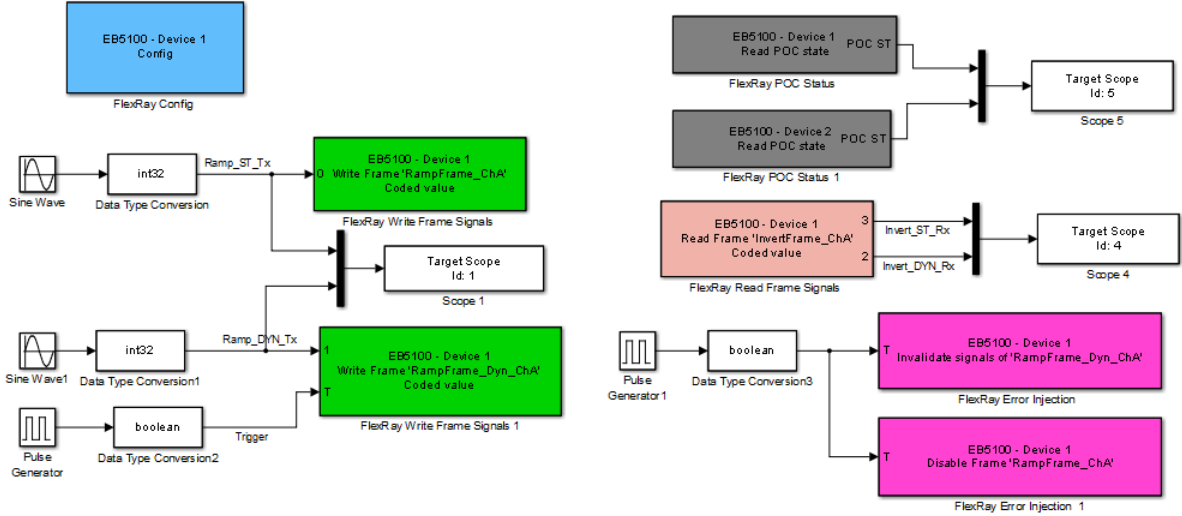

Invert_ECU: Reads frames received from Ramp_ECU and sends them back to Ramp_ECU.

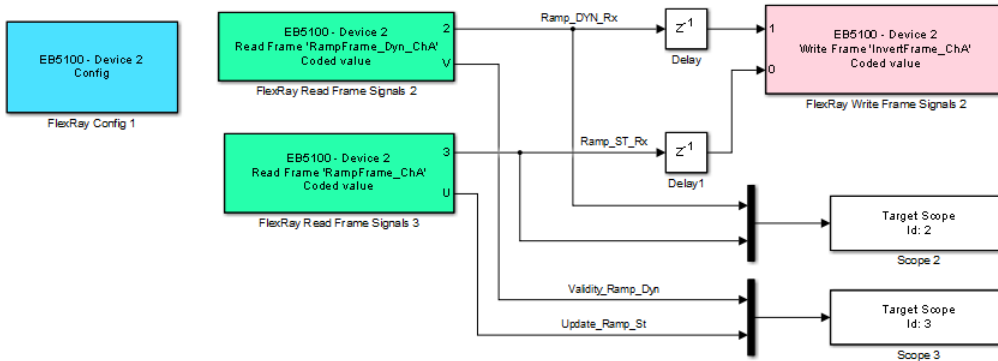

Before configuring model `dFlexRaySimpleExample_ErrorInjection`, record the bus and slot numbers of the FlexRay boards in the target computer and configure each FlexRay node.

To configure model `dFlexRaySimpleExample_ErrorInjection`, perform the following tasks.

Configure FlexRay Config Blocks for Error Injection

To configure the FlexRay Config block for error injection in model `dFlexRaySimpleExample_ErrorInjection`, execute the following steps.

- 1** Double-click the block labeled **EB5100 - Device 1 Config**. This block is the block corresponding to the `Ramp_ECU` controller.
- 2** In text box **Busmirror project file (.bmprj)**, navigate to the project folder for the `Ramp_ECU` controller and click `Project.bmprj`.
- 3** Set the **Join network on simulation start** check box.
- 4** Clear the **Enable board error codes** check box.
- 5** Set **Device index** to 1.
- 6** Type the bus and slot numbers that you recorded while installing the first FlexRay board in text boxes **PCI bus** and **PCI slot**.
- 7** Set **Sample time (-1 for inherited)** to -1.
- 8** Click **Refresh config data** to propagate the changes to the blocks that have **Device index** set to 1.

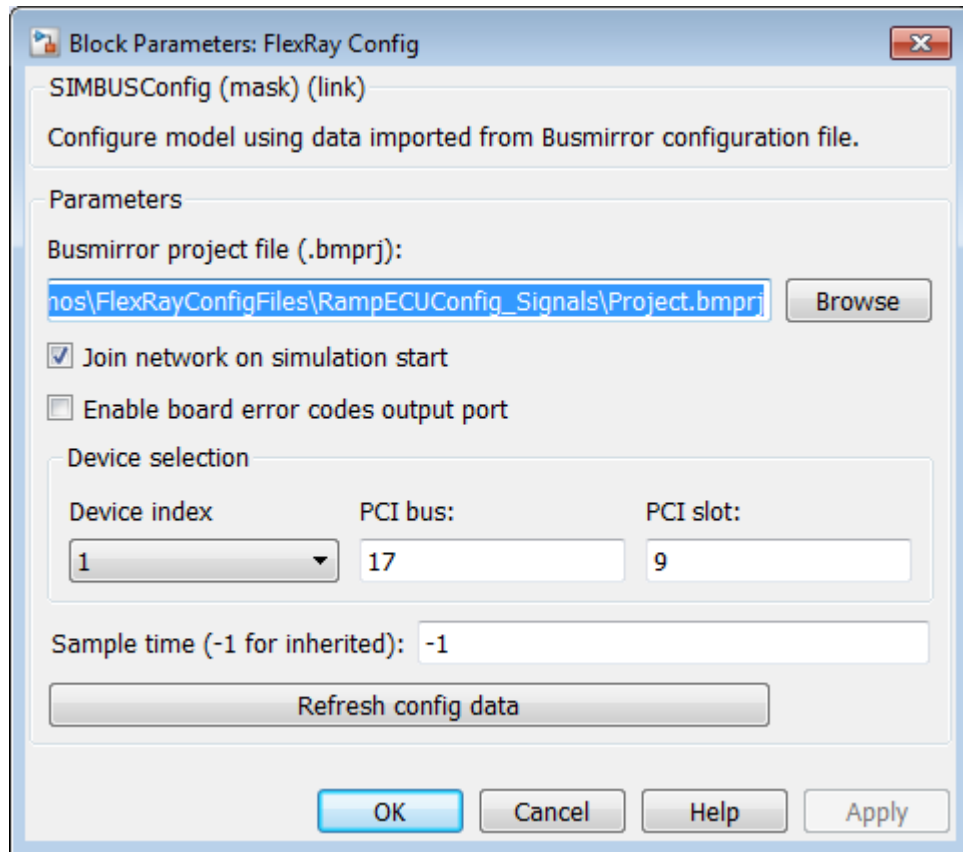

- 9 Click **OK**.

Repeat these steps for the block labeled EB5100 - Device 2 Config. This block is the block that models the `Invert_ECU` controller, with **Device index** 2.

Configure FlexRay Write Frame Signals Blocks for Error Injection

To send a message using FlexRay in model `dFlexRaySimpleExample_ErrorInjection`, configure the FlexRay Write Frame Signals blocks.

1 Double-click the block labeled EB5100 - Device 1 Write Frame 'RampFrame_ChA'.

2 Set **Device index** to 1.

The frame description fills in with information from the FlexRay configuration file for the Ramp_ECU controller.

3 Set **Frame label** to RampFrame_ChA.

This frame is a static frame. You can execute it only with a **Timing** value of **cyclic**. The **Trigger edge** list is disabled.

4 Set **Signals access level** to Coded.

5 Set **Sample time (-1 for inherited)** to -1.

Function Block Parameters: FlexRay Write Frame Signals

FlexRay Write Frame Signals (mask) (link)

Write frame signal values to board for transmission on FlexRay bus.

When you select a frame, the number of input ports is set to the frame's number of signals. The corresponding signal index labels each input port.

When that frame is event-triggered, an additional trigger input port is available. Use this port to trigger sending the frame.

Parameters

Device index: 1

Frame label: RampFrame_ChA

Signals access level: Coded Trigger edge: Rising

Sample time (-1 for inherited): -1

Frame description from configuration (read only)

Index: 0 Timing: cyclic Slot ID: 30 Base cycle: 0 Cycle repetition: 1

List of signals contained in frame:

Index	Name	Coded data type	Bit length	Offset (bits)
0	RampSignal_ChA	int32	32	0

OK Cancel Help Apply

- 6 Click **OK**.
- 7 Double-click the block labeled EB5100 - Device 1 Write Frame 'RampFrame_Dyn_ChA'.
- 8 Set **Device index** to 1.

The frame description fills in with information from the FlexRay configuration file for the Ramp_ECU controller.

- 9** Set **Frame label** to RampFrame_Dyn_ChA.
- 10** Set **Signals access level** to Coded.
- 11** Set **Trigger edge** to Either.

This frame is a dynamic frame. Only dynamic frames can have a **Timing** value of event.

- 12** Set **Sample time (-1 for inherited)** to -1.

Function Block Parameters: FlexRay Write Frame Signals

FlexRay Write Frame Signals (mask) (link)

Write frame signal values to board for transmission on FlexRay bus.

When you select a frame, the number of input ports is set to the frame's number of signals. The corresponding signal index labels each input port.

When that frame is event-triggered, an additional trigger input port is available. Use this port to trigger sending the frame.

Parameters

Device index: 1

Frame label: RampFrame_Dyn_ChA

Signals access level: Coded

Trigger edge: Either

Sample time (-1 for inherited): -1

Frame description from configuration (read only)

Index: 1 Timing: event Slot ID: 70 Base cycle: 0 Cycle repetition: 1

List of signals contained in frame:

Index	Name	Coded data type	Bit length	Offset (bits)
1	RampSignal_Dyn_ChA	int32	32	0

OK Cancel Help Apply

13 Click **OK**.

Repeat these steps for the block labeled EB5100 - Device 2 Write Frame 'InvertFrame_ChA'. This block is associated with the Invert_ECU controller, with **Device index 2**.

Configure FlexRay Read Frame Signals Blocks for Error Injection

To receive a message using FlexRay in model `dFlexRaySimpleExample_ErrorInjection`, configure the FlexRay Read Frame Signals blocks.

1 Double-click the block labeled `EB5100 - Device 1 Read Frame 'InvertFrame_ChA'`.

2 Set **Device index** to 1.

The frame description fills in with information from the FlexRay configuration file for the `Ramp_ECU` controller.

3 Set **Frame label** to `InvertFrame_ChA`.

4 Set **Signals access level** to `Coded`.

5 Clear the **Enable update status output port** and **Enable validity output port** check boxes.

6 Set **Sample time (-1 for inherited)** to -1.

Function Block Parameters: FlexRay Read Frame Signals

FlexRay Read Frame Signals (mask) (link)

Receive frame signal values from board.

When you select a frame, the number of output ports is set to the frame's number of signals. The corresponding signal index labels each output port.

If you enable the update status output port, when all signals are updated, the update status port output value becomes true.

If you enable the validity output port, if an invalid value is received from at least one signal, the validity port output value becomes true.

Parameters

Device index: 1

Frame label: InvertFrame_ChA

Signals access level: Coded

Enable update status output port:

Enable validity output port:

Sample time (-1 for inherited): -1

Frame description from configuration (read only)

Index: 4 Timing: cyclic Slot ID: 50 Base cycle: 0 Cycle repetition: 1

List of signals contained in frame:

Index	Name	Coded data type	Bit length	Offset (bits)
3	InvertSignal_ChA	int32	32	0
2	InvertSignal_Dyn_ChA	int32	32	40

OK Cancel Help Apply

7 Click **OK**.

Repeat these steps for the blocks labeled EB5100 - Device 2 Read Frame 'RampFrame_Dyn_ChA' and EB5100 - Device 2 Read Frame 'RampFrame_ChA'. These blocks are associated with the Invert_ECU controller, with **Device index 2**.

Configure FlexRay Error Injection Blocks

To inject errors into the FlexRay network in model dFlexRaySimpleExample_ErrorInjection, configure the FlexRay Error Injection blocks.

- 1 Double-click the block labeled EB5100 - Device 1 Invalidate signals of 'RampFrame_Dyn_ChA'.
- 2 Set **Device index** to 1.

The frame description fills in with information from the FlexRay configuration file for the Ramp_ECU controller.

- 3 Set **Frame label** to RampFrame_Dyn_ChA.
- 4 Set **Action to perform** to Invalidate signals.
- 5 Set **Sample time (-1 for inherited)** to -1.

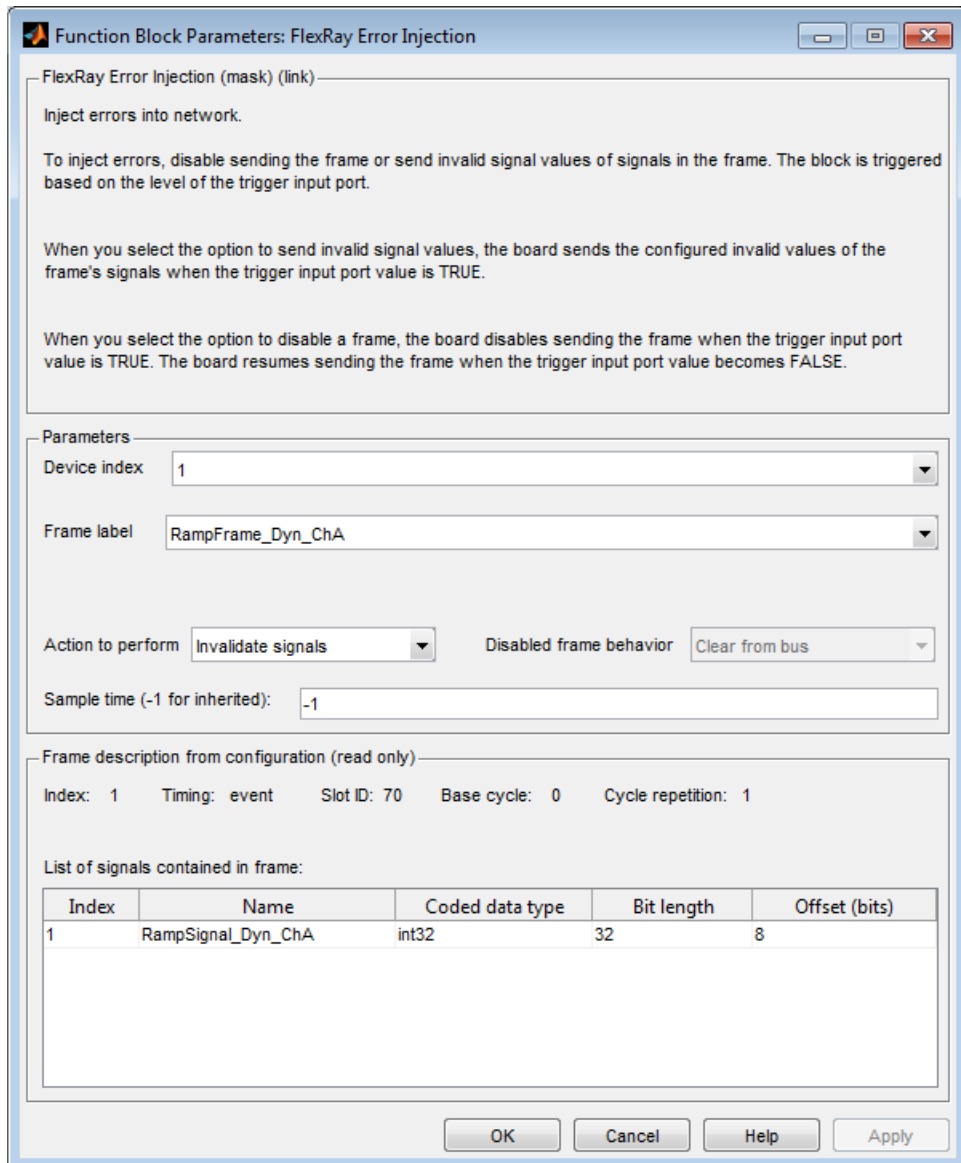

- 6 Click **OK**.

7 Double-click the block labeled EB5100 - Device 1 Disable Frame 'RampFrame_ChA'.

8 Set **Device index** to 1.

The frame description fills in with information from the FlexRay configuration file for the Ramp_ECU controller.

9 Set **Frame label** to RampFrame_ChA.

10 Set **Action to perform** to Disable frame.

11 Set **Disabled frame behavior** to Null frame.

12 Set **Sample time (-1 for inherited)** to -1.

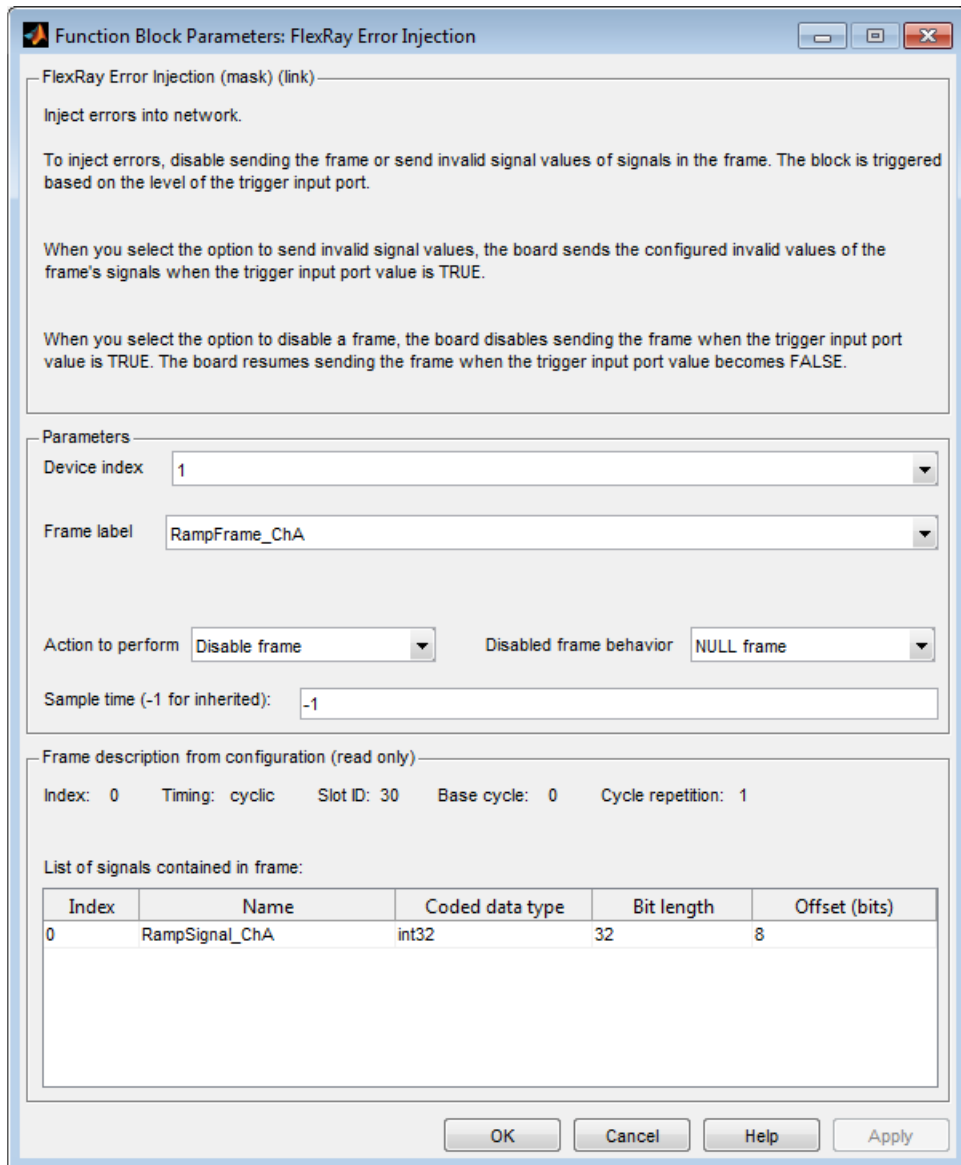

13 Click **OK**.

Configure FlexRay POC Status Blocks for Error Injection

To monitor the functioning of the FlexRay network in model `dFlexRaySimpleExample_ErrorInjection`, configure the FlexRay POC Status blocks.

- 1 Double-click the block labeled `EB5100 - Device 1 Read POC state`.
- 2 Set **Device index** to 1.
- 3 Set **Sample time (-1 for inherited)** to -1.
- 4 Click **OK**.

Repeat these steps for the block labeled `EB5100 - Device 2 Read POC state`. This block is associated with the `Invert_ECU` controller, with **Device index 2**.

Configure FlexRay Model Configuration Parameters for Error Injection

FlexRay is a time-triggered protocol. To synchronize the model with the FlexRay communication cycle, in the Configuration Parameters dialog box, specify a time trigger generated by the FlexRay board. To configure model `dFlexRaySimpleExample_ErrorInjection` for synchronous operation, perform the following steps.

- 1 In the Configuration Parameters dialog box, expand the **Code Generation** node and then the **Simulink Real-Time Options** node.
- 2 Clear the **Use default communication timeout** check box.
- 3 Calculate $25 \text{ seconds} * \# \text{ of FlexRay boards}$. Type this value into the box **Specify the communication timeout in seconds**.

This value is an estimate of the time required to download the configuration data into the flash memory for the FlexRay boards.

- 4 In the **Execution mode** list, select **Real-Time**.
- 5 In the **Real-time interrupt source** list, select **Auto (PCI only)**.
- 6 In the **I/O board generating the interrupt** list, select **Busmirror EB5100**.
- 7 Take the defaults for the other configuration parameters.

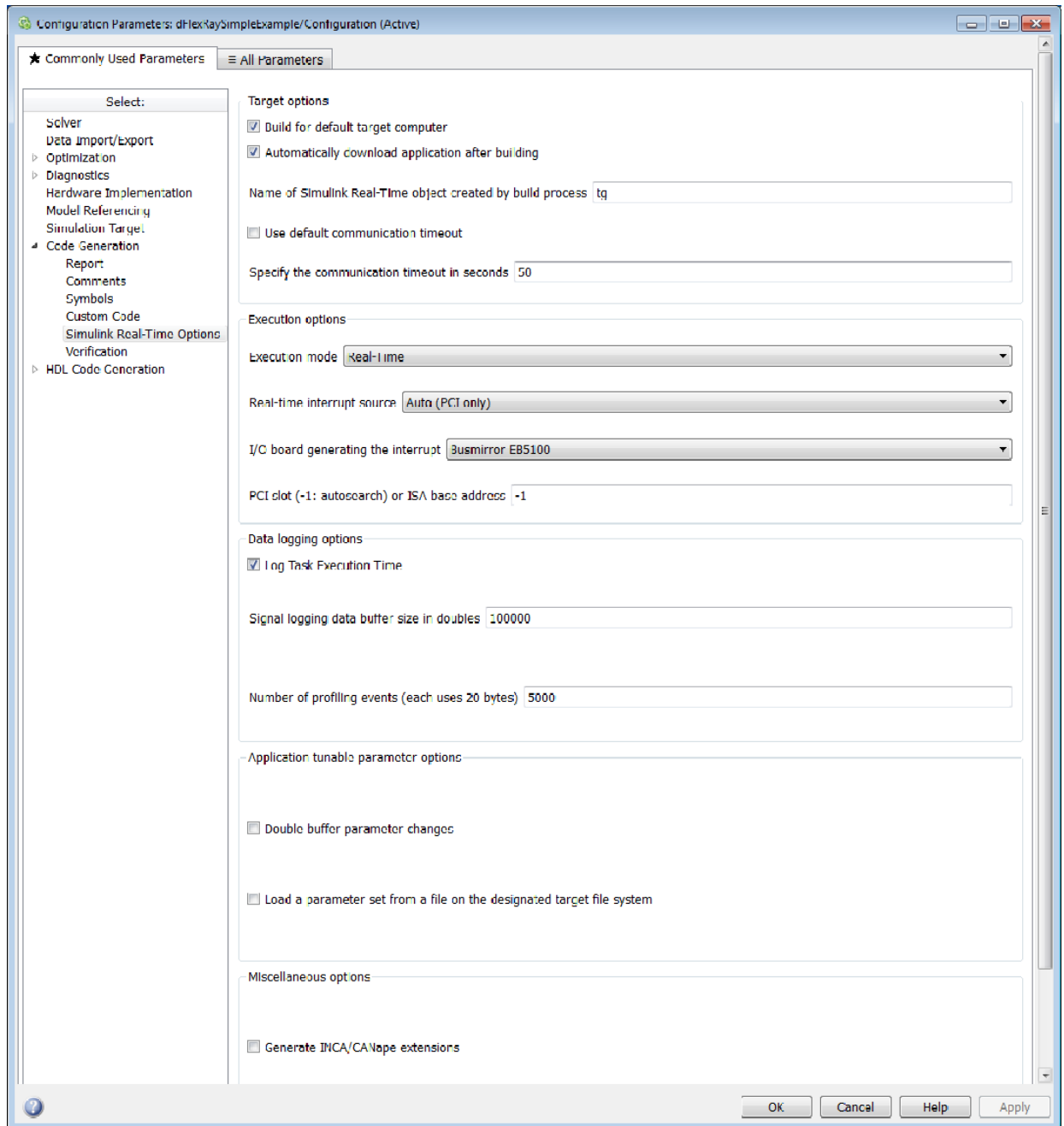

8 Click **OK**.

The next tasks are to build, download, and execute the model.

The FlexRay libraries are licensed. For the first build of a FlexRay model, specify the folder where the license file resides. If you hold a floating license, specify the address of the license server.

Evaluate Clear from Bus Preconditions

You can inject FlexRay disabled-frame errors in two ways: `Clear from bus` and `NULL frame`. You can use `Clear from bus` only if the following preconditions are true:

- You assign the frame triggering to a nonsync slot.
- You assign the frame triggering to a nonzero buffer of the communication controller.

If either precondition is false, use `NULL frame`.

Frame Triggering Assigned to Nonsynchronization Slot

To verify that FlexRay frame triggering is assigned to a nonsynchronization slot:

- 1 Open the EB tresos Busmirror project.
- 2 Expand the **Busmirror Refinement** tab.
- 3 Select **FlexRay Controller Parameters**.
- 4 In the left pane of the **Entity** view, select the FlexRay controller that sends the frame. If you already built the Busmirror project, the two controllers: `BM_ECU_TSL_CC0` and `BM_ECU_TSL_CC1` represent the currently emulated nodes.
- 5 In the communication controller parameters list in the left pane of the **Entity** view, find the parameters `pKeySlotUsedForSync` and `pKeySlotId`. If the value of `pKeySlotUsedForSync` is 1, then slot `pKeySlotId` is a synchronization slot. You cannot disable frame triggering assigned to that slot with `Clear from bus`.
- 6 Close the **Entity** view.
- 7 In the **Busmirror Refinement** tab, select **Frame Scheduler**.
- 8 Select **Frame Triggering** in the static segment section for the frame that you want to disable. If `Slot` is the same as the `pKeySlotId` for which `pKeySlotUsedForSync` is 1, then the frame triggering is assigned to a synchronization slot. Modify the frame triggering slot to a nonsynchronization slot and rebuild the project.

Do these steps for every node in your FlexRay model.

Frame Triggering Assigned to Nonzero Buffer

By default, EB tresos Busmirror assigns one frame to buffer 0, generally the frame with index 0. You cannot use Busmirror to view or change the communication controller buffer to which the frame triggering is assigned.

To change the frame triggering assignment to a nonzero buffer, use SIMTOOLS to manage the communication controller buffers pool. For more information, see the EB Designer Pro documentation that is part of SIMTOOLS, available from Speedgoat (www.speedgoat.ch).

FlexRay Troubleshooting

In this section...

“Model Configuration” on page 35-86

“Build and Download” on page 35-86

“Execution” on page 35-87

FlexRay models have specific troubleshooting requirements during model configuration, build, download, and execution

Model Configuration

- If the EB tresos Busmirror build fails, consult the Busmirror documentation to address the underlying issue. Then, restart the build.
- If a Simulink Real-Time block displays the error message **Block xxx holds an invalid configuration**, verify that you specified the required path in the **Busmirror project file (.bmprj)** text box in the **FlexRay Config** block dialog box. If the file exists at the specified location, in the **FlexRay Config** block dialog box, click **Refresh Config Data**. This action propagates the configuration data to the other blocks with this device index.

Build and Download

- If you see a license checkout error during model build, verify that you properly installed the dongle driver. Also, verify that the license file matches the dongle ID.
- If you see a message similar to this message during model build:

```
'Configuration Parameters > Model Referencing >
  Total number of instances allowed per top model'
  is set to 'Multiple' for model XXX. . . .
```

open the Configuration Parameters dialog box for the FlexRay reference model and expand the **Model Referencing** node. In the **Total number of instances allowed per top model** box, select the value **One**.

If your top-level Simulink model contains more than one reference to the same FlexRay model, restructure the model so that only one reference remains.

- During download, the kernel loads firmware into the FlexRay bus controller, a lengthy process. If you see the error message **Invalid port number**, or if the development and target computers unexpectedly disconnect, the communication between the two computers could be timing out. Check the setting of the **Specify the communication timeout in seconds** text box in the **Simulink Real-Time Options** pane in the Configuration Parameters dialog box.

Try multiplying 25 seconds by the number of FlexRay boards in the model and using that value as the timeout value.

Execution

- During error injection, if you cannot disable a frame using the **Clear from bus** option, verify that you have met the preconditions described in “Evaluate Clear from Bus Preconditions” on page 35-84.
- When a **FlexRay Write PDU** block is triggered and an update bit is defined for the PDU, the PDU is sent with the update bit set. If the PDU frame is scheduled before the next block trigger, the PDU is sent with the update bit cleared until the next block trigger.
- You can use both a **FlexRay Write Frame Signals** block and a **FlexRay Write PDU** block to write the same signal data into the same frame. However, only the content of the PDU is transmitted.
- During error injection, you can use the **Invalidate signals** option to inject an error into a signal that is written using a **FlexRay Write PDU** block. However, the invalid value is not transmitted. To transmit an invalid value, explicitly pack the invalid value into the PDU using the **FlexRay Pack PDU** block.
- You can use the **FlexRay Read PDU** block and the **FlexRay Read Frame Signals** block in the same model to read the signals of the frame that contains the PDU. However, the value of the **Enable update status output port** for the two blocks can be inconsistent from model build to model build. The software indicates the update status by setting the update status port output value for the block that executes first in built execution order. The port output value for the block that executes last remains **false**. The built execution order can change from model build to build.

If you need a consistent result, send the output of both blocks into an **OR Logical Operator** block.

FlexRay Blocks

FlexRay Config

Configure model using data imported from Busmirror configuration file

Library

Simulink Real-Time Library for FlexRay

Description

FlexRay Config imports data from the EB tresos Busmirror configuration file. It initializes the model with the information.

Block Outputs

Name	Description
E	A vector containing three values: [IsErr ErrNum ErrOut]

The error vector persists until the board explicitly changes it, even if the board returned the vector in the previous sample time.

IsErr value 0 denotes normal operation. A nonzero IsErr value denotes an error. The remaining values have meaning only when IsErr is nonzero.

The ErrNum and ErrOut values and the resulting error output are shown in this table.

ErrNum	ErrOut	Error Output
0	0	Unknown error
1	0	Error Queue overrun
2	# (task)	Task # exceeded its time slot
3	# (task)	Task # violated its deadline
4	# (TUM)	Wrong parameters in registering TUM #

ErrNum	ErrOut	Error Output
5	# (TUM)	TUM id # duplicated
6	# (error)	Fatal error occurred on board: #
7	# (task)	FlexRay task at # violated its deadline
8	# (cycles)	Detected a communication cycle shift of # cycles
10	# (index)	Invalid id #
12	# (error)	Target returned error #
14	# (frame)	Cannot send timed FlexRay frame (id #): table full
15	# (packets)	Lost # packets from target device due to overload

- ErrNum values 4 and 5 occur only if the customer added a custom TUM to the firmware.
- ErrNum value 7 occurs when a FlexRay task (Rx or Tx) misses its deadline. The deadline for a Tx task is its slot. The deadline for an Rx task is its slot in the next cycle minus a configurable delay.
- ErrNum value 8 occurs when the FlexRay dispatcher is not called in time.
- ErrNum value 10 occurs when the Target Access Library (TAL) on the target computer tries to process an index representing a nonexistent signal, PDU, or frame.
- ErrNum value 12 occurs when the board returns a value of type `TAL_ReturnType` other than `TAL_Success`.
- ErrNum value 14 occurs when the table used to store FlexRay frames is full.
- ErrNum value 15 occurs when the Tx TAL queue to the target computer overflows

Block Parameters

Busmirror project file (.bmprj)

Type or browse to the location of the Busmirror project file for this network. You can specify either a full path or a relative path to the Busmirror project file.

Enter a value in this parameter. To update the blocks in the model with the updated data, click **Refresh config data**.

Join network on simulation start

If selected, the board joins the FlexRay network when the model starts executing.

If not selected, use a FlexRay Join/Leave Network block to join the network.

Enable board error codes output port

If selected, the block reveals the error output, E.

Device index

Unique value representing this network node.

PCI bus

Bus number of the FlexRay board in the target computer.

PCI slot

Slot number of the FlexRay board in the target computer.

If only one board of this type is in the target computer, enter -1 to locate the board.

Sample time (-1 for inherited)

Enter the base sample time or a multiple of the base sample time.

External Websites

- www.iso.org
- www.elektrobit.com

FlexRay Commit Frame

Trigger event-triggered frame transmission on board

Library

Simulink Real-Time Library for FlexRay

Description

When you trigger the block, the selected event-triggered frame is transmitted on the bus in the next available communication cycle.

Block Inputs

Name	Description
T	Trigger for committing the frame.

Block Parameters

Device index

Unique value representing this network node.

Frame label

Selects a particular frame defined in the EB tresos Busmirror configuration file.

Trigger edge

Event trigger edge. Possible values are **Rising**, **Falling**, and **Either**.

Sample time (-1 for inherited)

Enter the base sample time or a multiple of the base sample time.

External Websites

- www.iso.org

- www.elektrobit.com

FlexRay Join/Leave Network

Define board behavior when join/leave trigger event occurs

Library

Simulink Real-Time Library for FlexRay

Description

This block causes the board to join or leave the network on a trigger event.

When the block is triggered, there are three cases:

- If the board is connected to a physical network that has already started, the board can join or leave the network.
- If the board is connected to a physical network that has not started, there are two cases:
 - If the board is a cold-start node in the network, the board can start and join the network.
 - Otherwise, the board can wait for the network to start.
- If the board is emulating a network, the board can start or stop the network.

Block Inputs

Name	Description
Trigger	Provides trigger event for joining and leaving the network.

Block Parameters

Device index

Unique value representing this network node.

Perform action

Action to take on receiving the trigger event. Possible values are `Join network` and `Leave network`.

Trigger edge

Event trigger edge. Possible values are `Rising`, `Falling`, and `Either`.

Sample time (-1 for inherited)

Enter the base sample time or a multiple of the base sample time.

External Websites

- www.iso.org
- www.elektrobit.com

FlexRay POC Status

Output Protocol Operation Control (POC) state of board

Library

Simulink Real-Time Library for FlexRay

Description

Propagates the FlexRay Protocol Operation Control (POC) state from the board to the output.

The board sends an update of the current POC state to the real-time application every 100 ms.

Block Outputs

Name	Description
POC ST	Number (uint8) that maps to one of the POC states.

The mapping from values to POC states is shown in the following table.

Value	POC State
0	Config — Board is configuring the FlexRay controller with the configuration data provided.
1	Default Config — Board just turned on.
2	Halt — Board has stopped due to a significant error or a request to leave the network. Recovery from this state requires reinitializing the board,

Value	POC State
3	Normal Active — Board is synchronized with the network and sending and receiving data.
4	Normal Passive — Board is handling an error. The board is not synchronized with the network. It can receive data from the bus, but it cannot transmit data to the bus.
5	Ready — Board has finished its initialization sequence and is ready to start a network or join an actively communicating network.
6	Startup — Board is starting the network. Only entered if the board is a cold-start node for the network.
7	Wakeup — Board is initializing and connecting to the network.

Block Parameters

Device index

Unique value representing this network node.

Sample time (-1 for inherited)

Enter the base sample time or a multiple of the base sample time.

External Websites

- www.iso.org
- www.elektrobit.com

FlexRay Error Injection

Inject errors into network

Library

Simulink Real-Time Library for FlexRay

Description

This block injects errors into the network by disabling the sending of a frame or sending invalid signal values to signals in the frame.

To disable sending a frame in the static segment, either send nothing or send a null frame in place of the configured frame.

To send invalid signal values, in the FlexRay configuration file, define an invalid value for each signal in the frame.

Block Inputs

Name	Description
Trigger	Event that starts error injection. When the input signal value is 1, the specified error type is injected into the network. When the input signal value is 0, the error is not injected.

Block Parameters

Device index

Unique value representing this network node.

Frame label

Selects a particular frame defined in the EB tresos Busmirror configuration file. Each frame defines frame attributes and signal attributes, displayed in the section **Frame description from configuration (read only)**. These attributes cannot be changed except by selecting a different frame.

The frame attributes are:

- Index — Unique number that identifies the frame.
- Timing — Frame timing specification, one of `cyclic` (for time-triggered frames) and `event` (for event-triggered frames).
- Slot ID — Identifier of time slot in communication cycle to which frame is assigned.
- Base cycle — Cycle counter value at which frame transmission starts, in range 0–63.
- Cycle repetition — Frame period, in number of cycle units.

The signal attributes are:

- Index — Unique number that identifies the signal.
- Name — Signal name, as specified in Busmirror configuration software.
- Coded data type — Transport-level data type of the signal, as specified in Busmirror configuration software. Only integer types are supported in Simulink Real-Time.
- Bit length — Length of the signal, in bits.
- Offset (bits) — Offset of the signal in the frame, in bits.

Action to perform

Error to inject when the trigger occurs. Possible values are `Disable frame` (the default) and `Invalidate signals`.

The `Disable frame` option is not available if the selected frame is an event-triggered frame.

The `Invalidate signals` option cannot be used if the signal is being transmitted via a PDU.

Disabled frame behavior

Select `Clear from bus` to transmit no frame on the bus and `NULL frame` to transmit a frame with an empty payload (a null frame) on the bus.

When **Action to perform** is set to **Invalidate signals**, this parameter is disabled.

You can use **Clear from bus** only if the following preconditions are both true:

- You assign the frame triggering to a nonsync slot.
- You assign the frame triggering to a nonzero buffer of the communication controller.

Sample time (-1 for inherited)

Enter the base sample time or a multiple of the base sample time.

More About

- “Evaluate Clear from Bus Preconditions” on page 35-84
- “FlexRay Troubleshooting” on page 35-86

External Websites

- www.iso.org
- www.elektrobit.com

FlexRay Pack PDU

Pack Protocol Data Unit (PDU) data with signal values

Library

Simulink Real-Time Library for FlexRay

Description

Packs protocol data unit (PDU) with signal values passed in through the input ports.

When a PDU is selected, the number of input ports is set to the number of signals in the PDU. Each input port is labeled with the corresponding signal index, and its data type is set to the transport data type of the signal.

Block Inputs and Outputs

Inputs

Name	Description
#	Input labeled with number # is input port for signal with index #.

Outputs

Name	Description
#	uint8 vector of length equal to the configured PDU length in EB tresos Busmirror. The label # is the PDU index generated by Busmirror.

Block Parameters

Device index

Unique value representing this network node.

PDU label

Selects a particular PDU defined in the EB tresos Busmirror configuration file. Each PDU defines PDU attributes and signal attributes, displayed in the section **PDU description from configuration (read only)**. These attributes cannot be changed except by selecting a different PDU.

The PDU attributes are:

- Frame label — Label of the frame that contains the PDU.

The configuration file can allocate a PDU to more than one frame. This field contains the label of the first frame encountered by the software in processing the configuration file.

- PDU index — Unique number that identifies the PDU.
- PDU length (bytes) — Number of bytes in the PDU.

Some bytes in the PDU might not be used. Unused bytes have the value 0.

- PDU offset (bytes) — Offset of the PDU in the frame, in bytes.
- PDU update bit — Offset of the update bit in the frame, in bits.

The PDU update bit is not part of the PDU allocation. It can appear anywhere in the frame.

The signal attributes are:

- Index — Unique number that identifies the signal.
- Name — Signal name, as specified in Busmirror configuration software.
- Coded data type — Transport-level data type of the signal, as specified in Busmirror configuration software. Only integer types are supported in Simulink Real-Time.
- Bit length — Length of the signal, in bits.
- Offset (bits) — Offset of the signal in the PDU, in bits.

Sample time (-1 for inherited)

Enter the base sample time or a multiple of the base sample time.

External Websites

- www.iso.org

- www.elektrobit.com

FlexRay Read Cycle Counter

Output value of board communication cycle counter

Library

Simulink Real-Time Library for FlexRay

Description

Reads the communication cycle counter on the board and sends it to output CC.

Block Outputs

Name	Description
CC	Value of cycle counter.

Block Parameters

Device index

Unique value representing this network node.

Sample time (-1 for inherited)

Enter the base sample time or a multiple of the base sample time.

External Websites

- www.iso.org
- www.elektrobit.com

FlexRay Read Frame Signals

Receive frame signal values from board

Library

Simulink Real-Time Library for FlexRay

Description

Reads signal values from the board.

If you enable the update status output port, when all signals are updated, the update status port output value becomes `true`.

If you enable the validity output port, if an invalid value is received from at least one signal, the validity port output value becomes `true`.

Block Outputs

Name	Description
#	Output labeled with number # is output port for signal with index #.
U	Becomes <code>true</code> when all signals have been updated.
V	Becomes <code>true</code> when at least one signal receives an invalid value.

Block Parameters

Device index

Unique value representing this network node.

Frame label

Selects a particular frame defined in the EB tresos Busmirror configuration file. Each frame defines frame attributes and signal attributes, displayed in the section **Frame description from configuration (read only)**. These attributes cannot be changed except by selecting a different frame.

The frame attributes are:

- Index — Unique number that identifies the frame.
- Timing — Frame timing specification, one of **cyclic** (for time-triggered frames) and **event** (for event-triggered frames).
- Slot ID — Identifier of time slot in communication cycle to which frame is assigned.
- Base cycle — Cycle counter value at which frame transmission starts, in range 0–63.
- Cycle repetition — Frame period, in number of cycle units.

The signal attributes are:

- Index — Unique number that identifies the signal.
- Name — Signal name, as specified in Busmirror configuration software.
- Coded data type — Transport-level data type of the signal, as specified in Busmirror configuration software. Only integer types are supported in Simulink Real-Time.
- Bit length — Length of the signal, in bits.
- Offset (bits) — Offset of the signal in the frame, in bits.

Signals access level

Type specification of ports used to access signals. Possible values are **Coded** and **Physical**.

Coded — Type of every signal input port is set to the configured transport data type in EB tresos Busmirror.

Physical — Type of every signal input port is set to **Double**.

Enable update status output port

Select this check box to make the update status port U visible. The value of port U becomes **true** when all of the signals in the frame have been updated with new values received from the network.

Enable validity output port

Select this check box to make the validity port V visible. The value of port V becomes `true` if an invalid value has been received from at least one signal of the frame. When an invalid value is received, the output port of the signal keeps its current value.

Sample time (-1 for inherited)

Enter the base sample time or a multiple of the base sample time.

External Websites

- www.iso.org
- www.elektrobit.com

FlexRay Read PDU

Receive Protocol Data Unit (PDU) data from board

Library

Simulink Real-Time Library for FlexRay

Description

This block reads PDU values from the board. If your model requires signal values from the PDU, connect the output of the `FlexRay Read PDU` to the input of the `FlexRay Unpack PDU` block

Block Outputs

Name	Description
#	<code>uint8</code> vector of length equal to the configured PDU length in EB tresos Busmirror. The label # is the PDU index generated by Busmirror.
U	Becomes <code>true</code> when new PDU content is received from the network.
B	Becomes <code>true</code> when the update bit is set for the PDU in the frame.

Block Parameters

Device index

Unique value representing this network node.

PDU label

Selects a particular PDU defined in the EB tresos Busmirror configuration file. Each PDU defines PDU attributes and signal attributes, displayed in the section **PDU description from configuration (read only)**. These attributes cannot be changed except by selecting a different PDU.

The PDU attributes are:

- Frame label — Label of the frame that contains the PDU.

The configuration file can allocate a PDU to more than one frame. This field contains the label of the first frame encountered by the software in processing the configuration file.

- PDU index — Unique number that identifies the PDU.
- PDU length (bytes) — Number of bytes in the PDU.

Some bytes in the PDU might not be used. Unused bytes have the value 0.

- PDU offset (bytes) — Offset of the PDU in the frame, in bytes.
- PDU update bit — Offset of the update bit in the frame, in bits.

The PDU update bit is not part of the PDU allocation. It can appear anywhere in the frame.

The signal attributes are:

- Index — Unique number that identifies the signal.
- Name — Signal name, as specified in Busmirror configuration software.
- Coded data type — Transport-level data type of the signal, as specified in Busmirror configuration software. Only integer types are supported in Simulink Real-Time.
- Bit length — Length of the signal, in bits.
- Offset (bits) — Offset of the signal in the PDU, in bits.

Enable update status output port

Select this check box to make the update status port U visible. Port U becomes `true` when the PDU has been updated with a new value received from the network.

Enable update bit output port

Select this check box to make the update bit output port B visible. Port B becomes `true` when the update bit is set within the PDU in the frame.

This option is enabled only if the FlexRay configuration file defines an update bit for the PDU.

Reading the PDU does not clear the update bit. Once set, the update bit is cleared only if new PDU content that has the update bit cleared is received from the network.

Sample time (-1 for inherited)

Enter the base sample time or a multiple of the base sample time.

External Websites

- www.iso.org
- www.elektrobit.com

FlexRay Unpack PDU

Unpack Protocol Data Unit (PDU) data into signal values

Library

Simulink Real-Time Library for FlexRay

Description

Unpacks protocol data unit (PDU) into signal values.

Block Inputs and Outputs

Inputs

Name	Description
#	uint8 vector of length equal to the configured PDU length in EB tresos Busmirror. The label # is the PDU index generated by Busmirror.

Outputs

Name	Description
#	Output labeled with number # is output port for signal with index #.

Block Parameters

Device index

Unique value representing this network node.

PDU label

Selects a particular PDU defined in the EB tresos Busmirror configuration file. Each PDU defines PDU attributes and signal attributes, displayed in the section **PDU description from configuration (read only)**. These attributes cannot be changed except by selecting a different PDU.

The PDU attributes are:

- Frame label — Label of the frame that contains the PDU.

The configuration file can allocate a PDU to more than one frame. This field contains the label of the first frame encountered by the software in processing the configuration file.

- PDU index — Unique number that identifies the PDU.
- PDU length (bytes) — Number of bytes in the PDU.

Some bytes in the PDU might not be used. Unused bytes have the value 0.

- PDU offset (bytes) — Offset of the PDU in the frame, in bytes.
- PDU update bit — Offset of the update bit in the frame, in bits.

The PDU update bit is not part of the PDU allocation. It can appear anywhere in the frame.

The signal attributes are:

- Index — Unique number that identifies the signal.
- Name — Signal name, as specified in Busmirror configuration software.
- Coded data type — Transport-level data type of the signal, as specified in Busmirror configuration software. Only integer types are supported in Simulink Real-Time.
- Bit length — Length of the signal, in bits.
- Offset (bits) — Offset of the signal in the PDU, in bits.

Sample time (-1 for inherited)

Enter the base sample time or a multiple of the base sample time.

External Websites

- www.iso.org
- www.elektrobit.com

FlexRay Write Frame Signals

Write frame signal values to board for transmission on FlexRay bus

Library

Simulink Real-Time Library for FlexRay

Description

When triggered, writes signal values to the board for transmission on the FlexRay bus.

When you select a frame, the number of input ports is set to the number of signals associated with the frame. When that frame is event-triggered, an additional trigger input port is available. Use this port to trigger sending the frame.

Block Inputs

Name	Description
#	Input labeled with number # is input port for signal with index #.
T	Trigger for writing signal values. This input port is revealed if the selected frame is an event-triggered frame.

Block Parameters

Device index

Unique value representing this network node.

Frame label

Selects a particular frame defined in the EB tresos Busmirror configuration file. Each frame defines frame attributes and signal attributes, displayed in the section **Frame**

description from configuration (read only). These attributes cannot be changed except by selecting a different frame.

The frame attributes are:

- Index — Unique number that identifies the frame.
- Timing — Frame timing specification, one of `cyclic` (for time-triggered frames) and `event` (for event-triggered frames).
- Slot ID — Identifier of time slot in communication cycle to which frame is assigned.
- Base cycle — Cycle counter value at which frame transmission starts, in range 0–63.
- Cycle repetition — Frame period, in number of cycle units.

The signal attributes are:

- Index — Unique number that identifies the signal.
- Name — Signal name, as specified in Busmirror configuration software.
- Coded data type — Transport-level data type of the signal, as specified in Busmirror configuration software. Only integer types are supported in Simulink Real-Time.
- Bit length — Length of the signal, in bits.
- Offset (bits) — Offset of the signal in the frame, in bits.

Signals access level

Type specification of ports used to access signals. Possible values are `Coded` and `Physical`.

`Coded` — Type of every signal input port is set to the configured transport data type in EB tresos Busmirror.

`Physical` — Type of every signal input port is set to `Double`.

Trigger edge

Event trigger edge. Possible values are `Rising`, `Falling`, and `Either`.

Sample time (-1 for inherited)

Enter the base sample time or a multiple of the base sample time.

External Websites

- www.iso.org
- www.elektrobit.com

FlexRay Write PDU

Write Protocol Data Unit (PDU) data to board for transmission on FlexRay bus

Library

Simulink Real-Time Library for FlexRay

Description

When triggered, writes protocol data to the board for transmission on the FlexRay bus.

This block does not have a dedicated trigger input. If you transmit the PDU in an event-triggered frame, use a `FlexRay Commit Frame` block to trigger the transmission of the frame.

Block Inputs

Name	Description
#	uint vector of length equal to the configured PDU length in EB tresos Busmirror. Use a <code>FlexRay Pack PDU</code> block to pack the PDU with signal values.

Block Parameters

Device index

Unique value representing this network node.

PDU label

Selects a particular PDU defined in the EB tresos Busmirror configuration file. Each PDU defines PDU attributes and signal attributes, displayed in the section **PDU description from configuration (read only)**. These attributes cannot be changed except by selecting a different PDU.

The PDU attributes are:

- Frame label — Label of the frame that contains the PDU.

The configuration file can allocate a PDU to more than one frame. This field contains the label of the first frame encountered by the software in processing the configuration file.

- PDU index — Unique number that identifies the PDU.
- PDU length (bytes) — Number of bytes in the PDU.

Some bytes in the PDU might not be used. Unused bytes have the value 0.

- PDU offset (bytes) — Offset of the PDU in the frame, in bytes.
- PDU update bit — Offset of the update bit in the frame, in bits.

The PDU update bit is not part of the PDU allocation. It can appear anywhere in the frame.

The signal attributes are:

- Index — Unique number that identifies the signal.
- Name — Signal name, as specified in Busmirror configuration software.
- Coded data type — Transport-level data type of the signal, as specified in Busmirror configuration software. Only integer types are supported in Simulink Real-Time.
- Bit length — Length of the signal, in bits.
- Offset (bits) — Offset of the signal in the PDU, in bits.

Sample time (-1 for inherited)

Enter the base sample time or a multiple of the base sample time.

External Websites

- www.iso.org
- www.elektrobit.com

GE Intelligent Platforms Blocks

Simulink Real-Time supports boards manufactured by Abaco, formerly GE Intelligent Platforms and GE Fanuc, which acquired the intellectual property of SBS Technologies, VMIC, and Condor Engineering. See the manufacturer documentation (www.abaco.com).

Condor CEI-520A

Support for ARINC 429 CEI-520A boards.

Board

Condor CEI-520A

General Description

The commercial and aircraft transport industry uses the ARINC 429 protocol. The ARINC-429 driver library allows real-time applications to connect to an ARINC bus network to send and receive 32-bit words. This topic assumes that you are familiar with the ARINC 429 standard.

The Simulink Real-Time software supports the ARINC 429 protocol with the CEI-520A board. This board interfaces a target computer to an ARINC 429 data bus and supports the PCI bus.

The Simulink Real-Time block library provides the following driver blocks to support the CEI-520A board:

- Condor CEI-520A Initialize
- Condor CEI-520A Send
- Condor CEI-520A Receive

Use the following utility blocks to format the data sent to and received from the CEI-520A Send and Receive blocks:

- Condor Encode ARINC 429 Words for Send
- Condor Decode ARINC 429 Words from Receive

Board Characteristics

Board name	CEI-520A
------------	----------

Manufacturer	GE Fanuc (formerly Condor Engineering)
Bus type	PCI
Access method	Memory mapped
Multiple block instance support	Yes
Multiple board support	Yes

External Websites

- www.aviation-ia.com
- www.abaco.com

Condor CEI-520A Initialize

Condor CEI-520A Initialize block

Library

Simulink Real-Time Library for Arinc-429

Note

Your model must include a CEI-520A Initialize block for every physical board in the model. Configure your Send and Receive blocks with the **Board ID** value from this block to identify the physical board to which they refer. This block supports up to 16 unique CEI-520A boards.

Block Parameters

Board ID

From the list, select from 1 to 16 a unique ID for the CEI board. Use the same ID to identify the CEI board in the Initialize, Send, and Receive blocks in your model.

Wrap each send channel to the corresponding receive channel

Select this check box to enable the loopback feature. If you select this block, each word sent over the output channel *n* is received on the input channel *n*.

Timer tick length

Specify the length of a timer tick in .25 microsecond units. The default value is 4000, which results in a tick length of one millisecond. If you select time tags from a Decode ARINC 429 Words from Receive block, the time tags are provided in units of timer ticks.

Sample time

Enter the base sample time or a multiple of the base sample time (-1 means sample time is inherited).

PCI slot (-1:autosearch)

If only one board of this type is in the target computer, enter -1 to locate the board.

If two or more boards of this type are in the target computer, enter the bus number and the PCI slot number of the board associated with this driver block. Use the format **[BusNumber,SlotNumber]**.

To determine the bus number and the PCI slot number, type:

```
tg = slrt;  
getPCIInfo(tg, 'installed')
```

External Websites

- www.aviation-ia.com
- www.abaco.com

Condor CEI-520A Send

Condor CEI-520A Send block

Library

Simulink Real-Time Library for Arinc-429

Note

Use this block to set up one channel of a board to send 32-bit words. The number of channels varies depending on the board you have. You can provide multiple Send blocks for each channel.

Block Parameters

Board ID

From the list, select from 1 to 16 a unique ID for the CEI board. Use the same ID to identify the CEI board in the Initialize, Send, and Receive blocks in your model.

Channel

From the list, select a channel ID. This number varies depending on the particular board that you are using. Refer to your board manufacturer documentation for the number of channels in the board. If you try to select a nonexistent channel, the block returns an error.

Baud rate

From the list, select:

- 12.5 Kbits/sec
- 100 Kbits/sec

Corresponding Send and Receive blocks must have the same baud rate setting for this channel.

Parity

From the list, select:

- odd
- none

Corresponding Send and Receive blocks must have the same parity setting for this channel.

Sample time

Enter the base sample time or a multiple of the base sample time (- 1 means sample time is inherited).

External Websites

- www.aviation-ia.com
- www.abaco.com

Condor CEI-520A Receive

Condor CEI-520A Receive block

Library

Simulink Real-Time Library for Arinc-429

Note

Use this block to set up one channel of a board to receive 32-bit words. The number of channels varies depending on the board you have.

The output port of a Receive block is a signal of type double, but the data on this port is encoded in a nonstandard way. Normally, you should feed this output port into an ARINC Decode block (which converts the data into standard double output). You can also feed it into blocks such as MUX blocks which do not interpret the data. However, before feeding this port into a block such as a Simulink Real-Time Scope block which does interpret the data, you must first pass it through an ARINC Decode block.

Block Parameters

Board ID

From the list, select from 1 to 16 a unique ID for the CEI board. Use the same ID to identify the CEI board in the Initialize, Send, and Receive blocks in your model.

Channel

From the list, select a channel ID. This number varies depending on the particular board that you are using. Refer to your board manufacturer documentation for the number of channels in the board. If you try to select a nonexistent channel, the block returns an error.

Max number of words to return

Enter the maximum number of words to extract from the receive buffer on the I/O module. This number is the maximum number of words for the selected channel at each sample time.

If you select n , the output port of the block has a signal width of $n+1$. The first signal element contains the count of words actually extracted from the buffer during the current sample time.

Min number of words to return

Enter the minimum number of words to extract from the receive buffer on the I/O module. This number is the minimum number of words for the selected channel at each sample time.

If the receive buffer does not contain this minimum number of words for the selected channel during the current sample time, the block does not extract words from the buffer. The word count associated with the output port is then 0.

Baud rate

From the list, select:

- 12.5 Kbits/sec
- 100 Kbits/sec

Corresponding Send and Receive blocks must have the same baud rate setting for this channel.

Parity

From the list, select:

- odd
- none

Corresponding Send and Receive blocks must have the same parity setting for this channel.

Sample time

Enter the base sample time or a multiple of the base sample time (- 1 means sample time is inherited).

External Websites

- www.aviation-ia.com
- www.abaco.com

Condor (GE-IP) RCEI-530

Support for ARINC 429 RCEI-530 and CEI-530 boards

Board

Condor (GE-IP) RCEI-530, Condor (GE-IP) CEI-530

General Description

The commercial and aircraft transport industry uses the ARINC 429 protocol. The ARINC-429 driver library allows real-time applications to connect to an ARINC bus network to send and receive 32-bit words. This topic assumes that you are familiar with the ARINC 429 standard.

The Simulink Real-Time software supports the ARINC 429 protocol with the RCEI-530 and CEI-530 boards. This board type interfaces a target computer to an ARINC 429 data bus and supports the PCI bus.

The Simulink Real-Time block library provides the following driver blocks to support the RCEI-530 and CEI-530 boards:

- Condor (GE-IP) RCEI-530 Initialize
- Condor (GE-IP) RCEI-530 Send
- Condor (GE-IP) RCEI-530 Receive

Use the following utility blocks to format the data sent to and received from the RCEI-530 Send and Receive blocks:

- Condor Encode ARINC 429 Words for Send
- Condor Decode ARINC 429 Words from Receive

Board Characteristics

Board name	RCEI-530, CEI-530
------------	-------------------

Manufacturer	GE Fanuc (formerly Condor Engineering)
Bus type	PCI
Access method	Memory mapped
Multiple block instance support	Yes
Multiple board support	Yes

External Websites

- www.aviation-ia.com
- www.abaco.com

Condor (GE-IP) RCEI-530 Initialize

Condor RCEI-530 Initialize block, Condor CEI-530 Initialize block

Library

Simulink Real-Time Library for Arinc-429

Note

Your model must include a **Condor (GE-IP) RCEI-530 Initialize** block for every physical board in the model. Configure your Send and Receive blocks with the **Board ID** value from this block to identify the physical board to which they refer.

Block Parameters

Board ID

From the list, select from 1 to 16 a unique ID for the CEI board. Use the same ID to identify the CEI board in the Initialize, Send, and Receive blocks in your model. This ID is drawn from a pool shared by the RCEI-530, CEI-530, RCEI-830A, and CEI-830 series boards.

Wrap each send channel to the corresponding receive channel

Select this check box to enable the loopback feature. If you select this block, each word sent over the output channel *n* is received on the input channel *n*.

Timer tick length

Specify the length of a timer tick in .25 microsecond units. The default value is 4000, which results in a tick length of one millisecond. If you select time tags from a Decode ARINC 429 Words from Receive block, the time tags are provided in units of timer ticks.

Sample time

Enter the base sample time or a multiple of the base sample time (-1 means sample time is inherited).

PCI slot (-1:autosearch)

If only one board of this type is in the target computer, enter - 1 to locate the board.

If two or more boards of this type are in the target computer, enter the bus number and the PCI slot number of the board associated with this driver block. Use the format **[BusNumber,SlotNumber]**.

To determine the bus number and the PCI slot number, type:

```
tg = slrt;  
getPCIInfo(tg, 'installed')
```

External Websites

- www.aviation-ia.com
- www.abaco.com

Condor (GE-IP) RCEI-530 Send

Condor RCEI-530 Send block, Condor CEI-530 Send block

Library

Simulink Real-Time Library for Arinc-429

Note

Use this block to set up one channel of a board to send 32-bit words. The number of channels varies depending on the board you have. You can provide multiple Send blocks for each channel.

Block Parameters

Board ID

From the list, select from 1 to 16 a unique ID for the CEI board. Use the same ID to identify the CEI board in the Initialize, Send, and Receive blocks in your model. This ID is drawn from a pool shared by the RCEI-530, CEI-530, RCEI-830A, and CEI-830 series boards.

Channel

From the list, select a channel ID. This number varies depending on the particular board that you are using. Refer to your board manufacturer documentation for the number of channels in the board. If you try to select a nonexistent channel, the block returns an error.

Baud rate

From the list, select:

- 12.5 Kbits/sec
- 100 Kbits/sec

Corresponding Send and Receive blocks must have the same baud rate setting for this channel.

Parity

From the list, select:

- odd
- none

Corresponding Send and Receive blocks must have the same parity setting for this channel.

Sample time

Enter the base sample time or a multiple of the base sample time (- 1 means sample time is inherited).

External Websites

- www.aviation-ia.com
- www.abaco.com

Condor (GE-IP) RCEI-530 Receive

Condor RCEI-530 Receive block, Condor CEI-530 Receive block

Library

Simulink Real-Time Library for Arinc-429

Note

Use this block to set up one channel of a board to receive 32-bit words. The number of channels varies depending on the board you have.

The output port of a Receive block is a signal of type double, but the data on this port is encoded in a nonstandard way. Normally, you should feed this output port into an ARINC Decode block (which converts the data into standard double output). You can also feed it into blocks such as MUX blocks which do not interpret the data. However, before feeding this port into a block such as a Simulink Real-Time Scope block which does interpret the data, you must first pass it through an ARINC Decode block.

Block Parameters

Board ID

From the list, select from 1 to 16 a unique ID for the CEI board. Use the same ID to identify the CEI board in the Initialize, Send, and Receive blocks in your model. This ID is drawn from a pool shared by the RCEI-530, CEI-530, RCEI-830A, and CEI-830 series boards.

Channel

From the list, select a channel ID. This number varies depending on the particular board that you are using. Refer to your board manufacturer documentation for the number of channels in the board. If you try to select a nonexistent channel, the block returns an error.

Max number of words to return

Enter the maximum number of words to extract from the receive buffer on the I/O module. This number is the maximum number of words for the selected channel at each sample time.

If you select n , the output port of the block has a signal width of $n+1$. The first signal element contains the count of words actually extracted from the buffer during the current sample time.

Min number of words to return

Enter the minimum number of words to extract from the receive buffer on the I/O module. This number is the minimum number of words for the selected channel at each sample time.

If the receive buffer does not contain this minimum number of words for the selected channel during the current sample time, the block does not extract words from the buffer. The word count associated with the output port is then 0.

Baud rate

From the list, select:

- 12.5 Kbits/sec
- 100 Kbits/sec

Corresponding Send and Receive blocks must have the same baud rate setting for this channel.

Parity

From the list, select:

- odd
- none

Corresponding Send and Receive blocks must have the same parity setting for this channel.

Sample time

Enter the base sample time or a multiple of the base sample time (- 1 means sample time is inherited).

External Websites

- www.aviation-ia.com

- www.abaco.com

Condor (GE-IP) RCEI-830A

Support for ARINC 429 RCEI-830A and CEI-830 boards

Board

Condor (GE-IP) RCEI-830A, Condor (GE-IP) CEI-830

General Description

The commercial and aircraft transport industry uses the ARINC 429 protocol. The ARINC-429 driver library allows real-time applications to connect to an ARINC bus network to send and receive 32-bit words. This topic assumes that you are familiar with the ARINC 429 standard.

The Simulink Real-Time software supports the ARINC 429 protocol with the RCEI-830A and CEI-830 boards. This board type interfaces a target computer to an ARINC 429 data bus and supports the PCI bus.

The Simulink Real-Time block library provides the following driver blocks to support the RCEI-830A and CEI-830 boards:

- Condor (GE-IP) RCEI-830A Initialize
- Condor (GE-IP) RCEI-830A Send
- Condor (GE-IP) RCEI-830A Receive

Use the following utility blocks to format the data sent to and received from the CEI-830 Send and Receive blocks:

- Condor Encode ARINC 429 Words for Send
- Condor Decode ARINC 429 Words from Receive

Board Characteristics

Board name	RCEI-830A, CEI-830
------------	--------------------

Manufacturer	GE Fanuc (formerly Condor Engineering)
Bus type	PCI
Access method	Memory mapped
Multiple block instance support	Yes
Multiple board support	Yes

External Websites

- www.aviation-ia.com
- www.abaco.com

Condor (GE-IP) RCEI-830A Initialize

Condor RCEI-830A Initialize block, Condor CEI-830 Initialize block

Library

Simulink Real-Time Library for Arinc-429

Note

Your model must include a **Condor (GE-IP) RCEI-830A Initialize** block for every physical board in the model. Configure your Send and Receive blocks with the **Board ID** value from this block to identify the physical board to which they refer.

Block Parameters

Board ID

From the list, select from 1 to 16 a unique ID for the CEI board. Use the same ID to identify the CEI board in the Initialize, Send, and Receive blocks in your model. This ID is drawn from a pool shared by the RCEI-530, CEI-530, RCEI-830A, and CEI-830 series boards.

Wrap each send channel to the corresponding receive channel

Select this check box to enable the loopback feature. If you select this block, each word sent over the output channel *n* is received on the input channel *n*.

Timer tick length

Specify the length of a timer tick in .25 microsecond units. The default value is 4000, which results in a tick length of one millisecond. If you select time tags from a **Decode ARINC 429 Words from Receive** block, the time tags are provided in units of timer ticks.

Sample time

Enter the base sample time or a multiple of the base sample time (- 1 means sample time is inherited).

PCI slot (-1:autosearch)

If only one board of this type is in the target computer, enter - 1 to locate the board.

If two or more boards of this type are in the target computer, enter the bus number and the PCI slot number of the board associated with this driver block. Use the format **[BusNumber,SlotNumber]**.

To determine the bus number and the PCI slot number, type:

```
tg = slrt;  
getPCIInfo(tg, 'installed')
```

External Websites

- www.aviation-ia.com
- www.abaco.com

Condor (GE-IP) RCEI-830A Send

Condor RCEI-830A Send block, Condor CEI-830 Send block

Library

Simulink Real-Time Library for Arinc-429

Note

Use this block to set up one channel of a board to send 32-bit words. The number of channels varies depending on the board you have. You can provide multiple Send blocks for each channel.

Block Parameters

Board ID

From the list, select from 1 to 16 a unique ID for the CEI board. Use the same ID to identify the CEI board in the Initialize, Send, and Receive blocks in your model. This ID is drawn from a pool shared by the RCEI-530, CEI-530, RCEI-830A, and CEI-830 series boards.

Channel

From the list, select a channel ID. This number varies depending on the particular board that you are using. Refer to your board manufacturer documentation for the number of channels in the board. If you try to select a nonexistent channel, the block returns an error.

Baud rate

From the list, select:

- 12.5 Kbits/sec
- 100 Kbits/sec

Corresponding Send and Receive blocks must have the same baud rate setting for this channel.

Parity

From the list, select:

- odd
- none

Corresponding Send and Receive blocks must have the same parity setting for this channel.

Sample time

Enter the base sample time or a multiple of the base sample time (- 1 means sample time is inherited).

External Websites

- www.aviation-ia.com
- www.abaco.com

Condor (GE-IP) RCEI-830A Receive

Condor RCEI-830A Receive block, Condor CEI-830 Receive block

Library

Simulink Real-Time Library for Arinc-429

Note

Use this block to set up one channel of a board to receive 32-bit words. The number of channels varies depending on the board you have.

The output port of a Receive block is a signal of type double, but the data on this port is encoded in a nonstandard way. Normally, you should feed this output port into an ARINC Decode block (which converts the data into standard double output). You can also feed it into blocks such as MUX blocks which do not interpret the data. However, before feeding this port into a block such as a Simulink Real-Time Scope block which does interpret the data, you must first pass it through an ARINC Decode block.

Block Parameters

Board ID

From the list, select from 1 to 16 a unique ID for the CEI board. Use the same ID to identify the CEI board in the Initialize, Send, and Receive blocks in your model. This ID is drawn from a pool shared by the RCEI-530, CEI-530, RCEI-830A, and CEI-830 series boards.

Channel

From the list, select a channel ID. This number varies depending on the particular board that you are using. Refer to your board manufacturer documentation for the number of channels in the board. If you try to select a nonexistent channel, the block returns an error.

Max number of words to return

Enter the maximum number of words to extract from the receive buffer on the I/O module. This number is the maximum number of words for the selected channel at each sample time.

If you select n , the output port of the block has a signal width of $n+1$. The first signal element contains the count of words actually extracted from the buffer during the current sample time.

Min number of words to return

Enter the minimum number of words to extract from the receive buffer on the I/O module. This number is the minimum number of words for the selected channel at each sample time.

If the receive buffer does not contain this minimum number of words for the selected channel during the current sample time, the block does not extract words from the buffer. The word count associated with the output port is then 0.

Baud rate

From the list, select:

- 12.5 Kbits/sec
- 100 Kbits/sec

Corresponding Send and Receive blocks must have the same baud rate setting for this channel.

Parity

From the list, select:

- odd
- none

Corresponding Send and Receive blocks must have the same parity setting for this channel.

Sample time

Enter the base sample time or a multiple of the base sample time (- 1 means sample time is inherited).

External Websites

- www.aviation-ia.com

- www.abaco.com

Condor Encode ARINC 429 Words for Send

Encode ARINC 429 Words for Send block

Library

Simulink Real-Time Library for Arinc-429

Note

The output port of an Encode block is a signal of type double. Because the Encode block encodes the data on this port in a nonstandard way, you must send this data to one of the following:

- Condor CEI-520A Send, Condor (GE-IP) RCEI-530 Send, and Condor (GE-IP) RCEI-830A Send blocks — The ARINC Send block accepts data as a double.
- MUX block — The MUX block does not interpret the data. After the MUX block, you can send it to an ARINC Send block.

Block Parameters

Label

Enter a three digit octal number as the label. The label field of each ARINC word sent over the output port will contain this value.

Data type vector

Enter a vector consisting of values between 0 and 3. These values specify the data type. The length of this vector determines the widths of both the input and output ports. The data type determines how the input double value is converted to a corresponding ARINC value, as follows

Type	Interpretation
0	Raw — Cast the input to an unsigned 32-bit integer and output it as an ARINC word without further processing.

Type	Interpretation
1	<p>BNR (two's complement binary notation) — Scale the input by dividing it by the scale vector in the Resolution (BCD) or Scale (BNR) vector parameter. This input value is restricted to the range [- Scale, Scale], resulting in a scaled value in the range [- 1, 1].</p> <p>The driver performs the following on the scaled value:</p> <ol style="list-style-type: none"> 1 Multiplies the scaled value by 2^{18}. 2 Truncates the value to a 19-bit fixed-point integer, then masks it to the number of high-order bits specified by the Bits to send parameter. 3 Shifts the result up 10 bits and inserts them into the 32-bit integer along with the SSM, SDI, and Label parameter values. <p>To place discrete bits into unused positions, construct the 32-bit word and use it with RAW mode instead of the BNR mode.</p>
2	<p>BCD (binary coded decimal) — Cast the input as a signed integer, limit it to the range representable by an ARINC five-character BCD value, and pack it into an ARINC word. and set the required SSM, SDI, and Label parameter values.</p>
3	<p>Discretes — Cast the input as an unsigned 32-bit integer, pack the low order 19 bits of the result into an ARINC word, and set the required SSM, SDI, and Label parameters.</p>

Resolution (BCD) or Scale (BNR) vector

Enter a vector or scalar value as the resolution vector. This value must be a vector of the same length as the **data type vector** . Otherwise, the scalar value is applied to the length of the **data type vector**. The interpretation of this value depends on the data type. The block works with the data types as follows.

Type	Effect
Raw	<p>The block ignores the resolution value. However, you must still include an associated value in the resolution vector.</p>
BNR	<p>The block uses this value as a scale factor. The block divides the input value by the scale. Doing so limits the valid input range to [-Scale, Scale]. Values outside that range will be limited to \pmScale.</p>

Type	Effect
	A 19-bit signed ARINC binary can represent a range from -262,144 to 262,143. If the combination of input signal and resolution produces a value outside this range, the block keeps it within the range.
BCD	<p>The resolution vector specifies, in the same units as the input signal, the value of the least significant digit of the BCD data field to be encoded and sent. For example, if the associated resolution is .01 and the input signal contains the value 3.1415, the output ARINC word will contain the number 314 in its data field, encoded in BCD. Use the same resolution on the receive side to reconstruct 3.14. Resolution is typically a power of 10, but this is not a restriction.</p> <p>The range representable as an ARINC BCD value is -79,999 to 79,999. If the combination of input signal and resolution produces a value outside this range, the block limits it to be within the range.</p>
Discretes	The block ignores the resolution value. However, you must still include an associated value in the resolution vector.

Bits to send (BNR)

Specifies the number of high order bits of the 19-bit scaled input to keep when the value is inserted into the encoded word. The block uses this value for a BNR format input; other formats ignore it. You must include a place in the array of Bits values for each entry in the data type vector array; however, the block uses the value only for BNR.

SDI vector

Enter a vector or scalar value as the SDI vector. This must be a vector of the same length as the **data type vector**. Otherwise, the scalar value is applied to the length of the **data type vector**.

This block interprets the **SDI vector** values as follows:

Type	Effect
Raw	The block ignores the SDI value. However, you must still include an associated value in the resolution vector.

Type	Effect
BNR, BCD, Discretes	If the SDI element is in the range 0 to 3, the block sets the SDI field of the corresponding output word to that value. If an SDI element has a value of -1, the block does not perform SDI processing on the corresponding output word.

SSM vector

Enter a vector or scalar value as the SSM vector. This vector must be a vector of the same length as the **data type vector**. Otherwise, the scalar value is applied to the length of the **data type vector**.

If the SSM element is in the range 0 to 3, the block sets the SSM field of the corresponding output word to that value. If an SSM element has a value of -1, the block does not perform SSM processing on the corresponding output word. The meaning of a given SSM value differs depending on the data type of the ARINC word.

Type	Effect
Raw	The block ignores the SSM value. However, you must still include an associated value in the resolution vector.
BNR, BCD, Discretes	If the SSM element is in the range 0 to 3, the block sets the SSM field of the corresponding output word to that value. If an SSM element has a value of -1, the block does not perform SSM processing on the corresponding output word.

External Websites

- www.aviation-ia.com
- www.abaco.com

Condor Decode ARINC 429 Words from Receive

Decode ARINC 429 Words from Receive block

Library

Simulink Real-Time Library for Arinc-429

Note

The input port of a Decode block is a signal of type double. Because the Decode block interprets the data on this port in a nonstandard way, you can send the data to this port from one of the following:

- Condor CEI-520A Receive, Condor (GE-IP) RCEI-530 Receive, and Condor (GE-IP) RCEI-830A Receive blocks — The ARINC Receive blocks output their data into standard double output. This is the block from which you will most likely send data to the ARINC Decode block.

The output port of a Decode block is in standard double format.

The input to this block should be a CEI-520A, RCEI-530, or CEI-830 Receive block. The Decode block input port width will automatically adapt to that of the source block.

Block Parameters

Label

Enter a three digit octal number. If the label of an input word does not match this label, the block completely ignores the word and does not apply the **Sync mask** and **Sync value** parameters.

Data type vector

Enter a vector consisting of values between 0 and 3. These values specify the data type. The length of this vector determines how many ARINC words the block will attempt to decode and output each sample time.

The elements of the vector determine how the input double value is converted to a corresponding double output value, as follows

Type	Interpretation
0	Raw — Convert the entire (unsigned) 32-bit input word to double.
1	BNR — For each word, convert bits 10–28 from signed binary format to a double output in the range [-Scale, Scale] using the Resolution (BCD) or Scale (BNR) vector scale factor specified for this value.
2	BCD — For each word, convert bits 10–28 from BCD format to double, using the sign data in the SSM.
3	Discretes — For each word, extract bits 10–28 and return them as a double.

The elements of the data type vector determine how the input ARINC value is converted to a corresponding double output. The following describes how this block performs the conversion. For the purposes of this description, n denotes the length of the data type vector.

- The output width is one of the following, depending on your time tag selection
 - $2n + 1$ — This is the output width if you select the **Provide time tags** check box. The width consists of a count element, followed by n data elements, followed by n time tag elements.
 - $n + 1$ — This is the output width if you do not select the **Provide time tags** check box. The width consists of a count element followed by n data elements.

The count element indicates how many valid messages the block has decoded during the current sample time. The count element has a nonzero value if at least one message on the data element is currently valid, and zero otherwise. If the count element has a value greater than one, the block asserts only the most recent valid message on the output port.

- The Decode block buffers its input internally. It updates its output port only during sample times when it has assembled at least one complete message of length n without detecting an error.

More than one complete message might be assembled during one sample time. The Decode block overwrites these messages such that only the most recent message is on the output port.

Resolution (BCD) or Scale (BNR) vector

Enter a vector or scalar value as the resolution vector. This value must be a vector of the same length as the **data type vector**. Otherwise, the scalar value is applied to the length of the **data type vector**. The interpretation of this value depends on the data type. The block works with the data types as follows.

Type	Effect
Raw	The block ignores the resolution value. However, you must still include an associated value in the resolution vector.
BNR	<p>The block uses this value as a scale factor. The block converts the binary value in bits 10–28 back to a double in the range [-1 , 1]. The block then multiplies that value by the scale value to recover the original value.</p> <p>A 19-bit signed ARINC binary can represent a range from -262,144 to 262,143. If the combination of input signal and resolution produces a value outside this range, the block clamps it to be within the range.</p>
BCD	<p>The resolution vector specifies, in the same units as the input signal, the value of the least significant digit of the BCD data field to be encoded and sent. For example, if the associated resolution is .01 and the input signal contains the value 3.1415, the output ARINC word will contain the number 314 in its data field, encoded in BCD. Use same resolution on the receive side to reconstruct 3.14. Resolution is typically a power of 10, but this is not a restriction.</p> <p>The range representable as an ARINC BCD value is -79,999 to 79,999. If the combination of input signal and resolution produces a value outside this range, the block limits it to within the range.</p>
Discretes	The block ignores the resolution value. However, you must still include an associated value in the resolution vector.

Sync mask

Enter a value, in hexadecimal, to specify which bits of the input words are the sync bits. (A sync bit lets you specify, using other parameters, when a message should begin.) The Decode block will examine these bits to look for the start of the next

message. A message might be a string of one or more words. For example, a sync mask value of 0x300 equals 1100000000 in binary. This value selects the SDI bits (bits 9 and 10) as the sync bits. This functionality works with the **Sync value** parameter.

If the sync mask is 0x0, sync logic is not used. The next word begins a new message.

Sync value(s)

This parameter specifies the sync logic for the block. Enter one hex value to specify **oneSync**, two hex values separated by a space for **twoSync** logic. For example, the sync value

0x100

selects **oneSync** logic. The sync value

0x100 0x200

selects **twoSync** logic. You can enter an 32-bit value.

The sync value takes into account the value of the sync mask, as follows:

- Assume the following:

Sync mask = 0x300

Sync value = 0x100

When looking for the beginning of a new message, the block ANDs each input word with the sync mask 0x300 and compares the result with 0x100 and 0x300. When it finds a match, the block stops this search and begins a new search, looking for the next message. The block decodes the next n words starting at this point.

- Assume the following:

Sync mask = 0x300

Sync value = 0x100 0x200

When looking for the beginning of a new message, the block ANDs each input word with 0x300 and compares the result to 0x100 and 0x300. When the block finds a match, and when the next input word, when ANDed with 0x300, equals 0x200 and 0x300, this second word begins a new message.

Once the block locates the beginning of a message, it uses the next n input words and the required label to assemble the next output message. The block does not use sync logic until it is time to begin the assembly of a new message.

Provide time tags

Select this check box to enable an output port of width $2n + 1$, with time tag data in the last n elements.

External Websites

- www.aviation-ia.com
- www.abaco.com

Condor 1553 Create BC Message List

Condor Create BC Message List block for bus controller

Library

Simulink Real-Time Library for MIL-STD-1553

Description

This block allocates space for a BC message list. It sets the messages in the list to no-op. This implies that the execution of a message on a given time step requires that a 1553 Encode BC Message block execute on that time step. The 1553 Create BC Message List block performs a clearing operation that allows you to control when a message is sent by placing 1553 Encode BC Message blocks in enabled subsystems.

Block Parameters

Number of message buffers

Enter the number of message buffers for the list. This block allocates an empty list for these buffers in Simulink Real-Time memory.

Sample time

Enter the base sample time or a multiple of the base sample time (-1 means sample time is inherited).

See Also

Condor 1553 Encode BC Message

More About

- “Bus Controller Operation” on page 43-7

External Websites

- www.milstd1553.com

- www.abaco.com

Condor 1553 Decode BC Message

Condor 1553 Decode BC Message block for bus controller

Library

Simulink Real-Time Library for MIL-STD-1553

Description

Each instance of this block extracts information out of one message in the receive list. This block has three outputs.

L — Specifies the input and output message list passed to other Decode BC Message blocks. If this is the only Decode BC Message block in your model, connect the signal to a terminator or ground.

S — The **S** output is a vector of six elements from the received message, bit packed with information:

```
control, command1, status1, command2, status2, overall status
```

These elements derive from the `API_BC_MBUF` structure, which is contained in the Simulink Real-Time file `matlab\toolbox\rtw\targets\xpc\target\build\xpcb\include\busapi.h`. See the GE Fanuc (formerly Condor Engineering) 1553 software user documentation for details on this structure.

Use the Decode BC Status block to extract individual status bits from this status. To get multiple status bits, use multiple Decode BC Status blocks and feed, in parallel, the same signal to the **S** ports.

D — The **D** output is a vector of 32 short integers with the data from that message. For a message sent to an RT (**R** direction), these values are the ones sent. For a message from an RT (**T** direction), this contains the values from the RT. You do not need to decode the received message from an **R** message.

Block Parameters

Message number

Enter the number of the message to decode.

Sample time

Enter the base sample time or a multiple of the base sample time (- 1 means sample time is inherited).

External Websites

- www.milstd1553.com
- www.abaco.com

Condor 1553 Decode BC Status

Condor 1553 Decode BC Status block for bus controller

Library

Simulink Real-Time Library for MIL-STD-1553

Description

This block extracts individual status bits from the status output of the Decode BC Message block.

Block Parameters

Status to read

From the list, choose a status to read. The Decode BC Status block extracts individual status bits from the status (S) output of the Decode BC Message block.

Sample time

Enter the base sample time or a multiple of the base sample time (- 1 means sample time is inherited).

External Websites

- www.milstd1553.com
- www.abaco.com

Condor 1553 Encode BC Message

Condor 1553 Encode BC Message block for bus controller

Library

Simulink Real-Time Library for MIL-STD-1553

Description

This block fills each message for the timestep during which the message should be sent.

The Create BC Message List block allocates an empty list of message buffers in Simulink Real-Time memory. Use the Encode BC Message block to fill these messages.

Block Parameters

Message number

Enter the number of the message to encode. Each BC message needs to use a unique message number. This is the place in the list to fill with this message.

Remote Terminal address 1 (Receive if RT-RT)

From the list, choose a Remote Terminal address 1.

Sub address 1 (Receive if RT-RT)

From the list, choose a Remote Terminal sub address 1. Setting this parameter to Send (0) mode command or Send (31) mode command disables the **Message word count** parameter.

Remote Terminal address 2 (Transmit if RT-RT)

From the list, choose a Remote Terminal address 2. This is not used if the **Direction** is R (BC->RT) or T (RT->BC).

Sub address 2 (Transmit if RT-RT)

From the list, choose a Remote Terminal sub address 2. This is not used if the **Direction** is R (BC->RT) or T (RT->BC).

Mode command

If the **Sub address 1 is 0 or 31**, from the list, choose a mode command.

Message word count

Specify the number of `uint16` words to send or receive.

Direction

From the list, choose the encode direction. Choose from

- R (BC->RT)
- T (RT->BC)
- RT->RT

Inter message gap to next message (usec)

Specify the minimum amount of time, in microseconds, between messages.

Output bus

From the list, choose output bus **A** or **B** that this message will be sent on.

Sample time

Enter the base sample time or a multiple of the base sample time (- 1 means sample time is inherited).

See Also

Condor 1553 Create BC Message List | Condor 1553 Decode BC Message

External Websites

- www.milstd1553.com
- www.abaco.com

Condor 1553 Select BM Message

Condor Select 1553 BM Message block for bus monitor

Library

Simulink Real-Time Library for MIL-STD-1553

Description

This block picks a message with specified properties out of a Bus Monitor list from the PCI-1553 Bus Monitor block.

Block Input and Outputs

This block has the following inputs and outputs:

L — The passed through message list

T — Time in microseconds at which this message was received

S — Status (seven component vector with contents)

- 1 message number
- 2 cmd1
- 3 resp1
- 4 status 1
- 5 cmd 2
- 6 resp 2
- 7 status 2

Elements cmd1 and cmd2 contain address information in bit fields in the 16-bit integer.

cmdN=<RRRRR>T<SSSSS><CCCCC>

Where RRRRR is the 5-bit field with the remote terminal address. T is 1 if a transmit message, 0 if receive. S is the sub address. C is the count.

Elements 5, 6, and 7 are only nonzero for the RT->RT messages.

D — 32 uint16 vector data. cmd 1 has the length of real data in the low order 5 bits.

The block clears the status and data words to 0 if a matching message is not found in the list.

Block Parameters

Message selection mode

From the list, choose a message selection (filtering) mode

- message number — By message number
- BC->RT or RT->BC — By Remote Terminal and sub address
- RT->RT — By both Remote Terminal and sub addresses

Message number

Specify an index into a Bus Monitor list. Use this parameter if you set **Message selection mode** to message number.

Remote Terminal 1

Specify the Remote Terminal from which to select the message. Use this parameter if you set **Message selection mode** to one of the following:

- BC->RT or RT->BC
- RT->RT (receive side)

Sub address 1

Specify the sub address from which to select the message. Use this parameter if you set **Message selection mode** to one of the following:

- BC->RT or RT->BC
- RT->RT (receive side)

Remote Terminal 2

Specify the Remote Terminal from which to select the message. Use this parameter if you set **Message selection mode** to RT->RT (send side).

Sub address 2

Specify the sub address from which to select the message. Use this parameter if you set **Message selection mode** to RT->RT (send side).

Direction

From the list, choose the encode direction. Use this parameter if you set **Message selection mode** to BC->RT or RT->BC. Choose from

- R (BC->RT) — Receive, from Bus Controller to Remote Terminal
- T (RT->BC) — Transmit, from Remote Terminal to Bus Controller

Sample time

Enter the base sample time or a multiple of the base sample time (- 1 means sample time is inherited).

See Also

Condor PCI-1553 Bus Monitor

External Websites

- www.milstd1553.com
- www.abaco.com

Condor PCI-1553

Support for MIL-STD-1553 PCI boards

Board

Condor PCI-1553

General Description

The MIL-STD-1553 driver library allows real-time applications to connect to a MIL-STD-1553 bus network to send and receive messages of up to 32 16-bit words. You must be familiar with the MIL-STD-1553 standard.

The Simulink Real-Time block library supports the MIL-STD-1553 protocol with PCI-1553 boards. These boards connect a target computer to a MIL-STD-1553 data bus via the PCI bus.

The PCI-1553 board is available with 1 or 2 channels as either a single function or a multifunction configuration. The multifunction version supports simultaneous use of the Bus Controller, Bus Monitor, and Remote Terminal functions. The single function version emits an error if more than one function is initialized. PCI-1553 blocks support up to two channels for this board.

To support these boards, the block library provides the following driver blocks:

- Condor PCI-1553 Bus Controller Send
- Condor PCI-1553 Bus Monitor
- Condor PCI-1553 Initialize
- Condor PCI-1553 RT Initialize
- Condor PCI-1553 RT Receive
- Condor PCI-1553 RT Send

To format the Bus Controller messages, use the following utility blocks:

- Condor 1553 Create BC Message List

- Condor 1553 Decode BC Message
- Condor 1553 Decode BC Status
- Condor 1553 Encode BC Message
- Condor 1553 Select BM Message

Board Characteristics

Board name	PCI-1553
Manufacturer	GE Fanuc (formerly Condor Engineering)
Bus type	PCI
Multiple board support	Yes

External Websites

- www.milstd1553.com
- www.abaco.com

Condor PCI-1553 Bus Controller Send

Condor PCI-1553 BC Send block for bus controller

Library

Simulink Real-Time Library for MIL-STD-1553

Description

This block sends a list of messages to the specified channel on the board. Before you construct the list of messages:

- 1 Allocate space for the list with the Condor 1553 Create BC Message List block.
- 2 Fill in information about each message with Condor 1553 Encode BC Message blocks.

Each instance of an Encode BC Message block fills in information for a single message on the list. Daisy chain the Encode BC Message block L signals so that the Encode BC blocks execute before the Bus Controller Send block.

The Bus Controller Send block allocates a list for the reception of messages. This block can:

- Read the set of messages and statuses from the last time a message was sent before sending the new list.
- Send the new list and wait for a response.

In other words, for time step N, the output of the Send block is either the response to time step N-1 or the response to time step N, chosen from the **Response mode** parameter.

Block Parameters

Channel

From the list of available channels on the board, choose 1 or 2. This channel is initialized for this command stream.

Response mode

Choose from:

- **Read response to previous message then send new message** — Before sending new messages, read the command buffers from the board.
- **Send new message then wait and read response** — Transmit new message, and then wait for response before continuing.

Use the **Maximum wait time (microseconds)** parameter to set the amount of time the block must wait for a response.

Maximum wait time (microseconds)

Enter the maximum time that this block waits for the message stream to be sent by the board. If the **Response mode** parameter is set to **Send new message then wait and read response**, use this parameter.

A reasonable maximum wait time is 1000 microseconds (1 millisecond). This value must not exceed the sample time. Exceeding the sample time triggers an execution overload.

Sample time

Enter the base sample time or a multiple of the base sample time (- 1 means sample time is inherited).

PCI slot (-1:autosearch)

If only one board of this type is in the target computer, enter - 1 to locate the board.

If two or more boards of this type are in the target computer, enter the bus number and the PCI slot number of the board associated with this driver block. Use the format **[BusNumber, SlotNumber]**.

To determine the bus number and the PCI slot number, type:

```
tg = slrt;  
getPCIInfo(tg, 'installed')
```

External Websites

- www.milstd1553.com
- www.abaco.com

Condor PCI-1553 Bus Monitor

Condor PCI-1553 Bus Monitor (BM) block

Library

Simulink Real-Time Library for MIL-STD-1553

Block Parameters

Channel

From the list of available channels on the board, choose 1 or 2. This channel is initialized for this command stream.

Maximum number of messages to receive

Enter the maximum number of messages this block must read from the board.

Sample time

Enter the base sample time or a multiple of the base sample time (- 1 means sample time is inherited).

PCI slot (-1:autosearch)

If only one board of this type is in the target computer, enter - 1 to locate the board.

If two or more boards of this type are in the target computer, enter the bus number and the PCI slot number of the board associated with this driver block. Use the format **[BusNumber, SlotNumber]**.

To determine the bus number and the PCI slot number, type:

```
tg = slrt;  
getPCIInfo(tg, 'installed')
```

External Websites

- www.milstd1553.com
- www.abaco.com

Condor PCI-1553 Initialize

Condor PCI-1553 Initialize block

Library

Simulink Real-Time Library for MIL-STD-1553

Block Parameters

Channel

From the list of available channels on the board, choose 1 or 2. This channel is initialized for this command stream.

Coupling mode

From the list, select from **Direct Coupling** and **Transformer Coupling**. This selection defines the mode for coupling a terminal device to the bus.

Initialize for Bus Controller operation

Select this check box to perform Bus Controller initialization for this channel. Selecting this check box enables the parameters **Number of Bus Controller buffers to allocate**, **Enable retries**, **No response timeout (microseconds)**, and **Late response timeout (microseconds)**.

Number of Bus Controller buffers to allocate

Enter the number of buffers to allocate in onboard memory on the board. This number must be greater than or equal to the longest string of command buffers that the board is given to process.

Enable retries

Select this check box to enable automatic retries when a message times out or has an error.

No response timeout (microseconds)

Enter the number of microseconds the board is to wait for a response from the Remote Terminal. If the response from the Remote Terminal takes longer than this timeout value, the board sets the NORESPONSE error condition in the status returned from the command.

Late response timeout (microseconds)

Enter the number of microseconds the board is to wait for a response from the Remote Terminal. If the response from the Remote Terminal takes longer than this timeout value, the board sets the LATERESPONSE error condition in the status returned from the command.

Initialize for Bus Monitor operation

Select this check box to initialize this channel for Bus Monitor operation. Selecting this check box enables the parameters **Monitor bus A**, **Monitor bus B**, and **Number of monitor buffers to allocate**.

Monitor bus A

Select this check box to monitor bus A. You can monitor either bus A, bus B, or both.

Monitor bus B

Select this check box to monitor bus B. You can monitor either bus B, bus A, or both.

Number of monitor buffers to allocate

Enter a number at least as large as the number of messages that you expect to see between calls to the Bus Monitor block. If more messages arrive than there are buffers, some messages are lost and not monitored.

Initialize for Remote Terminal operation

Select this check box to prepare the board to operate as a Remote Terminal. If you select this check box, add the RT Initialize block to the model to initialize the Remote Terminal. Connect the RT Initialize block for the Remote Terminal to the S output of this block.

Selecting this check box enables the parameter **RT address 31 is Broadcast**.

RT address 31 is Broadcast

Select this check box to enable the board to see messages to Remote Terminal 31 as broadcast messages.

Sample time

Enter the base sample time or a multiple of the base sample time (- 1 means sample time is inherited).

PCI slot (-1:autosearch)

If only one board of this type is in the target computer, enter - 1 to locate the board.

If two or more boards of this type are in the target computer, enter the bus number and the PCI slot number of the board associated with this driver block. Use the format **[BusNumber,SlotNumber]**.

To determine the bus number and the PCI slot number, type:

```
tg = slrt;  
getPCIInfo(tg, 'installed')
```

External Websites

- www.milstd1553.com
- www.abaco.com

Condor PCI-1553 RT Initialize

Condor PCI-1553 RT Initialize block

Library

Simulink Real-Time Library for MIL-STD-1553

Description

Add an RT Initialize block for each Remote Terminal address for which you want this board to accept commands. Because each of these blocks must execute after the global board initialization, connect the **S** input to either the:

- Main Condor PCI-1553 Initialize block for this board
- Another Condor PCI-1553 RT Initialize block that is connected to the main Condor PCI-1553 Initialize block

This connection carries the channel number and PCI slot information.

Block Parameters

Remote Terminal

From the list, choose a Remote Terminal from 0 to 31. The remote terminal number configured in RT Send and RT Receive must match that specified by the corresponding RT Initialize block.

Connect to bus A

Select this check box to have this Remote Terminal listen on bus A. If a message can come in on either bus, choose both A and B.

Connect to bus B

Select this check box to have this Remote Terminal listen on bus B. If a message can come in on either bus, choose both A and B.

Initial status

Enter the value to which the board should initialize the status before it executes commands. The board maintains a status word that it sends to the Bus Controller after it executes a command.

Initial BIT word

Enter the initial value of the Built In Test (BIT) word. The Remote Terminal sends this word in response to the Transmit BIT Word mode code.

Inhibit terminal flag

Select this check box to inhibit the Remote Terminal flag. This value is the initial value of the Inhibit Terminal Flag bit. This value can be changed from the Bus Controller with the Inhibit Terminal and Override Inhibit Terminal mode codes. The terminal bit is one of the bits in the status word that is maintained by the I/O module.

Transmit sub addresses

Enter a vector of sub addresses to which this Remote Terminal must respond. These sub addresses are the sub addresses that can transmit data when requested. Each element of the vector must correspond to the corresponding element of the **Legal transmit message lengths** vector. To enable the sub address for the Remote Terminal, include the sub address in the vector.

A Remote Terminal accepts a message only if it has been directed to accept messages of the same length. During initialization, the board must receive a list of valid message lengths for each Remote Terminal number.

Legal transmit message lengths

Enter a vector of transmit message lengths. This vector is a vector of bit masks. Each mask bit corresponds to a single message length. Construct the transmit message length vector as follows:

- Each element of the vector corresponds to the corresponding element of the **Transmit sub addresses** vector.
- Each element of the vector corresponds to the corresponding element of the **Legal receive message lengths**. Failure to do so prevents the sub address on this Remote Terminal from responding.

A message can have a length of from 1 to 32 words, selected by setting one or more bits in a 32-bit mask.

Bit Position	Mask Value (hex)	Word Length (words)
0	0x00000001	32

Bit Position	Mask Value (hex)	Word Length (words)
1	0x00000002	1
2	0x00000004	2
...		
30	0x40000000	30
31	0x80000000	31

- Use the `hex2dec` function to specify the bit mask in hexadecimal.
- The message length is expressed by bit position in the mask, not by mask value. The value `0xffffffff` enables all message lengths from 1 to 32.
- The board does not accept a message with a disallowed length. The board sends an error to the Bus Controller by returning a status with the Message Error bit set.

Receive sub addresses

Enter a vector of the sub addresses that can accept a receive message. Each element of the vector must correspond to the corresponding element of the **Legal receive message lengths** vector. To enable the sub address for the Remote Terminal, include the sub address in the vector.

A Remote Terminal accepts a message only if it has been directed to accept messages of the same length. During initialization, the board must receive a list of valid message lengths for each Remote Terminal number.

Legal receive message lengths

Enter a vector of receive message lengths. This vector is a vector of bit masks. Each bit corresponds to a single message length. Construct the receive message lengths vector as follows:

- Each element of the vector corresponds to the corresponding element of the **Transmit sub addresses** vector.
- Each element of the vector corresponds to the corresponding element of the **Receive sub addresses** vector.
- Each element of the vector corresponds to the corresponding element of the **Legal transmit message lengths**. Failure to do so prevents the sub address on this Remote Terminal from responding.

A message can have a length of from 1 to 32 words, selected by setting one or more bits in a 32-bit mask.

Bit Position	Mask Value (hex)	Word Length (words)
0	0x00000001	32
1	0x00000002	1
2	0x00000004	2
...		
30	0x40000000	30
31	0x80000000	31

- Use the `hex2dec` function to specify the bit mask in hexadecimal.
- The message length is expressed by bit position in the mask, not by mask value. The value `0xffffffff` enables all message lengths from 1 to 32.
- The board does not accept a message with a disallowed length. The board sends an error to the Bus Controller by returning a status with the Message Error bit set.

Sample time

Enter the base sample time or a multiple of the base sample time (- 1 means sample time is inherited).

External Websites

- www.milstd1553.com
- www.abaco.com

Condor PCI-1553 RT Receive

Condor PCI-1553 RT Receive block for remote terminal

Library

Simulink Real-Time Library for MIL-STD-1553

Note

Your model might have multiple Remote Terminal Receive blocks. To help you locate a particular block, the Remote Terminal Receive block displays the channel number and address parameters. The address display has the format:

```
remote terminal-R-sub address-number of words
```

Remote terminal — Is the **Remote Terminal** parameter

R — Indicates receive command

Subaddress — Is the **Sub address** parameter

Number of words — Is the **Number of words to receive** parameter

A receive command for RT 1, sub address 3 to receive 2 words has the layout 1-R-3-2.

Block Parameters

Channel

From the list of available channels on the board, choose 1 or 2. This channel is initialized for this command stream.

Remote Terminal

From the list, choose a Remote Terminal from 0 to 31. The remote terminal number configured in RT Send and RT Receive must match that specified by the corresponding RT Initialize block.

Sub address

From the list, choose a sub address from 0 to 31. Select the sub address for this message.

Number of words to receive

Enter the number of 16-bit integers to receive as the data part of this message. This number must be between 1 and 32. The output data vector has the same vector width.

If this Remote Terminal or sub address can be sent messages with different lengths, specify the longest message length for this parameter. You must determine how much length is significant from content.

Enable timestamp output

Select this check box to cause output T to appear.

Output T returns the time, in microseconds, at which the most recent message was received. The time is measured from the beginning of execution.

Sample time

Enter the base sample time or a multiple of the base sample time (- 1 means sample time is inherited).

PCI slot (-1:autosearch)

If only one board of this type is in the target computer, enter - 1 to locate the board.

If two or more boards of this type are in the target computer, enter the bus number and the PCI slot number of the board associated with this driver block. Use the format [**BusNumber,SlotNumber**].

To determine the bus number and the PCI slot number, type:

```
tg = slrt;  
getPCIInfo(tg, 'installed')
```

External Websites

- www.milstd1553.com
- www.abaco.com

Condor PCI-1553 RT Send

Condor PCI-1553 RT Send block for remote terminal

Library

Simulink Real-Time Library for MIL-STD-1553

Description

A Remote Terminal sends data only if it receives a transmit command from the Bus Controller. This block prepares the board for the next transmit command on this channel, Remote Terminal number, and sub address as specified by the Initialize and RT Initialize blocks.

The data vector signal input to this block is copied to the board message buffer that corresponds to the specified address. The input data vector must have the same length as specified in the **Number of words to send** parameter. The input vector can be either 16- or 32-bit signed or unsigned data. The block sends only the bottom 16 bits of each element.

Your model might have multiple Remote Terminal Send blocks. To help you locate a particular block, the Remote Terminal Send block displays the channel number and address parameters. The address display has the format:

```
remote terminal-T-sub address-number of words
```

Remote terminal — Derives from the **Remote Terminal** parameter

T — Indicates transmit (or send) command

Subaddress — Derives from the **Sub address** parameter

Number of words — Derives from the **Number of words to receive** parameter

A transmit command for RT 1, sub address 3 to send 2 words has the layout 1 - T - 3 - 2.

Block Parameters

Channel

From the list of available channels on the board, choose 1 or 2. This channel is initialized for this command stream.

Remote Terminal

From the list, choose a Remote Terminal from 0 to 31. The remote terminal number configured in RT Send and RT Receive must match that specified by the corresponding RT Initialize block.

Sub address

From the list, choose a sub address from 0 to 31. Select the sub address for this message.

Number of words to send

Enter the number of 16-bit integers to send as the data part of this message. This number must be between 1 and 32. The input data vector must have the same vector width.

Sample time

Enter the base sample time or a multiple of the base sample time (- 1 means sample time is inherited).

PCI slot (-1:autosearch)

If only one board of this type is in the target computer, enter - 1 to locate the board.

If two or more boards of this type are in the target computer, enter the bus number and the PCI slot number of the board associated with this driver block. Use the format **[BusNumber, SlotNumber]**.

To determine the bus number and the PCI slot number, type:

```
tg = slrt;  
getPCIInfo(tg, 'installed')
```

External Websites

- www.milstd1553.com
- www.abaco.com

Condor Q104-1553

Support for MIL-STD-1553 PC104 boards

Board

Condor Q104-1553

General Description

The MIL-STD-1553 driver library allows real-time applications to connect to a MIL-STD-1553 bus network to send and receive messages of up to 32 16-bit words. You must be familiar with the MIL-STD-1553 standard.

The Simulink Real-Time block library supports the MIL-STD-1553 protocol with Q104-1553 boards. These boards connect a target computer to a MIL-STD-1553 data bus via the PC104 bus.

The Q104-1553 board is available with 1, 2, 3, or 4 channels as either a single function or multifunction configuration. The multifunction version supports simultaneous use of the Bus Controller, Bus Monitor, and Remote Terminal functions. The single function version emits an error if more than one function is initialized.

To support these boards, the block library provides the following driver blocks:

- Condor Q104-1553 Bus Controller Send
- Condor Q104-1553 Bus Monitor
- Condor Q104-1553 Initialize
- Condor Q104-1553 RT Initialize
- Condor Q104-1553 RT Receive
- Condor Q104-1553 RT Send

To format the Bus Controller messages, use the following utility blocks:

- Condor 1553 Create BC Message List
- Condor 1553 Decode BC Message

- Condor 1553 Decode BC Status
- Condor 1553 Encode BC Message
- Condor 1553 Select BM Message

Board Characteristics

Board name	Q104-1553
Manufacturer	GE Fanuc (formerly Condor Engineering)
Bus type	PC104
Multiple board support	Yes

External Websites

- www.milstd1553.com
- www.abaco.com

Condor Q104-1553 Bus Controller Send

Condor Q104-1553 BC Send block for bus controller

Library

Simulink Real-Time Library for MIL-STD-1553

Description

This block sends a list of messages to the specified channel on the board. Before you construct the list of messages:

- 1 Allocate space for the list with the Condor 1553 Create BC Message List block.
- 2 Fill in information about each message with Condor 1553 Encode BC Message blocks.

Each instance of an Encode BC Message block fills in information for a single message on the list. Daisy chain the Encode BC Message block L signals so the Encode BC blocks execute before the Bus Controller Send block.

The Bus Controller Send block allocates a list for the reception of messages. This block can:

- Read the set of messages and statuses from the last time a message was sent before sending the new list.
- Send the new list and wait for a response.

In other words, for time step N, the output of the Send block is either the response to time step N-1 or the response to time step N, chosen from the **Response mode** parameter.

Block Parameters

Channel

From the list of available channels on the board, choose 1, 2, 3, or 4. This channel is initialized for this command stream.

Response mode

Choose from:

- **Read response to previous message then send new message** — Before sending new messages, read the command buffers from the board.
- **Send new message then wait and read response** — Transmit new message, and then wait for response before continuing.

Use the **Maximum wait time (microseconds)** parameter to set the amount of time the block must wait for a response.

Maximum wait time (microseconds)

Enter the maximum time that this block waits for the message stream to be sent by the board. If the **Response mode** parameter is set to **Send new message then wait and read response**, use this parameter.

A reasonable maximum wait time is 1000 microseconds (1 millisecond). This value must not exceed the sample time. Exceeding the sample time triggers an execution overload.

Sample time

Enter the base sample time or a multiple of the base sample time (- 1 means sample time is inherited).

Base address

Enter the base address of the board. This entry must correspond to the DIP switch setting on the board. For example, if the DIP switch setting is 300 (hexadecimal), enter 0x300.

External Websites

- www.milstd1553.com
- www.abaco.com

Condor Q104-1553 Bus Monitor

Condor Q104-1553 Bus Monitor (BM) block

Library

Simulink Real-Time Library for MIL-STD-1553

Block Parameters

Channel

From the list of available channels on the board, choose 1, 2, 3, or 4. This channel is initialized for this command stream.

Maximum number of messages to receive

Enter the maximum number of messages this block must read from the board.

Sample time

Enter the base sample time or a multiple of the base sample time (- 1 means sample time is inherited).

Base address

Enter the base address of the board. This entry must correspond to the DIP switch setting on the board. For example, if the DIP switch setting is 300 (hexadecimal), enter 0x300.

External Websites

- www.milstd1553.com
- www.abaco.com

Condor Q104-1553 Initialize

Condor Q104-1553 Initialize block

Library

Simulink Real-Time Library for MIL-STD-1553

Block Parameters

Channel

From the list of available channels on the board, choose 1, 2, 3, or 4. This channel is initialized for this command stream.

Initialize for Bus Controller operation

Select this check box to perform Bus Controller initialization for this channel.

Selecting this check box enables the parameters **Number of Bus Controller buffers to allocate**, **Enable retries**, **No response timeout (microseconds)**, and **Late response timeout (microseconds)**.

Number of Bus Controller buffers to allocate

Enter the number of buffers to allocate in onboard memory on the board. This number must be greater than or equal to the longest string of command buffers that the board is given to process.

Enable retries

Select this check box to enable automatic retries when a message times out or has an error.

No response timeout (microseconds)

Enter the number of microseconds the board is to wait for a response from the Remote Terminal. If the response from the Remote Terminal takes longer than this timeout value, the board sets the NORESPONSE error condition in the status returned from the command.

Late response timeout (microseconds)

Enter the number of microseconds the board is to wait for a response from the Remote Terminal. If the response from the Remote Terminal takes longer than

this timeout value, the board sets the LATERESPONSE error condition in the status returned from the command.

Initialize for Bus Monitor operation

Select this check box to initialize this channel for Bus Monitor operation. Selecting this check box enables the parameters **Monitor bus A**, **Monitor bus B**, and **Number of monitor buffers to allocate**.

Monitor bus A

Select this check box to monitor bus A. You can monitor either bus A, bus B, or both.

Monitor bus B

Select this check box to monitor bus B. You can monitor either bus B, bus A, or both.

Number of monitor buffers to allocate

Enter a number at least as large as the number of messages that you expect to see between calls to the Bus Monitor block. If more messages arrive than there are buffers, some messages are lost and not monitored.

Initialize for Remote Terminal operation

Select this check box to prepare the board to operate as a Remote Terminal. If you select this check box, add the RT Initialize block to the model to initialize the Remote Terminal. Connect the RT Initialize block for the Remote Terminal to the S output of this block.

Selecting this check box enables the parameter **RT address 31 is Broadcast**.

RT address 31 is Broadcast

Select this check box to enable the board to see messages to Remote Terminal 31 as broadcast messages.

Sample time

Enter the base sample time or a multiple of the base sample time (- 1 means sample time is inherited).

Base address

Enter the base address of the board. This entry must correspond to the DIP switch setting on the board. For example, if the DIP switch setting is 300 (hexadecimal), enter 0x300.

External Websites

- www.milstd1553.com
- www.abaco.com

Condor Q104-1553 RT Initialize

Condor Q104-1553 RT Initialize block

Library

Simulink Real-Time Library for MIL-STD-1553

Description

Add an RT Initialize block for each Remote Terminal address for which you want this board to accept commands. Because each of these blocks must execute after the global board initialization, connect the **S** input to either the:

- Main Condor Q104-1553 Initialize block for this board
- Another Condor Q104-1553 RT Initialize block that is connected to the main Condor Q104-1553 Initialize block

This connection carries the channel number and PC104 base address.

Block Parameters

Remote Terminal

From the list, choose a Remote Terminal from 0 to 31. The remote terminal number configured in RT Send and RT Receive must match that specified by the corresponding RT Initialize block.

Connect to bus A

Select this check box to have this Remote Terminal listen on bus A. If a message can come in on either bus, choose both A and B.

Connect to bus B

Select this check box to have this Remote Terminal listen on bus B. If a message can come in on either bus, choose both A and B.

Initial status

Enter the value to which the board should initialize the status before it executes commands. The board maintains a status word that it sends to the Bus Controller after it executes a command.

Initial BIT word

Enter the initial value of the Built In Test (BIT) word. The Remote Terminal sends this word in response to the Transmit BIT Word mode code.

Inhibit terminal flag

Select this check box to inhibit the Remote Terminal flag. This value is the initial value of the Inhibit Terminal Flag bit. This value can be changed from the Bus Controller with the Inhibit Terminal and Override Inhibit Terminal mode codes. The terminal bit is one of the bits in the status word that is maintained by the I/O module.

Transmit sub addresses

Enter a vector of sub addresses to which this Remote Terminal must respond. These sub addresses are the sub addresses that can transmit data when requested. Each element of the vector must correspond to the corresponding element of the **Legal transmit message lengths** vector. To enable the sub address for the Remote Terminal, include the sub address in the vector.

A Remote Terminal accepts a message only if it has been directed to accept messages of the same length. During initialization, the board must receive a list of valid message lengths for each Remote Terminal number.

Legal transmit message lengths

Enter a vector of transmit message lengths. This vector is a vector of bit masks. Each mask bit corresponds to a single message length. Construct the transmit message length vector as follows:

- Each element of the vector corresponds to the corresponding element of the **Transmit sub addresses** vector.
- Each element of the vector corresponds to the corresponding element of the **Legal receive message lengths**. Failure to do so prevents the sub address on this Remote Terminal from responding.

A message can have a length of from 1 to 32 words, selected by setting one or more bits in a 32-bit mask.

Bit Position	Mask Value (hex)	Word Length (words)
0	0x00000001	32

Bit Position	Mask Value (hex)	Word Length (words)
1	0x00000002	1
2	0x00000004	2
...		
30	0x40000000	30
31	0x80000000	31

- Use the `hex2dec` function to specify the bit mask in hexadecimal.
- The message length is expressed by bit position in the mask, not by mask value. The value `0xffffffff` enables all message lengths from 1 to 32.
- The board does not accept a message with a disallowed length. The board sends an error to the Bus Controller by returning a status with the Message Error bit set.

Receive sub addresses

Enter a vector of the sub addresses that can accept a receive message. Each element of the vector must correspond to the corresponding element of the **Legal receive message lengths** vector. To enable the sub address for the Remote Terminal, include the sub address in the vector.

A Remote Terminal accepts a message only if it has been directed to accept messages of the same length. During initialization, the board must receive a list of valid message lengths for each Remote Terminal number.

Legal receive message lengths

Enter a vector of receive message lengths. This vector is a vector of bit masks. Each bit corresponds to a single message length. Construct the receive message lengths vector as follows:

- Each element of the vector corresponds to the corresponding element of the **Transmit sub addresses** vector.
- Each element of the vector corresponds to the corresponding element of the **Receive sub addresses** vector.
- Each element of the vector corresponds to the corresponding element of the **Legal transmit message lengths**. Failure to do so prevents the sub address on this Remote Terminal from responding.

A message can have a length of from 1 to 32 words, selected by setting one or more bits in a 32-bit mask.

Bit Position	Mask Value (hex)	Word Length (words)
0	0x00000001	32
1	0x00000002	1
2	0x00000004	2
...		
30	0x40000000	30
31	0x80000000	31

- Use the `hex2dec` function to specify the bit mask in hexadecimal.
- The message length is expressed by bit position in the mask, not by mask value. The value `0xffffffff` enables all message lengths from 1 to 32.
- The board does not accept a message with a disallowed length. The board sends an error to the Bus Controller by returning a status with the Message Error bit set.

Sample time

Enter the base sample time or a multiple of the base sample time (- 1 means sample time is inherited).

External Websites

- www.milstd1553.com
- www.abaco.com

Condor Q104-1553 RT Receive

Condor Q104-1553 RT Receive block for remote terminal

Library

Simulink Real-Time Library for MIL-STD-1553

Note

Your model might have multiple Remote Terminal Receive blocks. To help you locate a particular block, the Remote Terminal Receive block displays the number and address parameters in the following format:

```
remote terminal-R-sub address-number of words
```

Remote terminal — Is the **Remote Terminal** parameter

R — Indicates receive command

Subaddress — Is the **Sub address** parameter

Number of words — Is the **Number of words to receive** parameter

A receive command for RT 1, sub address 3 to receive 2 words has the layout 1-R-3-2.

Block Parameters

Channel

From the list of available channels on the board, choose 1, 2, 3, or 4. This channel is initialized for this command stream.

Remote Terminal

From the list, choose a Remote Terminal from 0 to 31. The remote terminal number configured in RT Send and RT Receive must match that specified by the corresponding RT Initialize block.

Sub address

From the list, choose a sub address from 0 to 31. Select the sub address for this message.

Number of words to receive

Enter the number of 16-bit integers to receive as the data part of this message. This number must be between 1 and 32. The output data vector has the same vector width.

If this Remote Terminal or sub address can be sent messages with different lengths, specify the longest message length for this parameter. You must determine how much length is significant from content.

Enable timestamp output

Select this check box to cause output T to appear.

Output T returns the time, in microseconds, at which the most recent message was received. The time is measured from the beginning of execution.

Sample time

Enter the base sample time or a multiple of the base sample time (- 1 means sample time is inherited).

Base address

Enter the base address of the board. This entry must correspond to the DIP switch setting on the board. For example, if the DIP switch setting is 300 (hexadecimal), enter 0x300.

External Websites

- www.milstd1553.com
- www.abaco.com

Condor Q104-1553 RT Send

Condor Q104-1553 RT Send block for remote terminal

Library

Simulink Real-Time Library for MIL-STD-1553

Description

A Remote Terminal sends data only if it receives a transmit command from the Bus Controller. This block prepares the board for the next transmit command on this channel, Remote Terminal number, and sub address as specified by the Initialize and RT Initialize blocks.

The data vector signal input to this block is copied to the board message buffer that corresponds to the specified address. The input data vector must have the same length as specified in the **Number of words to send** parameter. The input vector can be either 16- or 32-bit signed or unsigned data. The block sends only the bottom 16 bits of each element.

Your model might have multiple Remote Terminal Send blocks. To help you locate a particular block, the Remote Terminal Send block displays the number and address parameters in the following format:

```
remote terminal-T-sub address-number of words
```

Remote terminal — Is the **Remote Terminal** parameter

T — Indicates transmit (or send) command

Subaddress — Is the **Sub address** parameter

Number of words — Is the **Number of words to receive** parameter

A transmit command for RT 1, sub address 3 to send 2 words has the layout 1-T-3-2.

Block Parameters

Channel

From the list of available channels on the board, choose 1, 2, 3, or 4. This channel is initialized for this command stream.

Remote Terminal

From the list, choose a Remote Terminal from 0 to 31. The remote terminal number configured in RT Send and RT Receive must match that specified by the corresponding RT Initialize block.

Sub address

From the list, choose a sub address from 0 to 31. Select the sub address for this message.

Number of words to send

Enter the number of 16-bit integers to send as the data part of this message. This number must be between 1 and 32. The input data vector must have the same vector width.

Sample time

Enter the base sample time or a multiple of the base sample time (- 1 means sample time is inherited).

Base address

Enter the base address of the board. This entry must correspond to the DIP switch setting on the board. For example, if the DIP switch setting is 300 (hexadecimal), enter 0x300.

External Websites

- www.milstd1553.com
- www.abaco.com

Condor QPCI-1553

Support for MIL-STD-1553 QPCI boards

Board

Condor QPCI-1553

General Description

The MIL-STD-1553 driver library allows real-time applications to connect to a MIL-STD-1553 bus network to send and receive messages of up to 32 16-bit words. You must be familiar with the MIL-STD-1553 standard.

The Simulink Real-Time block library supports the MIL-STD-1553 protocol with QPCI-1553 boards. These boards connect a target computer to a MIL-STD-1553 data bus via the high-density PCI (QPCI) bus.

The QPCI-1553 board is available with 1, 2, 3, or 4 channels as either a single function or multifunction configuration. The multifunction version supports simultaneous use of the Bus Controller, Bus Monitor, and Remote Terminal functions. The single function version emits an error if more than one function is initialized. This board also supports a loopback mode for testing. QPCI-1553 blocks support up to four channels for this board.

To support these boards, the block library provides the following driver blocks:

- Condor QPCI-1553 Bus Controller Send
- Condor QPCI-1553 Bus Monitor
- Condor QPCI-1553 Initialize
- Condor QPCI-1553 RT Initialize
- Condor QPCI-1553 RT Receive
- Condor QPCI-1553 RT Send

To format the Bus Controller messages, use the following utility blocks:

- Condor 1553 Create BC Message List

- Condor 1553 Decode BC Message
- Condor 1553 Decode BC Status
- Condor 1553 Encode BC Message
- Condor 1553 Select BM Message

Board Characteristics

Board name	QPCI-1553
Manufacturer	GE Fanuc (formerly Condor Engineering)
Bus type	QPCI
Multiple board support	Yes

External Websites

- www.milstd1553.com
- www.abaco.com

Condor QPCI-1553 Bus Controller Send

Condor QPCI-1553 BC Send block for bus controller

Library

Simulink Real-Time Library for MIL-STD-1553

Description

This block sends a list of messages to the specified channel on the board. Before you construct the list of messages:

- 1 Allocate space for the list with the Condor 1553 Create BC Message List block.
- 2 Fill in information about each message with Condor 1553 Encode BC Message blocks.

Each instance of an Encode BC Message block fills in information for a single message on the list. Daisy chain the Encode BC Message block L signals so the Encode BC blocks execute before the Bus Controller Send block.

The Bus Controller Send block allocates a list for the reception of messages. This block can:

- Read the set of messages and statuses from the last time a message was sent before sending the new list.
- Send the new list and wait for a response.

In other words, for time step N, the output of the Send block is either the response to time step N-1 or the response to time step N, chosen from the **Response mode** parameter.

Block Parameters

Channel

From the list of available channels on the board, choose 1, 2, 3, or 4. This channel is initialized for this command stream.

Response mode

Choose from:

- **Read response to previous message then send new message** — Before sending new messages, read the command buffers from the board.
- **Send new message then wait and read response** — Transmit new message, and then wait for response before continuing.

Use the **Maximum wait time (microseconds)** parameter to set the amount of time the block must wait for a response.

Maximum wait time (microseconds)

Enter the maximum time that this block waits for the message stream to be sent by the board. If the **Response mode** parameter is set to **Send new message then wait and read response**, use this parameter.

A reasonable maximum wait time is 1000 microseconds (1 millisecond). This value must not exceed the sample time. Exceeding the sample time triggers an execution overload.

Sample time

Enter the base sample time or a multiple of the base sample time (- 1 means sample time is inherited).

PCI slot (-1:autosearch)

If only one board of this type is in the target computer, enter - 1 to locate the board.

If two or more boards of this type are in the target computer, enter the bus number and the PCI slot number of the board associated with this driver block. Use the format **[BusNumber, SlotNumber]**.

To determine the bus number and the PCI slot number, type:

```
tg = slrt;  
getPCIInfo(tg, 'installed')
```

External Websites

- www.milstd1553.com
- www.abaco.com

Condor QPCI-1553 Bus Monitor

Condor QPCI-1553 Bus Monitor (BM) block

Library

Simulink Real-Time Library for MIL-STD-1553

Block Parameters

Channel

From the list of available channels on the board, choose 1, 2, 3, or 4. This channel is initialized for this command stream.

Maximum number of messages to receive

Enter the maximum number of messages this block must read from the board.

Sample time

Enter the base sample time or a multiple of the base sample time (-1 means sample time is inherited).

PCI slot (-1:autosearch)

If only one board of this type is in the target computer, enter -1 to locate the board.

If two or more boards of this type are in the target computer, enter the bus number and the PCI slot number of the board associated with this driver block. Use the format **[BusNumber, SlotNumber]**.

To determine the bus number and the PCI slot number, type:

```
tg = slrt;  
getPCIInfo(tg, 'installed')
```

External Websites

- www.milstd1553.com
- www.abaco.com

Condor QPCI-1553 Initialize

Condor QPCI-1553 Initialize block

Library

Simulink Real-Time Library for MIL-STD-1553

Block Parameters

Channel

From the list of available channels on the board, choose 1, 2, 3, or 4. This channel is initialized for this command stream.

Loopback enabled

Select this check box to route signals to the test bus on the board. This bus provides a loopback connection between the four channels on the board that does not require external wiring.

Coupling mode

From the list, select from **Direct Coupling** and **Transformer Coupling**. This selection defines the mode for coupling a terminal device to the bus.

Initialize for Bus Controller operation

Select this check box to perform Bus Controller initialization for this channel. Selecting this check box enables the parameters **Number of Bus Controller buffers to allocate**, **Enable retries**, **No response timeout (microseconds)**, and **Late response timeout (microseconds)**.

Number of Bus Controller buffers to allocate

Enter the number of buffers to allocate in onboard memory on the board. This number must be greater than or equal to the longest string of command buffers that the board is given to process.

Enable retries

Select this check box to enable automatic retries when a message times out or has an error.

No response timeout (microseconds)

Enter the number of microseconds the board is to wait for a response from the Remote Terminal. If the response from the Remote Terminal takes longer than this timeout value, the board sets the NORESPONSE error condition in the status returned from the command.

Late response timeout (microseconds)

Enter the number of microseconds the board is to wait for a response from the Remote Terminal. If the response from the Remote Terminal takes longer than this timeout value, the board sets the LATERESPONSE error condition in the status returned from the command.

Initialize for Bus Monitor operation

Select this check box to initialize this channel for Bus Monitor operation. Selecting this check box enables the parameters **Monitor bus A**, **Monitor bus B**, and **Number of monitor buffers to allocate**.

Monitor bus A

Select this check box to monitor bus A. You can monitor either bus A, bus B, or both.

Monitor bus B

Select this check box to monitor bus B. You can monitor either bus B, bus A, or both.

Number of monitor buffers to allocate

Enter a number at least as large as the number of messages that you expect to see between calls to the Bus Monitor block. If more messages arrive than there are buffers, some messages are lost and not monitored.

Initialize for Remote Terminal operation

Select this check box to prepare the board to operate as a Remote Terminal. If you select this check box, add the RT Initialize block to the model to initialize the Remote Terminal. Connect the RT Initialize block for the Remote Terminal to the S output of this block.

Selecting this check box enables the parameter **RT address 31 is Broadcast**.

RT address 31 is Broadcast

Select this check box to enable the board to see messages to Remote Terminal 31 as broadcast messages.

Sample time

Enter the base sample time or a multiple of the base sample time (- 1 means sample time is inherited).

PCI slot (-1:autosearch)

If only one board of this type is in the target computer, enter - 1 to locate the board.

If two or more boards of this type are in the target computer, enter the bus number and the PCI slot number of the board associated with this driver block. Use the format **[BusNumber,SlotNumber]**.

To determine the bus number and the PCI slot number, type:

```
tg = slrt;  
getPCIInfo(tg, 'installed')
```

External Websites

- www.milstd1553.com
- www.abaco.com

Condor QPCI-1553 RT Initialize

Condor QPCI-1553 RT Initialize block

Library

Simulink Real-Time Library for MIL-STD-1553

Description

Add an RT Initialize block for each Remote Terminal address for which you want this board to accept commands. Because each of these blocks must execute after the global board initialization, connect the **S** input to either the:

- Main Condor QPCI-1553 Initialize block for this board
- Another Condor QPCI-1553 RT Initialize block that is connected to the main Condor QPCI-1553 Initialize block

This connection carries the channel number and PCI slot information.

Block Parameters

Remote Terminal

From the list, choose a Remote Terminal from 0 to 31. The remote terminal number configured in RT Send and RT Receive must match that specified by the corresponding RT Initialize block.

Connect to bus A

Select this check box to have this Remote Terminal listen on bus A. If a message can come in on either bus, choose both A and B.

Connect to bus B

Select this check box to have this Remote Terminal listen on bus B. If a message can come in on either bus, choose both A and B.

Initial status

Enter the value to which the board should initialize the status before it executes commands. The board maintains a status word that it sends to the Bus Controller after it executes a command.

Initial BIT word

Enter the initial value of the Built In Test (BIT) word. The Remote Terminal sends this word in response to the Transmit BIT Word mode code.

Inhibit terminal flag

Select this check box to inhibit the Remote Terminal flag. This value is the initial value of the Inhibit Terminal Flag bit. This value can be changed from the Bus Controller with the Inhibit Terminal and Override Inhibit Terminal mode codes. The terminal bit is one of the bits in the status word that is maintained by the I/O module.

Transmit sub addresses

Enter a vector of sub addresses to which this Remote Terminal must respond. These sub addresses are the sub addresses that can transmit data when requested. Each element of the vector must correspond to the corresponding element of the **Legal transmit message lengths** vector. To enable the sub address for the Remote Terminal, include the sub address in the vector.

A Remote Terminal accepts a message only if it has been directed to accept messages of the same length. During initialization, the board must receive a list of valid message lengths for each Remote Terminal number.

Legal transmit message lengths

Enter a vector of transmit message lengths. This vector is a vector of bit masks. Each mask bit corresponds to a single message length. Construct the transmit message length vector as follows:

- Each element of the vector corresponds to the corresponding element of the **Transmit sub addresses** vector.
- Each element of the vector corresponds to the corresponding element of the **Legal receive message lengths**. Failure to do so prevents the sub address on this Remote Terminal from responding.

A message can have a length of from 1 to 32 words, selected by setting one or more bits in a 32-bit mask.

Bit Position	Mask Value (hex)	Word Length (words)
0	0x00000001	32

Bit Position	Mask Value (hex)	Word Length (words)
1	0x00000002	1
2	0x00000004	2
...		
30	0x40000000	30
31	0x80000000	31

- Use the `hex2dec` function to specify the bit mask in hexadecimal.
- The message length is expressed by bit position in the mask, not by mask value. The value `0xffffffff` enables all message lengths from 1 to 32.
- The board does not accept a message with a disallowed length. The board sends an error to the Bus Controller by returning a status with the Message Error bit set.

Receive sub addresses

Enter a vector of the sub addresses that can accept a receive message. Each element of the vector must correspond to the corresponding element of the **Legal receive message lengths** vector. To enable the sub address for the Remote Terminal, include the sub address in the vector.

A Remote Terminal accepts a message only if it has been directed to accept messages of the same length. During initialization, the board must receive a list of valid message lengths for each Remote Terminal number.

Legal receive message lengths

Enter a vector of receive message lengths. This vector is a vector of bit masks. Each bit corresponds to a single message length. Construct the receive message lengths vector as follows:

- Each element of the vector corresponds to the corresponding element of the **Transmit sub addresses** vector.
- Each element of the vector corresponds to the corresponding element of the **Receive sub addresses** vector.
- Each element of the vector corresponds to the corresponding element of the **Legal transmit message lengths**. Failure to do so prevents the sub address on this Remote Terminal from responding.

A message can have a length of from 1 to 32 words, selected by setting one or more bits in a 32-bit mask.

Bit Position	Mask Value (hex)	Word Length (words)
0	0x00000001	32
1	0x00000002	1
2	0x00000004	2
...		
30	0x40000000	30
31	0x80000000	31

- Use the `hex2dec` function to specify the bit mask in hexadecimal.
- The message length is expressed by bit position in the mask, not by mask value. The value `0xffffffff` enables all message lengths from 1 to 32.
- The board does not accept a message with a disallowed length. The board sends an error to the Bus Controller by returning a status with the Message Error bit set.

Sample time

Enter the base sample time or a multiple of the base sample time (- 1 means sample time is inherited).

External Websites

- www.milstd1553.com
- www.abaco.com

Condor QPCI-1553 RT Receive

Condor QPCI-1553 RT Receive block for remote terminal

Library

Simulink Real-Time Library for MIL-STD-1553

Note

Your model might have multiple Remote Terminal Receive blocks. To help you locate a particular block, the Remote Terminal Receive block displays the channel number and address parameters. The address display has the format:

```
remote terminal-R-sub address-number of words
```

Remote terminal — Is the **Remote Terminal** parameter

R — Indicates receive command

Subaddress — Is the **Sub address** parameter

Number of words — Is the **Number of words to receive** parameter

A receive command for RT 1, sub address 3 to receive 2 words has the layout 1-R-3-2.

Block Parameters

Channel

From the list of available channels on the board, choose 1, 2, 3, or 4. This channel is initialized for this command stream.

Remote Terminal

From the list, choose a Remote Terminal from 0 to 31. The remote terminal number configured in RT Send and RT Receive must match that specified by the corresponding RT Initialize block.

Sub address

From the list, choose a sub address from 0 to 31. Select the sub address for this message.

Number of words to receive

Enter the number of 16-bit integers to receive as the data part of this message. This number must be between 1 and 32. The output data vector has the same vector width.

If this Remote Terminal or sub address can be sent messages with different lengths, specify the longest message length for this parameter. You must determine how much length is significant from content.

Enable timestamp output

Select this check box to cause output T to appear.

Output T returns the time, in microseconds, at which the most recent message was received. The time is measured from the beginning of execution.

Sample time

Enter the base sample time or a multiple of the base sample time (- 1 means sample time is inherited).

PCI slot (-1:autosearch)

If only one board of this type is in the target computer, enter - 1 to locate the board.

If two or more boards of this type are in the target computer, enter the bus number and the PCI slot number of the board associated with this driver block. Use the format [**BusNumber,SlotNumber**].

To determine the bus number and the PCI slot number, type:

```
tg = slrt;  
getPCIInfo(tg, 'installed')
```

External Websites

- www.milstd1553.com
- www.abaco.com

Condor QPCI-1553 RT Send

Condor QPCI-1553 RT Send block for remote terminal

Library

Simulink Real-Time Library for MIL-STD-1553

Description

A Remote Terminal sends data only if it receives a transmit command from the Bus Controller. This block prepares the board for the next transmit command on this channel, Remote Terminal number, and sub address as specified by the Initialize and RT Initialize blocks.

The data vector signal input to this block is copied to the board message buffer that corresponds to the specified address. The input data vector must have the same length as specified in the **Number of words to send** parameter. The input vector can be either 16- or 32-bit signed or unsigned data. The block sends only the bottom 16 bits of each element.

Your model might have multiple Remote Terminal Send blocks. To help you locate a particular block, the Remote Terminal Send block displays the channel number and address parameters. The address display has the format:

```
remote terminal-T-sub address-number of words
```

Remote terminal — Is the **Remote Terminal** parameter

T — Indicates transmit (or send) command

Subaddress — Is the **Sub address** parameter

Number of words — Is the **Number of words to receive** parameter

A transmit command for RT 1, sub address 3 to send 2 words has the layout 1 - T - 3 - 2.

Block Parameters

Channel

From the list of available channels on the board, choose 1, 2, 3, or 4. This channel is initialized for this command stream.

Remote Terminal

From the list, choose a Remote Terminal from 0 to 31. The remote terminal number configured in RT Send and RT Receive must match that specified by the corresponding RT Initialize block.

Sub address

From the list, choose a sub address from 0 to 31. Select the sub address for this message.

Number of words to send

Enter the number of 16-bit integers to send as the data part of this message. This number must be between 1 and 32. The input data vector must have the same vector width.

Sample time

Enter the base sample time or a multiple of the base sample time (- 1 means sample time is inherited).

PCI slot (-1:autosearch)

If only one board of this type is in the target computer, enter - 1 to locate the board.

If two or more boards of this type are in the target computer, enter the bus number and the PCI slot number of the board associated with this driver block. Use the format **[BusNumber, SlotNumber]**.

To determine the bus number and the PCI slot number, type:

```
tg = slrt;  
getPCIInfo(tg, 'installed')
```

External Websites

- www.milstd1553.com
- www.abaco.com

Condor QPCX-1553

Support for MIL-STD-1553 QPCX boards

Board

Condor QPCX-1553

General Description

The MIL-STD-1553 driver library allows real-time applications to connect to a MIL-STD-1553 bus network to send and receive messages of up to 32 16-bit words. You must be familiar with the MIL-STD-1553 standard.

The Simulink Real-Time block library supports the MIL-STD-1553 protocol with QPCX-1553 boards. These boards connect a target computer to a MIL-STD-1553 data bus via the high-density PCX (QPCX) bus.

The QPCX-1553 board is available with 1, 2, 3, or 4 channels as either a single function or multifunction configuration. The multifunction version supports simultaneous use of the Bus Controller, Bus Monitor, and Remote Terminal functions. The single function version emits an error if more than one function is initialized. This board also supports a loopback mode for testing. QPCX-1553 blocks support up to four channels for this board.

To support these boards, the block library provides the following driver blocks:

- Condor QPCX-1553 Bus Controller Send
- Condor QPCX-1553 Bus Monitor
- Condor QPCX-1553 Initialize
- Condor QPCX-1553 RT Initialize
- Condor QPCX-1553 RT Receive
- Condor QPCX-1553 RT Send

To format the Bus Controller messages, use the following utility blocks:

- Condor 1553 Create BC Message List

- Condor 1553 Decode BC Message
- Condor 1553 Decode BC Status
- Condor 1553 Encode BC Message
- Condor 1553 Select BM Message

Board Characteristics

Board name	QPCX-1553
Manufacturer	GE Fanuc (formerly Condor Engineering)
Bus type	QPCX
Multiple board support	Yes

External Websites

- www.milstd1553.com
- www.abaco.com

Condor QPCX-1553 Bus Controller Send

Condor QPCX-1553 BC Send block for bus controller

Library

Simulink Real-Time Library for MIL-STD-1553

Description

This block sends a list of messages to the specified channel on the board. Before you construct the list of messages:

- 1 Allocate space for the list with the Condor 1553 Create BC Message List block.
- 2 Fill in information about each message with Condor 1553 Encode BC Message blocks.

Each instance of an Encode BC Message block fills in information for a single message on the list. Daisy-chain the Encode BC Message block L signals so the Encode BC blocks execute before the Bus Controller Send block.

The Bus Controller Send block allocates a list for the reception of messages. This block can:

- Read the set of messages and statuses from the last time a message was sent before sending the new list.
- Send the new list and wait for a response.

In other words, for time step N, the output of the Send block is either the response to time step N-1 or the response to time step N, chosen from the **Response mode** parameter.

Block Parameters

Channel

From the list of available channels on the board, choose 1, 2, 3, or 4. This channel is initialized for this command stream.

Response mode

Choose from:

- **Read response to previous message then send new message** — Before sending new messages, read the command buffers from the board.
- **Send new message then wait and read response** — Transmit new message, and then wait for response before continuing.

Use the **Maximum wait time (microseconds)** parameter to set the amount of time the block must wait for a response.

Maximum wait time (microseconds)

Enter the maximum time that this block waits for the message stream to be sent by the board. If the **Response mode** parameter is set to **Send new message then wait and read response**, use this parameter.

A reasonable maximum wait time is 1000 microseconds (1 millisecond). This value must not exceed the sample time. Exceeding the sample time triggers an execution overload.

Sample time

Enter the base sample time or a multiple of the base sample time (- 1 means sample time is inherited).

PCI slot (-1:autosearch)

If only one board of this type is in the target computer, enter - 1 to locate the board.

If two or more boards of this type are in the target computer, enter the bus number and the PCI slot number of the board associated with this driver block. Use the format **[BusNumber, SlotNumber]**.

To determine the bus number and the PCI slot number, type:

```
tg = slrt;  
getPCIInfo(tg, 'installed')
```

External Websites

- www.milstd1553.com
- www.abaco.com

Condor QPCX-1553 Bus Monitor

Condor QPCX-1553 Bus Monitor (BM) block

Library

Simulink Real-Time Library for MIL-STD-1553

Block Parameters

Channel

From the list of available channels on the board, choose 1, 2, 3, or 4. This channel is initialized for this command stream.

Maximum number of messages to receive

Enter the maximum number of messages this block must read from the board.

Sample time

Enter the base sample time or a multiple of the base sample time (-1 means sample time is inherited).

PCI slot (-1:autosearch)

If only one board of this type is in the target computer, enter -1 to locate the board.

If two or more boards of this type are in the target computer, enter the bus number and the PCI slot number of the board associated with this driver block. Use the format **[BusNumber, SlotNumber]**.

To determine the bus number and the PCI slot number, type:

```
tg = slrt;  
getPCIInfo(tg, 'installed')
```

External Websites

- www.milstd1553.com
- www.abaco.com

Condor QPCX-1553 Initialize

Condor QPCX-1553 Initialize block

Library

Simulink Real-Time Library for MIL-STD-1553

Block Parameters

Channel

From the list of available channels on the board, choose 1, 2, 3, or 4. This channel is initialized for this command stream.

Loopback enabled

Select this check box to route signals to the test bus on the board. This bus provides a loopback connection between the four channels on the board that does not require external wiring.

Coupling mode

From the list, select from **Direct Coupling** and **Transformer Coupling**. This selection defines the mode for coupling a terminal device to the bus.

Output voltage

Enter the required output voltage, in volts. The output voltage range depends on the coupling mode.

- **Direct Coupling** — 0–6.5 V
- **Transformer Coupling** — 0–19.8 V

Initialize for Bus Controller operation

Select this check box to perform Bus Controller initialization for this channel. Selecting this check box enables the parameters **Number of Bus Controller buffers to allocate**, **Enable retries**, **No response timeout (microseconds)**, and **Late response timeout (microseconds)**.

Number of Bus Controller buffers to allocate

Enter the number of buffers to allocate in onboard memory on the board. This number must be greater than or equal to the longest string of command buffers that the board is given to process.

Enable retries

Select this check box to enable automatic retries when a message times out or has an error.

No response timeout (microseconds)

Enter the number of microseconds the board is to wait for a response from the Remote Terminal. If the response from the Remote Terminal takes longer than this timeout value, the board sets the NORESPONSE error condition in the status returned from the command.

Late response timeout (microseconds)

Enter the number of microseconds the board is to wait for a response from the Remote Terminal. If the response from the Remote Terminal takes longer than this timeout value, the board sets the LATERESPONSE error condition in the status returned from the command.

Initialize for Bus Monitor operation

Select this check box to initialize this channel for Bus Monitor operation. Selecting this check box enables the parameters **Monitor bus A**, **Monitor bus B**, and **Number of monitor buffers to allocate**.

Monitor bus A

Select this check box to monitor bus A. You can monitor either bus A, bus B, or both.

Monitor bus B

Select this check box to monitor bus B. You can monitor either bus B, bus A, or both.

Number of monitor buffers to allocate

Enter a number at least as large as the number of messages that you expect to see between calls to the Bus Monitor block. If more messages arrive than there are buffers, some messages are lost and not monitored.

Initialize for Remote Terminal operation

Select this check box to prepare the board to operate as a Remote Terminal. If you select this check box, add the RT Initialize block to the model to initialize the Remote

Terminal. Connect the RT Initialize block for the Remote Terminal to the S output of this block.

Selecting this check box enables the parameter **RT address 31 is Broadcast**.

RT address 31 is Broadcast

Select this check box to enable the board to see messages to Remote Terminal 31 as broadcast messages.

Sample time

Enter the base sample time or a multiple of the base sample time (- 1 means sample time is inherited).

PCI slot (-1:autosearch)

If only one board of this type is in the target computer, enter - 1 to locate the board.

If two or more boards of this type are in the target computer, enter the bus number and the PCI slot number of the board associated with this driver block. Use the format [**BusNumber,SlotNumber**].

To determine the bus number and the PCI slot number, type:

```
tg = slrt;  
getPCIInfo(tg, 'installed')
```

External Websites

- www.milstd1553.com
- www.abaco.com

Condor QPCX-1553 RT Initialize

Condor QPCX-1553 RT Initialize block

Library

Simulink Real-Time Library for MIL-STD-1553

Description

Add an RT Initialize block for each Remote Terminal address for which you want this board to accept commands. Because each of these blocks must execute after the global board initialization, connect the **S** input to either the:

- Main Condor QPCX-1553 Initialize block for this board
- Another Condor QPCX-1553 RT Initialize block that is connected to the main Condor QPCX-1553 Initialize block

This connection carries the channel number and PCI slot information.

Block Parameters

Remote Terminal

From the list, choose a Remote Terminal from 0 to 31. The remote terminal number configured in RT Send and RT Receive must match that specified by the corresponding RT Initialize block.

Connect to bus A

Select this check box to have this Remote Terminal listen on bus A. If a message can come in on either bus, choose both A and B.

Connect to bus B

Select this check box to have this Remote Terminal listen on bus B. If a message can come in on either bus, choose both A and B.

Initial status

Enter the value to which the board should initialize the status before it executes commands. The board maintains a status word that it sends to the Bus Controller after it executes a command.

Initial BIT word

Enter the initial value of the Built In Test (BIT) word. The Remote Terminal sends this word in response to the Transmit BIT Word mode code.

Inhibit terminal flag

Select this check box to inhibit the Remote Terminal flag. This value is the initial value of the Inhibit Terminal Flag bit. This value can be changed from the Bus Controller with the Inhibit Terminal and Override Inhibit Terminal mode codes. The terminal bit is one of the bits in the status word that is maintained by the I/O module.

Transmit sub addresses

Enter a vector of sub addresses to which this Remote Terminal must respond. These sub addresses are the sub addresses that can transmit data when requested. Each element of the vector must correspond to the corresponding element of the **Legal transmit message lengths** vector. To enable the sub address for the Remote Terminal, include the sub address in the vector.

A Remote Terminal accepts a message only if it has been directed to accept messages of the same length. During initialization, the board must receive a list of valid message lengths for each Remote Terminal number.

Legal transmit message lengths

Enter a vector of transmit message lengths. This vector is a vector of bit masks. Each mask bit corresponds to a single message length. Construct the transmit message length vector as follows:

- Each element of the vector corresponds to the corresponding element of the **Transmit sub addresses** vector.
- Each element of the vector corresponds to the corresponding element of the **Legal receive message lengths**. Failure to do so prevents the sub address on this Remote Terminal from responding.

A message can have a length of from 1 to 32 words, selected by setting one or more bits in a 32-bit mask.

Bit Position	Mask Value (hex)	Word Length (words)
0	0x00000001	32

Bit Position	Mask Value (hex)	Word Length (words)
1	0x00000002	1
2	0x00000004	2
...		
30	0x40000000	30
31	0x80000000	31

- Use the `hex2dec` function to specify the bit mask in hexadecimal.
- The message length is expressed by bit position in the mask, not by mask value. The value `0xffffffff` enables all message lengths from 1 to 32.
- The board does not accept a message with a disallowed length. The board sends an error to the Bus Controller by returning a status with the Message Error bit set.

Receive sub addresses

Enter a vector of the sub addresses that can accept a receive message. Each element of the vector must correspond to the corresponding element of the **Legal receive message lengths** vector. To enable the sub address for the Remote Terminal, include the sub address in the vector.

A Remote Terminal accepts a message only if it has been directed to accept messages of the same length. During initialization, the board must receive a list of valid message lengths for each Remote Terminal number.

Legal receive message lengths

Enter a vector of receive message lengths. This vector is a vector of bit masks. Each bit corresponds to a single message length. Construct the receive message lengths vector as follows:

- Each element of the vector corresponds to the corresponding element of the **Transmit sub addresses** vector.
- Each element of the vector corresponds to the corresponding element of the **Receive sub addresses** vector.
- Each element of the vector corresponds to the corresponding element of the **Legal transmit message lengths**. Failure to do so prevents the sub address on this Remote Terminal from responding.

A message can have a length of from 1 to 32 words, selected by setting one or more bits in a 32-bit mask.

Bit Position	Mask Value (hex)	Word Length (words)
0	0x00000001	32
1	0x00000002	1
2	0x00000004	2
...		
30	0x40000000	30
31	0x80000000	31

- Use the `hex2dec` function to specify the bit mask in hexadecimal.
- The message length is expressed by bit position in the mask, not by mask value. The value `0xffffffff` enables all message lengths from 1 to 32.
- The board does not accept a message with a disallowed length. The board sends an error to the Bus Controller by returning a status with the Message Error bit set.

Sample time

Enter the base sample time or a multiple of the base sample time (- 1 means sample time is inherited).

External Websites

- www.milstd1553.com
- www.abaco.com

Condor QPCX-1553 RT Receive

Condor QPCX-1553 RT Receive block for remote terminal

Library

Simulink Real-Time Library for MIL-STD-1553

Note

Your model can have multiple Remote Terminal Receive blocks. To help you locate a particular block, the Remote Terminal Receive block displays the channel number and address parameters. The address display has the format:

```
remote terminal-R-sub address-number of words
```

Remote terminal — Is the **Remote Terminal** parameter

R — Indicates receive command

Subaddress — Is the **Sub address** parameter

Number of words — Is the **Number of words to receive** parameter

A receive command for RT 1, sub address 3 to receive 2 words has the layout 1-R-3-2.

Block Parameters

Channel

From the list of available channels on the board, choose 1, 2, 3, or 4. This channel is initialized for this command stream.

Remote Terminal

From the list, choose a Remote Terminal from 0 to 31. The remote terminal number configured in RT Send and RT Receive must match that specified by the corresponding RT Initialize block.

Sub address

From the list, choose a sub address from 0 to 31. Select the sub address for this message.

Number of words to receive

Enter the number of 16-bit integers to receive as the data part of this message. This number must be between 1 and 32. The output data vector has the same vector width.

If this Remote Terminal or sub address can be sent messages with different lengths, specify the longest message length for this parameter. You must determine how much length is significant from content.

Enable timestamp output

Select this check box to cause output T to appear.

Output T returns the time, in microseconds, at which the most recent message was received. The time is measured from the beginning of execution.

Sample time

Enter the base sample time or a multiple of the base sample time (- 1 means sample time is inherited).

PCI slot (-1:autosearch)

If only one board of this type is in the target computer, enter - 1 to locate the board.

If two or more boards of this type are in the target computer, enter the bus number and the PCI slot number of the board associated with this driver block. Use the format [**BusNumber,SlotNumber**].

To determine the bus number and the PCI slot number, type:

```
tg = slrt;  
getPCIInfo(tg, 'installed')
```

External Websites

- www.milstd1553.com
- www.abaco.com

Condor QPCX-1553 RT Send

Condor QPCX-1553 RT Send block for remote terminal

Library

Simulink Real-Time Library for MIL-STD-1553

Description

A Remote Terminal sends data only if it receives a transmit command from the Bus Controller. This block prepares the board for the next transmit command on this channel, Remote Terminal number, and sub address as specified by the Initialize and RT Initialize blocks.

The data vector signal input to this block is copied to the board message buffer that corresponds to the specified address. The input data vector must have the same length as specified in the **Number of words to send** parameter. The input vector can be either 16- or 32-bit signed or unsigned data. The block sends only the bottom 16 bits of each element.

Your model can have multiple Remote Terminal Send blocks. To help you locate a particular block, the Remote Terminal Send block displays the channel number and address parameters. The address display has the format:

```
remote terminal-T-sub address-number of words
```

Remote terminal — Is the **Remote Terminal** parameter

T — Indicates transmit (or send) command

Subaddress — Is the **Sub address** parameter

Number of words — Is the **Number of words to receive** parameter

A transmit command for RT 1, sub address 3 to send 2 words has the layout 1 - T - 3 - 2.

Block Parameters

Channel

From the list of available channels on the board, choose 1, 2, 3, or 4. This channel is initialized for this command stream.

Remote Terminal

From the list, choose a Remote Terminal from 0 to 31. The remote terminal number configured in RT Send and RT Receive must match that specified by the corresponding RT Initialize block.

Sub address

From the list, choose a sub address from 0 to 31. Select the sub address for this message.

Number of words to send

Enter the number of 16-bit integers to send as the data part of this message. This number must be between 1 and 32. The input data vector must have the same vector width.

Sample time

Enter the base sample time or a multiple of the base sample time (- 1 means sample time is inherited).

PCI slot (-1:autosearch)

If only one board of this type is in the target computer, enter - 1 to locate the board.

If two or more boards of this type are in the target computer, enter the bus number and the PCI slot number of the board associated with this driver block. Use the format **[BusNumber, SlotNumber]**.

To determine the bus number and the PCI slot number, type:

```
tg = slrt;  
getPCIInfo(tg, 'installed')
```

External Websites

- www.milstd1553.com
- www.abaco.com

GE Fanuc PCI-5565

Support for GE Fanuc PCI-5565 high-speed fiber optic reflective memory boards

Board

GE Fanuc PCI-5565

General Description

The VMIPCI-5565 and PCI-5565PIORC are high-speed fiber optic reflective memory boards. They can also generate/broadcast interrupts. The Simulink Real-Time software uses these boards as part of the shared memory network that you can use to exchange data between computer nodes.

The Simulink Real-Time block library supports these boards with these driver blocks:

- GE Fanuc 5565 broadcast
- GE Fanuc 5565 init
- GE Fanuc 5565 read
- GE Fanuc 5565 write

For information about the Change endianness block, see [Byte Reversal/Change Endianness](#).

Board Characteristics

Board name	VMIPCI-5565, PCI-5565PIORC
Manufacturer	GE Fanuc
Bus type	PCI
Access method	Memory mapped
Multiple block instance support	Yes
Multiple board support	Yes

External Websites

- www.abaco.com

GE Fanuc 5565 broadcast

GE Fanuc PCI-5565 broadcast interrupt block

Library

Simulink Real-Time Library for GE Fanuc (VMIC)

Note

The 5565 broadcast block generates a network interrupt that other boards in the shared memory network can detect.

The 5565 broadcast block has two inputs:

- **En** — This input port is a Boolean input that can enable or disable the transmission of a network interrupt. For continuous interrupts, connect this input port to a Constant block with a Boolean value of true (1). If you want to enable interrupts only part of the time, you can use another kind of input, such as a pulse generator.
- **Data** — This input port allows you to transmit a data value (`uint32`) with the interrupt.

Note: The Simulink Real-Time software does not support receiving this data value.

Block Parameters

Target Node

Enter the node ID of the node to which to broadcast the interrupt. Enter -1 to broadcast the interrupt to the nodes in the shared memory network. You cannot broadcast the interrupt to another subset of nodes.

Interrupt Number

Enter the shared IRQ number. This value is the special interrupt number that two boards use between each other for synchronization (see the LIER register bit descriptions in the PCI-5565 product documentation). This value must match the

value of X in a line like the following, which you specify for the receiving end of the shared memory network (see “Board Interrupts” on page 24-9).

```
node.Interface.Interrupts.PendingIntX
```

Sampletime

Enter the base sample time or a multiple of the base sample time (- 1 means sample time is inherited)

PCI slot (-1:autosearch)

If only one board of this type is in the target computer, enter - 1 to locate the board.

If two or more boards of this type are in the target computer, enter the bus number and the PCI slot number of the board associated with this driver block. Use the format **[BusNumber,SlotNumber]**.

To determine the bus number and the PCI slot number, type:

```
tg = slrt;  
getPCIInfo(tg, 'installed')
```

External Websites

- www.abaco.com

GE Fanuc 5565 init

GE Fanuc PCI-5565 initialization block

Library

Simulink Real-Time Library for GE Fanuc (VMIC)

Note

Before you begin to configure these block parameters, be sure that you have a predefined node initialization structure. See “Initialize GE Fanuc Shared Nodes” on page 24-4.

Each model that uses shared memory must have one 5565 init block for every PCI-5565 board in the system.

Block Parameters

Node struct

Enter the name of the predefined node initialization structure.

PCI slot (-1:autosearch)

If only one board of this type is in the target computer, enter - 1 to locate the board.

If two or more boards of this type are in the target computer, enter the bus number and the PCI slot number of the board associated with this driver block. Use the format [**BusNumber**, **SlotNumber**].

To determine the bus number and the PCI slot number, type:

```
tg = slrt;  
getPCIInfo(tg, 'installed')
```

External Websites

- www.abaco.com

GE Fanuc 5565 read

GE Fanuc PCI-5565 read block

Library

Simulink Real-Time Library for GE Fanuc (VMIC)

Note

Before you begin to configure this block, be sure that you have a predefined shared memory partition structure. The 5565 read block requires this structure to specify how Simulink signal values are mapped in the shared memory. It also uses this structure to determine the total size and address of the shared memory. See “Create GE Fanuc Shared Partitions” on page 24-2.

Block Parameters

Partition struct

Enter the name of the predefined shared memory partition structure. The block uses this structure to specify how Simulink signal values map into shared memory.

Sampletime

Enter the base sample time or a multiple of the base sample time (- 1 means sample time is inherited)

PCI slot (-1:autosearch)

If only one board of this type is in the target computer, enter - 1 to locate the board.

If two or more boards of this type are in the target computer, enter the bus number and the PCI slot number of the board associated with this driver block. Use the format [**BusNumber**, **SlotNumber**].

To determine the bus number and the PCI slot number, type:

```
tg = slrt;  
getPCIInfo(tg, 'installed')
```

Error Status Port

Select this check box to monitor the status of the PCI-5565 board LISR register modes.

External Websites

- www.abaco.com

GE Fanuc 5565 write

GE Fanuc PCI-5565 write block

Library

Simulink Real-Time Library for GE Fanuc (VMIC)

Note

Before you begin to configure this block, be sure that you have a predefined shared memory partition structure. The 5565 write block requires this structure to specify how Simulink signal values are mapped in the shared memory. It also uses this structure to determine the total size and address of the shared memory. See “Create GE Fanuc Shared Partitions” on page 24-2.

Block Parameters

Partition struct

Enter the name of the predefined shared memory partition structure. The block uses this structure to specify how Simulink signal values map into shared memory.

Sampletime

Enter the base sample time or a multiple of the base sample time (- 1 means sample time is inherited)

PCI slot (-1:autosearch)

If only one board of this type is in the target computer, enter - 1 to locate the board.

If two or more boards of this type are in the target computer, enter the bus number and the PCI slot number of the board associated with this driver block. Use the format [**BusNumber**, **SlotNumber**].

To determine the bus number and the PCI slot number, type:

```
tg = slrt;  
getPCIInfo(tg, 'installed')
```

Error Status Port

Select this check box to monitor the status of the PCI-5565 board LISR register modes.

External Websites

- www.abaco.com

SBS 2510/2500 Broadcast Memory

Support for the SBS 2510/2500 Broadcast Memory board

Board

SBS 2510/2500 Broadcast Memory

General Description

The SBS 2510/2500 Broadcast Memory board is a high-speed fiber optic reflective memory. It can also generate/broadcast interrupts. The Simulink Real-Time software uses this board as part of the shared memory network that you can use to exchange data between computer nodes.

The Simulink Real-Time block library supports this board with these driver blocks:

- SBS25x0 init
- SBS25x0 read
- SBS25x0 write

For information about the Change endianness block, see [Byte Reversal/Change Endianness](#).

Board Characteristics

Board name	SBS Broadcast Memory
Manufacturer	SBS
Bus type	PCI
Access method	Memory mapped
Multiple block instance support	Yes
Multiple board support	Yes

External Websites

- www.abaco.com

SBS25x0 init

SBS25x0 init block

Library

Simulink Real-Time Library for SBS Broadcast Memory

Block Parameters

Before you begin to configure these block parameters, be sure that you have a predefined node initialization structure. See “Initialize GE Intelligent Platforms Shared Nodes” on page 24-17.

Each model that uses shared memory must have one 5565 init block for every SBS Broadcast Memory board in the system.

Node struct

Enter the name of the predefined node initialization structure.

PCI slot (-1:autosearch)

If only one board of this type is in the target computer, enter -1 to locate the board.

If two or more boards of this type are in the target computer, enter the bus number and the PCI slot number of the board associated with this driver block. Use the format [**BusNumber,SlotNumber**].

To determine the bus number and the PCI slot number, type:

```
tg = slrt;  
getPCIInfo(tg, 'installed')
```

External Websites

- www.abaco.com

SBS25x0 read

SBS25x0 read block

Library

Simulink Real-Time Library for SBS Broadcast Memory

Block Parameters

Before you begin to configure this block, be sure that you have a predefined shared memory partition structure. The 5565 read block requires this structure to specify how Simulink signal values are mapped in the shared memory. It also uses this structure to determine the total size and address of the shared memory. See “Create GE Intelligent Platforms Shared Partitions” on page 24-14.

Partition struct

Enter the name of the predefined shared memory partition structure. The block uses this structure to specify how Simulink signal values map into shared memory.

Sampletime

Enter the base sample time or a multiple of the base sample time (- 1 means sample time is inherited)

PCI slot (-1:autosearch)

If only one board of this type is in the target computer, enter - 1 to locate the board.

If two or more boards of this type are in the target computer, enter the bus number and the PCI slot number of the board associated with this driver block. Use the format [**BusNumber**,**SlotNumber**].

To determine the bus number and the PCI slot number, type:

```
tg = slrt;  
getPCIInfo(tg, 'installed')
```

Error Status Port

Select this check box to monitor the status of the SBS Broadcast Memory board LIER register modes.

External Websites

- www.abaco.com

SBS25x0 write

SBS25x0 write block

Library

Simulink Real-Time Library for SBS Broadcast Memory

Block Parameters

Before you begin to configure this block, be sure that you have a predefined shared memory partition structure. The 5565 write block requires this structure to specify how Simulink signal values are mapped in the shared memory. It also uses this structure to determine the total size and address of the shared memory. See “Create GE Intelligent Platforms Shared Partitions” on page 24-14.

Partition struct

Enter the name of the predefined shared memory partition and object. The block uses this structure to specify how Simulink signal values map into shared memory.

Sampletime

Enter the base sample time or a multiple of the base sample time (- 1 means sample time is inherited)

PCI slot (-1:autosearch)

If only one board of this type is in the target computer, enter - 1 to locate the board.

If two or more boards of this type are in the target computer, enter the bus number and the PCI slot number of the board associated with this driver block. Use the format [**BusNumber**, **SlotNumber**].

To determine the bus number and the PCI slot number, type:

```
tg = slrt;
getPCIInfo(tg, 'installed')
```

Error Status Port

Select this check box to monitor the status of the SBS Broadcast Memory board LIER register modes.

External Websites

- www.abaco.com

SBS IP-DAC

Support for the SBS IP-DAC I/O board

Board

SBS IP-DAC

General Description

The IP-DAC I/O board has 6 independent precalibrated analog output (D/A) channels (12-bit).

The Simulink Real-Time block library supports this board with this driver blocks:

- SBS IP-DAC Analog Output (D/A)

Board Characteristics

Board name	IP-DAC
Manufacturer	GE Intelligent Platforms (formerly SBS Technologies)
Bus type	N/A
Access method	I/O Mapped
Multiple block instance support	Yes
Multiple board support	Yes

External Websites

- www.abaco.com

SBS IP-DAC Analog Output (D/A)

IP-DAC Analog Output block

Library

Simulink Real-Time Library for SBS Broadcast Memory

Scaling Input to Output

Hardware Output	Block Input Data Type	Scaling
Volts	double	1

Block Parameters

Carrier ID

Enter the Carrier ID of the IP carrier board into which the IP module is plugged.

To use an IP module, it must be physically plugged into an IP carrier board and the model must contain a block representing this carrier board. Each carrier block has a **Carrier ID** parameter, which must be set to a number not shared by another carrier board block in the model.

Carrier slot

Select the slot on the carrier board into which the IP-16ADC module is plugged. Different carrier boards can have different slot capacities.

Channel vector

Enter a vector of numbers between 1 and 6. The channel numbers can occur in arbitrary order. For example, to use the first and second analog output (D/A) channels, enter

[1,2]

Number the channels beginning with 1 even if this board manufacturer starts numbering the channels with 0.

Range vector

Enter a range code for each of the channels in the channel vector. The range vector must be the same length as the channel vector. This board allows the range of each channel to be different.

The following table is a list of the ranges for this driver and the corresponding range codes.

Input Range (V)	Range Code
-10 to +10	-10
-5 to +5	-5
-2.5 to +2.5	-2.5
0 to +5	5
0 to +10	10

For example, if the first channel is -10 to +10 volts and the second channel is 0 to +5 volts, enter

`[-10,5]`

The range settings must correspond to the OUTPUT RANGE SELECTION settings on the board for DAC0 and DAC1 (channel 1 and 2, respectively).

Sample time

Enter the base sample time or a multiple of the base sample time (-1 means sample time is inherited).

External Websites

- www.abaco.com

SBS IP-Digital 24

Support for the SBS IP-Digital 24 I/O board

Board

SBS IP-Digital 24

General Description

IP-Digital 24 boards have 24 digital I/O lines which can be independently configured for input or output.

The Simulink Real-Time block library supports this board with these driver blocks:

- SBS IP-Digital 24 Digital Input
- SBS IP-Digital 24 Digital Output

Board Characteristics

Board name	IP-Digital-24
Manufacturer	GE Intelligent Platforms (formerly SBS Technologies)
Bus type	N/A
Access method	I/O Mapped
Multiple block instance support	Yes
Multiple board support	Yes

External Websites

- www.abaco.com

SBS IP-Digital 24 Digital Input

IP-Digital 24 Digital Input block

Library

Simulink Real-Time Library for SBS Broadcast Memory

Scaling Input to Output

Hardware Input	Block Output Data Type	Scaling
TTL	double	TTL low = 0.0 TTL high = 1.0

Block Parameters

Carrier ID

Enter the Carrier ID of the IP carrier board into which the IP module is plugged.

To use an IP module, it must be physically plugged into an IP carrier board and the model must contain a block representing this carrier board. Each carrier block has a **Carrier ID** parameter, which must be set to a number not shared by another carrier board block in the model.

Carrier slot

Select the slot on the carrier board into which the IP-Digital 24 module is plugged. Different carrier boards can have different slot capacities.

Channel vector

Enter numbers between 1 and 24 to select the digital input lines to be used. This driver allows the selection of individual digital input lines in arbitrary order. The number of elements defines the number of lines used.

For example, to use the first three digital inputs, enter

[1,2,3]

Number the lines beginning with 1 even if this board manufacturer starts numbering the lines with 0.

Sample time

Enter the base sample time or a multiple of the base sample time (- 1 means sample time is inherited).

External Websites

- www.abaco.com

SBS IP-Digital 24 Digital Output

IP-Digital 24 Digital Output block

Library

Simulink Real-Time Library for SBS Broadcast Memory

Scaling Input to Output

Hardware Input	Block Output Data Type	Scaling
TTL	double	TTL low = 0.0 TTL high = 1.0

Block Parameters

Carrier ID

Enter the Carrier ID of the IP carrier board into which the IP module is plugged.

To use an IP module, it must be physically plugged into an IP carrier board and the model must contain a block representing this carrier board. Each carrier block has a **Carrier ID** parameter, which must be set to a number not shared by another carrier board block in the model.

Channel vector

Enter numbers between 1 and 24 to select the digital output lines to be used. This driver allows the selection of individual digital output lines in arbitrary order. The number of elements defines the number of lines used.

For example, to use the first three digital outputs, enter

[1,2,3]

Number the lines beginning with 1 even if this board manufacturer starts numbering the lines with 0.

Sample time

Enter the base sample time or a multiple of the base sample time (- 1 means sample time is inherited).

External Websites

- www.abaco.com

SBS IP-UD-IHV-16I80

Support for the SBS IP-UD-IHV-16I80 board

Board

SBS IP-UD-IHV-16I80

General Description

The SBS IP-UD-IHV-16I80 board is an IndustryPack board with 16 inputs and 8 outputs. Each IP module must be physically plugged into an IP carrier board such as the PCI-40B. Models containing IP module blocks must also contain corresponding IP carrier blocks. Each carrier block has a unique **Carrier ID** parameter.

The Simulink Real-Time block library supports this board with these driver blocks:

- SBS IP-UD-IHV-16I80 Digital Input
- SBS IP-UD-IHV-16I80 Digital Output

The following table illustrates the mapping between the SBS IP-UD-IHV-16I80 board lines and the Simulink Real-Time block channels.

Note: In this table, columns **Byte** and **Bit** correspond to the **Format** parameter 8-bit and 1-bit channel modes of the SBS IP-UD-IHV-16I80 Digital Input and SBS IP-UD-IHV-16I80 Digital Output blocks.

SBS Lines	Block Channels		Direction I/O
	Byte	Bit	
1	1	1	Input
2		2	Input
3		3	Input
4		4	Input

SBS Lines	Block Channels		Direction I/O
	Byte	Bit	
5		5	Input
6		6	Input
7		7	Input
8		8	Input
9	2	9	Input
10		10	Input
11		11	Input
12		12	Input
13		13	Input
14		14	Input
15		15	Input
16		16	Input
17	1	1	Output
18		2	Output
19		3	Output
20		4	Output
21		5	Output
22		6	Output
23		7	Output
24		8	Output

Board Characteristics

Board name

SBS IP-UD-IHV-16I80

Manufacturer

GE Intelligent Platforms (formerly SBS Technologies)

Bus type

PCI

Multiple block instance support	No
Multiple board support	Yes

External Websites

- www.abaco.com

SBS IP-UD-IHV-16I80 Digital Input

SBS IP-UD-IHV-16I80 Digital Input block

Library

Simulink Real-Time Library for SBS Technologies

Scaling Input to Output

Hardware Input	Block Output Data Type	Scaling
Volts	Double (Format:16 1-bit Channels)	Double: < Threshold = 0.0 > Threshold = 1.0
	uint8 (Format:Two 8-bit Channels)	uint32: < Threshold, corresponding bit is clear > Threshold, corresponding bit is set

Block Parameters

Carrier ID

Enter a number to uniquely identify this IP carrier board within the model.

Carrier slot

Select the slot on the carrier board into which the module IP-UD-IHV-16I80 is plugged. Different carrier boards can have different slot capacities. From the list, select A, B, C, or D.

Format

From the list, select one of the following modes:

- **16 1-bit Channels**

Configures block to accept up to 16 1-bit channels.

- **Two 8-bit Channels**

Configures block to accept one or two 8-bit channels.

Channel vector

This value depends on the value of **Format**, as follows:

- If you select the **Format** parameter to be **16 1-bit Channels**, enter a vector of numbers between 1 and 16. For example, to use the first and third digital input channels, enter

[1, 3]

- If you select the **Format** parameter to be **Two 8-bit Channels**, enter a vector of numbers between 1 and 2. For example, to use the first and second digital input channels, enter

[1, 2]

Note: The manufacturer numbers its lines sequentially from 1 to 24, regardless of the line's function. The input lines of this board are numbered 1 to 16. For Simulink Real-Time blocks, the channel numbers depend on the setting of the **Format** parameter. If you select the **Format** parameter to be **16 1-bit Channels** (bit mode), the channel numbers range from 1 to 16. If you select the **Format** parameter to be **Two 8-bit Channels** (byte mode), the channel numbers range from 1 to 2. See the mapping table in **SBS IP-UD-IHV-16I80**.

Threshold

Enter a threshold value. This block reads the input as 1 if the input voltage multiplied by the operational amplifier (op amp) gain is greater than this threshold value. This block reads the input as 0 if the input voltage is less than this threshold value.

The maximum value of **Threshold** is 61.68 volts. It has a granularity of 15 millivolts. See the IP-UD-IHV user documentation for details.

Sample time

Enter the base sample time or a multiple of the base sample time (- 1 means sample time is inherited).

External Websites

- www.abaco.com

SBS IP-UD-IHV-16I80 Digital Output

SBS IP-UD-IHV-16I80 Digital Output block

Library

Simulink Real-Time Library for SBS Technologies

Scaling of Output to Input

Hardware Input	Block Output Data Type	Scaling
Volts	Double (Format:8 1-bit Channels)	Double: < 0.5, off >0.5, on
	uint8 (Format:One 8-bit Channel)	uint32: Bit clear, off Bit set, on

Block Parameters

Carrier ID

Enter a number to uniquely identify this IP carrier board within the model.

Carrier slot

Select the slot on the carrier board into which the module IP-UD-IHV-16I80 is plugged. Different carrier boards can have different slot capacities. From the list, select A, B, C, or D.

Format

From the list, select one of the following modes:

- 8 1-bit Channels

Configures block to accept up to eight 1-bit channels.

- One 8-bit Channels

Configures block to accept one 8-bit channels.

Channel vector

This value depends on the value of **Format**, as follows:

- Vector of numbers between 1 and 16

If you select the **Format** parameter to be **8 1-bit Channels**. For example, to use the first and third digital input channels, enter

```
[1, 3]
```

- Vector of 1

If you select the **Format** parameter to be **One 8-bit Channel**. For example, to use the first and second digital input channels, enter

```
[1]
```

Note: The manufacturer numbers its lines sequentially from 1 to 24, regardless of the line's function. The output lines of this board are numbered 17 to 24. For Simulink Real-Time blocks, the channel numbers depend on the setting of the **Format** parameter. If you select the **Format** parameter to be **8 1-bit Channels** (bit mode), the channel numbers range from 1 to 8. If you select the **Format** parameter to be **Two 8-bit Channels** (byte mode), the channel number is 1. See the mapping table in SBS IP-UD-IHV-16I80.

Initial value vector

The initial value vector contains the initial voltage values for the output channels.

Enter a scalar or a vector that is the same length as the channel vector. If you specify a scalar value, that value is replicated as the initial value over the channel vector.

The channels are set to the initial values between the time the model is downloaded and the time it is started.

Final action vector

The final action vector controls the behavior of the channel at model termination.

Enter a scalar or a vector that is the same length as the channel vector. If you specify a scalar value, that setting is replicated over the channel vector. If you specify a value of 1, the corresponding channel is reset to the value specified in the initial

value vector. If you specify a value of - 1, the block sets the channel to the value specified in the **Final value vector** value for that channel. If you specify a value of 0, the channel remains at the last value attained while the model was running.

Final value vector

The final value vector contains the final value for each output channel. Enter a scalar or a vector that is the same length as the channel vector. If you specify a scalar value, that setting is replicated over the channel vector. If the **Final action vector** is - 1, the block sets the channel to this value on model termination.

Double buffering

From the list, select:

- **Disable**

Disable the use of double-buffering for synchronizing multiple IPs.

- **Rising edge**

Enable the use of double-buffering for synchronizing multiple IPs on the rising edge.

- **Falling edge**

Enable the use of double-buffering for synchronizing multiple IPs on the falling edge.

To enable double-buffering, you must have an external clock attached to the board. See the IP-UD-IHV user documentation for details.

Sample time

Enter the base sample time or a multiple of the base sample time (- 1 means sample time is inherited).

External Websites

- www.abaco.com

SBS IP-UD-IHV-8I160

Support for the SBS IP-UD-IHV-8I160 board

Board

SBS IP-UD-IHV-8I160

General Description

The SBS IP-UD-IHV-8I160 board is an IndustryPack board with 8 inputs and 16 outputs. Each IP module must be physically plugged into an IP carrier board such as the PCI-40B. Models containing IP module blocks must also contain corresponding IP carrier blocks. Each carrier block has a unique **Carrier ID** parameter.

The Simulink Real-Time block library supports this board with these driver blocks:

- SBS IP-UD-IHV-8I160 Digital Input
- SBS IP-UD-IHV-8I160 Digital Output

The following table illustrates the mapping between the SBS IP-UD-IHV-8I160 board lines and the Simulink Real-Time block channels.

Note: In this table, columns **Byte** and **Bit** correspond to the **Format** parameter 8-bit and 1-bit channel modes of the SBS IP-UD-IHV-8I160 Digital Input and SBS IP-UD-IHV-8I160 Digital Output blocks.

SBS Lines	Block Channels		Direction I/O
	Byte	Bit	
1	1	1	Input
2		2	Input
3		3	Input
4		4	Input

SBS Lines	Block Channels		Direction I/O
	Byte	Bit	
5		5	Input
6		6	Input
7		7	Input
8		8	Input
9	1	1	Output
10		2	Output
11		3	Output
12		4	Output
13		5	Output
14		6	Output
15		7	Output
16		8	Output
17	2	9	Output
18		10	Output
19		11	Output
20		12	Output
21		13	Output
22		14	Output
23		15	Output
24		16	Output

Board Characteristics

Board name

SBS IP-UD-IHV-8I160

Manufacturer

GE Intelligent Platforms (formerly SBS Technologies)

Bus type

PCI

Multiple block instance support	No
Multiple board support	Yes

External Websites

- www.abaco.com

SBS IP-UD-IHV-8I160 Digital Input

SBS IP-UD-IHV-8I160 Digital Input block

Library

Simulink Real-Time Library for SBS Technologies

Scaling Input to Output

Hardware Input	Block Output Data Type	Scaling
Volts	Double (Format:8 1-bit Channels)	Double: < Threshold = 0.0 > Threshold = 1.0
	uint8 (Format:One 8-bit Channel)	uint32: < Threshold, corresponding bit is clear > Threshold, corresponding bit is set

Block Parameters

Carrier ID

Enter a number to uniquely identify this IP carrier board within the model.

Carrier slot

Select the slot on the carrier board into which the module IP-UD-IHV-8I160 is plugged. Different carrier boards can have different slot capacities. From the list, select A, B, C, or D.

Format

From the list, select one of the following modes:

- 8 1-bit Channels

Configures block to accept up to eight 1-bit channels.

- **One 8-bit Channel**

Configures block to accept one 8-bit channel.

Channel vector

This value depends on the value of **Format**, as follows:

- If you select the **Format** parameter to be **8 1-bit Channels**, enter a vector of numbers between 1 and 8. For example, to use the first and third digital input channels, enter

[1, 3]

- If you select the **Format** parameter to be **One 8-bit Channels**, enter a vector number of 1. For example, to use the single digital input channel, enter

[1]

Note: The manufacturer numbers its lines sequentially from 1 to 24, regardless of the line's function. The input lines of this board are numbered 1 to 8. For Simulink Real-Time blocks, the channel numbers depend on the setting of the **Format** parameter. If you select the **Format** parameter to be **8 1-bit Channels** (bit mode), the channel numbers range from 1 to 8. If you select the **Format** parameter to be **One 8-bit Channels** (byte mode), the channel number is 1. See the mapping table in SBS IP-UD-IHV-8I160.

Threshold

Enter a threshold value. This block reads the input as 1 if the input voltage multiplied by the operational amplifier (op amp) gain is greater than this threshold value. This block reads the input as 0 if the input voltage is less than this threshold value.

The maximum value of **Threshold** is 61.68 volts. It has a granularity of 15 millivolts. See the IP-UD-IHV user documentation for details.

Sample time

Enter the base sample time or a multiple of the base sample time (-1 means sample time is inherited).

External Websites

- www.abaco.com

SBS IP-UD-IHV-8I160 Digital Output

SBS IP-UD-IHV-8I160 Digital Output block

Library

Simulink Real-Time Library for SBS Technologies

Scaling Output to Input

Hardware Input	Block Output Data Type	Scaling
Volts	Double (Format:16 1-bit Channels)	Double: < 0.5, off >0.5, on
	uint8 (Format:Two 8-bit Channels)	uint32: Bit clear, off Bit set, on

Block Parameters

Carrier ID

Enter a number to uniquely identify this IP carrier board within the model.

Carrier slot

Select the slot on the carrier board into which the module IP-UD-IHV-16I80 is plugged. Different carrier boards can have different slot capacities. From the list, select A, B, C, or D.

Format

From the list, select one of the following modes:

- 16 1-bit Channels

Configures block to accept up to 16 1-bit channels.

- Two 8-bit Channels

Configures block to accept two 8-bit channels.

Channel vector

This value depends on the value of **Format**, as follows:

- If you select the **Format** parameter to be **16 1-bit Channels**, enter a vector of numbers between 1 and 16. For example, to use the first and third digital input channels, enter

[1, 3]

- If you select the **Format** parameter to be **Two 8-bit Channels**, enter a vector of numbers between 1 and 2. For example, to use the first and second digital input channels, enter

[1, 2]

Note: The manufacturer numbers its lines sequentially from 1 to 24, regardless of the line's function. The output lines of this board are numbered 9 to 24. For Simulink Real-Time blocks, the channel numbers depend on the setting of the **Format** parameter. If you select the **Format** parameter to be **16 1-bit Channels** (bit mode), the channel numbers range from 1 to 16. If you select the **Format** parameter to be **Two 8-bit Channels** (byte mode), the channel number is 1 to 2. See the mapping table in **SBS IP-UD-IHV-8I160**.

Initial value vector

The initial value vector contains the initial voltage values for the output channels. Enter a scalar or a vector that is the same length as the channel vector. If you specify a scalar value, that value is replicated as the initial value over the channel vector. The channels are set to the initial values between the time the model is downloaded and the time it is started.

Final action vector

The final action vector controls the behavior of the channel at model termination. Enter a scalar or a vector that is the same length as the channel vector. If you specify a scalar value, that setting is replicated over the channel vector. If you specify a value of **1**, the corresponding channel is reset to the value specified in the initial value vector. If you specify a value of **-1**, the block sets the channel to the value

specified in the **Final value vector** value for that channel. If you specify a value of 0, the channel remains at the last value attained while the model was running.

Final value vector

The final value vector contains the final value for each output channel. Enter a scalar or a vector that is the same length as the channel vector. If you specify a scalar value, that setting is replicated over the channel vector. If the **Final action vector** is -1, the block sets the channel to this value on model termination.

Double buffering

From the list, select:

- **Disable**

Disable the use of double-buffering for synchronizing multiple IPs.

- **Rising edge**

Enable the use of double-buffering for synchronizing multiple IPs on the rising edge.

- **Falling edge**

Enable the use of double-buffering for synchronizing multiple IPs on the falling edge.

To enable double-buffering, you must have an external clock attached to the board. See the IP-UD-IHV user documentation for details.

Sample time

Enter the base sample time or a multiple of the base sample time (-1 means sample time is inherited).

External Websites

- www.abaco.com

SBS IP-Unidig-E-48

Support for the SBS IP-Unidig-E-48 board

Board

SBS IP-Unidig-E-48

General Description

IP-Unidig-E-48 boards have 48 digital I/O lines which can be independently configured for input or output.

The Simulink Real-Time block library supports this board with these driver blocks:

- SBS IP-Unidig-E-48 Digital Input
- SBS IP-Unidig-E-48 Digital Output

Board Characteristics

Board name	IP-Unidig-E-48
Manufacturer	GE Intelligent Platforms (formerly SBS Technologies)
Bus type	N/A
Access method	I/O Mapped
Multiple block instance support	Yes
Multiple board support	Yes

External Websites

- www.abaco.com

SBS IP-Unidig-E-48 Digital Input

IP-Unidig-E-48 Digital Input block

Library

Simulink Real-Time Library for SBS Technologies

Scaling Input to Output

Hardware Input	Block Output Data Type	Scaling
TTL	double	TTL low = 0.0 TTL high = 1.0

Block Parameters

Carrier ID

Enter the Carrier ID of the IP carrier board into which the IP module is plugged.

To use an IP module, it must be physically plugged into an IP carrier board and the model must contain a block representing this carrier board. Each carrier block has a **Carrier ID** parameter, which must be set to a number not shared by another carrier board block in the model.

Carrier slot

Select the slot on the carrier board into which the IP-Unidig-E-48 module is plugged. Different carrier boards can have different slot capacities.

Channel vector

Enter numbers between 1 and 48 to select the digital input lines to be used. This driver allows the selection of individual digital input lines in arbitrary order. The number of elements defines the number of lines used.

For example, to use the first three digital inputs, enter

```
[1,2,3]
```

Number the lines beginning with 1 even if this board manufacturer starts numbering the lines with 0.

Sample time

Enter the base sample time or a multiple of the base sample time (- 1 means sample time is inherited).

External Websites

- www.abaco.com

SBS IP-Unidig-E-48 Digital Output

IP-Unidig-E-48 Digital Output block

Library

Simulink Real-Time Library for SBS Technologies

Scaling Input to Output

Hardware Input	Block Output Data Type	Scaling
TTL	double	TTL low = 0.0 TTL high = 1.0

Block Parameters

Carrier ID

Enter the Carrier ID of the IP carrier board into which the IP module is plugged.

To use an IP module, it must be physically plugged into an IP carrier board and the model must contain a block representing this carrier board. Each carrier block has a **Carrier ID** parameter, which must be set to a number not shared by another carrier board block in the model.

Channel vector

Enter numbers between 1 and 48 to select the digital output lines to be used. This driver allows the selection of individual digital output lines in arbitrary order. The number of elements defines the number of lines used.

For example, to use the first three digital outputs, enter

[1,2,3]

Number the lines beginning with 1 even if this board manufacturer starts numbering the lines with 0.

Sample time

Enter the base sample time or a multiple of the base sample time (- 1 means sample time is inherited).

External Websites

- www.abaco.com

SBS PCI-40A Carrier Board

Support for the SBS PCI-40A Carrier board

Board

SBS PCI-40A Carrier Board

General Description

Each IP module must be physically plugged into an IP carrier board such as the PCI-40A. Models containing IP module blocks must also contain corresponding IP carrier blocks. If your model contains multiple carriers, be sure to use a unique ID for each carrier. The relationship “IP module A is plugged into carrier B” is expressed by selecting the same Carrier ID for both A and B. The PCI-40A holds up to four IP modules. The Simulink Real-Time block library supports this board with this driver block:

- SBS PCI - 40A

Board Characteristics

Board name	PCI-40A carrier board
Manufacturer	GE Intelligent Platforms (formerly SBS Technologies)
Bus type	PCI
Access method	I/O Mapped
Multiple block instance support	No
Multiple board support	Yes

External Websites

- www.abaco.com

SBS PCI-40A

PCI-40A block

Library

Simulink Real-Time Library for SBS Technologies

Block Parameters

Carrier ID

Enter a number to uniquely identify this IP carrier board within the model. If your model contains multiple carriers, be sure to use a unique ID for each carrier.

PCI slot (-1:autosearch)

If only one board of this type is in the target computer, enter - 1 to locate the board.

If two or more boards of this type are in the target computer, enter the bus number and the PCI slot number of the board associated with this driver block. Use the format **[BusNumber,SlotNumber]**.

To determine the bus number and the PCI slot number, type:

```
tg = slrt;  
getPCIInfo(tg, 'installed')
```

External Websites

- www.abaco.com

SBS PCI-40B Carrier Board

Support for the SBS PCI-40B Carrier board

Board

SBS PCI-40B Carrier Board

General Description

Each IP module must be physically plugged into an IP carrier board such as the PCI-40B. Models containing IP module blocks must also contain corresponding IP carrier blocks. If your model contains multiple carriers, be sure to use a unique ID for each carrier. The relationship “IP module A is plugged into carrier B” is expressed by selecting the same carrier ID for both A and B. The PCI-40B holds up to four IP modules. The Simulink Real-Time block library supports this board with this driver block:

- SBS PCI - 40B

Board Characteristics

Board name	PCI-40B carrier board
Manufacturer	GE Intelligent Platforms (formerly SBS Technologies)
Bus type	PCI
Multiple block instance support	No
Multiple board support	Yes

External Websites

- www.abaco.com

SBS PCI-40B

PCI-40B block

Library

Simulink Real-Time Library for SBS Technologies

Block Parameters

Carrier ID

Enter a number to uniquely identify this IP carrier board within the model. If your model contains multiple carriers, be sure to use a unique ID for each carrier.

PCI slot (-1:autosearch)

If only one board of this type is in the target computer, enter - 1 to locate the board.

If two or more boards of this type are in the target computer, enter the bus number and the PCI slot number of the board associated with this driver block. Use the format [**BusNumber**, **SlotNumber**].

To determine the bus number and the PCI slot number, type:

```
tg = slrt;  
getPCIInfo(tg, 'installed')
```

External Websites

- www.abaco.com

General Standards, HUMUSOFT

General Standards

This topic describes General Standards I/O boards supported by the Simulink Real-Time product (www.generalstandards.com).

- “PMC-ADADIO Basics” on page 38-2
- “Adding A/D Blocks for Analog Input” on page 38-4
- “Adding Enable Signal Blocks for Input Enable” on page 38-6
- “Adding D/A Blocks for Analog Output” on page 38-8
- “Interleaving Analog Input and Output Blocks” on page 38-10
- “Using Multiple PMC-ADADIO Boards” on page 38-12
- “Overview of Audio Systems” on page 38-14

PMC-ADADIO Basics

The PMC-ADADIO board is an analog I/O PCI mezzanine card (PMC) device that can be used, for example, for data acquisition and process monitoring.

The Simulink Real-Time block library supports this board with A/D and D/A driver blocks. The following Simulink Real-Time driver blocks control the A/D functionality of the PMC-ADADIO board:

- General Standards PMC-ADADIO Analog Input (A/D) Start
- General Standards PMC-ADADIO Analog Input (A/D) Read

The following Simulink Real-Time driver blocks control the D/A functionality of the PMC-ADADIO board:

- General Standards PMC-ADADIO Analog Output Write Block
- General Standards PMC-ADADIO Analog Output (D/A) Update

The use of these drivers differ slightly from other boards. Of particular note are the Boolean enable ports (labelled E) that most of the A/D and D/A blocks have for input and/or output. These enable ports perform the following:

- Control block action. If the value of the input enable port is true, the block executes. If the value is false, the block does not execute. Most blocks also have output enable ports. The output enable port has the same value as the input enable port. This allows the control block action value to be passed to successive blocks.
- Specifies the order in which A/D and D/A blocks execute. For example, the **A/D Start** block starts the analog to digital conversion of the channels selected by the **A/D Read** block. This block must finish its operation before the **A/D Read** block can execute. If the **A/D Read** block executes first, the **A/D Read** block waits indefinitely for the A/D conversion to complete.

An input enable port can have an **Enable Signal** block connected to the port. The **Enable Signal** block generates an input enable signal for the A/D and D/A blocks. If you do not connect an **Enable Signal** block to the A/D or D/A block, the input enable port has a constant value of 1, or **true**.

A typical A/D block configuration for analog input operation connects the **AD Start** block and **AD Read** block. Because the **A/D Start** block can take several microseconds to perform the analog to digital conversion of the channels selected by the **A/D Read**

block, you can perform other operations in the meantime. For example, you can insert a typical D/A block configuration between the `AD Start` and `AD Read` blocks. A typical configuration for analog output operation connects the `DA Write` and `DA Update` blocks.

Adding A/D Blocks for Analog Input

A typical A/D block configuration for analog input operation connects the AD Start block and AD Read block. The AD Start block converts the data of the channels selected by the AD Read block.

- 1 In the MATLAB Command Window, type

```
slrplib
```

The Simulink Real-Time driver block library opens.

- 2 Double-click the A/D group block.

A window with blocks for A/D drivers opens.

- 3 Double-click the General Standards group block.

A window with blocks for General Standards opens.

- 4 From the File menu, click **New > Model**.

- 5 Drag an AD Start block from the General Standards window to the new model.

By default, this block should have the **Enable input port** and **Enable output port** check boxes selected.

- 6 Drag an AD Read block from the General Standards window to the new model.

By default, this block has the **Enable input port** and **Enable output port** check boxes selected. Double-click the AD Read block and clear the **Enable output port** check box. Clearing this check box prohibits the block from passing the Boolean value from the input enable port to the output enable port.

- 7 Connect the AD Start block to the AD Read block.

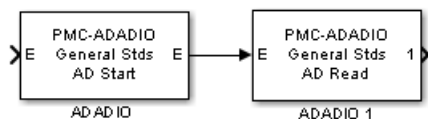

Note the following:

- A signal has not been connected to the AD Start block's input enable port, E, so the port has a default value of `true`. Accordingly, the output enable port of the

AD Start block and input enable port of the AD Read block also have a value of `true`.

Tip

- Drag a Ground block from the Simulink Source library to your model. Connect that block to the unconnected input port of AD Start to prevent build errors until you add another block.
 - Drag a Terminator block from the Simulink Sink library to your model. Connect that block to the unconnected output ports of AD Read to prevent build errors until you add another block.
-
- Connecting the output enable port of the AD Start block to the input enable port of the AD Read block causes the AD Start block to execute before the AD Read block. The AD Start block initiates the A/D conversion. The Read block waits until the conversion has completed before putting the results on its output port.

Note: The Start block must execute before every call to the Read block. If the Read block is executed without the Start block, the system hangs because it is waiting for data to be available.

- 8** From the File menu, select **Save As**. Browse to a writable folder and enter a unique model name, for example, **AdadioADDA**. Then click **Save**.

Your next task is to add a Create Enable Signal block to this model. See “Adding Enable Signal Blocks for Input Enable” on page 38-6.

Adding Enable Signal Blocks for Input Enable

The A/D and D/A series of blocks both have Create Enable Signal blocks. You can use these blocks to generate an input enable signal for A/D and D/A blocks. You can connect a signal generator to the input of the Create Enable Signal block to control the output enable port. You can then connect the output E port of the Create Enable Signal block to the input E port of an A/D or D/A block.

This procedure assumes that you have a model named AdadioADDA (see “Adding A/D Blocks for Analog Input” on page 38-4). Add a Create Enable Signal block to generate an input enable signal for the AD Start block. If you have Ground or Terminator blocks, remove them as you make connections to the additional blocks.

- 1 If your model AdadioADDA is not already open, in the MATLAB Command Window, type

```
AdadioADDA
```

The model opens.

- 2 In the MATLAB window, type

```
slrplib
```

The Simulink Real-Time library opens.

- 3 Double-click the A/D group block.

A window with blocks for A/D drivers opens.

- 4 Double-click the General Standards group block.

A window with blocks for General Standards opens.

- 5 Drag a Create Enable Signal block from the General Standards window to the new model.

- 6 Double click the Create Enable Signal block and deselect the Show input port for thresholding signal of type double.

The Create Enable block has an output enable port, E, that can provide an input enable signal for the other PMC-ADADIO blocks. The Boolean value of this output enable port is controlled by an input port, S, and (optionally) an input port, L. When the S port is connected to the output of an arbitrary block B, the Create Enable Signal block executes immediately after block B executes. The L port is a level-

sensitive thresholding port that allows an attached signal to control the Boolean value at the output enable port E.

- 7 In the Simulink dialog box, click **View > Library Browser**.
- 8 Click node **Sources**. The Sources pane displays the included blocks.
- 9 Drag a Sine Wave block to the new model.
- 10 Connect the output port of the Sine Wave block to the input port S of the Create Enable Signal block.

Connecting the Sine Wave to the Create Enable Signal block triggers the sequence chain of the ADADIO blocks.

- 11 In the new model, connect the S port of the Create Enable Signal block to the Sine Wave block.
- 12 In the new model, connect the AD Start block E port to the Create Enable Signal E port.

The output enable port, E, of the Create Enable Signal block provides the first Boolean output to feed into the other ADADIO driver blocks.

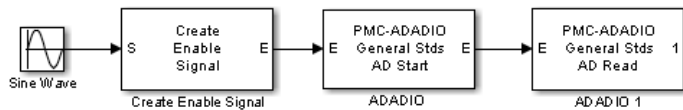

- 13 From the File menu, select **Save**.

Your next task is to set up the D/A blocks to provide the analog output for the analog input blocks.

Adding D/A Blocks for Analog Output

A typical D/A block configuration for analog output operation connects the DA Write block and DA Update block. The DA Update block converts the data that the DA Write block puts out.

- 1 If the model AdadioADDA is not already open, in the MATLAB Command Window, type

```
AdadioADDA
```

The model opens.

- 2 In the MATLAB window, type

```
slrplib
```

The Simulink Real-Time library opens.

- 3 Double-click the D/A group block.

A window with blocks for D/A drivers opens.

- 4 Double-click the General Standards group block.

A window with blocks for General Standards opens.

- 5 Drag a DA Write block from the General Standards window to the new model.
- 6 Drag a DA Update block from the General Standards window to the new model.
- 7 Connect the DA Write block to the DA Update block.

The model looks like this figure.

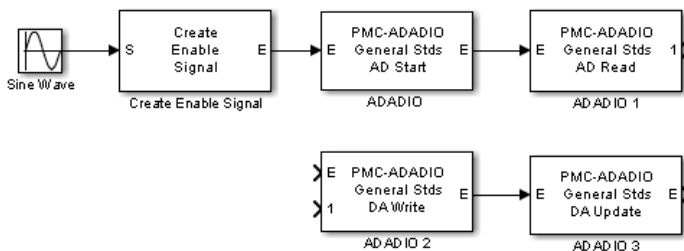

Note the following:

- A signal has not been connected to the DA Write block's input enable port, E, so the port has a default value of 'true'. Accordingly, the output enable port of the DA Write block and input enable port of the DA Update block also have a value of 'true'.
- Connecting the output enable port of the DA Write block to the input enable port of the DA Update block causes the DA Write block to execute before the DA Update block. The DA Write block loads the PMC-ADADIO registers in preparation for the D/A conversion. The DA Update block waits until the loading has completed before initiating the D/A conversion. As with the AD Start and AD Read blocks, the DA Write and DA Update blocks do not need to be directly connected to each other. You can interleave other blocks if you want.

You can interleave the analog output blocks between the AD Start and AD Read blocks. Such a configuration allows the analog output block to perform concurrently with the A/D conversion by the AD Start block. To connect to the AD Start and AD Read blocks, the interleaving block(s) must have an input enable port and an output enable port. See “Interleaving Analog Input and Output Blocks” on page 38-10.

Interleaving Analog Input and Output Blocks

After the `AD Start` block executes, the acquisition I/O module becomes busy with the operation. If you configure the `AD Read` block to execute immediately, it sits idle waiting for the module to finish the acquisition. Rather than allowing idle cycles, you can insert other blocks between the `AD Start` and `AD Read` block

- An atomic subsystem that has a pass through input for the enable signal from the `AD Start` to the `AD Read` blocks. This type of system enforces an execution order where the inserted subsystem executes between the other two blocks.
- A pair of blocks that already have an enable port, such as `DA Write` and `DA Update`. Because the `DA Write` and `DA Update` blocks already have an enable port, you do not have to include them in another subsystem to specify their order of execution. See the following enable line for the execution order:
 - a `AD Start` enable out to `DA Write` enable in
 - b `DA Write` enable out to `DA Update` enable in
 - c `DA Update` enable out to `AD Read` enable in

This results in the time sequence `AD Start`⇒`DA Write`⇒`DA Update`⇒`AD Read`. By the time `AD Read` executes, the I/O module has either finished or is much closer to finishing. Less time is wasted than if you do not use interleaving. Note that the data input to `DA Write` comes from another part of the model. Typically, it will be the value calculated from the `AD Read` from the previous time step.

The following procedure assumes that you have a model named `AdadioADDA` that has `AD Start` and `AD Read` blocks, an `Enable Create Signal` block, a `DA Write` and a `DA Update` blocks:

- 1 If the model `AdadioADDA` is not already open, in the MATLAB Command Window, type

```
AdadioADDA
```

The model opens.

- 2 In the MATLAB window, type

```
slrplib
```

The Simulink Real-Time library opens.

- 3 Disconnect the AD Start block from the AD Read block.

Perform this step to insert the intermediate DA blocks between the AD Start and AD Read blocks.

- 4 Connect the output E port of the AD Start block to the input E port of the DA Write block.
- 5 Connect the output port of the Sine Wave block to the input 1 port of the DA Write block.
- 6 Connect the output E port of the DA Write block to the input E port of the DA Update block.
- 7 Connect the output E port of the DA Update block to the input E port of the AD Read block.
- 8 At the Simulink Real-Time library, double-click the Displays and Logging group block
- 9 Drag the real-time Scope block to the AdadioADDA model.
- 10 Connect the output E port of the AD Read block to the real-time Scope block.

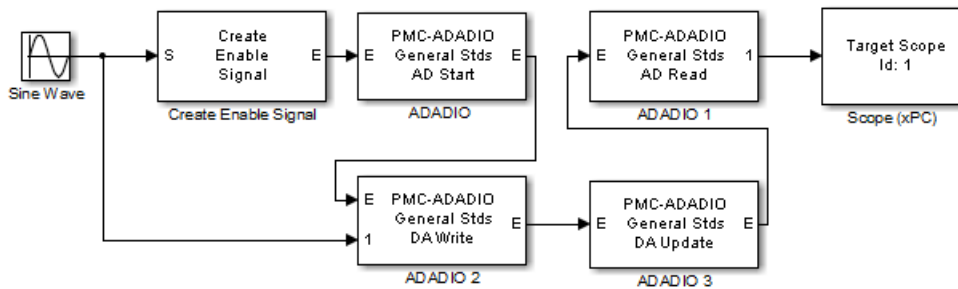

- 11 From the File menu, select **Save**.

You can build and run the model and download it to your target computer like other Simulink Real-Time models.

Using Multiple PMC-ADADIO Boards

The previous topics describe how to set up a model for up to eight channels performing simultaneous analog to digital conversion. You can increase the number of channels for this conversion by using two or more PMC-ADADIO boards, configured in a master/slave configuration.

In such a configuration, observe the following guidelines:

- Decide how many slave PMC-ADADIO boards you want in your configuration.
- Identify one PMC-ADADIO as the master board.
- Create a model that uses the master PMC-ADADIO board. This model must contain an A/D Start block for the master board.
- For each PMC-ADADIO board in your system, including the master and slave boards, the model must contain an associated A/D Read block.
- Connect the Enable output port (E) of the A/D Start block of the master board to the Enable input port (E) of each of the slave A/D Read blocks. You can do this in one of the following ways. Note that the order in which the A/D Read blocks are connected is irrelevant.
 - Directly connect the Enable output port (E) of the A/D Start block to the Enable input port (E) of each of the slave A/D Read blocks.
 - Directly connect the Enable output port (E) of the A/D Start block to the Enable input port (E) of the first slave A/D Read block, then create a daisy chain of slave Enable input to Enable output ports for the slave A/D Read blocks. For example

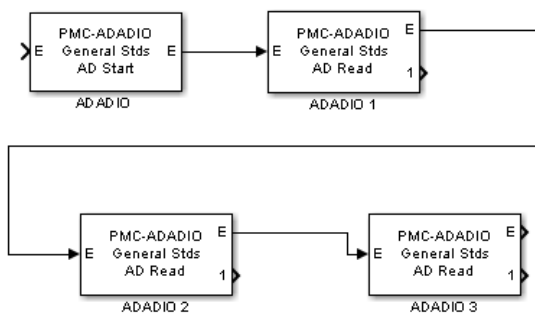

- Connect pin4 of the P5B connector (INPUT TRIGGER READY signal) of the master board to pin 2 of the P5B connector (INPUT TRIGGER signal) of each slave board. For example

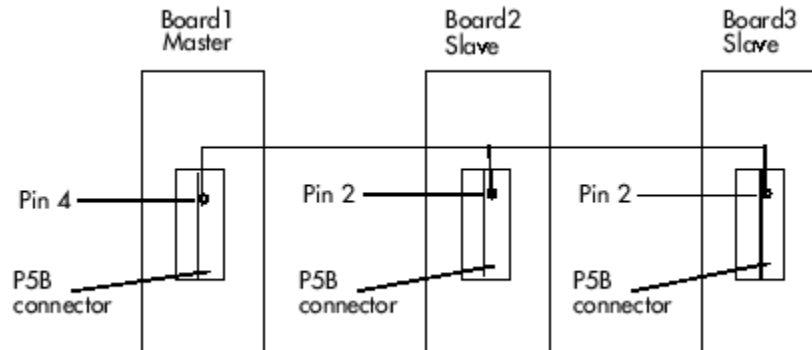

Note: The pulse of the master board INPUT TRIGGER READY output occurs 250 nanoseconds after the software trigger in the A/D Start block. This results in a 250 nanosecond delay, relative to the master board, for the slave boards, but should still be considered simultaneous in most situations.

Overview of Audio Systems

The Simulink Real-Time product supports audio systems with the General Standards PMC-24DSI12 and General Standards PMC66-16A016 boards. The PMC-24DSI12 board provides frame audio input and the PMC66-16A01 board supplies frame audio output. The following Simulink Real-Time blocks support these blocks:

General Standards 24DSI12 Analog Input

Your audio system can include one or more General Standards PMC-24DSI12 boards. If you use multiple boards, designate one as the master. Then, daisy chain the other PMC-24DSI12 board as slaves to this board (see the manufacturer documentation for details).

General Standards 16A016 Analog Output

For audio output, connect the clock output pins from the General Standards PMC-24DSI12 board to the clock input pins of the General Standards PMC66-16A016 board.

Tip

- Connect the boards with two wires twisted along their length.
 - If you are using more than one board, connect the clock output pins from the last board of the chain. See the manufacturer documentation for details.
-

The PMC-24DSI12 clock signal is a high-frequency signal, which requires you to preserve signal integrity when using this board. This signal is a differential signal. When the PMC66-16A016 board receives the input clock signal from the PMC-24DSI12 board, the PMC66-16A016 board divides that clock signal down to the sample rate. When using low voltage differential signaling (LVDS), you cannot slow down the clock for the PMC-24DSI12 board.

General Standards Blocks

This topic describes General Standards I/O blocks supported by the Simulink Real-Time product (www.generalstandards.com).

General Standards PMC-ADADIO

Support for PMC-ADADIO multifunction ADC/DAC board

Board

General Standards PMC-ADADIO

General Description

The PMC-ADADIO is a high speed multifunction board that has eight 16 bit analog to digital converters and four 16 bit digital to analog outputs. Up to eight input channels are sampled simultaneously from a single acquisition start. The board also has 8 bits of TTL level digital I/O. All 8 bits are either inputs or outputs.

You can purchase the PMC-ADADIO board in either a memory mapped or an I/O mapped configuration. The driver detects this configuration and adjusts for it. In addition, you order the board for a specific factory configured voltage range. Consult the manufacturer documentation to determine the voltage range of your board.

The Simulink Real-Time block library supports this board with these driver blocks:

- General Standards Create Enable Signal
- General Standards PMC-ADADIO Analog Input (A/D) Start
- General Standards PMC-ADADIO Analog Input (A/D) Read
- General Standards PMC-ADADIO Analog Output Write Block
- General Standards PMC-ADADIO Analog Output (D/A) Update
- General Standards PMC-ADADIO Digital Input
- General Standards PMC-ADADIO Digital Output

Note that you cannot use the PMC-ADADIO Digital Input and Digital Output driver blocks simultaneously on the same board. Trying to do so results in an error.

Board Characteristics

Board name

PMC-ADADIO

Manufacturer	General Standards
Bus type	PCI
Access method	Memory mapped or I/O mapped
Multiple block instance support	No
Multiple board support	Yes

External Websites

- www.generalstandards.com

General Standards Create Enable Signal

Create Enable Signal block

Library

Simulink Real-Time Library for General Standards

Description

Use the Create Enable Signal block to determine whether a series of blocks executes as well as to start the sequence of the blocks' execution. For example, connect another block in your model to the input port S to trigger the sequence chain of the ADADIO blocks. The output enable port, E, provides the first Boolean output to feed into the other ADADIO driver blocks.

Scaling Input to Output

The values passed to the enable output port of this block are Boolean values.

Block Parameters

Show input port for thresholding signal of type double

Select this check box to display the level input port, L. Connect the signal whose level you want to compare to the threshold value to this port.

If this check box is not selected, then the output enable port has a Boolean value of true. The output enable port provides a link for sequencing the execution of your blocks.

Enable threshold

Enter a threshold value. If the block input signal connected to the level input port, L, is above this threshold, the output enable port has a Boolean value of true. If the input signal is below this threshold, the output enable port has a Boolean value of false.

External Websites

- www.generalstandards.com

General Standards PMC-ADADIO Analog Input (A/D) Start

PMC-ADADIO Analog Input Start block

Library

Simulink Real-Time Library for General Standards

Scaling Input to Output

The values passed to the enable input port and enable output port of this block are Boolean values.

Block Parameters

Enable input port

Select this check box to display the enable input port that controls the execution of the A/D conversion. If the enable input signal is true, the A/D conversion begins. If the enable input signal is false, then the A/D conversion is not started. If this check box is not selected, then the enable input signal is assumed to be true.

Enable output port

Select this check box to pass the Boolean value from the input enable port to the output enable port. You can connect this port to the input enable port on another block to control other blocks in the model and specify execution ordering.

Sample time

Enter the base sample time or a multiple of the base sample time (- 1 means sample time is inherited).

PCI slot (-1:autosearch)

If only one board of this type is in the target computer, enter - 1 to locate the board.

If two or more boards of this type are in the target computer, enter the bus number and the PCI slot number of the board associated with this driver block. Use the format [**BusNumber**, **SlotNumber**].

To determine the bus number and the PCI slot number, type:

```
tg = slrt;  
getPCIInfo(tg, 'installed')
```

External Websites

- www.generalstandards.com

General Standards PMC-ADADIO Analog Input (A/D) Read

PMC-ADADIO Analog Input Read block

Library

Simulink Real-Time Library for General Standards

Scaling Input to Output

I/O Module Input	Block Output Data Type	Scaling
Volts	Double	1

Note

The values passed to the enable input port and enable output port of this block are Boolean values.

Block Parameters

Number of channels

Enter a scalar between 1 and 8 to select the number of channels from which to acquire data. This board acquires data from the channels in numerical order. It is not possible to access channels in a different order or with gaps in the channel sequence.

For example, if you enter 3, data is acquired from channels 1, 2, and 3. Select a number between 1 and 8 even if this manufacturer numbers the channels from 0 to 7.

Range option

From the list, select $+10V$, $+5V$ or $+2.5V$ as the input voltage range of the board. You must select the range that corresponds to the factory configured input range. Consult the manufacturer documentation to determine the voltage range of your

board. The Simulink Real-Time software uses this parameter to convert the data to floating point numbers.

Input coupling

From the list, select **Single-ended (8 channels)** or **Differential (8 channels)**. See the manufacturer documentation for information on how to wire the board for these configurations.

Autocalibration

The PMC-ADADIO can check its own calibration (autocalibration) against an internal voltage reference. Choose this check box to execute the autocalibration cycle when the model is downloaded to the target computer. The output ports show a square wave during the cycle. Unless you subject this board to harsh conditions, you should only need to run autocalibration occasionally—for example, once a month.

Note: The calibration cycle takes several seconds to run. Refer to the manufacturer documentation for further information on autocalibration.

Enable input port

Select this check box to display an input port that controls writing data from the A/D ports on the I/O module. If the enable input signal is true, then the output of the A/D converter is read and output to the block output port. If the enable input signal is false, then zero data is output to the block output port. If this check box is not selected, then the enable input signal is assumed to be true.

Enable output port

Select this check box to pass the Boolean value from the input enable port to the output enable port. You can connect this port to the input enable port on another block to control other blocks in the model and specify execution ordering.

Sample time

Enter the base sample time or a multiple of the base sample time (-1 means sample time is inherited).

PCI slot (-1:autosearch)

If only one board of this type is in the target computer, enter -1 to locate the board.

If two or more boards of this type are in the target computer, enter the bus number and the PCI slot number of the board associated with this driver block. Use the format **[BusNumber, SlotNumber]**.

To determine the bus number and the PCI slot number, type:

```
tg = slrt;  
getPCIInfo(tg, 'installed')
```

External Websites

- www.generalstandards.com

General Standards PMC-ADADIO Analog Output Write Block

PMC-ADADIO Analog Output Write block

Library

Simulink Real-Time Library for General Standards

Note

Data from 1 to 4 input data streams is written to the digital to analog output registers when the enable port also receives a true value. If the enable port is not used, then it is assumed to be set to true. The output registers are held and not written through to the output converters until the analog output update block is executed.

Scaling Input to Output

I/O Module Output	Block Input Data Type	Scaling
Volts	Double	1

The values passed to the enable input port and enable output port of this block are Boolean values.

Block Parameters

Channel vector

Enter a vector of numbers between 1 and 4 to select the analog output lines to drive. Number the lines beginning with 1 even if this board manufacturer starts numbering the lines with 0.

Reset vector

The reset vector controls the behavior of the channel at model termination. Enter a scalar or a vector that is the same length as the channel vector. If you specify a scalar value, that setting is replicated over the channel vector. If you specify a value of 1, the corresponding channel is reset to the value specified in the initial value vector. If you specify a value of 0, the channel remains at the last value attained while the model was running. For example, if **Channel vector** is [2 3] and the **Reset vector** is [1], the action taken will be the same as if **Reset vector** was set to [1 1]. Both channels will be reset to their initial values when model execution is stopped.

Initial value vector

The initial value vector contains the initial voltage values for the output channels. Enter a scalar or a vector that is the same length as the channel vector. If you specify a scalar value, that value is replicated as initial value over the channel vector. The channels are set to the initial values between the time the model is downloaded and the time it is started. When model execution is stopped, the corresponding position in **Reset vector** is checked. Depending on that value, the channel is either reset to the initial value or remains at the last value attained while the model was running. For example, assume that **Channel vector** is [2 5 8], **Reset vector** is [1 0 1], and **Initial value vector** is [2.3 5.6 0]. On initial download, channel 2 is set to 2.3 volts, channel 5 to 5.6 volts, and channel 8 to 0.0 volts. When the model is stopped, channel 2 resets to 2.3 volts, channel 5 remains at the last value attained, and channel 8 resets to 0.0 volts.

Range vector

From the list, select $\pm 10V$, $\pm 5V$ or $\pm 2.5V$ as the output voltage range of the board. You must select the range that corresponds to the factory configured output range. Consult the manufacturer documentation to determine the voltage range of your board. The Simulink Real-Time software uses this parameter to convert the data from floating point numbers to integers.

Autocalibration

The PMC-ADADIO can check its own calibration (autocalibration) against an internal voltage reference. Choose this check box to execute the autocalibration cycle when the model is downloaded to the target computer. The output ports show a square wave during the cycle. Unless you subject this board to harsh conditions, you should only need to run autocalibration occasionally— for example, once a month.

Note: The calibration cycle takes several seconds to run. Refer to the manufacturer documentation for further information on autocalibration.

Enable input port

Select this check box to display an input enable port that controls writing data to the D/A ports on the I/O module. If the enable input signal is true, then the block input data is written to the D/A ports. If the enable input signal is false, then data is not written to the D/A ports and the output remains at the previous value. If this check box is not selected, then the enable input signal is assumed to be true.

Enable output port

Select this check box to pass the Boolean value from the input enable port to the output enable port. You can connect this port to the input enable port on another block to control other blocks in the model and specify execution ordering.

Sample time

Enter the base sample time or a multiple of the base sample time (- 1 means sample time is inherited).

PCI slot (-1:autosearch)

If only one board of this type is in the target computer, enter - 1 to locate the board.

If two or more boards of this type are in the target computer, enter the bus number and the PCI slot number of the board associated with this driver block. Use the format [**BusNumber,SlotNumber**].

To determine the bus number and the PCI slot number, type:

```
tg = slrt;  
getPCIInfo(tg, 'installed')
```

External Websites

- www.generalstandards.com

General Standards PMC-ADADIO Analog Output (D/A) Update

PMC-ADADIO Analog Output Update block

Library

Simulink Real-Time Library for General Standards

Scaling Input to Output

The values passed to the enable input port and enable output port of this block are Boolean values.

Block Parameters

Enable input port

Select this check box to display an input enable port that controls writing data to the D/A ports on the I/O module. If the enable input signal is true, then the block input data is written to the D/A ports. If the enable input signal is false, then data is not written to the D/A ports and the output remains at the previous value. If this check box is not selected, then the enable input signal is assumed to be true.

Enable output port

Select this check box to pass the Boolean value from the input enable port to the output enable port. You can connect this port to the input enable port on another block to control other blocks in the model and specify execution ordering.

Sample time

Enter the base sample time or a multiple of the base sample time (- 1 means sample time is inherited).

PCI slot (-1:autosearch)

If only one board of this type is in the target computer, enter - 1 to locate the board.

If two or more boards of this type are in the target computer, enter the bus number and the PCI slot number of the board associated with this driver block. Use the format **[BusNumber,SlotNumber]**.

To determine the bus number and the PCI slot number, type:

```
tg = slrt;  
getPCIInfo(tg, 'installed')
```

External Websites

- www.generalstandards.com

General Standards PMC-ADADIO Digital Input

PMC-ADADIO Digital Input block

Library

Simulink Real-Time Library for General Standards

Note

Note that you cannot use the PMC-ADADIO Digital Input and Digital Output driver blocks simultaneously on the same board. Doing so causes an error at model update or build.

Scaling Input to Output

I/O Module Input	Block Output Data Type	Scaling
TTL	Double	TTL low = 0.0 TTL high = 1.0

The values passed to the enable input port and enable output port of this block are Boolean values.

Block Parameters

Channel vector

Enter numbers between 1 and 8 to select the digital input lines to be read. This driver allows the selection of individual digital input lines in arbitrary order. The number of elements defines the number of digital lines used.

For example, to use all of the digital inputs, enter

```
[1,2,3,4,5,6,7,8]
```

Number the lines beginning with 1 even if this board manufacturer starts numbering the lines with 0. Note that the 8 digital lines are either all input or all output.

Enable input port

Select this check box to display an input enable port that controls writing data from the digital input ports on the I/O module. If the enable input signal is true, then the digital input values are read and output to the block output port. If the enable input signal is false, then zero data is output to the block output port. If this check box is not selected, then the enable input signal is assumed to be true.

Enable output port

Select this check box to pass the Boolean value from the input enable port to the output enable port. You can connect this port to the input enable port on another block to control other blocks in the model and specify execution ordering.

Sample time

Enter the base sample time or a multiple of the base sample time (- 1 means sample time is inherited).

PCI slot (-1:autosearch)

If only one board of this type is in the target computer, enter - 1 to locate the board.

If two or more boards of this type are in the target computer, enter the bus number and the PCI slot number of the board associated with this driver block. Use the format [**BusNumber,SlotNumber**].

To determine the bus number and the PCI slot number, type:

```
tg = slrt;  
getPCIInfo(tg, 'installed')
```

External Websites

- www.generalstandards.com

General Standards PMC-ADADIO Digital Output

PMC-ADADIO Digital Output block

Library

Simulink Real-Time Library for General Standards

Note

Note that you cannot use the PMC-ADADIO Digital Input and Digital Output driver blocks simultaneously on the same board. Doing so causes an error at model update or build.

Scaling Input to Output

I/O Module Output	Block Input Data Type	Scaling
TTL	Double	< 0.5 = TTL low ≥ 0.5 = TTL high

The values passed to the enable input port and enable output port of this block are Boolean values.

Block Parameters

Channel vector

Enter numbers between 1 and 8 to select the digital output lines to be written. This driver allows the selection of individual digital output lines in arbitrary order. The number of elements defines the number of digital lines used.

For example, to use all of the digital outputs, enter

[1, 2, 3, 4, 5, 6, 7, 8]

Number the lines beginning with 1 even if this board manufacturer starts numbering the lines with 0. Note that the 8 digital lines are either all input or all output.

Reset vector

The reset vector controls the behavior of the channel at model termination. Enter a scalar or a vector that is the same length as the channel vector. If you specify a scalar value, that setting is replicated over the channel vector. If you specify a value of 1, the corresponding channel is reset to the value specified in the initial value vector. If you specify a value of 0, the channel remains at the last value attained while the model was running. For example, if **Channel vector** is [2 3] and the **Reset vector** is [1], the action taken will be the same as if **Reset vector** was set to [1 1]. Both channels will be reset to their initial values when model execution is stopped.

Initial value vector

The initial value vector contains the initial logical values for the output channels. Enter a scalar or a vector that is the same length as the channel vector. These values can only contain 1's and 0's. If you specify a scalar value, that value is replicated as initial value over the channel vector. The channels are set to the initial values between the time the model is downloaded and the time it is started. When model execution is stopped, the corresponding position in **Reset vector** is checked. Depending on that value, the channel is either reset to the initial value or remains at the last value attained while the model was running. For example, assume that **Channel vector** is [2 5 8], **Reset vector** is [1 0 1], and **Initial value vector** is [1 1 0]. On initial download, channel 2 is set to high, channel 5 to high, and channel 8 to low. When the model is stopped, channel 2 resets to high, channel 5 remains at the last value attained, and channel 8 resets to low.

Enable input port

Select this check box to display an input enable port that controls writing data to the digital output ports on the I/O module. If the enable input signal is true, then the block input data is written to the digital output ports. If the enable input signal is false, then data is not written to the digital output ports and the output remains at the previous value. If this check box is not selected, then the enable input signal is assumed to be true.

Enable output port

Select this check box to pass the Boolean value from the input enable port to the output enable port. You can connect this port to the input enable port on another block to control other blocks in the model and specify execution ordering.

Sample time

Enter the base sample time or a multiple of the base sample time (- 1 means sample time is inherited).

PCI slot (-1:autosearch)

If only one board of this type is in the target computer, enter - 1 to locate the board.

If two or more boards of this type are in the target computer, enter the bus number and the PCI slot number of the board associated with this driver block. Use the format [**BusNumber**,**SlotNumber**].

To determine the bus number and the PCI slot number, type:

```
tg = slrt;  
getPCIInfo(tg, 'installed')
```

External Websites

- www.generalstandards.com

General Standards PMC-16AO-12

Support for the GS PMC-16AO-12 high-speed analog board.

Board

General Standards PMC-16AO-12

General Description

The PMC-16AO12 board is a high speed board that has twelve 16-bit analog outputs. In this section, PMC-16AO12 refers to the board, PMC-16AO-12 refers to the Simulink Real-Time block.

The Simulink Real-Time block library supports this board with these driver blocks:

- General Standards PMC-16AO-12 Analog Output

Board Characteristics

Board name	PMC-16AO12
Manufacturer	General Standards
Bus type	PCI
Access method	Memory mapped
Multiple block instance support	No
Multiple board support	Yes

External Websites

- www.generalstandards.com

General Standards PMC-16AO-12 Analog Output

PMC-16AO-12 Analog Output block

Library

Simulink Real-Time Library for General Standards

Scaling Input to Output

The analog output range of this board depends on the output range that was chosen at the time of purchase. This range can be $+2.5$, $+5.0$, or $+10.0$.

I/O Module Output	Block Input Data Type	Scaling
Volts	Double	1

Block Parameters

Channel vector

Enter numbers between 1 and 12. This is a vector parameter that specifies the output channels. For example, to produce output on channels 2 and 3, enter

[2 3]

The unspecified channels are set to 0.0 volts on output.

Number the channels beginning with 1 although the board manufacturer starts numbering the channels with 0.

Reset vector

The reset vector controls the behavior of the channel at model termination. Enter a scalar or a vector that is the same length as the channel vector. If you specify a scalar value, that setting is replicated over the channel vector. If you specify a value of 1, the corresponding channel is reset to the value specified in the initial value vector. If you specify a value of 0, the channel remains at the last value attained while the model was running. For example, if **Channel vector** is [2 3] and the

Reset vector is [1], the action taken will be the same as if **Reset vector** was set to [1 1]. Both channels will be reset to their initial values when model execution is stopped.

Initial value vector

The initial value vector contains the initial voltage values for the output channels. Enter a scalar or a vector that is the same length as the channel vector. If you specify a scalar value, that value is replicated as initial value over the channel vector. The channels are set to the initial values between the time the model is downloaded and the time it is started. When model execution is stopped, the corresponding position in **Reset vector** is checked. Depending on that value, the channel is either reset to the initial value or remains at the last value attained while the model was running. For example, assume that **Channel vector** is [2 5 8], **Reset vector** is [1 0 1], and **Initial value vector** is [2.3 5.6 0]. On initial download, channel 2 is set to 2.3 volts, channel 5 to 5.6 volts, and channel 8 to 0.0 volts. When the model is stopped, channel 2 resets to 2.3 volts, channel 5 remains at the last value attained, and channel 8 resets to 0.0 volts.

Range

From the list, choose either + - 2.5, + - 5.0, or + - 10.0. The PMC-16AO-12 is specified at purchase time as having one of these three ranges. Choose the range to match that for which the board is configured.

Note that the range you set does not alter the configuration on the board. It is used to scale the signal when it is converted to a 16-bit value to be written to the output D/A converter (DAC).

Autocalibration

The PMC-16AO-12 can check its own calibration (autocalibration) against an internal voltage reference. Choose this check box to execute the autocalibration cycle when the model is downloaded to the target computer. The output ports show a square wave during the cycle. The calibration cycle yields adjustment factors that are retained in onboard NVRAM. The PMC-16AO-12 reads these adjustment factors when the board is initialized. Unless you subject this board to harsh conditions, you should only need to run autocalibration occasionally—for example, once a month.

Note: The calibration cycle takes several seconds to run. Refer to the manufacturer documentation for further information on autocalibration.

Ground sense

Choose this check box to enable onboard compensation for ground potential differences. Refer to the manufacturer documentation for further information on ground sense.

Sampletime

Enter the base sample time or a multiple of the base sample time (- 1 means sample time is inherited)

PCI slot

If only one board of this type is in the target computer, enter - 1 to locate the board.

If two or more boards of this type are in the target computer, enter the bus number and the PCI slot number of the board associated with this driver block. Use the format **[BusNumber,SlotNumber]**. To determine the bus number and the PCI slot number, type:

```
tg = slrt;  
getPCIInfo(tg, 'installed')
```

External Websites

- www.generalstandards.com

General Standards PMC66-16AO16

Support for GS PMC66–16AO16 high-speed analog output board

Board

General Standards PMC66-16AO16

General Description

The PMC66-16AO16 is a high speed analog output board. You can purchase the board with either:

- Eight, twelve, or sixteen output channels
- None, 10 kHz, or 100 kHz analog filters on the output ports

Note: The analog output of this board contains a relatively high frequency component. Because of this, purchase the PMC66-16AO16 board with one of the filter options. If your board does not have a filter, its output will have very fast rise and fall times.

- Single-ended or differential output

The board simultaneously samples up to eight input channels from a single acquisition start. The board PMC form factor allows it to be attached to different adapters for use on PCI Express, PCI-X, cPCI-x, PCI, cPCI, or PC104-plus. You can have the board attached to your selected adapter.

The Simulink Real-Time block library supports this board with this driver block:

- General Standards 16AO16 Analog Output

You must use the General Standards 16AO16 Analog Output block with the **General Standards 24DSI12 Analog Input** for your Simulink Real-Time audio system model.

Board Characteristics

Board name

General Standards PMC-16AO16

Manufacturer

General Standards

Bus type

PCI, PCI Express, PCI-X, cPCI-x, cPCI, or
PC104-plus

Multiple block instance support

No

Multiple board support

Yes

External Websites

- www.generalstandards.com

General Standards 16AO16 Analog Output

General Standards 16AO16 Analog Output

Library

Simulink Real-Time Library for General Standards

Scaling Input to Output

I/O Module Output	Block Input Data Type	Scaling
Volts	Double	1

Block Parameters

Channel vector

This is a vector of channels. Specifies the output channels that the block works on. Each channel can appear only once in this vector. For example, to use the first, third, and fifth analog output channels, enter:

```
[1,3,5]
```

Output range

From the list, select an output range code for all D/A channels. This driver does not allow the selection of a different range for individual channels.

The following table is a list of the ranges for this driver and the corresponding range codes.

Input Range (V)	Range Code
-10 to +10	+ -10
-5 to +5	+ -5
-2.5 to +2.5	+ -2.5
-1.5 to +1.5	+ -1.5

Enable output ground sense hardware correction

Select this check box to enable the REMOTE GROUND SENSE bit in the Board Control Register (BCR). See the manufacturer documentation for more information about this function.

Frame Size, Sample Rate, and Sampletime

These three parameters are not independent but are related by:

$$\text{FrameSize} = \text{Sampletime} * \text{SampleRate}.$$

After you specify two of the parameters, the equation determines the third parameter. Enter -1 to have the block calculate that value from the other values.

For example, if you set **Frame Size** to 64 and **Sample Rate** to 44100, specify **Sampletime** as -1. It is computed internally to 0.001451247165533 seconds. This example model executes every 0.001451247165533 seconds, which is every 64 samples at 44.1 kHz.

Frame size (samples)

Enter the number of samples in one frame for each channel listed in **Channel vector**. An interrupt occurs on the board each time the board acquires this number of samples.

Sample rate

Enter the frequency at which the samples are taken, in Hz. This frequency must be in the range 2000 to 200000 Hz (2 kHz to 200 kHz).

Sample time (Frame completion time)

Enter the time between frame completions.

Autocal at download

Select this check box to execute the autocalibration cycle as part of the initial setup when the model is downloaded to the target computer. You might autocalibrate, for example, if the clock frequency changes when you download the model to the target computer. You can consider clearing this check box if you do not need to worry about exact voltage levels.

Note:

- The autocalibration cycle requires approximately 5 seconds to complete. Refer to the manufacturer documentation for further information on autocalibration.

- Autocalibration on the General Standards 16AO16 board might create undesirable output during model download.
-

External sync signal type

From the list, select one of the following to select a signal type for the clock output signal that can be connected to other input boards or to the PMC66-16AO16 output board.

LVDS

Low voltage differential signaling. Select this value for greater reliability, especially when using the General Standards twisted-pair ribbon cables.

TTL

See the manufacturer documentation for guidelines on using this signal type.

PCI slot (-1:autosearch)

If only one board of this type is in the target computer, enter - 1 to locate the board.

If two or more boards of this type are in the target computer, enter the bus number and the PCI slot number of the board associated with this driver block. Use the format **[BusNumber,SlotNumber]**.

To determine the bus number and the PCI slot number, type:

```
tg = slrt;  
getPCIInfo(tg, 'installed')
```

External Websites

- www.generalstandards.com

General Standards PMC-24DSI12

Support for GS PMC-24DSI12 high-speed analog input board.

Board

General Standards PMC-24DSI12

General Description

The PMC-24DSI12 is a high speed analog input board. You can purchase the board with either four, eight, or twelve input channels. The board PMC form factor allows it to be attached to different adapters for use on PCI Express, PCI-X, cPCI-x, PCI, cPCI, or PC104-plus. You can order the board attached to your selected adapter.

- This board operates in frame mode. To run the model with this board, you must perform additional setup procedures to route the buffer completion interrupt, as described in the following bullets.
- If your system requires more channels, you need to:
 - 1 Designate one board as the master board.
 - 2 Add slave boards PMC-24DSI12 to the target computer.
 - 3 Connect the output pins B29 and B30 of the master board to the clock input pins A29 and A30 of each slave board. Use twisted-pair wiring according to the LVDS directions.

The master board generates the interrupts from which to run the model.

- For frame audio output, route the clock output to a General Standards PMC66-16AO16 board. To do this
 - 1 Connect the output pins B29 and B30 from the last PMC-24DSI12 board to the input pins B33 and B34 pins of the PMC66-16AO16 board.
 - 2 Set the **Frame Size**, **Sample Rate**, and **Sampletime** parameters to the same value for each PMC-24DSI12 and PMC66-16AO16 block. For example, if **Sample Rate** is 41000, set the **Sample Rate** parameter to 44100 for each block.
- The PMC-24DSI12 uses DMA completion interrupts. To use this interrupt to run your model:

- 1 From the MATLAB Command Window, type:

```
tg = slrt;
getPCIInfo(tg, 'all')
.
```

This function returns a list of the installed PCI devices on your target computer.
- 2 Find the string **24DSI12** and note the **IRQ** for that board.
- 3 From the MATLAB Command Window, type the name of your Simulink model.

The Simulink model appears.
- 4 From the model, select **Simulation > Model Configuration Parameter**.

The Configuration Parameter dialog box is displayed for the model.
- 5 Select the **Code Generation** node.
- 6 In the **Simulink Real-Time Options** node, from the **Real-time interrupt source** list, select the same value as the **IRQ** value that `SimulinkRealTime.target.getPCIInfo` returns (see step 2).
- 7 From the **I/O board generating the interrupt** list, select the value **General Standards 24DSI12**. This specifies that the General Standards 24DSI12 board generates the interrupt.
- 8 In the **PCI slot (-1: autosearch) or ISA base address** field, set the PCI bus and slot for your interrupting board. If you have only one PMC-24DSI12 board, you can enter -1 to enable the driver to find the only board.
- 9 Click **OK** and save the model.

The Simulink Real-Time block library supports this board with this driver block:

- General Standards 16AO16 Analog Output

For frame audio output, use the General Standards PMC-24DSI12 Analog Input block with the General Standards 16AO16 Analog Output block for your Simulink Real-Time audio system model.

Board Characteristics

Board name

General Standards PMC-24DSI12

Manufacturer

Bus type

Multiple block instance support

Multiple board support

General Standards

PCI, PCI Express, PCI-X, cPCI-x, cPCI, or PC104-plus

One block per board

Yes. Only one can be the timing initiator; the others must be targets.

External Websites

- www.generalstandards.com

General Standards 24DSI12 Analog Input

General Standards 24DSI12 Analog Input

Library

Simulink Real-Time Library for General Standards

Scaling Output to Input

I/O Module Input	Block Output Data Type	Scaling
Volts	Double	1

Block Parameters

Channel vector

This is a vector of channels. Specifies the output channels that the block works on. Each channel can appear only once in this vector. For example, to use the first, third, and fifth analog input channels, enter:

```
[1,3,5]
```

Input range

From the list, select an input range code for all A/D channels. This driver does not allow the selection of a different range for individual channels.

The following table is a list of the ranges for this driver and the corresponding range codes.

Input Range (V)	Range Code
-10 to +10	+ -10
-5 to +5	+ -5
-2.5 to +2.5	+ -2.5

Frame Size, Sample Rate, and Sampletime

These three parameters are not independent but are related by:

$$\text{FrameSize} = \text{Sampletime} \times \text{SampleRate}.$$

After you specify two of the parameters, the equation determines the third parameter. Enter -1 to have the block calculate that value from the other values.

For example, if you set **Frame Size** to 64 and **Sample Rate** to 44100, specify **Sampletime** as -1. It is computed internally to 0.001451247165533 seconds. This example model executes every 0.001451247165533 seconds, which is every 64 samples at 44 kHz.

Frame size (samples)

Enter the number of samples in one frame for each channel listed in **Channel vector**. An interrupt occurs on the board each time the board acquires this number of samples.

Sample rate

Enter the frequency at which the samples are taken, in Hz. This frequency must be in the range 2000 to 200000 Hz (2 kHz to 200 kHz).

Sample time (Frame completion time)

Enter the time between frame completions.

Output format

From the list, select one of the following. The output value is of type double.

+ - Input Range (+-10 +-5 or +-2.5)

Specifies that the value is scaled to the input voltage range.

signed 32 bit integer $[-2^{23} \ 2^{23}-1]$

Specifies that the value is a direct 24-bit value converted to a floating integer.

Filter

From the list, select one of the following analog input filters:

- Low Frequency
- High Frequency

This parameter takes effect only if the **Sample rate** parameter exceeds 100 kHz. See the manufacturer documentation for more information.

Triggering mode

From the list, select one of the following:

Hardware clock/Initiator

Select this value if the board is the timing master.

Target

Select this value if the board is connected to another board that is the timing master.

Autocal at download

Select this check box to execute the autocalibration cycle as part of the initial setup when the model is downloaded to the target computer. You might autocalibrate, for example, after setting the acquisition frequency. You can consider clearing this check box if you do not need to worry about exact voltage levels.

Note: The autocalibration cycle requires approximately 5 seconds to complete. Refer to the manufacturer documentation for further information on autocalibration.

External sync signal type

From the list, select one of the following to select a signal type for the clock output signal that can be connected to other input boards or to the PMC66-16AO16 output board.

LVDS

Low voltage differential signaling. Select this value for greater reliability, especially when using the General Standards twisted-pair ribbon cables.

TTL

See the manufacturer documentation for guidelines on using this signal type.

PCI slot (-1:autosearch)

If only one board of this type is in the target computer, enter - 1 to locate the board.

If two or more boards of this type are in the target computer, enter the bus number and the PCI slot number of the board associated with this driver block. Use the format **[BusNumber, SlotNumber]**.

To determine the bus number and the PCI slot number, type:

```
tg = slrt;  
getPCIInfo(tg, 'installed')
```

External Websites

- www.generalstandards.com

HUMUSOFT Blocks

Humusoft AD622

HUMUSOFT AD622 board

Board

HUMUSOFT AD622

General Description

The AD622 is an I/O board with 8 single analog input (A/D) channels (14-bit), 8 analog output (D/A) channels (14-bit), 8 digital inputs, and 8 digital outputs.

The Simulink Real-Time block library supports this board with these driver blocks:

- Humusoft AD622 Analog Input (A/D)
- Humusoft AD622 Analog Output (D/A)
- Humusoft AD622 Digital Input
- Humusoft AD622 Digital Output

Board Characteristics

Board name	AD622
Manufacturer	HUMUSOFT
Bus type	PCI
Access method	Memory mapped
Multiple block instance support	Digital Input: Yes, Others: No
Multiple board support	Yes

External Websites

- www.humusoft.cz

Humusoft AD622 Analog Input (A/D)

HUMUSOFT AD622 Analog Input block

Library

Simulink Real-Time Library for HUMUSOFT

Scaling Input to Output

Hardware Input	Block Output Data Type	Scaling
Volts	Double	1

Block Parameters

Channel Vector

Enter numbers between 1 and 8. This driver allows the selection of individual channels in arbitrary order. The number of elements defines the number of channels used.

For example, to use the first, second, and fifth channels, enter

```
[1,2,5]
```

Number the channels beginning with 1, even if this board manufacturer starts numbering the channels with 0.

Sample time

Enter the base sample time or a multiple of the base sample time (-1 means sample time is inherited).

PCI slot (-1:autosearch)

If only one board of this type is in the target computer, enter -1 to locate the board.

If two or more boards of this type are in the target computer, enter the bus number and the PCI slot number of the board associated with this driver block. Use the format **[BusNumber,SlotNumber]**.

To determine the bus number and the PCI slot number, type:

```
tg = slrt;  
getPCIInfo(tg, 'installed')
```

External Websites

- www.humusoft.cz

Humusoft AD622 Analog Output (D/A)

HUMUSOFT AD622 Analog Output block

Library

Simulink Real-Time Library for HUMUSOFT

Scaling Input to Output

Hardware Output	Block Input Data Type	Scaling
Volts	Double	1

Block Parameters

Channel Vector

Enter numbers between 1 and 8. This driver allows the selection of individual channels in arbitrary order. The number of elements defines the number of channels used.

For example, to use the first, second, and fifth channels, enter

```
[1,2,5]
```

Number the channels beginning with 1, even if this board manufacturer starts numbering the channels with 0.

Sample time

Enter the base sample time or a multiple of the base sample time (-1 means sample time is inherited).

PCI slot (-1:autosearch)

If only one board of this type is in the target computer, enter -1 to locate the board.

If two or more boards of this type are in the target computer, enter the bus number and the PCI slot number of the board associated with this driver block. Use the format **[BusNumber,SlotNumber]**.

To determine the bus number and the PCI slot number, type:

```
tg = slrt;  
getPCIInfo(tg, 'installed')
```

External Websites

- www.humusoft.cz

Humusoft AD622 Digital Input

HUMUSOFT AD622 Digital Input block

Library

Simulink Real-Time Library for HUMUSOFT

Scaling Input to Output

Hardware Input	Block Output Data Type	Scaling
TTL	Double	< 0.8 = TTL low ≥ 0.8 = TTL high

Channel Vector

Enter numbers between 1 and 8. This driver allows the selection of individual channels in arbitrary order. The number of elements defines the number of channels used.

For example, to use the first, second, and fifth channels, enter

```
[1,2,5]
```

Number the channels beginning with 1, even if this board manufacturer starts numbering the channels with 0.

Sample time

Enter the base sample time or a multiple of the base sample time (- 1 means sample time is inherited).

PCI slot (-1:autosearch)

If only one board of this type is in the target computer, enter - 1 to locate the board.

If two or more boards of this type are in the target computer, enter the bus number and the PCI slot number of the board associated with this driver block. Use the format **[BusNumber, SlotNumber]**.

To determine the bus number and the PCI slot number, type:

```
tg = slrt;  
getPCIInfo(tg, 'installed')
```

External Websites

- www.humusoft.cz

Humusoft AD622 Digital Output

HUMUSOFT AD622 Digital Output block

Library

Simulink Real-Time Library for HUMUSOFT

Scaling Input to Output

Hardware Output	Block Input Data Type	Scaling
TTL	Double	< 0.5 = TTL low ≥ 0.5 = TTL high

Channel Vector

Enter numbers between 1 and 8. This driver allows the selection of individual channels in arbitrary order. The number of elements defines the number of channels used.

For example, to use the first, second, and fifth channels, enter

```
[1,2,5]
```

Number the channels beginning with 1, even if this board manufacturer starts numbering the channels with 0.

Sample time

Enter the base sample time or a multiple of the base sample time (- 1 means sample time is inherited).

PCI slot (-1:autosearch)

If only one board of this type is in the target computer, enter - 1 to locate the board.

If two or more boards of this type are in the target computer, enter the bus number and the PCI slot number of the board associated with this driver block. Use the format **[BusNumber, SlotNumber]**.

To determine the bus number and the PCI slot number, type:

```
tg = slrt;  
getPCIInfo(tg, 'installed')
```

External Websites

- www.humusoft.cz

Humusoft MF624

HUMUSOFT MF624 board

Board

HUMUSOFT MF624

General Description

The MF624 is an I/O board with 8 single analog input (A/D) channels (14-bit), 8 analog output (D/A) channels (14-bit), 8 digital inputs, and 8 digital outputs. It also has 5 counters/timers and 4 quadrature encoder inputs with single-ended or differential input.

The Simulink Real-Time block library supports this board with these driver blocks:

- Humusoft MF624 Analog Input (A/D)
- Humusoft MF624 Analog Output (D/A)
- Humusoft MF624 Digital Input
- Humusoft MF624 Digital Output
- Humusoft MF624 Counter Input
- Humusoft MF624 Encoder Input
- Humusoft MF624 PWM Output

Board Characteristics

Board name	MF624
Manufacturer	HUMUSOFT
Bus type	PCI
Access method	Memory mapped
Multiple block instance support	Digital Input: Yes, Others: No
Multiple board support	Yes

External Websites

- www.humusoft.cz

Humusoft MF624 Analog Input (A/D)

HUMUSOFT MF624 Analog Input block

Library

Simulink Real-Time Library for HUMUSOFT

Scaling Input to Output

Hardware Input	Block Output Data Type	Scaling
Volts	Double	1

Block Parameters

Channel Vector

Enter numbers between 1 and 8. This driver allows the selection of individual channels in arbitrary order. The number of elements defines the number of channels used.

For example, to use the first, second, and fifth channels, enter

```
[1,2,5]
```

Number the channels beginning with 1, even if this board manufacturer starts numbering the channels with 0.

Sample time

Enter the base sample time or a multiple of the base sample time (-1 means sample time is inherited).

PCI slot (-1:autosearch)

If only one board of this type is in the target computer, enter -1 to locate the board.

If two or more boards of this type are in the target computer, enter the bus number and the PCI slot number of the board associated with this driver block. Use the format **[BusNumber,SlotNumber]**.

To determine the bus number and the PCI slot number, type:

```
tg = slrt;  
getPCIInfo(tg, 'installed')
```

External Websites

- www.humusoft.cz

Humusoft MF624 Analog Output (D/A)

HUMUSOFT MF624 Analog Output block

Library

Simulink Real-Time Library for HUMUSOFT

Scaling Input to Output

Hardware Output	Block Input Data Type	Scaling
Volts	Double	1

Block Parameters

Channel Vector

Enter numbers between 1 and 8. This driver allows the selection of individual channels in arbitrary order. The number of elements defines the number of channels used.

For example, to use the first, second, and fifth channels, enter

```
[1,2,5]
```

Number the channels beginning with 1, even if this board manufacturer starts numbering the channels with 0.

Sample time

Enter the base sample time or a multiple of the base sample time (-1 means sample time is inherited).

PCI slot (-1:autosearch)

If only one board of this type is in the target computer, enter -1 to locate the board.

If two or more boards of this type are in the target computer, enter the bus number and the PCI slot number of the board associated with this driver block. Use the format **[BusNumber,SlotNumber]**.

To determine the bus number and the PCI slot number, type:

```
tg = slrt;  
getPCIInfo(tg, 'installed')
```

External Websites

- www.humusoft.cz

Humusoft MF624 Digital Input

HUMUSOFT MF624 Digital Input block

Library

Simulink Real-Time Library for HUMUSOFT

Scaling Input to Output

Hardware Input	Block Output Data Type	Scaling
TTL	Double	< 0.8 = TTL low ≥ 0.8 = TTL high

Channel Vector

Enter numbers between 1 and 8. This driver allows the selection of individual channels in arbitrary order. The number of elements defines the number of channels used.

For example, to use the first, second, and fifth channels, enter

```
[1,2,5]
```

Number the channels beginning with 1, even if this board manufacturer starts numbering the channels with 0.

Sample time

Enter the base sample time or a multiple of the base sample time (- 1 means sample time is inherited).

PCI slot (-1:autosearch)

If only one board of this type is in the target computer, enter - 1 to locate the board.

If two or more boards of this type are in the target computer, enter the bus number and the PCI slot number of the board associated with this driver block. Use the format **[BusNumber, SlotNumber]**.

To determine the bus number and the PCI slot number, type:

```
tg = slrt;  
getPCIInfo(tg, 'installed')
```

External Websites

- www.humusoft.cz

Humusoft MF624 Digital Output

HUMUSOFT MF624 Digital Output block

Library

Simulink Real-Time Library for HUMUSOFT

Scaling Input to Output

Hardware Output	Block Input Data Type	Scaling
TTL	Double	< 0.5 = TTL low ≥ 0.5 = TTL high

Channel Vector

Enter numbers between 1 and 8. This driver allows the selection of individual channels in arbitrary order. The number of elements defines the number of channels used.

For example, to use the first, second, and fifth channels, enter

```
[1,2,5]
```

Number the channels beginning with 1, even if this board manufacturer starts numbering the channels with 0.

Sample time

Enter the base sample time or a multiple of the base sample time (- 1 means sample time is inherited).

PCI slot (-1:autosearch)

If only one board of this type is in the target computer, enter - 1 to locate the board.

If two or more boards of this type are in the target computer, enter the bus number and the PCI slot number of the board associated with this driver block. Use the format **[BusNumber, SlotNumber]**.

To determine the bus number and the PCI slot number, type:

```
tg = slrt;  
getPCIInfo(tg, 'installed')
```

External Websites

- www.humusoft.cz

Humusoft MF624 Counter Input

HUMUSOFT MF624 Counter Input block

Library

Simulink Real-Time Library for HUMUSOFT

Scaling Input to Output

Hardware Output	Block Input Data Type	Scaling
TTL	Double	$< 0.5 = \text{TTL low}$ $\geq 0.5 = \text{TTL high}$

Channel Vector

Enter numbers between 1 and 4. This driver allows the selection of individual channels in arbitrary order. The number of elements defines the number of channels used.

For example, to use the first, second, and fourth , enter

[1,2,4]

Number the lines beginning with 1, even if this board manufacturer starts numbering the lines with 0.

Reset after read

From the list, select:

- **No** — Do not reset counter after reading. Counting continues without stop.
- **Yes** — Reset counter after reading. Read number of pulses per sample period.

Clock active edge

From the list, select:

- **Rising** — Increment the counter on the rising edge of the signal.
- **Falling** — Increment the counter on the falling edge of the signal.

- **Either** — Increment the counter on both edges of the signal. For example, with periodic signals, count twice the number of pulses (rising or falling).

Sample time

Enter the base sample time or a multiple of the base sample time (- 1 means sample time is inherited).

PCI slot (-1:autosearch)

If only one board of this type is in the target computer, enter - 1 to locate the board.

If two or more boards of this type are in the target computer, enter the bus number and the PCI slot number of the board associated with this driver block. Use the format **[BusNumber,SlotNumber]**.

To determine the bus number and the PCI slot number, type:

```
tg = slrt;  
getPCIInfo(tg, 'installed')
```

External Websites

- www.humusoft.cz

Humusoft MF624 Encoder Input

HUMUSOFT MF624 Encoder Input block

Library

Simulink Real-Time Library for HUMUSOFT

Scaling Input to Output

Hardware Output	Block Input Data Type	Scaling
TTL	Double	$< 0.5 = \text{TTL low}$ $\geq 0.5 = \text{TTL high}$

Channel Vector

Enter numbers between 1 and 4. This driver allows the selection of individual channels in arbitrary order. The number of elements defines the number of channels used.

For example, to use the first, second, and fourth , enter

[1,2,4]

Number the lines beginning with 1, even if this board manufacturer starts numbering the lines with 0.

Input Filter Vector (0=Off, 1=On)

Enter a vector of 0s and 1s, one for each encoder channel in **Channel Vector**. The length of this vector must be the same as the length of **Channel Vector**. Each **Input Filter Vector** element corresponds to its equivalent in **Channel Vector**. Enter 1 to filter, or 0 to not filter the measured signal. Use this parameter to eliminate short spurious pluses. The input noise filters are disabled by default.

- 0 — Disables the input noise filter.
- 1 — Enables the input noise filter.

Index Function Vector (see help)

Specify the function of the I input (index). Enter a vector of values, one for each PWM channel in **Channel Vector**. The length of this vector must be the same as the length of **Channel Vector**. Each **Input Function Vector** element corresponds to its equivalent in **Channel Vector**. Enter one of the following values for each channel:

Value	Operation
0	No function (disabled)
1	Reset counter when low
2	Reset counter when high
3	Reset counter on rising edge
4	Reset counter on falling edge
5	Reset counter on either edge
6	Enable counting when high
7	Enable counting when low

Sample time

Enter the base sample time or a multiple of the base sample time (- 1 means sample time is inherited).

PCI slot (-1:autosearch)

If only one board of this type is in the target computer, enter - 1 to locate the board.

If two or more boards of this type are in the target computer, enter the bus number and the PCI slot number of the board associated with this driver block. Use the format [**BusNumber**, **SlotNumber**].

To determine the bus number and the PCI slot number, type:

```
tg = slrt;
getPCIInfo(tg, 'installed')
```

External Websites

- www.humusoft.cz

Humusoft MF624 PWM Output

HUMUSOFT MF624 PWM Output block

Library

Simulink Real-Time Library for HUMUSOFT

Scaling Input to Output

Hardware Output	Block Input Data Type	Scaling
TTL	Double	< 0.5 = TTL low ≥ 0.5 = TTL high

Channel Vector

Enter numbers between 1 and 4. This driver allows the selection of individual channels in arbitrary order. The number of elements defines the number of channels used.

For example, to use the first, second, and fourth , enter

[1,2,4]

Number the lines beginning with 1, even if this board manufacturer starts numbering the lines with 0.

Sample time

Enter the base sample time or a multiple of the base sample time (- 1 means sample time is inherited).

PCI slot (-1:autosearch)

If only one board of this type is in the target computer, enter - 1 to locate the board.

If two or more boards of this type are in the target computer, enter the bus number and the PCI slot number of the board associated with this driver block. Use the format **[BusNumber, SlotNumber]**.

To determine the bus number and the PCI slot number, type:

```
tg = slrt;  
getPCIInfo(tg, 'installed')
```

External Websites

- www.humusoft.cz

Humusoft MF634

HUMUSOFT MF634 board

Board

HUMUSOFT MF634

General Description

The MF634 is an I/O board with 8 single analog input (A/D) channels (14-bit), 8 analog output (D/A) channels (14-bit), 8 digital inputs, and 8 digital outputs. It also has 5 counters/timers and 4 quadrature encoder inputs with single-ended or differential input.

The Simulink Real-Time block library supports this board with these driver blocks:

- Humusoft MF634 Analog Input (A/D)
- Humusoft MF634 Analog Output (D/A)
- Humusoft MF634 Digital Input
- Humusoft MF634 Digital Output
- Humusoft MF634 Counter Input
- Humusoft MF634 Encoder Input
- Humusoft MF634 PWM Output

Board Characteristics

Board name	MF634
Manufacturer	HUMUSOFT
Bus type	PCI
Access method	Memory mapped
Multiple block instance support	Digital Input: Yes, Others: No
Multiple board support	Yes

External Websites

- www.humusoft.cz

Humusoft MF634 Analog Input (A/D)

HUMUSOFT MF634 Analog Input block

Library

Simulink Real-Time Library for HUMUSOFT

Scaling Input to Output

Hardware Input	Block Output Data Type	Scaling
Volts	Double	1

Block Parameters

Channel Vector

Enter numbers between 1 and 8. This driver allows the selection of individual channels in arbitrary order. The number of elements defines the number of channels used.

For example, to use the first, second, and fifth channels, enter

```
[1,2,5]
```

Number the channels beginning with 1, even if this board manufacturer starts numbering the channels with 0.

Sample time

Enter the base sample time or a multiple of the base sample time (-1 means sample time is inherited).

PCI slot (-1:autosearch)

If only one board of this type is in the target computer, enter -1 to locate the board.

If two or more boards of this type are in the target computer, enter the bus number and the PCI slot number of the board associated with this driver block. Use the format **[BusNumber,SlotNumber]**.

To determine the bus number and the PCI slot number, type:

```
tg = slrt;  
getPCIInfo(tg, 'installed')
```

External Websites

- www.humusoft.cz

Humusoft MF634 Analog Output (D/A)

HUMUSOFT MF634 Analog Output block

Library

Simulink Real-Time Library for HUMUSOFT

Scaling Input to Output

Hardware Output	Block Input Data Type	Scaling
Volts	Double	1

Block Parameters

Channel Vector

Enter numbers between 1 and 8. This driver allows the selection of individual channels in arbitrary order. The number of elements defines the number of channels used.

For example, to use the first, second, and fifth channels, enter

```
[1,2,5]
```

Number the channels beginning with 1, even if this board manufacturer starts numbering the channels with 0.

Sample time

Enter the base sample time or a multiple of the base sample time (-1 means sample time is inherited).

PCI slot (-1:autosearch)

If only one board of this type is in the target computer, enter -1 to locate the board.

If two or more boards of this type are in the target computer, enter the bus number and the PCI slot number of the board associated with this driver block. Use the format **[BusNumber,SlotNumber]**.

To determine the bus number and the PCI slot number, type:

```
tg = slrt;  
getPCIInfo(tg, 'installed')
```

External Websites

- www.humusoft.cz

Humusoft MF634 Digital Input

HUMUSOFT MF634 Digital Input block

Library

Simulink Real-Time Library for HUMUSOFT

Scaling Input to Output

Hardware Input	Block Output Data Type	Scaling
TTL	Double	< 0.8 = TTL low ≥ 0.8 = TTL high

Channel Vector

Enter numbers between 1 and 8. This driver allows the selection of individual channels in arbitrary order. The number of elements defines the number of channels used.

For example, to use the first, second, and fifth channels, enter

```
[1,2,5]
```

Number the channels beginning with 1, even if this board manufacturer starts numbering the channels with 0.

Sample time

Enter the base sample time or a multiple of the base sample time (- 1 means sample time is inherited).

PCI slot (-1:autosearch)

If only one board of this type is in the target computer, enter - 1 to locate the board.

If two or more boards of this type are in the target computer, enter the bus number and the PCI slot number of the board associated with this driver block. Use the format **[BusNumber, SlotNumber]**.

To determine the bus number and the PCI slot number, type:

```
tg = slrt;  
getPCIInfo(tg, 'installed')
```

External Websites

- www.humusoft.cz

Humusoft MF634 Digital Output

HUMUSOFT MF634 Digital Output block

Library

Simulink Real-Time Library for HUMUSOFT

Scaling Input to Output

Hardware Output	Block Input Data Type	Scaling
TTL	Double	< 0.5 = TTL low ≥ 0.5 = TTL high

Channel Vector

Enter numbers between 1 and 8. This driver allows the selection of individual channels in arbitrary order. The number of elements defines the number of channels used.

For example, to use the first, second, and fifth channels, enter

```
[1,2,5]
```

Number the channels beginning with 1, even if this board manufacturer starts numbering the channels with 0.

Sample time

Enter the base sample time or a multiple of the base sample time (- 1 means sample time is inherited).

PCI slot (-1:autosearch)

If only one board of this type is in the target computer, enter - 1 to locate the board.

If two or more boards of this type are in the target computer, enter the bus number and the PCI slot number of the board associated with this driver block. Use the format **[BusNumber, SlotNumber]**.

To determine the bus number and the PCI slot number, type:

```
tg = slrt;  
getPCIInfo(tg, 'installed')
```

External Websites

- www.humusoft.cz

Humusoft MF634 Counter Input

HUMUSOFT MF634 Counter Input block

Library

Simulink Real-Time Library for HUMUSOFT

Scaling Input to Output

Hardware Output	Block Input Data Type	Scaling
TTL	Double	$< 0.5 = \text{TTL low}$ $\geq 0.5 = \text{TTL high}$

Channel Vector

Enter numbers between 1 and 4. This driver allows the selection of individual channels in arbitrary order. The number of elements defines the number of channels used.

For example, to use the first, second, and fourth , enter

[1,2,4]

Number the lines beginning with 1, even if this board manufacturer starts numbering the lines with 0.

Reset after read

From the list, select:

- **No** — Do not reset counter after reading. Counting continues without stop.
- **Yes** — Reset counter after reading. Read number of pulses per sample period.

Clock active edge

From the list, select:

- **Rising** — Increment the counter on the rising edge of the signal.
- **Falling** — Increment the counter on the falling edge of the signal.

- **Either** — Increment the counter on both edges of the signal. For example, with periodic signals, count twice the number of pulses (rising or falling).

Sample time

Enter the base sample time or a multiple of the base sample time (- 1 means sample time is inherited).

PCI slot (-1:autosearch)

If only one board of this type is in the target computer, enter - 1 to locate the board.

If two or more boards of this type are in the target computer, enter the bus number and the PCI slot number of the board associated with this driver block. Use the format **[BusNumber,SlotNumber]**.

To determine the bus number and the PCI slot number, type:

```
tg = slrt;  
getPCIInfo(tg, 'installed')
```

External Websites

- www.humusoft.cz

Humusoft MF634 Encoder Input

HUMUSOFT MF634 Encoder Input block

Library

Simulink Real-Time Library for HUMUSOFT

Scaling Input to Output

Hardware Output	Block Input Data Type	Scaling
TTL	Double	$< 0.5 = \text{TTL low}$ $\geq 0.5 = \text{TTL high}$

Channel Vector

Enter numbers between 1 and 4. This driver allows the selection of individual channels in arbitrary order. The number of elements defines the number of channels used.

For example, to use the first, second, and fourth , enter

[1,2,4]

Number the lines beginning with 1, even if this board manufacturer starts numbering the lines with 0.

Input Filter Vector (0=Off, 1=On)

Enter a vector of 0s and 1s, one for each encoder channel in **Channel Vector**. The length of this vector must be the same as the length of **Channel Vector**. Each **Input Filter Vector** element corresponds to its equivalent in **Channel Vector**. Enter 1 to filter, or 0 to not filter the measured signal. Use this parameter to eliminate short spurious pluses. The input noise filters are disabled by default.

- 0 — Disables the input noise filter.
- 1 — Enables the input noise filter.

Index Function Vector (see help)

Specify the function of the I input (index). Enter a vector of values, one for each PWM channel in **Channel Vector**. The length of this vector must be the same as the length of **Channel Vector**. Each **Input Function Vector** element corresponds to its equivalent in **Channel Vector**. Enter one of the following values for each channel:

Value	Operation
0	No function (disabled)
1	Reset counter when low
2	Reset counter when high
3	Reset counter on rising edge
4	Reset counter on falling edge
5	Reset counter on either edge
6	Enable counting when high
7	Enable counting when low

Sample time

Enter the base sample time or a multiple of the base sample time (- 1 means sample time is inherited).

PCI slot (-1:autosearch)

If only one board of this type is in the target computer, enter - 1 to locate the board.

If two or more boards of this type are in the target computer, enter the bus number and the PCI slot number of the board associated with this driver block. Use the format [**BusNumber**, **SlotNumber**].

To determine the bus number and the PCI slot number, type:

```
tg = slrt;
getPCIInfo(tg, 'installed')
```

External Websites

- www.humusoft.cz

Humusoft MF634 PWM Output

HUMUSOFT MF634 PWM Output block

Library

Simulink Real-Time Library for HUMUSOFT

Scaling Input to Output

Hardware Output	Block Input Data Type	Scaling
TTL	Double	< 0.5 = TTL low ≥ 0.5 = TTL high

Channel Vector

Enter numbers between 1 and 4. This driver allows the selection of individual channels in arbitrary order. The number of elements defines the number of channels used.

For example, to use the first, second, and fourth , enter

[1,2,4]

Number the lines beginning with 1, even if this board manufacturer starts numbering the lines with 0.

Sample time

Enter the base sample time or a multiple of the base sample time (- 1 means sample time is inherited).

PCI slot (-1:autosearch)

If only one board of this type is in the target computer, enter - 1 to locate the board.

If two or more boards of this type are in the target computer, enter the bus number and the PCI slot number of the board associated with this driver block. Use the format **[BusNumber, SlotNumber]**.

To determine the bus number and the PCI slot number, type:

```
tg = slrt;  
getPCIInfo(tg, 'installed')
```

External Websites

- www.humusoft.cz

**MathWorks, Measurement
Computing, MIL-STD-1553, MPL**

MathWorks

- “xPC TargetBox Support” on page 41-2
- “xPC TargetBox I/O Options” on page 41-3

xPC TargetBox Support

This topic describes the xPC TargetBox boards and blocks supported by Simulink Real-Time. xPC TargetBox is an industrial target computer that is optimized for executing real-time code generated with Simulink Real-Time, Simulink Coder, and a C/C++ compiler. MathWorks supplies and supports the blocks and documentation for users who already own this system.

xPC TargetBox is not available from MathWorks. Consider Speedgoat for other recommendations. See “Speedgoat Real-Time Target Machines” on page 51-2.

xPC TargetBox I/O Options

The following table lists the supported Simulink Real-Time boards that correspond to xPC TargetBox I/O options.

I/O Option Name	Simulink Real-Time Equivalent
xPC TargetBox IO 301	Diamond Diamond-MM-32-AT
xPC TargetBox IO 302	Diamond Ruby-MM-1612
xPC TargetBox IO 303	Diamond Ruby-MM-416
xPC TargetBox IO 304	Diamond Onyx-MM
xPC TargetBox IO 305	Diamond Quartz-MM-10
xPC TargetBox IO 306	Real Time Devices DM6814
xPC TargetBox IO 308	Softing CAN-AC2-104 with SJA1000 Setup
xPC TargetBox IO 309	MPL PATI

Measurement Computing

This topic describes Measurement Computing (formerly Computer Boards) I/O boards supported by the Simulink Real-Time product (www.measurementcomputing.com)

Measurement Computing PC104-DAC06 (/12)

Support for the MC PC104–DAC06 (/12) I/O board

Board

Measurement Computing PC104-DAC06 (/12)

General Description

The PC104-DAC06 (12) is an I/O board with 6 analog output (D/A) channels (12-bit).

The Simulink Real-Time block library supports this board with this driver block:

- Measurement Computing PC104-DAC06 (/12) Analog Output (D/A)

Board Characteristics

Board name	PC104-DAC06 (/12)
Manufacturer	Measurement Computing
Bus type	PC/104
Access method	I/O mapped
Multiple block instance support	No
Multiple board support	Yes

External Websites

- www.measurementcomputing.com

Measurement Computing PC104-DAC06 (/12) Analog Output (D/A)

PC104-DAC06 (/12) Analog Output block

Library

Simulink Real-Time Library for Measurement Computing

Scaling Input to Output

I/O Module Output	Block Input Data Type	Scaling
Volts	Double	1

Block Parameters

Channel vector

Enter numbers between 1 and 6. This board allows the selection of individual D/A channels in arbitrary order. The number of elements defines the number of D/A channels used. For example, to use the first and second analog output channels, enter

[1,2]

Number the channels beginning with 1 even if this board manufacturer starts numbering the channels with 0.

Range vector

Range code for each of the channels in the channel vector. The range vector must be the same length as the channel vector. This board allows the range of each channel to be different.

The following table is a list of the ranges for this driver and the corresponding range codes.

Input Range (V)	Range Code
-10 to +10	-10
-5 to +5	-5
0 to +10	10
0 to +5	5

For example, if the first channel is -10 to +10 volts and the second channel is 0 to +5 volts, enter

[-10,5]

The range settings must correspond to the jumper settings on the board.

Reset vector

The reset vector controls the behavior of the channel at model termination. Enter a scalar or a vector that is the same length as the channel vector. If you specify a scalar value, that setting is replicated over the channel vector. If you specify a value of 1, the corresponding channel is reset to the value specified in the initial value vector. If you specify a value of 0, the channel remains at the last value attained while the model was running.

Initial value vector

The initial value vector contains the initial voltage values for the output channels. Enter a scalar or a vector that is the same length as the channel vector. If you specify a scalar value, that value is replicated as the initial value over the channel vector. The channels are set to the initial values between the time the model is downloaded and the time it is started.

Sample time

Enter the base sample time or a multiple of the base sample time (- 1 means sample time is inherited).

Base address

Enter the base address of the board. It is important that this entry corresponds to the DIP switch settings on the board. For example, if the base address is 300 (hexadecimal), enter

0x300

The jumpers by the range DIP switches on the board must be in the XFER position. The Wait-State jumper has to be in the off position.

External Websites

- www.measurementcomputing.com

Measurement Computing PC104-DAS16JR/12

Support for the MC PC104–DAS16JR/12 I/O board

Board

Measurement Computing PC104-DAS16JR/12

General Description

The PC104-DAS16JR/12 is an I/O board with 16 single or 8 differential analog input channels (12-bit) with a maximum sample rate of 150 kHz, 4 digital input lines and 4 digital output lines.

The Simulink Real-Time block library supports this board with these driver blocks:

- Measurement Computing PC104-DAS16JR/12 Analog Input (A/D)
- Measurement Computing PC104-DAS16JR/12 Digital Input
- Measurement Computing PC104-DAS16JR/12 Digital Output

Board Characteristics

Board name	PC104-DAS16JR/12
Manufacturer	Measurement Computing
Bus type	PC/104
Access method	I/O mapped
Multiple block instance support	No
Multiple board support	Yes

External Websites

- www.measurementcomputing.com

Measurement Computing PC104-DAS16JR/12 Analog Input (A/D)

PC104-DAS16JR/12 Analog Input block

Library

Simulink Real-Time Library for Measurement Computing

Scaling Input to Output

I/O Module Input	Block Output Data Type	Scaling
Volts	Double	1

Block Parameters

Number of Channels

If you select 16 channels (**Input coupling** parameter set to 16 **single-ended channels**) enter a number between 1 and 16 to select the number of A/D channels used. If you select eight channels (**Input coupling** parameter set to 8 **differential channels**) enter a number between 1 and 8. This driver does not allow the selection of individual channels or to mix single-ended and differential inputs.

Number the lines beginning with 1 even if this board manufacturer numbers the lines beginning with 0.

Range

From the list, choose either $\pm 10V$ (-10 volts to +10 volts), $\pm 5V$, $\pm 2.5V$, $\pm 1.25V$, $\pm 0.625V$, $0-10V$, $0-5V$, $0-2.5V$, or $0-1.25V$. This driver does not allow the selection of a different range for each channel.

Input coupling

From the list, select one from the following list of input modes:

- Single-ended channels (16 channels)
- Differential channels (8 channels)

This choice must correspond to the MUX-switch setting on the board.

Sample time

Enter the base sample time or a multiple of the base sample time (- 1 means sample time is inherited).

Base address

Enter the base address of the board. This entry must correspond to the DIP switch setting on the board. For example, if the DIP switch setting is 300 (hexadecimal), enter 0x300.

External Websites

- www.measurementcomputing.com

Measurement Computing PC104-DAS16JR/12 Digital Input

PC104-DAS16JR/12 Digital Input block

Library

Simulink Real-Time Library for Measurement Computing

Scaling Input to Output

I/O Module Input	Block Output Data Type	Scaling
TTL	Double	TTL low = 0.0 TTL high = 1.0

Block Parameters

Number of Channels

Enter a number between 1 and 4 to select the number of digital input lines used. This driver does not allow the selection of individual digital input lines.

Sample time

Enter the base sample time or a multiple of the base sample time (- 1 means sample time is inherited).

Base address

Enter the base address of the board. This entry must correspond to the DIP switch setting on the board. For example, if the DIP switch setting is 300 (hexadecimal), enter 0x300.

External Websites

- www.measurementcomputing.com

Measurement Computing PC104-DAS16JR/12 Digital Output

PC104-DAS16JR/12 Digital Output block

Library

Simulink Real-Time Library for Measurement Computing

Scaling Input to Output

I/O Module Output	Block Input Data Type	Scaling
TTL	Double	< 0.5 = TTL low ≥ 0.5 = TTL high

Block Parameters

Number of Channels

Enter a number between 1 and 4 to select the number of digital output lines used. This driver does not allow the selection of individual digital output lines.

Sample time

Enter the base sample time or a multiple of the base sample time (- 1 means sample time is inherited).

Base address

Enter the base address of the board. It is important that this entry corresponds to the DIP switch settings on the board. For example, if the base address is 300 (hexadecimal), enter

0x300

The remaining switch and jumper settings do not influence the running of the Simulink Real-Time software.

External Websites

- www.measurementcomputing.com

Measurement Computing PC104-DAS16JR/16

Support for the MC PC104–DAS16JR/16 I/O board

Board

Measurement Computing PC104-DAS16JR/16

General Description

The PC104-DAS16JR/16 is an I/O board with 16 single or 8 differential analog input (A/D) channels (16-bit) with a maximum sample rate of 100 kHz, 4 digital input lines and 4 digital output lines.

The Simulink Real-Time block library supports this board with these driver blocks:

- Measurement Computing PC104-DAS16JR/16 Analog Input (A/D)
- Measurement Computing PC104-DAS16JR/16 Digital Input
- Measurement Computing PC104-DAS16JR/16 Digital Output

Board Characteristics

Board name	PC104-DAS16JR/16
Manufacturer	Measurement Computing
Bus type	PC/104
Access method	I/O mapped
Multiple block instance support	No
Multiple board support	Yes

External Websites

- www.measurementcomputing.com

Measurement Computing PC104-DAS16JR/16 Analog Input (A/D)

PC104-DAS16JR/16 Analog Input block

Library

Simulink Real-Time Library for Measurement Computing

Scaling Input to Output

I/O Module Input	Block Output Data Type	Scaling
Volts	Double	1

Block Parameters

Number of Channels

If you select 16 channels (**Input coupling** parameter set to 16 **single-ended channels**) enter a number between 1 and 16 to select the number of A/D channels used. If you select eight channels (**Input coupling** parameter set to 8 **differential channels**) enter a number between 1 and 8. This driver does not allow the selection of individual channels or to mix single-ended and differential inputs.

Number the lines beginning with 1 even if this board manufacturer numbers the lines beginning with 0.

Range

From the list, choose either +- 10V (-10 volts to +10 volts), +- 5V, +- 2.5V, +- 1.25V, +- 0.625V, 0-10V, 0-5V, 0-2.5V, or 0-1.25V. This driver does not allow the selection of different range for each channel.

Input coupling

From the list, select one from the following list of input modes:

- Single-ended channels (16 channels)
- Differential channels (8 channels)

This choice must correspond to the MUX-switch setting on the board.

Sample time

Enter the base sample time or a multiple of the base sample time (- 1 means sample time is inherited).

Base address

Enter the base address of the board. This entry must correspond to the DIP switch setting on the board. For example, if the DIP switch setting is 300 (hexadecimal), enter 0x300.

External Websites

- www.measurementcomputing.com

Measurement Computing PC104-DAS16JR/16 Digital Input

PC104-DAS16JR/16 Digital Input block

Library

Simulink Real-Time Library for Measurement Computing

Scaling Input to Output

I/O Module Input	Block Output Data Type	Scaling
TTL	Double	TTL low = 0.0 TTL high = 1.0

Block Parameters

Number of Channels

Enter a number between 1 and 4 to select the number of digital input lines used. This driver does not allow the selection of individual digital input lines.

Sample time

Enter the base sample time or a multiple of the base sample time (- 1 means sample time is inherited).

Base address

Enter the base address of the board. This entry must correspond to the DIP switch setting on the board. For example, if the DIP switch setting is 300 (hexadecimal), enter 0x300.

External Websites

- www.measurementcomputing.com

Measurement Computing PC104-DAS16JR/16 Digital Output

PC104-DAS16JR/16 Digital Output

Library

Simulink Real-Time Library for Measurement Computing

Scaling Input to Output

I/O Module Output	Block Input Data Type	Scaling
TTL	Double	< 0.5 = TTL low ≥ 0.5 = TTL high

Block Parameters

Number of Channels

Enter a number between 1 and 4 to select the number of digital output lines used. This driver does not allow the selection of individual digital output lines.

Sample time

Enter the base sample time or a multiple of the base sample time (- 1 means sample time is inherited).

Base address

Enter the base address of the board. This entry must correspond to the DIP switch setting on the board. For example, if the DIP switch setting is 300 (hexadecimal), enter 0x300.

External Websites

- www.measurementcomputing.com

Measurement Computing PC104-DIO48

Support for the MC PC104–DIO48 I/O board

Board

Measurement Computing PC104-DIO48

General Description

The PC104-DIO48 is an I/O board with 48 digital I/O lines.

The Simulink Real-Time block library supports this board with these driver blocks:

- Measurement Computing PC104-DIO48 Digital Input
- Measurement Computing PC104-DIO48 Digital Output

Board Characteristics

Board name	PC104-DIO48
Manufacturer	Measurement Computing
Bus type	PC/104
Access method	I/O mapped
Multiple block instance support	No
Multiple board support	Yes

External Websites

- www.measurementcomputing.com

Measurement Computing PC104-DIO48 Digital Input

PC104-DIO48 Digital Input block

Library

Simulink Real-Time Library for Measurement Computing

Note

The CIO-DIO48 has two 8255 chips (1,2). Each chip has three ports (A,B,C). Each port has a maximum of 8 digital I/O lines that can be configured as inputs or outputs. Use a separate driver block for each port. By selecting the digital input driver block, the port is configured as input.

Scaling Input to Output

I/O Module Input	Block Output Data Type	Scaling
TTL	Double	TTL low = 0.0 TTL high = 1.0

Block Parameters

Channel vector

Enter numbers between 1 and 8 to select the digital input lines used with this port. This driver allows the selection of individual digital input lines in arbitrary order. The number of elements defines the number of digital lines used.

For example, to use all of the digital inputs for one port, enter

```
[1,2,3,4,5,6,7,8]
```

Number the lines beginning with 1 even if this board manufacturer numbers the lines beginning with 0.

Port

From the list choose either **A**, **B**, or **C**. The I/O board has two 8255 chips with 3 ports. The **Port** parameter defines which port of the 8255 chip is used for this driver block. Each port has a maximum of 8 digital lines that can be configured as inputs or outputs depending on which driver block is chosen. In each case, one block is required for each port.

Chip

From the list choose **1** or **2**. The **Chip** parameter defines which of the two 8255 chips is used.

Sample time

Enter the base sample time or a multiple of the base sample time (- 1 means sample time is inherited).

Base address

Enter the base address of the board. This entry must correspond to the DIP switch setting on the board. For example, if the DIP switch setting is 300 (hexadecimal), enter 0x300.

External Websites

- www.measurementcomputing.com

Measurement Computing PC104-DIO48 Digital Output

PC104-DIO48 Digital Output block

Library

Simulink Real-Time Library for Measurement Computing

Note

The PC104-DIO48 has two 8255 chips (1,2). Each chip has three ports (A,B,C). Each port has a maximum of 8 digital I/O lines that can be configured as inputs or outputs. Use a separate driver block for each port. By selecting the digital output driver block, the port is configured as output.

Scaling Input to Output

I/O Module Output	Block Input Data Type	Scaling
TTL	Double	< 0.5 = TTL low ≥ 0.5 = TTL high

Block Parameters

Channel vector

Enter numbers between 1 and 8 to select the digital output lines used with this port. This driver allows the selection of individual digital output lines in arbitrary order. The number of elements defines the number of digital lines used.

For example, to use all of the digital outputs for one port, enter

```
[1,2,3,4,5,6,7,8]
```

Number the lines beginning with 1 even if this board manufacturer numbers the lines beginning with 0.

Port

From the list choose either A, B, or C. The I/O board has two 8255 chips with 3 ports. The **Port** parameter defines which port of the 8255 chip is used for this driver block. Each port has a maximum of 8 digital lines that can be configured as inputs or outputs depending on which driver block is chosen. In each case, one block is required for each port.

Reset vector

The reset vector controls the behavior of the channel at model termination. Enter a scalar or a vector that is the same length as the channel vector. If you specify a scalar value, that setting is replicated over the channel vector. If you specify a value of 1, the corresponding channel is reset to the value specified in the initial value vector. If you specify a value of 0, the channel remains at the last value attained while the model was running.

Initial value vector

The initial value vector contains the initial values (0 or 1) of the output channels. Enter a scalar or a vector that is the same length as the channel vector. If you enter a scalar, that value is replicated as the initial value over the channel vector. The channels are set to these initial values between the time the model is downloaded and the time it is started.

Chip

From the list choose 1 or 2. The **Chip** parameter defines which of the two 8255 chips is used.

Sample time

Enter the base sample time or a multiple of the base sample time (- 1 means sample time is inherited).

Base address

Enter the base address of the board. This entry must correspond to the DIP switch setting on the board. For example, if the DIP switch setting is 300 (hexadecimal), enter 0x300.

External Websites

- www.measurementcomputing.com

Measurement Computing PCI-DAC6703

Support for the MC PCI-DAC6703 I/O board

Board

Measurement Computing PCI-DAC6703

General Description

The PCI-DAC6703 is an I/O board with 16 analog output (D/A) channels (16-bit) and 8 digital input and output lines.

The Simulink Real-Time block library supports this board with these driver blocks:

- Measurement Computing PCI-DAC6703 Analog Output (D/A)
- Measurement Computing PCI-DAC6703 Digital Input
- Measurement Computing PCI-DAC6703 Digital Output

Board Characteristics

Board name	PCI-DAS6703
Manufacturer	Measurement Computing
Bus type	PCI
Access method	I/O mapped
Multiple block instance support	D/A: one block per board Digital I/O: each bit in at most one block
Multiple board support	Yes

External Websites

- www.measurementcomputing.com

Measurement Computing PCI-DAC6703 Analog Output (D/A)

PCI-DAC6703 Analog Output block

Library

Simulink Real-Time Library for Measurement Computing

Scaling Input to Output

I/O Module Output	Block Input Data Type	Scaling
Volts	Double	1

Block Parameters

Channel vector

Enter numbers between 1 and 16. This driver allows the selection of individual D/A in arbitrary order. The number of elements defines the number of analog output channels used. For example, to use all of the analog output channels, enter

[1,2,3,4,5,6,7,8,9,10,11,12,13,14,15,16]

Number the lines beginning with 1 even if this board manufacturer numbers the lines beginning with 0.

Reset vector

The reset vector controls the behavior of the channel at model termination. Enter a scalar or a vector that is the same length as the channel vector. If you specify a scalar value, that setting is replicated over the channel vector. If you specify a value of 1, the corresponding channel is reset to the value specified in the initial value vector. If you specify a value of 0, the channel remains at the last value attained while the model was running.

Initial value vector

The initial value vector contains the initial voltage values for the output channels. Enter a scalar or a vector that is the same length as the channel vector. If you specify a scalar value, that value is replicated as the initial value over the channel vector. The channels are set to the initial values between the time the model is downloaded and the time it is started.

Sample time

Enter the base sample time or a multiple of the base sample time (- 1 means sample time is inherited).

PCI slot (-1:autosearch)

If only one board of this type is in the target computer, enter - 1 to locate the board.

If two or more boards of this type are in the target computer, enter the bus number and the PCI slot number of the board associated with this driver block. Use the format **[BusNumber,SlotNumber]**.

To determine the bus number and the PCI slot number, type:

```
tg = slrt;  
getPCIInfo(tg, 'installed')
```

External Websites

- www.measurementcomputing.com

Measurement Computing PCI-DAC6703 Digital Input

PCI-DAC6703 Digital Input block

Library

Simulink Real-Time Library for Measurement Computing

Scaling Input to Output

I/O Module Input	Block Output Data Type	Scaling
TTL	Double	TTL low = 0.0 TTL high = 1.0

Block Parameters

Channel vector

Enter numbers between 1 and 8 to select the digital input lines. This driver allows the selection of individual digital input lines in arbitrary order. The number of elements defines the number of digital lines used.

For example, to use all of the digital inputs, enter

```
[1,2,3,4,5,6,7,8]
```

Each digital line can be in either a digital input or digital output block, but not both.

Number the lines beginning with 1 even if this board manufacturer numbers the lines beginning with 0.

Sample time

Enter the base sample time or a multiple of the base sample time (- 1 means sample time is inherited).

PCI slot (-1:autosearch)

If only one board of this type is in the target computer, enter - 1 to locate the board.

If two or more boards of this type are in the target computer, enter the bus number and the PCI slot number of the board associated with this driver block. Use the format **[BusNumber,SlotNumber]**.

To determine the bus number and the PCI slot number, type:

```
tg = slrt;  
getPCIInfo(tg, 'installed')
```

External Websites

- www.measurementcomputing.com

Measurement Computing PCI-DAC6703 Digital Output

PCI-DAC6703 Digital Output block

Library

Simulink Real-Time Library for Measurement Computing

Scaling Input to Output

I/O Module Output	Block Input Data Type	Scaling
TTL	Double	< 0.5 = TTL low ≥ 0.5 = TTL high

Block Parameters

Channel vector

Enter numbers between 1 and 8 to select the digital output lines used with this port. This driver allows the selection of individual digital output lines in arbitrary order. The number of elements defines the number of digital lines used.

For example, to use all of the digital outputs for one port, enter

```
[1,2,3,4,5,6,7,8]
```

Each digital line can be in either a digital input or digital output block, but not both.

Number the lines beginning with 1 even if this board manufacturer numbers the lines beginning with 0.

Reset vector

The reset vector controls the behavior of the channel at model termination. Enter a scalar or a vector that is the same length as the channel vector. If you specify a scalar value, that setting is replicated over the channel vector. If you specify a value of 1,

the corresponding channel is reset to the value specified in the initial value vector. If you specify a value of 0, the channel remains at the last value attained while the model was running.

Initial value vector

The initial value vector contains the initial values (0 or 1) of the output channels. Enter a scalar or a vector that is the same length as the channel vector. If you enter a scalar, that value is replicated as the initial value over the channel vector. The channels are set to these initial values between the time the model is downloaded and the time it is started.

Sample time

Enter the base sample time or a multiple of the base sample time (- 1 means sample time is inherited).

PCI slot (-1:autosearch)

If only one board of this type is in the target computer, enter - 1 to locate the board.

If two or more boards of this type are in the target computer, enter the bus number and the PCI slot number of the board associated with this driver block. Use the format **[BusNumber, SlotNumber]**.

To determine the bus number and the PCI slot number, type:

```
tg = slrt;  
getPCIInfo(tg, 'installed')
```

External Websites

- www.measurementcomputing.com

Measurement Computing PCI-DDA02/12

Support for the MC PCI-DDA02/12 I/O board

Board

Measurement Computing PCI-DDA02/12

General Description

The PCI-DDA02/12 is an I/O board with 2 analog output (D/A) channels (12-bit), and 48 digital I/O lines.

The Simulink Real-Time block library supports this board with these driver blocks:

- Measurement Computing PCI-DDA02/12 Analog Output (D/A)
- Measurement Computing PCI-DDA02/12 Digital Input
- Measurement Computing PCI-DDA02/12 Digital Output

Board Characteristics

Board name	PCI-DDA02/12
Manufacturer	Measurement Computing
Bus type	PCI
Access method	I/O mapped
Multiple block instance support	Yes
Multiple board support	Yes

External Websites

- www.measurementcomputing.com

Measurement Computing PCI-DDA02/12 Analog Output (D/A)

PCI-DDA02/12 Analog Output block

Library

Simulink Real-Time Library for Measurement Computing

Scaling Input to Output

I/O Module Output	Block Input Data Type	Scaling
Volts	Double	1

Block Parameters

Channel vector

Enter numbers 1 or 2. This driver allows the selection of individual D/A channels in arbitrary order. The number of elements defines the number of D/A channels used. For example, to use both of the analog output channels, enter

[1,2]

Number the channels beginning with 1 even if this board manufacturer starts numbering the channels with 0.

Range vector

Enter a range code for each of the channels in the channel vector. The range vector must be the same length as the channel vector. This board allows the range of each channel to be different.

The following table is a list of the ranges for this driver and the corresponding range codes.

Input Range (V)	Range Code
-10 to +10	-10

Input Range (V)	Range Code
-5 to +5	-5
-2.5 to +2.5	-2.5
0 to +10	10
0 to +5	5
0 to +2.5	2.5

For example, if the first channel is -10 to +10 volts and the second channel is 0 to +5 volts, enter

`[-10,5]`

The range settings must correspond to the DIP switch settings on the board. Also the bipolar/unipolar jumpers must be placed according to the ranges used.

Reset vector

The reset vector controls the behavior of the channel at model termination. Enter a scalar or a vector that is the same length as the channel vector. If you specify a scalar value, that setting is replicated over the channel vector. If you specify a value of 1, the corresponding channel is reset to the value specified in the initial value vector. If you specify a value of 0, the channel remains at the last value attained while the model was running.

Initial value vector

The initial value vector contains the initial voltage values for the output channels. Enter a scalar or a vector that is the same length as the channel vector. If you specify a scalar value, that value is replicated as the initial value over the channel vector. The channels are set to the initial values between the time the model is downloaded and the time it is started.

Sample time

Enter the base sample time or a multiple of the base sample time (-1 means sample time is inherited).

PCI slot (-1:autosearch)

If only one board of this type is in the target computer, enter -1 to locate the board.

If two or more boards of this type are in the target computer, enter the bus number and the PCI slot number of the board associated with this driver block. Use the format **[BusNumber,SlotNumber]**.

To determine the bus number and the PCI slot number, type:

```
tg = slrt;  
getPCIInfo(tg, 'installed')
```

External Websites

- www.measurementcomputing.com

Measurement Computing PCI-DDA02/12 Digital Input

PCI-DDA02/12 Digital Input

Library

Simulink Real-Time Library for Measurement Computing

Note

The PCI-DDA02/12 has two 8255 chips (1,2). Each chip has three ports (A,B,C). Each port has a maximum of 8 digital I/O lines that can be configured as inputs or outputs.

Use a separate driver block for each port. By selecting the digital input driver block, the port is configured as input.

Scaling Input to Output

I/O Module Input	Block Output Data Type	Scaling
TTL	Double	TTL low = 0.0 TTL high = 1.0

Block Parameters

Channel vector

Enter numbers between 1 and 8 to select the digital input lines used with this port. This driver allows the selection of individual digital input lines in arbitrary order. The number of elements defines the number of digital lines used.

For example, to use all of the digital inputs for one port, enter

```
[1,2,3,4,5,6,7,8]
```

Number the lines beginning with 1 even if this board manufacturer numbers the lines beginning with 0.

Port

From the list choose either **A**, **B**, or **C**. The I/O board has two 8255 chips with 3 ports. The **Port** parameter defines which port of the 8255 chip is used for this driver block. Each port has a maximum of 8 digital lines that can be configured as inputs or outputs depending on which driver block is chosen. In each case, one block is required for each port.

Chip

From the list choose **1** or **2**. The **Chip** parameter defines which of the two 8255 chips is used.

Sample time

Enter the base sample time or a multiple of the base sample time (- 1 means sample time is inherited).

PCI slot (-1:autosearch)

If only one board of this type is in the target computer, enter - 1 to locate the board.

If two or more boards of this type are in the target computer, enter the bus number and the PCI slot number of the board associated with this driver block. Use the format [**BusNumber**, **SlotNumber**].

To determine the bus number and the PCI slot number, type:

```
tg = slrt;  
getPCIInfo(tg, 'installed')
```

External Websites

- www.measurementcomputing.com

Measurement Computing PCI-DDA02/12 Digital Output

PCI-DDA02/12 Digital Output

Library

Simulink Real-Time Library for Measurement Computing

Note

The PCI-DDA02/12 has two 8255 chips (1,2). Each chip has three ports (A,B,C). Each port has a maximum of 8 digital I/O lines that can be configured as inputs or outputs.

Use a separate driver block for each port. By selecting the digital output driver block, the port is configured as output.

Scaling Input to Output

I/O Module Output	Block Input Data Type	Scaling
TTL	Double	$< 0.5 = \text{TTL low}$ $\geq 0.5 = \text{TTL high}$

Block Parameters

Channel vector

Enter numbers between 1 and 8 to select the digital output lines used with this port. This driver allows the selection of individual digital output lines in arbitrary order. The number of elements defines the number of digital lines used.

For example, to use all of the digital outputs for one port, enter

[1,2,3,4,5,6,7,8]

Number the lines beginning with 1 even if this board manufacturer numbers the lines beginning with 0.

Port

From the list choose either **A**, **B**, or **C**. The I/O board has two 8255 chips with 3 ports. The **Port** parameter defines which port of the 8255 chip is used for this driver block. Each port has a maximum of 8 digital lines that can be configured as inputs or outputs depending on which driver block is chosen. In each case, one block is required for each port.

Reset vector

The reset vector controls the behavior of the channel at model termination. Enter a scalar or a vector that is the same length as the channel vector. If you specify a scalar value, that setting is replicated over the channel vector. If you specify a value of 1, the corresponding channel is reset to the value specified in the initial value vector. If you specify a value of 0, the channel remains at the last value attained while the model was running.

Initial value vector

The initial value vector contains the initial values (0 or 1) of the output channels. Enter a scalar or a vector that is the same length as the channel vector. If you enter a scalar, that value is replicated as the initial value over the channel vector. The channels are set to these initial values between the time the model is downloaded and the time it is started.

Chip

From the list choose 1 or 2. The **Chip** parameter defines which of the two 8255 chips is used.

Sample time

Enter the base sample time or a multiple of the base sample time (-1 means sample time is inherited).

PCI slot (-1:autosearch)

If only one board of this type is in the target computer, enter -1 to locate the board.

If two or more boards of this type are in the target computer, enter the bus number and the PCI slot number of the board associated with this driver block. Use the format [**BusNumber**,**SlotNumber**].

To determine the bus number and the PCI slot number, type:

```
tg = slrt;
```



```
getPCIInfo(tg, 'installed')
```

External Websites

- www.measurementcomputing.com

Measurement Computing PCI-DDA02/16

Support for the MC PCI-DDA02/16 I/O board

Board

Measurement Computing PCI-DDA02/16

General Description

The PCI-DDA02/16 is an I/O board with 2 analog output (D/A) channels (12-bit), and 48 digital I/O lines.

The Simulink Real-Time block library supports this board with these driver blocks:

- Measurement Computing PCI-DDA02/16 Analog Output (D/A)
- Measurement Computing PCI-DDA02/16 Digital Input
- Measurement Computing PCI-DDA02/16 Digital Output

Board Characteristics

Board name	PCI-DDA06/12
Manufacturer	Measurement Computing
Bus type	PCI
Access method	I/O mapped
Multiple block instance support	Yes
Multiple board support	Yes

External Websites

- www.measurementcomputing.com

Measurement Computing PCI-DDA02/16 Analog Output (D/A)

PCI-DDA02/16 Analog Output block

Library

Simulink Real-Time Library for Measurement Computing

Scaling Input to Output

I/O Module Output	Block Input Data Type	Scaling
Volts	Double	1

Block Parameters

Channel vector

Enter 1 or 2. This driver allows the selection of individual D/A channels in arbitrary order. The number of elements defines the number of D/A channels used. For example, to use both of the analog output channels, enter

[1,2]

Number the channels beginning with 1 even if this board manufacturer starts numbering the channels with 0.

Range vector

Enter a range code for each of the channels in the channel vector. The range vector must be the same length as the channel vector. This board allows the range of each channel to be different.

The following table is a list of the ranges for this driver and the corresponding range codes.

Input Range (V)	Range Code
-10 to +10	-10

Input Range (V)	Range Code
-5 to +5	-5
-2.5 to +2.5	-2.5
0 to +10	10
0 to +5	5
0 to +2.5	2.5

For example, if the first channel is -10 to +10 volts and the second channel is 0 to +5 volts, enter

```
[-10,5]
```

The range settings must correspond to the DIP switch settings on the board. Also the bipolar/unipolar jumpers must be placed according to the ranges used.

Reset vector

The reset vector controls the behavior of the channel at model termination. Enter a scalar or a vector that is the same length as the channel vector. If you specify a scalar value, that setting is replicated over the channel vector. If you specify a value of 1, the corresponding channel is reset to the value specified in the initial value vector. If you specify a value of 0, the channel remains at the last value attained while the model was running.

Initial value vector

The initial value vector contains the initial voltage values for the output channels. Enter a scalar or a vector that is the same length as the channel vector. If you specify a scalar value, that value is replicated as the initial value over the channel vector. The channels are set to the initial values between the time the model is downloaded and the time it is started.

Sample time

Enter the base sample time or a multiple of the base sample time (-1 means sample time is inherited).

PCI slot (-1:autosearch)

If only one board of this type is in the target computer, enter -1 to locate the board.

If two or more boards of this type are in the target computer, enter the bus number and the PCI slot number of the board associated with this driver block. Use the format **[BusNumber,SlotNumber]**.

To determine the bus number and the PCI slot number, type:

```
tg = slrt;  
getPCIInfo(tg, 'installed')
```

External Websites

- www.measurementcomputing.com

Measurement Computing PCI-DDA02/16 Digital Input

PCI-DDA02/16 Digital Input

Library

Simulink Real-Time Library for Measurement Computing

Note

The PCI-DDA02/16 has two 8255 chips (1,2). Each chip has three ports (A,B,C). Each port has a maximum of 8 digital I/O lines that can be configured as inputs or outputs.

Use a separate driver block for each port. By selecting the digital input driver block, the port is configured as input.

Scaling Input to Output

I/O Module Input	Block Output Data Type	Scaling
TTL	Double	TTL low = 0.0 TTL high = 1.0

Block Parameters

Channel vector

Enter numbers between 1 and 8 to select the digital input lines used with this port. This driver allows the selection of individual digital input lines in arbitrary order. The number of elements defines the number of digital lines used.

For example, to use all of the digital inputs for one port, enter

```
[1,2,3,4,5,6,7,8]
```

Number the lines beginning with 1 even if this board manufacturer numbers the lines beginning with 0.

Port

From the list choose either **A**, **B**, or **C**. The I/O board has two 8255 chips with 3 ports. The **Port** parameter defines which port of the 8255 chip is used for this driver block. Each port has a maximum of 8 digital lines that can be configured as inputs or outputs depending on which driver block is chosen. In each case, one block is required for each port.

Chip

From the list choose **1** or **2**. The **Chip** parameter defines which of the two 8255 chips is used.

Sample time

Enter the base sample time or a multiple of the base sample time (- 1 means sample time is inherited).

PCI slot (-1:autosearch)

If only one board of this type is in the target computer, enter - 1 to locate the board.

If two or more boards of this type are in the target computer, enter the bus number and the PCI slot number of the board associated with this driver block. Use the format [**BusNumber**, **SlotNumber**].

To determine the bus number and the PCI slot number, type:

```
tg = slrt;  
getPCIInfo(tg, 'installed')
```

External Websites

- www.measurementcomputing.com

Measurement Computing PCI-DDA02/16 Digital Output

PCI-DDA02/16 Digital Output

Library

Simulink Real-Time Library for Measurement Computing

Note

The PCI-DDA02/16 has two 8255 chips (1,2). Each chip has three ports (A,B,C). Each port has a maximum of 8 digital I/O lines that can be configured as inputs or outputs.

Use a separate driver block for each port. By selecting the digital output driver block, the port is configured as output.

Scaling Input to Output

I/O Module Output	Block Input Data Type	Scaling
TTL	Double	< 0.5 = TTL low ≥ 0.5 = TTL high

Block Parameters

Channel vector

Enter numbers between 1 and 8 to select the digital output lines used with this port. This driver allows the selection of individual digital output lines in arbitrary order. The number of elements defines the number of digital lines used.

For example, to use all of the digital outputs for one port, enter

[1,2,3,4,5,6,7,8]

Number the lines beginning with 1 even if this board manufacturer numbers the lines beginning with 0.

Port

From the list choose either **A**, **B**, or **C**. The I/O board has two 8255 chips with 3 ports. The **Port** parameter defines which port of the 8255 chip is used for this driver block. Each port has a maximum of 8 digital lines that can be configured as inputs or outputs depending on which driver block is chosen. In each case, one block is required for each port.

Reset vector

The reset vector controls the behavior of the channel at model termination. Enter a scalar or a vector that is the same length as the channel vector. If you specify a scalar value, that setting is replicated over the channel vector. If you specify a value of 1, the corresponding channel is reset to the value specified in the initial value vector. If you specify a value of 0, the channel remains at the last value attained while the model was running.

Initial value vector

The initial value vector contains the initial values (0 or 1) of the output channels. Enter a scalar or a vector that is the same length as the channel vector. If you enter a scalar, that value is replicated as the initial value over the channel vector. The channels are set to these initial values between the time the model is downloaded and the time it is started.

Chip

From the list choose 1 or 2. The **Chip** parameter defines which of the two 8255 chips is used.

Sample time

Enter the base sample time or a multiple of the base sample time (-1 means sample time is inherited).

PCI slot (-1:autosearch)

If only one board of this type is in the target computer, enter -1 to locate the board.

If two or more boards of this type are in the target computer, enter the bus number and the PCI slot number of the board associated with this driver block. Use the format **[BusNumber, SlotNumber]**.

To determine the bus number and the PCI slot number, type:

```
tg = slrt;
```

```
getPCIInfo(tg, 'installed')
```

External Websites

- www.measurementcomputing.com

Measurement Computing PCI-DDA04/12

Support for the MC PCI-DDA04/12 I/O board

Board

Measurement Computing PCI-DDA04/12

General Description

The PCI-DDA04/12 is an I/O board with 4 analog output (D/A) channels (12-bit), and 48 digital I/O lines.

The Simulink Real-Time block library supports this board with these driver blocks:

- Measurement Computing PCI-DDA04/12 Analog Output (D/A)
- Measurement Computing PCI-DDA04/12 Digital Input
- Measurement Computing PCI-DDA04/12 Digital Output

Board Characteristics

Board name	PCI-DDA04/12
Manufacturer	Measurement Computing
Bus type	PCI
Access method	I/O mapped
Multiple block instance support	Yes
Multiple board support	Yes

External Websites

- www.measurementcomputing.com

Measurement Computing PCI-DDA04/12 Analog Output (D/A)

PCI-DDA04/12 Analog Output block

Library

Simulink Real-Time Library for Measurement Computing

Scaling Input to Output

I/O Module Output	Block Input Data Type	Scaling
Volts	Double	1

Block Parameters

Channel vector

Enter numbers between 1 and 4. This driver allows the selection of individual D/A channels in arbitrary order. The number of elements defines the number of D/A channels used. For example, to use the first and second analog output channels, enter

[1,2]

Number the channels beginning with 1 even if this board manufacturer starts numbering the channels with 0.

Range vector

Enter a range code for each of the channels in the channel vector. The range vector must be the same length as the channel vector. This board allows the range of each channel to be different.

The following table is a list of the ranges for this driver and the corresponding range codes.

Input Range (V)	Range Code
-10 to +10	-10

Input Range (V)	Range Code
-5 to +5	-5
-2.5 to +2.5	-2.5
0 to +10	10
0 to +5	5
0 to +2.5	2.5

For example, if the first channel is -10 to +10 volts and the second channel is 0 to +5 volts, enter

[-10,5]

The range settings must correspond to the DIP switch settings on the board. Also the bipolar/unipolar jumpers must be placed according to the ranges used.

Reset vector

The reset vector controls the behavior of the channel at model termination. Enter a scalar or a vector that is the same length as the channel vector. If you specify a scalar value, that setting is replicated over the channel vector. If you specify a value of 1, the corresponding channel is reset to the value specified in the initial value vector. If you specify a value of 0, the channel remains at the last value attained while the model was running.

Initial value vector

The initial value vector contains the initial voltage values for the output channels. Enter a scalar or a vector that is the same length as the channel vector. If you specify a scalar value, that value is replicated as the initial value over the channel vector. The channels are set to the initial values between the time the model is downloaded and the time it is started.

Sample time

Enter the base sample time or a multiple of the base sample time (-1 means sample time is inherited).

PCI slot (-1:autosearch)

If only one board of this type is in the target computer, enter -1 to locate the board.

If two or more boards of this type are in the target computer, enter the bus number and the PCI slot number of the board associated with this driver block. Use the format **[BusNumber,SlotNumber]**.

To determine the bus number and the PCI slot number, type:

```
tg = slrt;  
getPCIInfo(tg, 'installed')
```

External Websites

- www.measurementcomputing.com

Measurement Computing PCI-DDA04/12 Digital Input

PCI-DDA04/12 Digital Input

Library

Simulink Real-Time Library for Measurement Computing

Note

The PCI-DDA4/12 has two 8255 chips (1,2). Each chip has three ports (A,B,C). Each port has a maximum of 8 digital I/O lines that can be configured as inputs or outputs.

Use a separate driver block for each port. By selecting the digital input driver block, the port is configured as input.

Scaling Input to Output

I/O Module Input	Block Output Data Type	Scaling
TTL	Double	TTL low = 0.0 TTL high = 1.0

Block Parameters

Channel vector

Enter numbers between 1 and 8 to select the digital input lines used with this port. This driver allows the selection of individual digital input lines in arbitrary order. The number of elements defines the number of digital lines used.

For example, to use all of the digital inputs for one port, enter

```
[1,2,3,4,5,6,7,8]
```

Number the lines beginning with 1 even if this board manufacturer numbers the lines beginning with 0.

Port

From the list choose either **A**, **B**, or **C**. The I/O board has two 8255 chips with 3 ports. The **Port** parameter defines which port of the 8255 chip is used for this driver block. Each port has a maximum of 8 digital lines that can be configured as inputs or outputs depending on which driver block is chosen. In each case, one block is required for each port.

Chip

From the list choose **1** or **2**. The **Chip** parameter defines which of the two 8255 chips is used.

Sample time

Enter the base sample time or a multiple of the base sample time (- 1 means sample time is inherited).

PCI slot (-1:autosearch)

If only one board of this type is in the target computer, enter - 1 to locate the board.

If two or more boards of this type are in the target computer, enter the bus number and the PCI slot number of the board associated with this driver block. Use the format [**BusNumber**, **SlotNumber**].

To determine the bus number and the PCI slot number, type:

```
tg = slrt;  
getPCIInfo(tg, 'installed')
```

External Websites

- www.measurementcomputing.com

Measurement Computing PCI-DDA04/12 Digital Output

PCI-DDA04/12 Digital Output

Library

Simulink Real-Time Library for Measurement Computing

Note

The PCI-DDA04/12 has two 8255 chips (1,2). Each chip has three ports (A,B,C). Each port has a maximum of 8 digital I/O lines that can be configured as inputs or outputs.

Use a separate driver block for each port. By selecting the digital output driver block, the port is configured as output.

Scaling Input to Output

I/O Module Output	Block Input Data Type	Scaling
TTL	Double	$< 0.5 = \text{TTL low}$ $\geq 0.5 = \text{TTL high}$

Block Parameters

Channel vector

Enter numbers between 1 and 8 to select the digital output lines used with this port. This driver allows the selection of individual digital output lines in arbitrary order. The number of elements defines the number of digital lines used.

For example, to use all of the digital outputs for one port, enter

[1,2,3,4,5,6,7,8]

Number the lines beginning with 1 even if this board manufacturer numbers the lines beginning with 0.

Port

From the list choose either **A**, **B**, or **C**. The I/O board has two 8255 chips with 3 ports. The **Port** parameter defines which port of the 8255 chip is used for this driver block. Each port has a maximum of 8 digital lines that can be configured as inputs or outputs depending on which driver block is chosen. In each case, one block is required for each port.

Reset vector

The reset vector controls the behavior of the channel at model termination. Enter a scalar or a vector that is the same length as the channel vector. If you specify a scalar value, that setting is replicated over the channel vector. If you specify a value of 1, the corresponding channel is reset to the value specified in the initial value vector. If you specify a value of 0, the channel remains at the last value attained while the model was running.

Initial value vector

The initial value vector contains the initial values (0 or 1) of the output channels. Enter a scalar or a vector that is the same length as the channel vector. If you enter a scalar, that value is replicated as the initial value over the channel vector. The channels are set to these initial values between the time the model is downloaded and the time it is started.

Chip

From the list choose 1 or 2. The **Chip** parameter defines which of the two 8255 chips is used.

Sample time

Enter the base sample time or a multiple of the base sample time (-1 means sample time is inherited).

PCI slot (-1:autosearch)

If only one board of this type is in the target computer, enter -1 to locate the board.

If two or more boards of this type are in the target computer, enter the bus number and the PCI slot number of the board associated with this driver block. Use the format [**BusNumber**,**SlotNumber**].

To determine the bus number and the PCI slot number, type:

```
tg = slrt;
```

```
getPCIInfo(tg, 'installed')
```

External Websites

- www.measurementcomputing.com

Measurement Computing PCI-DDA04/16

Support for the MC PCI-DDA04/16 I/O board

Board

Measurement Computing PCI-DDA04/16

General Description

The PCI-DDA04/16 is an I/O board with 4 analog output (D/A) channels (16-bit), and 48 digital I/O lines.

The Simulink Real-Time block library supports this board with these driver blocks:

- Measurement Computing PCI-DDA04/16 Analog Output (D/A)
- Measurement Computing PCI-DDA04/16 Digital Input
- Measurement Computing PCI-DDA04/16 Digital Output

Board Characteristics

Board name	PCI-DDA04/16
Manufacturer	Measurement Computing
Bus type	PCI
Access method	I/O mapped
Multiple block instance support	Yes
Multiple board support	Yes

External Websites

- www.measurementcomputing.com

Measurement Computing PCI-DDA04/16 Analog Output (D/A)

PCI-DDA04/16 Analog Output block

Library

Simulink Real-Time Library for Measurement Computing

Scaling Input to Output

I/O Module Output	Block Input Data Type	Scaling
Volts	Double	1

Block Parameters

Channel vector

Enter numbers between 1 and 4. This driver allows the selection of individual D/A channels in arbitrary order. The number of elements defines the number of D/A channels used. For example, to use the first and second analog output channels, enter

[1,2]

Number the channels beginning with 1 even if this board manufacturer starts numbering the channels with 0.

Range vector

Enter a range code for each of the channels in the channel vector. The range vector must be the same length as the channel vector. This board allows the range of each channel to be different.

The following table is a list of the ranges for this driver and the corresponding range codes.

Input Range (V)	Range Code
-10 to +10	-10

Input Range (V)	Range Code
-5 to +5	-5
-2.5 to +2.5	-2.5
0 to +10	10
0 to +5	5
0 to +2.5	2.5

For example, if the first channel is -10 to +10 volts and the second channel is 0 to +5 volts, enter

```
[-10,5]
```

The range settings must correspond to the DIP switch settings on the board. Also the bipolar/unipolar jumpers must be placed according to the ranges used.

Reset vector

The reset vector controls the behavior of the channel at model termination. Enter a scalar or a vector that is the same length as the channel vector. If you specify a scalar value, that setting is replicated over the channel vector. If you specify a value of 1, the corresponding channel is reset to the value specified in the initial value vector. If you specify a value of 0, the channel remains at the last value attained while the model was running.

Initial value vector

The initial value vector contains the initial voltage values for the output channels. Enter a scalar or a vector that is the same length as the channel vector. If you specify a scalar value, that value is replicated as the initial value over the channel vector. The channels are set to the initial values between the time the model is downloaded and the time it is started.

Sample time

Enter the base sample time or a multiple of the base sample time (-1 means sample time is inherited).

PCI slot (-1:autosearch)

If only one board of this type is in the target computer, enter -1 to locate the board.

If two or more boards of this type are in the target computer, enter the bus number and the PCI slot number of the board associated with this driver block. Use the format **[BusNumber,SlotNumber]**.

To determine the bus number and the PCI slot number, type:

```
tg = slrt;  
getPCIInfo(tg, 'installed')
```

External Websites

- www.measurementcomputing.com

Measurement Computing PCI-DDA04/16 Digital Input

PCI-DDA04/16 Digital Input block

Library

Simulink Real-Time Library for Measurement Computing

Note

The PCI-DDA4/16 has two 8255 chips (1,2). Each chip has three ports (A,B,C). Each port has a maximum of 8 digital I/O lines that can be configured as inputs or outputs.

Use a separate driver block for each port. By selecting the digital input driver block, the port is configured as input.

Scaling Input to Output

I/O Module Input	Block Output Data Type	Scaling
TTL	Double	TTL low = 0.0 TTL high = 1.0

Block Parameters

Channel vector

Enter numbers between 1 and 8 to select the digital input lines used with this port. This driver allows the selection of individual digital input lines in arbitrary order. The number of elements defines the number of digital lines used.

For example, to use all of the digital inputs for one port, enter

[1,2,3,4,5,6,7,8]

Number the lines beginning with 1 even if this board manufacturer numbers the lines beginning with 0.

Port

From the list choose either **A**, **B**, or **C**. The I/O board has two 8255 chips with 3 ports. The **Port** parameter defines which port of the 8255 chip is used for this driver block. Each port has a maximum of 8 digital lines that can be configured as inputs or outputs depending on which driver block is chosen. In each case, one block is required for each port.

Chip

From the list choose **1** or **2**. The **Chip** parameter defines which of the two 8255 chips is used.

Sample time

Enter the base sample time or a multiple of the base sample time (- 1 means sample time is inherited).

PCI slot (-1:autosearch)

If only one board of this type is in the target computer, enter - 1 to locate the board.

If two or more boards of this type are in the target computer, enter the bus number and the PCI slot number of the board associated with this driver block. Use the format [**BusNumber**, **SlotNumber**].

To determine the bus number and the PCI slot number, type:

```
tg = slrt;  
getPCIInfo(tg, 'installed')
```

External Websites

- www.measurementcomputing.com

Measurement Computing PCI-DDA04/16 Digital Output

PCI-DDA04/16 Digital Output

Library

Simulink Real-Time Library for Measurement Computing

Note

The PCI-DDA04/16 has two 8255 chips (1,2). Each chip has three ports (A,B,C). Each port has a maximum of 8 digital I/O lines that can be configured as inputs or outputs.

Use a separate driver block for each port. By selecting the digital output driver block, the port is configured as output.

Scaling Input to Output

I/O Module Output	Block Input Data Type	Scaling
TTL	Double	$< 0.5 = \text{TTL low}$ $\geq 0.5 = \text{TTL high}$

Block Parameters

Channel vector

Enter numbers between 1 and 8 to select the digital output lines used with this port. This driver allows the selection of individual digital output lines in arbitrary order. The number of elements defines the number of digital lines used.

For example, to use all of the digital outputs for one port, enter

[1,2,3,4,5,6,7,8]

Number the lines beginning with 1 even if this board manufacturer numbers the lines beginning with 0.

Port

From the list choose either **A**, **B**, or **C**. The I/O board has two 8255 chips with 3 ports. The **Port** parameter defines which port of the 8255 chip is used for this driver block. Each port has a maximum of 8 digital lines that can be configured as inputs or outputs depending on which driver block is chosen. In each case, one block is required for each port.

Reset vector

The reset vector controls the behavior of the channel at model termination. Enter a scalar or a vector that is the same length as the channel vector. If you specify a scalar value, that setting is replicated over the channel vector. If you specify a value of 1, the corresponding channel is reset to the value specified in the initial value vector. If you specify a value of 0, the channel remains at the last value attained while the model was running.

Initial value vector

The initial value vector contains the initial values (0 or 1) of the output channels. Enter a scalar or a vector that is the same length as the channel vector. If you enter a scalar, that value is replicated as the initial value over the channel vector. The channels are set to these initial values between the time the model is downloaded and the time it is started.

Chip

From the list choose 1 or 2. The **Chip** parameter defines which of the two 8255 chips is used.

Sample time

Enter the base sample time or a multiple of the base sample time (- 1 means sample time is inherited).

PCI slot (-1:autosearch)

If only one board of this type is in the target computer, enter - 1 to locate the board.

If two or more boards of this type are in the target computer, enter the bus number and the PCI slot number of the board associated with this driver block. Use the format [**BusNumber**,**SlotNumber**].

To determine the bus number and the PCI slot number, type:

```
tg = slrt;
```

```
getPCIInfo(tg, 'installed')
```

External Websites

- www.measurementcomputing.com

Measurement Computing PCI-DDA08/12

Support for the MC PCI-DDA08/12 I/O board

Board

Measurement Computing PCI-DDA08/12

General Description

The PCI-DDA08/12 is an I/O board with 8 analog output (A/D) channels (16-bit), and 48 digital I/O lines.

The Simulink Real-Time block library supports this board with these driver blocks:

- Measurement Computing PCI-DDA08/12 Analog Output (D/A)
- Measurement Computing PCI-DDA08/12 Digital Input
- Measurement Computing PCI-DDA08/12 Digital Output

Board Characteristics

Board name	PCI-DDA08/12
Manufacturer	Measurement Computing
Bus type	PCI
Access method	I/O mapped
Multiple block instance support	Yes
Multiple board support	Yes

External Websites

- www.measurementcomputing.com

Measurement Computing PCI-DDA08/12 Analog Output (D/A)

PCI-DDA08/12 Analog Output block

Library

Simulink Real-Time Library for Measurement Computing

Scaling Input to Output

I/O Module Output	Block Input Data Type	Scaling
Volts	Double	1

Block Parameters

Channel vector

Enter numbers between 1 and 8. This driver allows the selection of individual D/A channels in arbitrary order. The number of elements defines the number of D/A channels used. For example, to use the first and second analog output channels, enter

[1,2]

Number the channels beginning with 1 even if this board manufacturer starts numbering the channels with 0.

Range vector

Enter a range code for each of the channels in the channel vector. The range vector must be the same length as the channel vector. This board allows the range of each channel to be different.

The following table is a list of the ranges for this driver and the corresponding range codes

Input Range (V)	Range Code
-10 to +10	-10

Input Range (V)	Range Code
-5 to +5	-5
-2.5 to +2.5	-2.5
0 to +10	10
0 to +5	5
0 to +2.5	2.5

For example, if the first channel is -10 to +10 volts and the second channel is 0 to +5 volts, enter

[-10,5]

The range settings must correspond to the DIP switch settings on the board. Also the bipolar/unipolar jumpers must be placed according to the ranges used.

Reset vector

The reset vector controls the behavior of the channel at model termination. Enter a scalar or a vector that is the same length as the channel vector. If you specify a scalar value, that setting is replicated over the channel vector. If you specify a value of 1, the corresponding channel is reset to the value specified in the initial value vector. If you specify a value of 0, the channel remains at the last value attained while the model was running.

Initial value vector

The initial value vector contains the initial voltage values for the output channels. Enter a scalar or a vector that is the same length as the channel vector. If you specify a scalar value, that value is replicated as the initial value over the channel vector. The channels are set to the initial values between the time the model is downloaded and the time it is started.

Sample time

Enter the base sample time or a multiple of the base sample time (-1 means sample time is inherited).

PCI slot (-1:autosearch)

If only one board of this type is in the target computer, enter -1 to locate the board.

If two or more boards of this type are in the target computer, enter the bus number and the PCI slot number of the board associated with this driver block. Use the format **[BusNumber,SlotNumber]**.

To determine the bus number and the PCI slot number, type:

```
tg = slrt;  
getPCIInfo(tg, 'installed')
```

External Websites

- www.measurementcomputing.com

Measurement Computing PCI-DDA08/12 Digital Input

PCI-DDA08/12 Digital Input block

Library

Simulink Real-Time Library for Measurement Computing

Note

The PCI-DDA08/12 has two 8255 chips (1,2). Each chip has three ports (A,B,C). Each port has a maximum of 8 digital I/O lines that can be configured as inputs or outputs.

Use a separate driver block for each port. By selecting the digital input driver block, the port is configured as input.

Scaling Input to Output

I/O Module Input	Block Output Data Type	Scaling
TTL	Double	TTL low = 0.0 TTL high = 1.0

Block Parameters

Channel vector

Enter numbers between 1 and 8 to select the digital input lines used with this port. This driver allows the selection of individual digital input lines in arbitrary order. The number of elements defines the number of digital lines used.

For example, to use all of the digital inputs for one port, enter

```
[1,2,3,4,5,6,7,8]
```

Number the lines beginning with 1 even if this board manufacturer numbers the lines beginning with 0.

Port

From the list choose either **A**, **B**, or **C**. The I/O board has two 8255 chips with 3 ports. The **Port** parameter defines which port of the 8255 chip is used for this driver block. Each port has a maximum of 8 digital lines that can be configured as inputs or outputs depending on which driver block is chosen. In each case, one block is required for each port.

Chip

From the list choose **1** or **2**. The **Chip** parameter defines which of the two 8255 chips is used.

Sample time

Enter the base sample time or a multiple of the base sample time (- 1 means sample time is inherited).

PCI slot (-1:autosearch)

If only one board of this type is in the target computer, enter - 1 to locate the board.

If two or more boards of this type are in the target computer, enter the bus number and the PCI slot number of the board associated with this driver block. Use the format [**BusNumber**, **SlotNumber**].

To determine the bus number and the PCI slot number, type:

```
tg = slrt;  
getPCIInfo(tg, 'installed')
```

External Websites

- www.measurementcomputing.com

Measurement Computing PCI-DDA08/12 Digital Output

PCI-DDA08/12 Digital Output block

Library

Simulink Real-Time Library for Measurement Computing

Note

The PCI-DDA08/12 has two 8255 chips (1,2). Each chip has three ports (A,B,C). Each port has a maximum of 8 digital I/O lines that can be configured as inputs or outputs.

Use a separate driver block for each port. By selecting the digital output driver block, the port is configured as output.

Scaling Input to Output

I/O Module Output	Block Input Data Type	Scaling
TTL	Double	$< 0.5 = \text{TTL low}$ $\geq 0.5 = \text{TTL high}$

Block Parameters

Channel vector

Enter numbers between 1 and 8 to select the digital output lines used with this port. This driver allows the selection of individual digital output lines in arbitrary order. The number of elements defines the number of digital lines used.

For example, to use all of the digital outputs for one port, enter

[1,2,3,4,5,6,7,8]

Number the lines beginning with 1 even if this board manufacturer numbers the lines beginning with 0.

Port

From the list choose either **A**, **B**, or **C**. The I/O board has two 8255 chips with 3 ports. The **Port** parameter defines which port of the 8255 chip is used for this driver block. Each port has a maximum of 8 digital lines that can be configured as inputs or outputs depending on which driver block is chosen. In each case, one block is required for each port.

Reset vector

The reset vector controls the behavior of the channel at model termination. Enter a scalar or a vector that is the same length as the channel vector. If you specify a scalar value, that setting is replicated over the channel vector. If you specify a value of 1, the corresponding channel is reset to the value specified in the initial value vector. If you specify a value of 0, the channel remains at the last value attained while the model was running.

Initial value vector

The initial value vector contains the initial values (0 or 1) of the output channels. Enter a scalar or a vector that is the same length as the channel vector. If you enter a scalar, that value is replicated as the initial value over the channel vector. The channels are set to these initial values between the time the model is downloaded and the time it is started.

Chip

From the list choose 1 or 2. The **Chip** parameter defines which of the two 8255 chips is used.

Sample time

Enter the base sample time or a multiple of the base sample time (-1 means sample time is inherited).

PCI slot (-1:autosearch)

If only one board of this type is in the target computer, enter -1 to locate the board.

If two or more boards of this type are in the target computer, enter the bus number and the PCI slot number of the board associated with this driver block. Use the format [**BusNumber**,**SlotNumber**].

To determine the bus number and the PCI slot number, type:

```
tg = slrt;
```

```
getPCIInfo(tg, 'installed')
```

External Websites

- www.measurementcomputing.com

Measurement Computing PCI-DDA08/16

Support for the MC PCI-DDA08/16 I/O board

Board

Measurement Computing PCI-DDA08/16

General Description

The PCI-DDA08/16 is an I/O board with 8 analog output (A/D) channels (12-bit), and 48 digital I/O lines.

The Simulink Real-Time block library supports this board with these driver blocks:

- Measurement Computing PCI-DDA08/16 Analog Output (D/A)
- Measurement Computing PCI-DDA08/16 Digital Input
- Measurement Computing PCI-DDA08/16 Digital Output

Board Characteristics

Board name	PCI-DDA06/12
Manufacturer	Measurement Computing
Bus type	PCI
Access method	I/O mapped
Multiple block instance support	Yes
Multiple board support	Yes

External Websites

- www.measurementcomputing.com

Measurement Computing PCI-DDA08/16 Analog Output (D/A)

PCI-DDA08/16 Analog Output block

Library

Simulink Real-Time Library for Measurement Computing

Scaling Input to Output

I/O Module Output	Block Input Data Type	Scaling
Volts	Double	1

Block Parameters

Channel vector

Enter numbers between 1 and 8. This driver allows the selection of individual D/A channels in arbitrary order. The number of elements defines the number of D/A channels used. For example, to use the first and second analog output channels, enter

[1,2]

Number the channels beginning with 1 even if this board manufacturer starts numbering the channels with 0.

Range vector

Enter a range code for each of the channels in the channel vector. The range vector must be the same length as the channel vector. This board allows the range of each channel to be different.

The following table is a list of the ranges for this driver and the corresponding range codes

Input Range (V)	Range Code
-10 to +10	-10

Input Range (V)	Range Code
-5 to +5	-5
-2.5 to +2.5	-2.5
0 to +10	10
0 to +5	5
0 to +2.5	2.5

For example, if the first channel is -10 to +10 volts and the second channel is 0 to +5 volts, enter

```
[-10,5]
```

The range settings must correspond to the DIP switch settings on the board. Also the bipolar/unipolar jumpers must be placed according to the ranges used.

Reset vector

The reset vector controls the behavior of the channel at model termination. Enter a scalar or a vector that is the same length as the channel vector. If you specify a scalar value, that setting is replicated over the channel vector. If you specify a value of 1, the corresponding channel is reset to the value specified in the initial value vector. If you specify a value of 0, the channel remains at the last value attained while the model was running.

Initial value vector

The initial value vector contains the initial voltage values for the output channels. Enter a scalar or a vector that is the same length as the channel vector. If you specify a scalar value, that value is replicated as the initial value over the channel vector. The channels are set to the initial values between the time the model is downloaded and the time it is started.

Sample time

Enter the base sample time or a multiple of the base sample time (-1 means sample time is inherited).

PCI slot (-1:autosearch)

If only one board of this type is in the target computer, enter -1 to locate the board.

If two or more boards of this type are in the target computer, enter the bus number and the PCI slot number of the board associated with this driver block. Use the format **[BusNumber,SlotNumber]**.

To determine the bus number and the PCI slot number, type:

```
tg = slrt;  
getPCIInfo(tg, 'installed')
```

External Websites

- www.measurementcomputing.com

Measurement Computing PCI-DDA08/16 Digital Input

PCI-DDA08/16 Digital Input

Library

Simulink Real-Time Library for Measurement Computing

Note

The PCI-DDA08/16 has two 8255 chips (1,2). Each chip has three ports (A,B,C). Each port has a maximum of 8 digital I/O lines that can be configured as inputs or outputs.

Use a separate driver block for each port. By selecting the digital input driver block, the port is configured as input.

Scaling Input to Output

I/O Module Input	Block Output Data Type	Scaling
TTL	Double	TTL low = 0.0 TTL high = 1.0

Block Parameters

Channel vector

Enter numbers between 1 and 8 to select the digital input lines used with this port. This driver allows the selection of individual digital input lines in arbitrary order. The number of elements defines the number of digital lines used.

For example, to use all of the digital inputs for one port, enter

```
[1,2,3,4,5,6,7,8]
```

Number the lines beginning with 1 even if this board manufacturer numbers the lines beginning with 0.

Port

From the list choose either **A**, **B**, or **C**. The I/O board has two 8255 chips with 3 ports. The **Port** parameter defines which port of the 8255 chip is used for this driver block. Each port has a maximum of 8 digital lines that can be configured as inputs or outputs depending on which driver block is chosen. In each case, one block is required for each port.

Chip

From the list choose **1** or **2**. The **Chip** parameter defines which of the two 8255 chips is used.

Sample time

Enter the base sample time or a multiple of the base sample time (- 1 means sample time is inherited).

PCI slot (-1:autosearch)

If only one board of this type is in the target computer, enter - 1 to locate the board.

If two or more boards of this type are in the target computer, enter the bus number and the PCI slot number of the board associated with this driver block. Use the format [**BusNumber**, **SlotNumber**].

To determine the bus number and the PCI slot number, type:

```
tg = slrt;  
getPCIInfo(tg, 'installed')
```

External Websites

- www.measurementcomputing.com

Measurement Computing PCI-DDA08/16 Digital Output

PCI-DDA08/16 Digital Output

Library

Simulink Real-Time Library for Measurement Computing

Note

The PCI-DDA08/16 has two 8255 chips (1,2). Each chip has three ports (A,B,C). Each port has a maximum of 8 digital I/O lines that can be configured as inputs or outputs.

Use a separate driver block for each port. By selecting the digital output driver block, the port is configured as output.

Scaling Input to Output

I/O Module Output	Block Input Data Type	Scaling
TTL	Double	$< 0.5 = \text{TTL low}$ $\geq 0.5 = \text{TTL high}$

Block Parameters

Channel vector

Enter numbers between 1 and 8 to select the digital output lines used with this port. This driver allows the selection of individual digital output lines in arbitrary order. The number of elements defines the number of digital lines used.

For example, to use all of the digital outputs for one port, enter

[1,2,3,4,5,6,7,8]

Number the lines beginning with 1 even if this board manufacturer numbers the lines beginning with 0.

Port

From the list choose either **A**, **B**, or **C**. The I/O board has two 8255 chips with 3 ports. The **Port** parameter defines which port of the 8255 chip is used for this driver block. Each port has a maximum of 8 digital lines that can be configured as inputs or outputs depending on which driver block is chosen. In each case, one block is required for each port.

Reset vector

The reset vector controls the behavior of the channel at model termination. Enter a scalar or a vector that is the same length as the channel vector. If you specify a scalar value, that setting is replicated over the channel vector. If you specify a value of 1, the corresponding channel is reset to the value specified in the initial value vector. If you specify a value of 0, the channel remains at the last value attained while the model was running.

Initial value vector

The initial value vector contains the initial values (0 or 1) of the output channels. Enter a scalar or a vector that is the same length as the channel vector. If you enter a scalar, that value is replicated as the initial value over the channel vector. The channels are set to these initial values between the time the model is downloaded and the time it is started.

Chip

From the list choose 1 or 2. The **Chip** parameter defines which of the two 8255 chips is used.

Sample time

Enter the base sample time or a multiple of the base sample time (- 1 means sample time is inherited).

PCI slot (-1:autosearch)

If only one board of this type is in the target computer, enter - 1 to locate the board.

If two or more boards of this type are in the target computer, enter the bus number and the PCI slot number of the board associated with this driver block. Use the format [**BusNumber**,**SlotNumber**].

To determine the bus number and the PCI slot number, type:

```
tg = slrt;
```

```
getPCIInfo(tg, 'installed')
```

External Websites

- www.measurementcomputing.com

Measurement Computing PCI-DIO24

Support for the MC PCI-DIO24 I/O board

Board

Measurement Computing PCI-DIO24

General Description

The PCI-DIO24 is an I/O board with 24 digital I/O lines.

The Simulink Real-Time block library supports this board with these driver blocks:

- Measurement Computing PCI-DIO24 Digital Input
- Measurement Computing PCI-DIO24 Digital Output

Board Characteristics

Board name	PCI-DIO24
Manufacturer	Measurement Computing
Bus type	PCI
Access method	I/O mapped
Multiple block instance support	Yes
Multiple board support	Yes

External Websites

- www.measurementcomputing.com

Measurement Computing PCI-DIO24 Digital Input

PCI-DIO24 Digital Input

Library

Simulink Real-Time Library for Measurement Computing

Note

The PCI-DIO24 has one 8255 chip with 3 ports (A,B,C). Each port has a maximum of 8 digital I/O lines that can be configured as inputs or outputs.

Use a separate driver block for each port. By selecting the digital input driver block, the port is configured as input.

Scaling Input to Output

I/O Module Input	Block Output Data Type	Scaling
TTL	Double	TTL low = 0.0 TTL high = 1.0

Block Parameters

Channel vector

Enter numbers between 1 and 8 to select the digital input lines used with this port. This driver allows the selection of individual digital input lines in arbitrary order. The number of elements defines the number of digital lines used.

For example, to use all of the digital inputs for one port, enter

```
[1,2,3,4,5,6,7,8]
```

Number the lines beginning with 1 even if this board manufacturer numbers the lines beginning with 0.

Port

From the list choose either **A**, **B**, or **C**. The I/O board has an 8255 chip with 3 ports. The **Port** parameter defines which port of the 8255 chip is used for this driver block. Each port has a maximum of 8 digital lines that can be configured as inputs or outputs depending on which driver block is chosen. In each case, one block is required for each port.

Sample time

Enter the base sample time or a multiple of the base sample time (- 1 means sample time is inherited).

PCI slot (-1:autosearch)

If only one board of this type is in the target computer, enter -1 to locate the board.

If two or more boards of this type are in the target computer, enter the bus number and the PCI slot number of the board associated with this driver block. Use the format [**BusNumber**,**SlotNumber**].

To determine the bus number and the PCI slot number, type:

```
tg = slrt;  
getPCIInfo(tg, 'installed')
```

External Websites

- www.measurementcomputing.com

Measurement Computing PCI-DIO24 Digital Output

PCI-DIO24 Digital Output

Library

Simulink Real-Time Library for Measurement Computing

Note

The PCI-DIO24 has one 8255 chip with 3 ports (A,B,C). Each port has a maximum of 8 digital I/O lines that can be configured as inputs or outputs.

Use a separate driver block for each port. By selecting the digital output driver block, the port is configured as output.

Scaling Input to Output

I/O Module Output	Block Input Data Type	Scaling
TTL	Double	$< 0.5 = \text{TTL low}$ $\geq 0.5 = \text{TTL high}$

Block Parameters

Channel vector

Enter numbers between 1 and 8 to select the digital output lines used with this port. This driver allows the selection of individual digital output lines in arbitrary order. The number of elements defines the number of digital lines used.

For example, to use all of the digital outputs for one port, enter

```
[1,2,3,4,5,6,7,8]
```

Number the lines beginning with 1 even if this board manufacturer numbers the lines beginning with 0.

Port

From the list choose either **A**, **B**, or **C**. The I/O board has an 8255 chip with 3 ports. The **Port** parameter defines which port of the 8255 chip is used for this driver block. Each port has a maximum of 8 digital lines that can be configured as inputs or outputs depending on which driver block is chosen. In each case, one block is required for each port.

Reset vector

The reset vector controls the behavior of the channel at model termination. Enter a scalar or a vector that is the same length as the channel vector. If you specify a scalar value, that setting is replicated over the channel vector. If you specify a value of 1, the corresponding channel is reset to the value specified in the initial value vector. If you specify a value of 0, the channel remains at the last value attained while the model was running.

Initial value vector

The initial value vector contains the initial values (0 or 1) of the output channels. Enter a scalar or a vector that is the same length as the channel vector. If you enter a scalar, that value is replicated as the initial value over the channel vector. The channels are set to these initial values between the time the model is downloaded and the time it is started.

Sample time

Enter the base sample time or a multiple of the base sample time (- 1 means sample time is inherited).

PCI slot (-1:autosearch)

If only one board of this type is in the target computer, enter - 1 to locate the board.

If two or more boards of this type are in the target computer, enter the bus number and the PCI slot number of the board associated with this driver block. Use the format **[BusNumber, SlotNumber]**.

To determine the bus number and the PCI slot number, type:

```
tg = slrt;  
getPCIInfo(tg, 'installed')
```

External Websites

- www.measurementcomputing.com

Measurement Computing PCI-DIO24H

Support for the MC PCI-DIO24H I/O board

Board

Measurement Computing PCI-DIO24H

General Description

The PCI-DIO24H is an I/O board with 24 digital I/O lines.

The Simulink Real-Time block library supports this board with these driver blocks:

- Measurement Computing PCI-DIO24H Digital Input
- Measurement Computing PCI-DIO24H Digital Output

Board Characteristics

Board name	PCI-DIO24H
Manufacturer	Measurement Computing
Bus type	PCI
Access method	I/O mapped
Multiple block instance support	Yes
Multiple board support	Yes

External Websites

- www.measurementcomputing.com

Measurement Computing PCI-DIO24H Digital Input

PCI-DIO24H Digital Input

Library

Simulink Real-Time Library for Measurement Computing

Note

The PCI-DIO24H has one 8255 chip with 3 ports (A,B,C). Each port has a maximum of 8 digital I/O lines that can be configured as inputs or outputs.

Use a separate driver block for each port. By selecting the digital input driver block, the port is configured as input.

Scaling Input to Output

I/O Module Input	Block Output Data Type	Scaling
TTL	Double	TTL low = 0.0 TTL high = 1.0

Block Parameters

Channel vector

Enter numbers between 1 and 8 to select the digital input lines used with this port. This driver allows the selection of individual digital input lines in arbitrary order. The number of elements defines the number of digital lines used.

For example, to use all of the digital inputs for one port, enter

```
[1,2,3,4,5,6,7,8]
```

Number the lines beginning with 1 even if this board manufacturer numbers the lines beginning with 0.

Port

From the list choose either **A**, **B**, or **C**. The I/O board has an 8255 chip with 3 ports. The **Port** parameter defines which port of the 8255 chip is used for this driver block. Each port has a maximum of 8 digital lines that can be configured as inputs or outputs depending on which driver block is chosen. In each case, one block is required for each port.

Sample time

Enter the base sample time or a multiple of the base sample time (- 1 means sample time is inherited).

PCI slot (-1:autosearch)

If only one board of this type is in the target computer, enter -1 to locate the board.

If two or more boards of this type are in the target computer, enter the bus number and the PCI slot number of the board associated with this driver block. Use the format [**BusNumber**,**SlotNumber**].

To determine the bus number and the PCI slot number, type:

```
tg = slrt;  
getPCIInfo(tg, 'installed')
```

External Websites

- www.measurementcomputing.com

Measurement Computing PCI-DIO24H Digital Output

PCI-DIO24H Digital Output

Library

Simulink Real-Time Library for Measurement Computing

Note

The PCI-DIO24H has one 8255 chip with 3 ports (A,B,C). Each port has a maximum of 8 digital I/O lines that can be configured as inputs or outputs.

Use a separate driver block for each port. By selecting the digital output driver block, the port is configured as output.

Scaling Input to Output

I/O Module Output	Block Input Data Type	Scaling
TTL	Double	< 0.5 = TTL low ≥ 0.5 = TTL high

Block Parameters

Channel vector

Enter numbers between 1 and 8 to select the digital output lines used with this port. This driver allows the selection of individual digital output lines in arbitrary order. The number of elements defines the number of digital lines used.

For example, to use all of the digital outputs for one port, enter

```
[1,2,3,4,5,6,7,8]
```

Number the lines beginning with 1 even if this board manufacturer numbers the lines beginning with 0.

Port

From the list choose either **A**, **B**, or **C**. The I/O board has an 8255 chip with 3 ports. The **Port** parameter defines which port of the 8255 chip is used for this driver block. Each port has a maximum of 8 digital lines that can be configured as inputs or outputs depending on which driver block is chosen. In each case, one block is required for each port.

Reset vector

The reset vector controls the behavior of the channel at model termination. Enter a scalar or a vector that is the same length as the channel vector. If you specify a scalar value, that setting is replicated over the channel vector. If you specify a value of 1, the corresponding channel is reset to the value specified in the initial value vector. If you specify a value of 0, the channel remains at the last value attained while the model was running.

Initial value vector

The initial value vector contains the initial values (0 or 1) of the output channels. Enter a scalar or a vector that is the same length as the channel vector. If you enter a scalar, that value is replicated as the initial value over the channel vector. The channels are set to these initial values between the time the model is downloaded and the time it is started.

Sample time

Enter the base sample time or a multiple of the base sample time (-1 means sample time is inherited).

PCI slot (-1:autosearch)

If only one board of this type is in the target computer, enter -1 to locate the board.

If two or more boards of this type are in the target computer, enter the bus number and the PCI slot number of the board associated with this driver block. Use the format **[BusNumber, SlotNumber]**.

To determine the bus number and the PCI slot number, type:

```
tg = slrt;  
getPCIInfo(tg, 'installed')
```

External Websites

- www.measurementcomputing.com

Measurement Computing PCI-DIO48H

Support for the MC PCI-DIO48H I/O board

Board

Measurement Computing PCI-DIO48H

General Description

The PCI-DIO48H is an I/O board with 48 digital I/O lines.

The Simulink Real-Time block library supports this board with these driver blocks:

- Measurement Computing PCI-DIO48H Digital Input
- Measurement Computing PCI-DIO48H Digital Output

Board Characteristics

Board name	PCI-DIO48H
Manufacturer	Measurement Computing
Bus type	PCI
Access method	I/O mapped
Multiple block instance support	Yes
Multiple board support	Yes

External Websites

- www.measurementcomputing.com

Measurement Computing PCI-DIO48H Digital Input

PCI-DIO48H Digital Input

Library

Simulink Real-Time Library for Measurement Computing

Note

The PCI-DIO48H has two 8255 chips (1,2). Each chip has three ports (A,B,C). Each port has a maximum of 8 digital I/O lines that can be configured as inputs or outputs.

Use a separate driver block for each port. By selecting the digital input driver block, the port is configured as input.

Scaling Input to Output

I/O Module Input	Block Output Data Type	Scaling
TTL	Double	TTL low = 0.0 TTL high = 1.0

Block Parameters

Channel vector

Enter numbers between 1 and 8 to select the digital input lines used with this port. This driver allows the selection of individual digital input lines in arbitrary order. The number of elements defines the number of digital lines used.

For example, to use all of the digital inputs for one port, enter

```
[1,2,3,4,5,6,7,8]
```

Number the lines beginning with 1 even if this board manufacturer numbers the lines beginning with 0.

Port

From the list choose either **A**, **B**, or **C**. The I/O board has two 8255 chips with 3 ports. The **Port** parameter defines which port of the 8255 chip is used for this driver block. Each port has a maximum of 8 digital lines that can be configured as inputs or outputs depending on which driver block is chosen. In each case, one block is required for each port.

Chip

From the list choose **1** or **2**. The **Chip** parameter defines which of the two 8255 chips is used.

Sample time

Enter the base sample time or a multiple of the base sample time (- 1 means sample time is inherited).

PCI slot (-1:autosearch)

If only one board of this type is in the target computer, enter - 1 to locate the board.

If two or more boards of this type are in the target computer, enter the bus number and the PCI slot number of the board associated with this driver block. Use the format **[BusNumber,SlotNumber]**.

To determine the bus number and the PCI slot number, type:

```
tg = slrt;  
getPCIInfo(tg, 'installed')
```

External Websites

- www.measurementcomputing.com

Measurement Computing PCI-DIO48H Digital Output

PCI-DIO48H Digital Output

Library

Simulink Real-Time Library for Measurement Computing

Note

The PCI-DIO48H has two 8255 chips (1,2). Each chip has three ports (A,B,C). Each port has a maximum of 8 digital I/O lines that can be configured as inputs or outputs.

Use a separate driver block for each port. By selecting the digital output driver block, the port is configured as output.

Scaling Input to Output

I/O Module Output	Block Input Data Type	Scaling
TTL	Double	< 0.5 = TTL low ≥ 0.5 = TTL high

Block Parameters

Channel vector

Enter numbers between 1 and 8 to select the digital output lines used with this port. This driver allows the selection of individual digital output lines in arbitrary order. The number of elements defines the number of digital lines used.

For example, to use all of the digital inputs for one port, enter

```
[1,2,3,4,5,6,7,8]
```

Number the lines beginning with 1 even if this board manufacturer numbers the lines beginning with 0.

Port

From the list choose either **A**, **B**, or **C**. The I/O board has two 8255 chips with 3 ports. The **Port** parameter defines which port of the 8255 chip is used for this driver block. Each port has a maximum of 8 digital lines that can be configured as inputs or outputs depending on which driver block is chosen. In each case, one block is required for each port.

Reset vector

The reset vector controls the behavior of the channel at model termination. Enter a scalar or a vector that is the same length as the channel vector. If you specify a scalar value, that setting is replicated over the channel vector. If you specify a value of 1, the corresponding channel is reset to the value specified in the initial value vector. If you specify a value of 0, the channel remains at the last value attained while the model was running.

Initial value vector

The initial value vector contains the initial values (0 or 1) of the output channels. Enter a scalar or a vector that is the same length as the channel vector. If you enter a scalar, that value is replicated as the initial value over the channel vector. The channels are set to these initial values between the time the model is downloaded and the time it is started.

Chip

From the list choose 1 or 2. The **Chip** parameter defines which of the two 8255 chips is used.

Sample time

Enter the base sample time or a multiple of the base sample time (- 1 means sample time is inherited).

PCI slot (-1:autosearch)

If only one board of this type is in the target computer, enter - 1 to locate the board.

If two or more boards of this type are in the target computer, enter the bus number and the PCI slot number of the board associated with this driver block. Use the format [**BusNumber**,**SlotNumber**].

To determine the bus number and the PCI slot number, type:

```
tg = slrt;
```

```
getPCIInfo(tg, 'installed')
```

External Websites

- www.measurementcomputing.com

Measurement Computing PCI-DIO96H

Support for the MC PCI-DIO96H I/O board

Board

Measurement Computing PCI-DIO96H

General Description

The PCI-DIO96H is an I/O board with 96 digital I/O lines.

The Simulink Real-Time block library supports this board with these driver blocks:

- Measurement Computing PCI-DIO96H Digital Input
- Measurement Computing PCI-DIO96H Digital Output

Board Characteristics

Board name	PCI-DIO96H
Manufacturer	Measurement Computing
Bus type	PCI
Access method	I/O mapped
Multiple block instance support	Yes
Multiple board support	Yes

External Websites

- www.measurementcomputing.com

Measurement Computing PCI-DIO96H Digital Input

PCI-DIO96H Digital Input

Library

Simulink Real-Time Library for Measurement Computing

Note

The PCI-DIO96H has four 8255 chips (1,2,3,4). Each chip has three ports (A,B,C). Each port has a maximum of 8 digital I/O lines that can be configured as inputs or outputs.

Use a separate driver block for each port. By selecting the digital input driver block, the port is configured as input.

Scaling Input to Output

I/O Module Input	Block Output Data Type	Scaling
TTL	Double	TTL low = 0.0 TTL high = 1.0

Block Parameters

Channel vector

Enter numbers between 1 and 8 to select the digital input lines used with this port. This driver allows the selection of individual digital input lines in arbitrary order. The number of elements defines the number of digital lines used.

For example, to use all of the digital inputs for one port, enter

```
[1,2,3,4,5,6,7,8]
```

Number the lines beginning with 1 even if this board manufacturer numbers the lines beginning with 0.

Port

From the list choose either **A**, **B**, or **C**. The I/O board has two 8255 chips with 3 ports. The **Port** parameter defines which port of the 8255 chip is used for this driver block. Each port has a maximum of 8 digital lines that can be configured as inputs or outputs depending on which driver block is chosen. In each case, one block is required for each port.

Chip

From the list choose **1**, **2**, **3**, or **4**. The **Chip** parameter defines which of the four 8255 chips is used.

Sample time

Enter the base sample time or a multiple of the base sample time (- 1 means sample time is inherited).

PCI slot (-1:autosearch)

If only one board of this type is in the target computer, enter - 1 to locate the board.

If two or more boards of this type are in the target computer, enter the bus number and the PCI slot number of the board associated with this driver block. Use the format **[BusNumber,SlotNumber]**.

To determine the bus number and the PCI slot number, type:

```
tg = slrt;  
getPCIInfo(tg, 'installed')
```

External Websites

- www.measurementcomputing.com

Measurement Computing PCI-DIO96H Digital Output

PCI-DIO96H Digital Output

Library

Simulink Real-Time Library for Measurement Computing

Note

The PCI-DIO96H has four 8255 chips (1,2,3,4). Each chip has three ports (A,B,C). Each port has a maximum of 8 digital I/O lines that can be configured as inputs or outputs.

Use a separate driver block for each port. By selecting the digital output driver block, the port is configured as output.

Scaling Input to Output

I/O Module Output	Block Input Data Type	Scaling
TTL	Double	$< 0.5 = \text{TTL low}$ $\geq 0.5 = \text{TTL high}$

Block Parameters

Channel vector

Enter numbers between 1 and 8 to select the digital output lines used with this port. This driver allows the selection of individual digital output lines in arbitrary order. The number of elements defines the number of digital lines used.

For example, to use all of the digital inputs for one port, enter

```
[1,2,3,4,5,6,7,8]
```

Number the lines beginning with 1 even if this board manufacturer numbers the lines beginning with 0.

Port

From the list choose either **A**, **B**, or **C**. The I/O board has two 8255 chips with 3 ports. The **Port** parameter defines which port of the 8255 chip is used for this driver block. Each port has a maximum of 8 digital lines that can be configured as inputs or outputs depending on which driver block is chosen. In each case, one block is required for each port.

Reset vector

The reset vector controls the behavior of the channel at model termination. Enter a scalar or a vector that is the same length as the channel vector. If you specify a scalar value, that setting is replicated over the channel vector. If you specify a value of 1, the corresponding channel is reset to the value specified in the initial value vector. If you specify a value of 0, the channel remains at the last value attained while the model was running.

Initial value vector

The initial value vector contains the initial values (0 or 1) of the output channels. Enter a scalar or a vector that is the same length as the channel vector. If you enter a scalar, that value is replicated as the initial value over the channel vector. The channels are set to these initial values between the time the model is downloaded and the time it is started.

Chip

From the list choose 1, 2, 3, or 4. The **Chip** parameter defines which of the four 8255 chips is used.

Sample time

Enter the base sample time or a multiple of the base sample time (-1 means sample time is inherited).

PCI slot (-1:autosearch)

If only one board of this type is in the target computer, enter -1 to locate the board.

If two or more boards of this type are in the target computer, enter the bus number and the PCI slot number of the board associated with this driver block. Use the format [**BusNumber**,**SlotNumber**].

To determine the bus number and the PCI slot number, type:

```
tg = slrt;
```

```
getPCIInfo(tg, 'installed')
```

External Websites

- www.measurementcomputing.com

Measurement Computing PCI-DIO96

Support for the MC PCI-DIO96 I/O board

Board

Measurement Computing PCI-DIO96

General Description

The PCI-DIO96 is an I/O board with 96 digital I/O lines.

The Simulink Real-Time block library supports this board with these driver blocks:

- Measurement Computing PCI-DIO96 Digital Input
- Measurement Computing PCI-DIO96 Digital Output

Board Characteristics

Board name	PCI-DIO96
Manufacturer	Measurement Computing
Bus type	PCI
Access method	I/O mapped
Multiple block instance support	Yes
Multiple board support	Yes

External Websites

- www.measurementcomputing.com

Measurement Computing PCI-DIO96 Digital Input

PCI-DIO96 Digital Input block

Library

Simulink Real-Time Library for Measurement Computing

Note

The PCI-DIO96 has four 8255 chips (1,2,3,4). Each chip has three ports (A,B,C). Each port has a maximum of 8 digital I/O lines that can be configured as inputs or outputs.

Use a separate driver block for each port. By selecting the digital input driver block, the port is configured as input.

Scaling Input to Output

I/O Module Input	Block Output Data Type	Scaling
TTL	Double	TTL low = 0.0 TTL high = 1.0

Block Parameters

Channel vector

Enter numbers between 1 and 8 to select the digital input lines used with this port. This driver allows the selection of individual digital input lines in arbitrary order. The number of elements defines the number of digital lines used.

For example, to use all of the digital inputs for one port, enter

```
[1,2,3,4,5,6,7,8]
```

Number the lines beginning with 1 even if this board manufacturer numbers the lines beginning with 0.

Port

From the list choose either **A**, **B**, or **C**. The **Port** parameter defines which port of the current 8255 chip is used for this driver block.

Chip

From the list choose **1**, **2**, **3**, or **4**. The **Chip** parameter defines which of the four 8255 chips is used.

Sample time

Enter the base sample time or a multiple of the base sample time (- 1 means sample time is inherited).

PCI slot (-1:autosearch)

If only one board of this type is in the target computer, enter - 1 to locate the board.

If two or more boards of this type are in the target computer, enter the bus number and the PCI slot number of the board associated with this driver block. Use the format [**BusNumber**,**SlotNumber**].

To determine the bus number and the PCI slot number, type:

```
tg = slrt;  
getPCIInfo(tg, 'installed')
```

External Websites

- www.measurementcomputing.com

Measurement Computing PCI-DIO96 Digital Output

PCI-DIO96 Digital Output block

Library

Simulink Real-Time Library for Measurement Computing

Note

The PCI-DIO96 has four 8255 chips (1,2,3,4). Each chip has three ports (A,B,C). Each port has a maximum of 8 digital I/O lines that can be configured as inputs or outputs.

Use a separate driver block for each port. By selecting the digital output driver block, the port is configured as output.

Scaling Input to Output

I/O Module Output	Block Input Data Type	Scaling
TTL	Double	< 0.5 = TTL low ≥ 0.5 = TTL high

Block Parameters

Channel vector

Enter numbers between 1 and 8 to select the digital output lines used with this port. This driver allows the selection of individual digital output lines in arbitrary order. The number of elements defines the number of digital lines used.

For example, to use all of the digital inputs for one port, enter

```
[1,2,3,4,5,6,7,8]
```

Number the lines beginning with 1 even if this board manufacturer numbers the lines beginning with 0.

Port

From the list choose either **A**, **B**, or **C**. The **Port** parameter defines which port of the current 8255 chip is used for this driver block.

Reset vector

The reset vector controls the behavior of the channel at model termination. Enter a scalar or a vector that is the same length as the channel vector. If you specify a scalar value, that setting is replicated over the channel vector. If you specify a value of 1, the corresponding channel is reset to the value specified in the initial value vector. If you specify a value of 0, the channel remains at the last value attained while the model was running.

Initial value vector

The initial value vector contains the initial values (0 or 1) of the output channels. Enter a scalar or a vector that is the same length as the channel vector. If you enter a scalar, that value is replicated as the initial value over the channel vector. The channels are set to these initial values between the time the model is downloaded and the time it is started.

Chip

From the list choose 1, 2, 3, or 4. The **Chip** parameter defines which of the four 8255 chips is used.

Sample time

Enter the base sample time or a multiple of the base sample time (-1 means sample time is inherited).

PCI slot (-1:autosearch)

If only one board of this type is in the target computer, enter -1 to locate the board.

If two or more boards of this type are in the target computer, enter the bus number and the PCI slot number of the board associated with this driver block. Use the format [**BusNumber**, **SlotNumber**].

To determine the bus number and the PCI slot number, type:

```
tg = slrt;  
getPCIInfo(tg, 'installed')
```

External Websites

- www.measurementcomputing.com

Measurement Computing PCI-PDISO8

Support for the PCI-PDISO8 I/O board

Board

Measurement Computing PCI-PDISO8

General Description

The PCI-PDISO8 is an I/O board with eight inputs and eight relay outputs.

The Simulink Real-Time block library supports this board with these driver blocks:

- Measurement Computing PCI-PDISO8 Digital Input
- Measurement Computing PCI-PDISO8 Digital Output

Board Characteristics

Board name	PCI-PDISO8
Manufacturer	Measurement Computing
Bus type	PCI
Access method	Memory mapped
Multiple block instance support	Yes
Multiple board support	Yes

External Websites

- www.measurementcomputing.com

Measurement Computing PCI-PDISO8 Digital Input

PCI-PDISO8 Digital Input block

Library

Simulink Real-Time Library for Measurement Computing

Scaling Input to Output

I/O Module Input	Block Output Data Type	Scaling
OPTO	Double	Low (opto off) = 0.0 High (opto on) = 1.0

The input is rectified before being applied to the opto isolator on the input. Without an additional input current limiting resistor, the opto turns on when $|V_{in}| > 3$ volts.

Block Parameters

Channel vector

Enter numbers between 1 and 8 to select the digital input lines used with this port. This driver allows the selection of individual digital input lines in arbitrary order. The number of elements defines the number of digital lines used.

For example, to use all of the digital inputs, enter

[1,2,3,4,5,6,7,8]

Number the lines beginning with 1 even if this board manufacturer numbers the lines beginning with 0.

Filter vector

This vector controls the 5 ms noise filter. It is the same length as the channel vector. A value of 1 turns the filter on, and a value of 0 turns the filter off. If you specify a scalar, this value is replicated across the channel vector.

Port

From the list choose A because this board only has eight channels.

Sample time

Enter the base sample time or a multiple of the base sample time (- 1 means sample time is inherited).

PCI slot (-1:autosearch)

If only one board of this type is in the target computer, enter - 1 to locate the board.

If two or more boards of this type are in the target computer, enter the bus number and the PCI slot number of the board associated with this driver block. Use the format [**BusNumber,SlotNumber**].

To determine the bus number and the PCI slot number, type:

```
tg = slrt;  
getPCIInfo(tg, 'installed')
```

External Websites

- www.measurementcomputing.com

Measurement Computing PCI-PDISO8 Digital Output

PCI-PDISO8 Digital Output

Library

Simulink Real-Time Library for Measurement Computing

Scaling Input to Output

I/O Module Output	Block Input Data Type	Scaling
RELAY	Double	$< 0.5 = \text{relay off}$ $\geq 0.5 = \text{relay on}$

Block Parameters

Channel vector

Enter numbers between 1 and 8 to select the digital output lines to drive. This driver allows the selection of individual digital output lines in arbitrary order. The number of elements defines the number of digital lines used.

For example, to use all of the digital outputs, enter

[1, 2, 3, 4, 5, 6, 7, 8]

Number the lines beginning with 1 even if this board manufacturer numbers the lines beginning with 0.

Port

From the list choose A because this board only has eight channels.

Sample time

Enter the base sample time or a multiple of the base sample time (- 1 means sample time is inherited).

PCI slot (-1:autosearch)

If only one board of this type is in the target computer, enter - 1 to locate the board.

If two or more boards of this type are in the target computer, enter the bus number and the PCI slot number of the board associated with this driver block. Use the format **[BusNumber,SlotNumber]**.

To determine the bus number and the PCI slot number, type:

```
tg = slrt;  
getPCIInfo(tg, 'installed')
```

External Websites

- www.measurementcomputing.com

Measurement Computing PCI-PDISO16

Support for the MC PCI-PDISO16 I/O board

Board

Measurement Computing PCI-PDISO16

General Description

The PCI-PDISO16 is an I/O board with 16 inputs and 16 relay outputs.

The Simulink Real-Time block library supports this board with these driver blocks:

- Measurement Computing PCI-PDISO16 Digital Input
- Measurement Computing PCI-PDISO16 Digital Output

Board Characteristics

Board name	PCI-PDISO16
Manufacturer	Measurement Computing
Bus type	PCI
Access method	Memory mapped
Multiple block instance support	Yes
Multiple board support	Yes

External Websites

- www.measurementcomputing.com

Measurement Computing PCI-PDISO16 Digital Input

PCI-PDISO16 Digital Input block

Library

Simulink Real-Time Library for Measurement Computing

Scaling Input to Output

I/O Module Input	Block Output Data Type	Scaling
OPTO	Double	Low (opto off) = 0.0 High (opto on) = 1.0

The input is rectified before being applied to the opto isolator on the input. Without an additional input current limiting resistor, the opto turns on when $|V_{in}| > 3$ volts.

Block Parameters

Channel vector

Enter numbers between 1 and 8 to select the digital input lines used with this port. This driver allows the selection of individual digital input lines in arbitrary order. The number of elements defines the number of digital lines used.

For example, to use all of the digital inputs, enter

```
[1,2,3,4,5,6,7,8]
```

Number the lines beginning with 1 even if this board manufacturer numbers the lines beginning with 0.

Filter vector

This vector controls the 5 ms noise filter. It is the same length as the channel vector. A value of 1 turns the filter on, and a value of 0 turns the filter off. If you specify a scalar, this value is replicated across the channel vector.

Port

From the list choose either **A** or **B**. The **Port** parameter defines which port is used for this driver block. Each port has a maximum of 8 digital inputs. More than one block can be connected to the same port, but each channel can only be referenced by one block at a time.

Sample time

Enter the base sample time or a multiple of the base sample time (- 1 means sample time is inherited).

PCI slot (-1:autosearch)

If only one board of this type is in the target computer, enter - 1 to locate the board.

If two or more boards of this type are in the target computer, enter the bus number and the PCI slot number of the board associated with this driver block. Use the format [**BusNumber,SlotNumber**].

To determine the bus number and the PCI slot number, type:

```
tg = slrt;  
getPCIInfo(tg, 'installed')
```

External Websites

- www.measurementcomputing.com

Measurement Computing PCI-PDISO16 Digital Output

PCI-PDISO16 Digital Output block

Library

Simulink Real-Time Library for Measurement Computing

Scaling Input to Output

I/O Module Output	Block Input Data Type	Scaling
RELAY	Double	< 0.5 = relay off ≥ 0.5 = relay on

Block Parameters

Channel vector

Enter numbers between 1 and 8 to select the digital output lines to drive. This driver allows the selection of individual digital output lines in arbitrary order. The number of elements defines the number of digital lines used.

For example, to use all of the digital outputs, enter

```
[1,2,3,4,5,6,7,8]
```

Number the lines beginning with 1 even if this board manufacturer numbers the lines beginning with 0.

Port

From the list choose either A or B. The **Port** parameter defines which port is used for this driver block. Each port has a maximum of 8 digital outputs. More than one output block can be used with the same port, but each output channel can only be controlled by one block at a time.

Sample time

Enter the base sample time or a multiple of the base sample time (- 1 means sample time is inherited).

PCI slot (-1:autosearch)

If only one board of this type is in the target computer, enter - 1 to locate the board.

If two or more boards of this type are in the target computer, enter the bus number and the PCI slot number of the board associated with this driver block. Use the format [**BusNumber,SlotNumber**].

To determine the bus number and the PCI slot number, type:

```
tg = slrt;  
getPCIInfo(tg, 'installed')
```

External Websites

- www.measurementcomputing.com

Measurement Computing PCIM-DAS1602/16

Support for the MC PCIM-DAS1602/16 I/O board

Board

Measurement Computing PCIM-DAS1602/16

General Description

The PCIM-DAS1602/16 is an I/O board with 16 single or 8 differential analog input (A/D) channels (16-bit) with a maximum sampling rate of 100 kHz, 2 analog output (D/A) channels (16-bit), and 24 digital input and output lines and 3 counters (16-bit).

Note: The Simulink Real-Time software supports only 24 digital I/O lines and does not support the counters on this board.

The Simulink Real-Time block library supports this board with these driver blocks:

- Measurement Computing PCIM-DAS1602/16 Analog Input (A/D)
- Measurement Computing PCIM-DAS1602/16 Analog Output (D/A)
- Measurement Computing PCIM-DAS 1602/16 Digital Input
- Measurement Computing PCIM-DAS1602/16 Digital Output

Board Characteristics

Board Name	PCIM-DAS1602/16
Manufacturer	Measurement Computing
Bus type	PCI
Access method	I/O mapped
Multiple block instance support	Yes

Multiple board support

Yes

External Websites

- www.measurementcomputing.com

Measurement Computing PCIM-DAS1602/16 Analog Input (A/D)

PCIM-DAS1602/16 Analog Input block

Library

Simulink Real-Time Library for Measurement Computing

Scaling of Input to Output

I/O Module Input	Block Output Data Type	Scaling
Volts	Double	1

Block Parameters

Number of channels

If you select 16 channels (**Input coupling** parameter set to 16 single-ended channels) enter a number between 1 and 16 to select the number of A/D channels used. If you select eight channels (**Input coupling** parameter set to 8 differential channels) enter a number between 1 and 8. This driver does not allow the selection of individual channels or to mix single-ended and differential inputs.

Number the lines beginning with 1 even if this board manufacturer numbers the lines beginning with 0.

Range

From the list, choose either $\pm 10V$ (-10 volts to +10 volts), $\pm 5V$, $\pm 2.5V$, $\pm 1.25V$, $\pm 0.625V$, $0-10V$, $0-5V$, $0-2.5V$, or $0-1.25V$. This driver does not allow the selection of a different range for each channel.

If a bipolar range is used, the bipolar switch on the board must be in the bipolar position. If a unipolar range is used, the bipolar switch must be in the unipolar position.

Input coupling

From the list, select one from the following list of input modes:

- Single-ended channels (16 channels)
- Differential channels (8 channels)

This choice must correspond to the MUX-switch setting on the board.

Sample time

Enter the base sample time or a multiple of the base sample time (- 1 means sample time is inherited).

PCI slot (-1:autosearch)

If only one board of this type is in the target computer, enter - 1 to locate the board.

If two or more boards of this type are in the target computer, enter the bus number and the PCI slot number of the board associated with this driver block. Use the format **[BusNumber, SlotNumber]**.

To determine the bus number and the PCI slot number, type:

```
tg = slrt;  
getPCIInfo(tg, 'installed')
```

External Websites

- www.measurementcomputing.com

Measurement Computing PCIM-DAS1602/16 Analog Output (D/A)

PCIM-DAS1602/16 Analog Output block

Library

Simulink Real-Time Library for Measurement Computing

Scaling of Input to Output

I/O Module Output	Block Input Data Type	Scaling
Volts	Double	1

Block Parameters

Channel vector

Enter 1 or 2. This driver allows the selection of individual D/A channels in arbitrary order. The number of elements defines the number of D/A channels used. For example, to use the first and second analog output (D/A) channels, enter

[1,2]

Number channels begin with 1 even if this board manufacturer starts numbering channels with 0.

Range vector

Enter a range code for each of the channels in the channel vector. The range vector must be the same length as the channel vector. This board allows the range of each channel to be different.

The following table is a list of the ranges for this driver and the corresponding range codes.

Input Range (V)	Range Code
-10 to +10	-10

Input Range (V)	Range Code
-5 to +5	-5
0 to +10	10
0 to +5	5

For example, if the first channel is -10 to +10 volts and the second channel is 0 to +5 volts, enter

```
[ -10,5]
```

The range settings must correspond to the DIP switch settings on the board. Also the bipolar/unipolar jumpers must be inserted according to the ranges used.

Reset vector

The reset vector controls the behavior of the channel at model termination. Enter a scalar or a vector that is the same length as the channel vector. If you specify a scalar value, that setting is replicated over the channel vector. If you specify a value of 1, the corresponding channel is reset to the value specified in the initial value vector. If you specify a value of 0, the channel remains at the last value attained while the model was running.

Initial value vector

The initial value vector contains the initial voltage values for the output channels. Enter a scalar or a vector that is the same length as the channel vector. If you specify a scalar value, that value is replicated as the initial value over the channel vector. The channels are set to the initial values between the time the model is downloaded and the time it is started.

Sample time

Enter the base sample time or a multiple of the base sample time (- 1 means sample time is inherited).

PCI slot (-1:autosearch)

If only one board of this type is in the target computer, enter - 1 to locate the board.

If two or more boards of this type are in the target computer, enter the bus number and the PCI slot number of the board associated with this driver block. Use the format **[BusNumber,SlotNumber]**.

To determine the bus number and the PCI slot number, type:

```
tg = slrt;
```

```
getPCIInfo(tg, 'installed')
```

External Websites

- www.measurementcomputing.com

Measurement Computing PCIM-DAS 1602/16 Digital Input

PCIM-DAS 1602/16 Digital Input block

Library

Simulink Real-Time Library for Measurement Computing

Note

The DAS1601/16 has an 8255 chip with 3 ports (A,B,C). Each port has a maximum of 8 digital I/O lines that can be configured as inputs or outputs.

Use a separate driver block for each port. By selecting the digital input driver block, the port is configured as input.

Scaling of Input to Output

I/O Module Input	Block Output Data Type	Scaling
TTL	Double	TTL low = 0.0 TTL high = 1.0

Block Parameters

Channel vector

Enter numbers between 1 and 8 to select the digital input lines used with this port. This driver allows the selection of individual digital input lines in arbitrary order. The number of elements defines the number of digital lines used.

For example, to use all of the digital inputs for one port, enter

[1,2,3,4,5,6,7,8]

Number the lines beginning with 1 even if this board manufacturer numbers the lines beginning with 0.

Port

From the list choose either A, B, or C. The I/O board has an 8255 chip with 3 ports. The port name defines which port of the 8255 chip is used for this driver block. Each port has a maximum of 8 digital lines that can be configured as inputs or outputs depending on which driver block is chosen. In each case, one block is required for each port.

Sample time

Enter the base sample time or a multiple of the base sample time (- 1 means sample time is inherited).

PCI slot (-1:autosearch)

If only one board of this type is in the target computer, enter - 1 to locate the board.

If two or more boards of this type are in the target computer, enter the bus number and the PCI slot number of the board associated with this driver block. Use the format **[BusNumber, SlotNumber]**.

To determine the bus number and the PCI slot number, type:

```
tg = slrt;  
getPCIInfo(tg, 'installed')
```

External Websites

- www.measurementcomputing.com

Measurement Computing PCIM-DAS1602/16 Digital Output

PCIM-DAS1602/16 Digital Output

Library

Simulink Real-Time Library for Measurement Computing

Note

The PCIM-DAS1601/16 has an 8255 chip with 3 ports (A,B,C). Each port has a maximum of 8 digital I/O lines that can be configured as inputs or outputs.

Use a separate driver block for each port. By selecting the digital output driver block, the port is configured as output.

Scaling of Input to Output

I/O Module Output	Block Input Data Type	Scaling
TTL	Double	< 0.5 = TTL low ≥ 0.5 = TTL high

Block Parameters

Channel vector

Enter numbers between 1 and 8 to select the digital output lines used with this port. This driver allows the selection of individual digital output lines in arbitrary order. The number of elements defines the number of digital lines used.

For example, to use all of the digital outputs for one port, enter

[1,2,3,4,5,6,7,8]

Number the lines beginning with 1 even if this board manufacturer numbers the lines beginning with 0.

Port

From the list choose either **A**, **B**, or **C**. The I/O board has an 8255 chip with 3 ports. The port name defines which port of the 8255 chip is used for this driver block. Each port has a maximum of 8 digital lines that can be configured as inputs or outputs depending on which driver block is chosen. In each case, one block is required for each port.

Reset vector

The reset vector controls the behavior of the channel at model termination. Enter a scalar or a vector that is the same length as the channel vector. If you specify a scalar value, that setting is replicated over the channel vector. If you specify a value of 1, the corresponding channel is reset to the value specified in the initial value vector. If you specify a value of 0, the channel remains at the last value attained while the model was running.

Initial value vector

The initial value vector contains the initial values (0 or 1) of the output channels. Enter a scalar or a vector that is the same length as the channel vector. If you enter a scalar, that value is replicated as the initial value over the channel vector. The channels are set to these initial values between the time the model is downloaded and the time it is started.

Sample time

Enter the base sample time or a multiple of the base sample time (- 1 means sample time is inherited).

PCI slot (-1:autosearch)

If only one board of this type is in the target computer, enter - 1 to locate the board.

If two or more boards of this type are in the target computer, enter the bus number and the PCI slot number of the board associated with this driver block. Use the format [**BusNumber**,**SlotNumber**].

To determine the bus number and the PCI slot number, type:

```
tg = slrt;  
getPCIInfo(tg, 'installed')
```

External Websites

- www.measurementcomputing.com

Measurement Computing PCIM-DDA06/16

Support for the MC PCIM-DDA06/16 I/O board

Board

Measurement Computing PCIM-DDA06/16

General Description

The PCIM-DDA06/16) is an I/O board with 6 analog output (D/A) channels (16-bit), and 24 digital I/O lines.

The Simulink Real-Time block library supports this board with these driver blocks:

- Measurement Computing PCIM-DDA06/16 Analog Output (D/A)
- Measurement Computing PCIM-DDA06/16 Digital Input
- Measurement Computing PCIM-DDA06/16 Digital Output

Board Characteristics

Board name	PCIM-DDA06/16
Manufacturer	Measurement Computing
Bus type	PCIM
Access method	I/O mapped
Multiple block instance support	Yes
Multiple board support	Yes

External Websites

- www.measurementcomputing.com

Measurement Computing PCIM-DDA06/16 Analog Output (D/A)

PCIM-DDA06/16 Analog Output block

Library

Simulink Real-Time Library for Measurement Computing

Scaling Input to Output

I/O Module Output	Block Input Data Type	Scaling
Volts	Double	1

Block Parameters

Channel vector

Enter numbers between 1 and 6. This driver allows the selection of individual D/A channels in arbitrary order. The number of elements defines the number of D/A channels used. For example, to use the first and second analog output channels, enter

[1,2]

Number the channels beginning with 1 even if this board manufacturer starts numbering the channels with 0.

Range vector

Enter a range code for each of the channels in the channel vector. The range vector must be the same length as the channel vector. This board allows the range of each channel to be different.

The following table is a list of the ranges for this driver and the corresponding range codes.

Input Range (V)	Range Code
-10 to +10	-10

Input Range (V)	Range Code
-5 to +5	-5
-2.5 to +2.5	-2.5
-1.67 to +1.67	-1.67
-0.625 to +0.625	-0.625
0 to +10	10
0 to +5	5
0 to +2.5	2.5
0 to +1.67	1.67

For example, if the first channel is -10 to +10 volts and the second channel is 0 to +5 volts, enter

[-10,5]

The range settings must correspond to the DIP switch settings on the board.

Note: For the Simulink Real-Time software, set the Simultaneous Transfer jumper to the XFER setting.

Reset vector

The reset vector controls the behavior of the channel at model termination. Enter a scalar or a vector that is the same length as the channel vector. If you specify a scalar value, that setting is replicated over the channel vector. If you specify a value of 1, the corresponding channel is reset to the value specified in the initial value vector. If you specify a value of 0, the channel remains at the last value attained while the model was running.

Initial value vector

The initial value vector contains the initial voltage values for the output channels. Enter a scalar or a vector that is the same length as the channel vector. If you specify a scalar value, that value is replicated as the initial value over the channel vector. The channels are set to the initial values between the time the model is downloaded and the time it is started.

Sample time

Enter the base sample time or a multiple of the base sample time (- 1 means sample time is inherited).

PCI slot (-1:autosearch)

If only one board of this type is in the target computer, enter - 1 to locate the board.

If two or more boards of this type are in the target computer, enter the bus number and the PCI slot number of the board associated with this driver block. Use the format [**BusNumber**,**SlotNumber**].

To determine the bus number and the PCI slot number, type:

```
tg = slrt;  
getPCIInfo(tg, 'installed')
```

External Websites

- www.measurementcomputing.com

Measurement Computing PCIM-DDA06/16 Digital Input

PCIM-DDA06/16 Digital Input

Library

Simulink Real-Time Library for Measurement Computing

Note

The PCIM-DDA6/16 has an 8255 chip with three ports (A,B,C). Each port has a maximum of 8 digital I/O lines that can be configured as inputs or outputs.

Use a separate driver block for each port. By selecting the digital input driver block, the port is configured as input.

Scaling Input to Output

I/O Module Input	Block Output Data Type	Scaling
TTL	Double	TTL low = 0.0 TTL high = 1.0

Block Parameters

Channel vector

Enter numbers between 1 and 8 to select the digital input lines used with this port. This driver allows the selection of individual digital input lines in arbitrary order. The number of elements defines the number of digital lines used.

For example, to use all of the digital inputs for one port, enter

```
[1,2,3,4,5,6,7,8]
```

Number the lines beginning with 1 even if this board manufacturer numbers the lines beginning with 0.

Port

From the list choose either **A**, **B**, or **C**. The I/O board has two 8255 chips with 3 ports. The **Port** parameter defines which port of the 8255 chip is used for this driver block. Each port has a maximum of 8 digital lines that can be configured as inputs or outputs depending on which driver block is chosen. In each case, one block is required for each port.

Sample time

Enter the base sample time or a multiple of the base sample time (- 1 means sample time is inherited).

PCI slot (-1:autosearch)

If only one board of this type is in the target computer, enter - 1 to locate the board.

If two or more boards of this type are in the target computer, enter the bus number and the PCI slot number of the board associated with this driver block. Use the format **[BusNumber, SlotNumber]**.

To determine the bus number and the PCI slot number, type:

```
tg = slrt;  
getPCIInfo(tg, 'installed')
```

External Websites

- www.measurementcomputing.com

Measurement Computing PCIM-DDA06/16 Digital Output

PCIM-DDA06/16 Digital Output

Library

Simulink Real-Time Library for Measurement Computing

Note

The PCIM-DDA06/16 has an 8255 chip with three ports (A,B,C). Each port has a maximum of 8 digital I/O lines that can be configured as inputs or outputs.

Use a separate driver block for each port. By selecting the digital output driver block, the port is configured as output.

Scaling Input to Output

I/O Module Output	Block Input Data Type	Scaling
TTL	Double	< 0.5 = TTL low ≥ 0.5 = TTL high

Block Parameters

Channel vector

Enter numbers between 1 and 8 to select the digital output lines used with this port. This driver allows the selection of individual digital output lines in arbitrary order. The number of elements defines the number of digital lines used.

For example, to use all of the digital outputs for one port, enter

[1,2,3,4,5,6,7,8]

Number the lines beginning with 1 even if this board manufacturer numbers the lines beginning with 0.

Port

From the list choose either **A**, **B**, or **C**. The I/O board has two 8255 chips with 3 ports. The **Port** parameter defines which port of the 8255 chip is used for this driver block. Each port has a maximum of 8 digital lines that can be configured as inputs or outputs depending on which driver block is chosen. In each case, one block is required for each port.

Reset vector

The reset vector controls the behavior of the channel at model termination. Enter a scalar or a vector that is the same length as the channel vector. If you specify a scalar value, that setting is replicated over the channel vector. If you specify a value of 1, the corresponding channel is reset to the value specified in the initial value vector. If you specify a value of 0, the channel remains at the last value attained while the model was running.

Initial value vector

The initial value vector contains the initial values (0 or 1) of the output channels. Enter a scalar or a vector that is the same length as the channel vector. If you enter a scalar, that value is replicated as the initial value over the channel vector. The channels are set to these initial values between the time the model is downloaded and the time it is started.

Sample time

Enter the base sample time or a multiple of the base sample time (- 1 means sample time is inherited).

PCI slot (-1:autosearch)

If only one board of this type is in the target computer, enter - 1 to locate the board.

If two or more boards of this type are in the target computer, enter the bus number and the PCI slot number of the board associated with this driver block. Use the format [**BusNumber**,**SlotNumber**].

To determine the bus number and the PCI slot number, type:

```
tg = slrt;
getPCIInfo(tg, 'installed')
```

External Websites

- www.measurementcomputing.com

Measurement Computing PCI-DUAL-AC5

Support for the MC PCI-DUAL-AC5 I/O board

Board

Measurement Computing PCI-DUAL-AC5

General Description

The PCI-DUAL-AC5 is an I/O board with 48 digital I/O lines.

The Simulink Real-Time block library supports this board with these driver blocks:

- Measurement Computing PCI-DUAL-AC5 Digital Input
- Measurement Computing PCI-DUAL-AC5 Digital Output

Board Characteristics

Board name	PCI-DUAL-AC5
Manufacturer	Measurement Computing
Bus type	compact PCI
Access method	I/O mapped
Multiple block instance support	Yes
Multiple board support	Yes

External Websites

- www.measurementcomputing.com

Measurement Computing PCI-DUAL-AC5 Digital Input

PCI-DUAL-AC5 Digital Input

Library

Simulink Real-Time Library for Measurement Computing

Note

The PCI-DUAL-AC5 has two 8255 chips (1,2). Each chip has three ports (A,B,C). Each port has a maximum of 8 digital I/O lines that can be configured as inputs or outputs.

Use a separate driver block for each port. By selecting the digital input driver block, the port is configured as input.

Scaling Input to Output

I/O Module Input	Block Output Data Type	Scaling
TTL	Double	TTL low = 0.0 TTL high = 1.0

Block Parameters

Channel vector

Enter numbers between 1 and 8 to select the digital input lines used with this port. This driver allows the selection of individual digital input lines in arbitrary order. The number of elements defines the number of digital lines used.

For example, to use all of the digital inputs for one port, enter

```
[1,2,3,4,5,6,7,8]
```

Number the lines beginning with 1 even if this board manufacturer numbers the lines beginning with 0.

Port

From the list choose either **A**, **B**, or **C**. The I/O board has two 8255 chips with 3 ports. The **Port** parameter defines which port of the 8255 chip is used for this driver block. Each port has a maximum of 8 digital lines that can be configured as inputs or outputs depending on which driver block is chosen. In each case, one block is required for each port.

Chip

From the list choose **1** or **2**. The **Chip** parameter defines which of the two 8255 chips is used.

Sample time

Enter the base sample time or a multiple of the base sample time (- 1 means sample time is inherited).

PCI slot (-1:autosearch)

If only one board of this type is in the target computer, enter - 1 to locate the board.

If two or more boards of this type are in the target computer, enter the bus number and the PCI slot number of the board associated with this driver block. Use the format **[BusNumber,SlotNumber]**.

To determine the bus number and the PCI slot number, type:

```
tg = slrt;  
getPCIInfo(tg, 'installed')
```

External Websites

- www.measurementcomputing.com

Measurement Computing PCI-DUAL-AC5 Digital Output

PCI-DUAL-AC5 Digital Output

Library

Simulink Real-Time Library for Measurement Computing

Note

The PCI-DUAL-AC5 has two 8255 chips (1,2). Each chip has three ports (A,B,C). Each port has a maximum of 8 digital I/O lines that can be configured as inputs or outputs.

Use a separate driver block for each port. By selecting the digital output driver block, the port is configured as output.

Scaling Input to Output

I/O Module Output	Block Input Data Type	Scaling
TTL	Double	< 0.5 = TTL low ≥ 0.5 = TTL high

Block Parameters

Channel vector

Enter numbers between 1 and 8 to select the digital output lines used with this port. This driver allows the selection of individual digital output lines in arbitrary order. The number of elements defines the number of digital lines used.

For example, to use all of the digital inputs for one port, enter

```
[1,2,3,4,5,6,7,8]
```

Number the lines beginning with 1 even if this board manufacturer numbers the lines beginning with 0.

Port

From the list choose either **A**, **B**, or **C**. The I/O board has two 8255 chips with 3 ports. The **Port** parameter defines which port of the 8255 chip is used for this driver block. Each port has a maximum of 8 digital lines that can be configured as inputs or outputs depending on which driver block is chosen. In each case, one block is required for each port.

Reset vector

The reset vector controls the behavior of the channel at model termination. Enter a scalar or a vector that is the same length as the channel vector. If you specify a scalar value, that setting is replicated over the channel vector. If you specify a value of 1, the corresponding channel is reset to the value specified in the initial value vector. If you specify a value of 0, the channel remains at the last value attained while the model was running.

Initial value vector

The initial value vector contains the initial values (0 or 1) of the output channels. Enter a scalar or a vector that is the same length as the channel vector. If you enter a scalar, that value is replicated as the initial value over the channel vector. The channels are set to these initial values between the time the model is downloaded and the time it is started.

Chip

From the list choose 1 or 2. The **Chip** parameter defines which of the two 8255 chips is used.

Sample time

Enter the base sample time or a multiple of the base sample time (-1 means sample time is inherited).

PCI slot (-1:autosearch)

If only one board of this type is in the target computer, enter -1 to locate the board.

If two or more boards of this type are in the target computer, enter the bus number and the PCI slot number of the board associated with this driver block. Use the format [**BusNumber**,**SlotNumber**].

To determine the bus number and the PCI slot number, type:

```
tg = slrt;
```

```
getPCIInfo(tg, 'installed')
```

External Websites

- www.measurementcomputing.com

Measurement Computing PCI-QUAD04

Support for the MC PCI-QUAD04 counting board

Board

Measurement Computing PCI-QUAD04

General Description

The PCI-QUAD04 is a 24-bit counting board with 4 channels. This board typically connects to incremental encoders. Incremental encoders convert physical motion into electrical pulses that can be used to determine velocity, direction, and distance.

The Simulink Real-Time block library supports this board with this driver block:

- Measurement Computing PCI-QUAD04 Incremental Encoder

There is a physical limitation with the PCI-Quad04 boards in the way that they handle unconnected inputs. Even with the **Index input resets counter** check box disabled, noise on the index input line might cause the counter chip on the board to latch a value that differs from the actual value by a multiple of 256. The frequency of occurrence of the bad reads depends on the count frequency coming from the encoder. High count rates result in more bad reads.

To work around this issue, try the following:

- 1 If the index signal from an encoder is not being used, connect the index inputs.
- 2 Connect the index+ input to +5 volts.
- 3 Connect the index- input to ground.

These connections should be made as close to the board as possible to minimize crosstalk at high count frequencies.

Board Characteristics

Board name

PCI-QUAD04

Manufacturer	Measurement Computing
Bus type	PCI
Access method	I/O mapped
Multiple block instance support	Yes
Multiple board support	Yes

External Websites

- www.measurementcomputing.com

Measurement Computing PCI-QUAD04 Incremental Encoder

PCI-QUAD04 Incremental Encoder

Library

Simulink Real-Time Library for Measurement Computing

Description

This driver block has one block output: **Count**.

The raw count value is a 24-bit integer that is converted to a double precision float output from the block. The 24-bit value can be interpreted in different ways (see **Count Range**).

In this section, the clockwise direction is the direction in which the counter increments. The counterclockwise direction is the direction in which the counter decrements. Note that the counter direction depends on the encoder manufacturer and the way in which the encoder is installed.

Block Parameters

Channel

From the list, choose 1, 2, 3, or 4. This parameter specifies the channel you use for this block. For the same board (same PCI slot) two blocks cannot have the same channel number.

Index input resets counter

Choose this check box to control the behavior when the index is reached. For example, a rotary encoder typically reaches the index at one particular position in its range of motion. Setting this check box to reset the count value allows you to get a repeatable position from an encoder. When the encoder reaches the index (asserts the index), the counter value is set to the value given in the **Count Limit or Reset Value** field.

Index Polarity

From the list, select the index pulse slope that the board should detect. Select **Positive Index** for a positive slope; select **Negative Index** for a negative slope.

Counting Mode

From the list, select a counting mode (**Normal**, **Range Limit**, **Non-recycle**, or **Modulo-N**). The output of the block depends on both the setting of **Index input resets counter** and on the counting mode as described in the following table.

Counting Mode	Index input resets counter Selected	Index input resets counter Deselected
Normal	<p>Upon model start, the output count is initialized to Count Limit or Reset Value. The output count increments or decreases one full revolution from the Count Limit or Reset Value. The output count is reset to this value each time the index is reached.</p> <p>For example, if Index input resets counter is selected, and a rotary encoder has 1024 counts per revolution, and a Count Limit or Reset Value of 5000, a full clockwise revolution of the encoder increments the counter to 6023, at which the index is reached. The counter then resets to 5000.</p>	<p>Upon model start, the counter is initialized to 0. The counter then increments or decrements until it either overflows or underflows. For a rotary encoder, the number of revolutions is the number of output counts divided by the number of counts per revolution. The resulting integer is the number of revolutions; the fractional part can be converted to an angle.</p>
Range Limit	<p>Upon model start, the counter increments or decrements until it reaches the count limit Count Limit or Reset Value. If the clock motion is clockwise, the counter stays at Count Limit or Reset Value once it reaches that value. If the clock motion is counterclockwise, the counter decrements one revolution then resets to Count Limit or Reset Value.</p>	<p>Upon model start, the counter is initialized to 0. In the clockwise direction, the counter increments until it saturates at Count Limit or Reset Value. In the counterclockwise direction, the counter decrements until it saturates at 0.</p> <p>You can use this setting to set a repeatable 0 when there is a mechanical stop. At model start, the count is initialized to 0. The machine then shifts to the</p>

Counting Mode	Index input resets counter Selected	Index input resets counter Deselected
		negative direction stop. At that point, the encoder reports 0 at the stop and the other positions will be positive and repeatable.
Non-recycle	Upon model start, the counter is initialized to Count Limit or Reset Value . With counterclockwise rotation, the counter decrements and saturates at 0. If the encoder reaches the index before the counter saturates at 0, the counter resets to Count Limit or Reset Value . With clockwise rotation, the counter increments until the encoder reaches the index. When the encoder reaches the index, the counter resets to Count Limit or Reset Value . You can use this setting to place 0 at the first index inside a mechanical limit.	The behavior of this option is undefined.
Modulo-N	The behavior of this option is undefined.	Upon model start, the counter is initialized to 0. In the clockwise direction, the counter increments to Count Limit or Reset Value , then resets to 0 and repeats. When the counter decrements, it counts to 0, then resets to Count Limit or Reset Value and continues to decrement. You can use this setting to repeat intervals that do not match the distance between indexes (resulting, for example, from gear ratios).

Count Limit or Reset Value

The preset register (PR) on the counter chip is a 24-bit quantity. The counter uses this value as a limit for the Range Limit, Non-recycle, and Modulo-N counting modes.

When **Index input resets counter** is selected, this value acts as both the initial value at model start and the value that an index resets the count to.

You can enter negative limit values, but the counter treats them as large positive values. For example, a limit of -1 results in the `Modulo-N` range from 0 to $2^{24} - 1$, not from -1 to 0 .

Count Range

From the list, choose $0 \dots 2^{24} - 1$ or $-2^{23} \dots +2^{23} - 1$. The counter uses a 24-bit accumulator which overflows from $2^{24} - 1$ to 0 . This same overflow can be interpreted as the transition from -1 to 0 . Selecting the unipolar range 0 to $2^{24} - 1$ puts the discontinuity in counts at 0 . Selecting the bipolar range of $(-2)^{23}$ to $(-2)^{23} - 1$ puts the discontinuity far away from 0 . The bipolar range is achieved by sign extending the 24-bit count to 32 bits before converting to `double`.

Count Speed

From the list, choose `non-quadrature`, `1X`, `2X`, or `4X`:

- `non-quadrature` — Counts the rising edges of the A input, losing direction information in the process. The presence of a quadrature signal on the B input might cause undefined results. You should disconnect the B and index inputs.
- `1X` — Counts up or down once per complete cycle of the quadrature signal.
- `2X` — Counts up or down twice per complete cycle of the quadrature signal.
- `4X` — Counts up or down four times per complete cycle of the quadrature signal.

Filter prescale factor

Enter a base prescale factor for digital filtering. This filter helps eliminate high frequency noise. Enter a value from `0` to `ff` in hexadecimal (0 to 256 in decimal). For example, for a prescale factor value of `ff` in hexadecimal, enter

```
0xff
```

Sample time

Enter a base sample time or a multiple of the base sample time. The sample time indicates the update rate of registration on the input (Duty Cycle). Enter `-1` to inherit the model sample time from another block. The sample time is in seconds.

PCI slot (-1:autosearch)

If only one board of this type is in the target computer, enter `-1` to locate the board.

If two or more boards of this type are in the target computer, enter the bus number and the PCI slot number of the board associated with this driver block. Use the format **[BusNumber,SlotNumber]**.

To determine the bus number and the PCI slot number, type:

```
tg = slrt;  
getPCIInfo(tg, 'installed')
```

External Websites

- www.measurementcomputing.com

Measurement Computing PCI-DAS-TC

Support for the MC PCI-DAS-TC I/O board

Board

Measurement Computing PCI-DAS-TC

General Description

The PCI-DAS-TC is an I/O board with 16 differential analog thermocouple input channels. The thermocouple signals are converted by a high frequency synchronous V-F A/D converter. The board is equipped with its own micro-controller responsible for calibration, cold junction compensation, moving average calculations, conversion, and conversion into physical engineering units. The onboard micro-controller significantly off loads the main CPU.

The Simulink Real-Time block library supports this board with this driver block:

- Measurement Computing PCI-DAS-TC Thermocouple

Board Characteristics

Board name	PCI-DAS-TC
Manufacturer	Measurement Computing
Bus type	PCI
Access method	I/O mapped
Multiple block instance support	No
Multiple board support	Yes

External Websites

- www.measurementcomputing.com

Measurement Computing PCI-DAS-TC Thermocouple

PCI-DAS-TC Thermocouple

Library

Simulink Real-Time Library for Measurement Computing

Scaling Input to Output

I/O Module Input	Block Input Data Type	Scaling
Volts	Double	temperature in either degrees C, K, or F.

Block Parameters

Conversion rate (interrogation time)

From the list, choose either 50Hz, 60Hz, or 400 Hz. This is the conversion rate for the V-F A/D converter. The conversion rate is the same for all input channels.

Number of samples for moving average

From the list, choose a value from 1 to 16. Converted signal values are put into a cyclic buffer of size N which is used to calculate the moving average over these N samples.

Number of channels to be acquired (1..n)

From the list, choose a value from 1 to 16. This is the number of input channels activated for conversion. The first channel of the scan is an input channel with the number 1 and the last channel has the number N .

Vector input thermocouple types (cell array of char)

For each acquired channel, enter a valid type of either 'J', 'K', 'E', 'T', 'R', 'S', or 'B'. This vector defines the type of thermocouple for each channel. The vector must be the same length as the **Number of channels to be acquired**.

Vector of input gains (double array)

For each acquired channel, enter a valid input gain of either 1, 125, 166.7, or 400. This vector defines the input gain for each channel. The vector must be the same length as the **Number of channels to be acquired**.

Vector or temperature formats (cell array of char)

For each acquired channel, enter a valid format of either 'C' or 'F'. 'C' = Celsius and 'F' = Fahrenheit. The vector must be the same length as the **Number of channels to be acquired**.

Read and output CJC temperature

If you want the block to read, convert, and output the temperature of the cold junction (CJC) sensor on the board, select this check box. If selected, the block shows an additional output port with the value of the CJC temperature.

Sample time

Enter the base sample time or a multiple of the base sample time (-1 means sample time is inherited).

PCI slot (-1:autosearch)

If only one board of this type is in the target computer, enter -1 to locate the board.

If two or more boards of this type are in the target computer, enter the bus number and the PCI slot number of the board associated with this driver block. Use the format [**BusNumber, SlotNumber**].

To determine the bus number and the PCI slot number, type:

```
tg = slrt;  
getPCIInfo(tg, 'installed')
```

Each time a real-time application containing this driver block is downloaded to the target computer, the board automatically does a full calibration. Thermocouple sensor calibration is an extensive procedure and because it has to take place for each channel independently, the calibration time can easily exceed several seconds, especially when the number of channels to be acquired is 5 or higher. Because of this long calibration period during the initialization stage of the real-time application, the download procedure can time out and return an error message. To avoid this error, increase the default timeout duration. See “Increase the Time for Downloads”.

External Websites

- www.measurementcomputing.com

MIL-STD-1553 Support

- “MIL-STD-1553 Support” on page 43-2
- “MIL-STD-1553 Initialization” on page 43-4
- “Remote Terminal Operation” on page 43-5
- “Bus Controller Operation” on page 43-7
- “Remote Terminal and Bus Controller Operation” on page 43-9
- “Bus Monitor Operation” on page 43-11

MIL-STD-1553 Support

Simulink Real-Time supports the MIL-STD-1553 bus via the PCI-1553, QPCI-1553, QPCX-1553, and Q104 series boards. These boards are manufactured by Abaco, formerly GE Intelligent Platforms, formerly Condor Engineering, see the manufacturer documentation (www.abaco.com). Simulink Real-Time uses the MIL-STD-1553 blocks provided by the MIL-STD-1553 sublibrary of the Simulink Real-Time I/O block library. The sublibrary consists of the following groupings:

- 1553 Utilities — Use these general utility blocks to:
 - Set up Bus Monitor and Bus Controller messages.
 - Create Bus Controller message lists.
 - Encode and decode bus controller messages and status.
- PCI-1553, QPCI-1553, QPCX-1553 — Use these blocks to communicate with the PCI-1553, QPCI-1553, and QPCX-1553 boards, respectively. These blocks enable you to:
 - Initialize a board for Remote Terminal, Bus Controller, and/or Bus Monitor operation.
 - Configure a board for Remote Terminal operation, including Remote Terminal initialization and sending/receiving messages.
 - Configure a board to send Bus Controller messages.

In basic functionality, these board types are the same. The QPC*-1553 boards have additional functionality, such as internal loopback connections and voltage settings.

- Q104-1553 — Use these blocks to communicate with the Q104-1553 boards. These blocks enable you to:
 - Initialize a board for Remote Terminal, Bus Controller, and/or Bus Monitor operation.
 - Configure a board for Remote Terminal operation, including Remote Terminal initialization and sending/receiving messages.
 - Configure a board to send Bus Controller messages.

The QPC* and Q104 boards have almost the same functionality. The Q104 does not support loopback connections and is addressed by PC104 base address instead of by PCI slot.

Regardless of the operation, initialize your board with the Initialize block for the board type you are using—PCI, QPCI, QPCX, or Q104.

MIL-STD-1553 Initialization

The Initialize block allows you to specify the board operation: Remote Terminal, Bus Controller, or Bus Monitor. The mask dialog box for this block changes depending on the operation that you select.

- Select the **Initialize for Bus Controller operation** check box for the Bus Controller.
- Select the **Initialize for Bus Monitor operation** check box for the Bus Monitor.
- Select the **Initialize for Remote Terminal operation** check box for the Remote Terminal.

By default, these check boxes are selected. If you clear an operation check box, the block makes the associated parameters unavailable.

The following is a sample model of how to use the QPCI-1553 Initialize block to initialize channel 1 of a board for Remote Terminal operation. This example and other examples are located in the `xpcdemos` folder. This model:

- Configures two QPCI-1553 Remote Terminal Initialize blocks, one for Remote Terminal 1 and Remote Terminal 5 on that channel.
- Initializes each Remote Terminal with legal sub addresses and legal message lengths for each sub address.

You can configure each sub address for transmit, receive, or both. Configure the sub addresses that you plan to use.

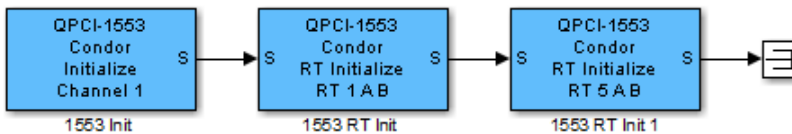

Remote Terminal Operation

The following example uses QPCI-1553 blocks to illustrate how you can configure a Remote Terminal from a Simulink Real-Time model. For standard initialization use the QPCI Initialize block. Use the QPCI RT Initialize block to set up the board for Remote Terminal operation.

You can run this example on a target computer that has a QPCI-1553 board. If your target computer uses a different board, such as a PCI-1553 board, replace the QPCI-1553 blocks with the blocks for your board.

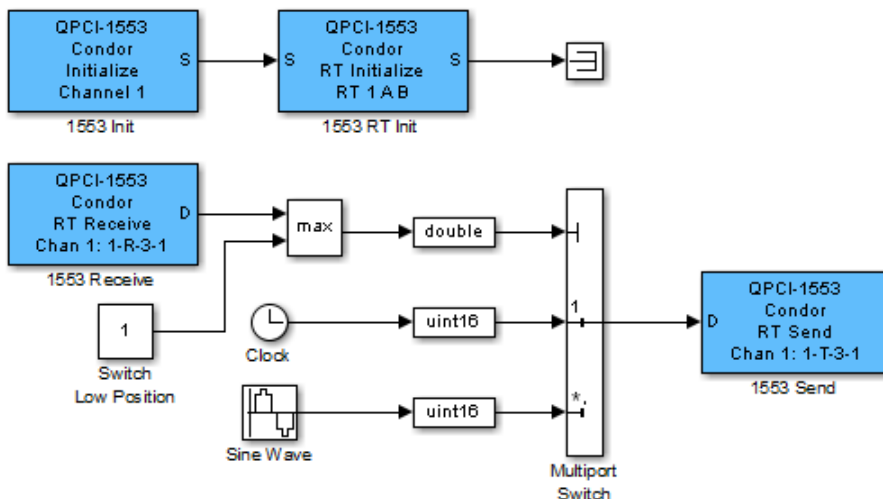

The QPCI-1553 Initialize block configures the board for Remote Terminal operation on channel 1 of the board. The QPCI-1553 RT Initialize block configures the Remote Terminal 1 to monitor buses A and B for incoming messages and configure the active transmit and receive sub addresses. The QPCI-1553 Receive and Send blocks use sub address 3 for both transmit and receive. Note the message parameters notation 1-R-3-1 on the QPCI-1553 Receive and Send blocks. This notation has the format:

remote terminal-R/T-subaddress-number of words

Remote terminal — Indicates the particular Remote Terminal.

R/T — Indicates that the command is for receive (R) or transmit (T).

Subaddress — Indicates the sub address for the message.

Number of words — Indicates the number of 16-bit integers to receive as the data part of a message.

This notation is shorthand that indicates that Remote Terminal 1 is to receive messages on sub address 3 with a length of 1 word. The incoming message consists of one 16-bit integer with a value of 1 or 2. The **Multiport Switch** block uses this input to select either clock or sine wave data.

A QPCI-1553 board has a processor that handles the actual transmission and reception of messages. The QPCI-1553 Receive block reads the board receive message buffer for the specified Remote Terminal and sub address. The QPCI-1553 Send block writes data to the board transmit buffer.

Note: When the board receives a transmit or receive message, it must respond quickly because the default timeout is 14 microseconds. This timeout is much quicker than the ability of the Simulink Real-Time software to reliably execute a model. This situation might cause the board to transmit data from the last time the model executed. Design your model accordingly.

Bus Controller Operation

The example in this topic uses PCI-1553 blocks. It describes how you can use a Bus Controller in a model. This model is a simple example of how to set up a short sequence of two messages, send them, and collect the response data.

You can run this example on a target computer that has a PCI-1553 board. If your target computer uses a different board, such as a QPCI-1553 board, replace the PCI-1553 blocks with the blocks for your board.

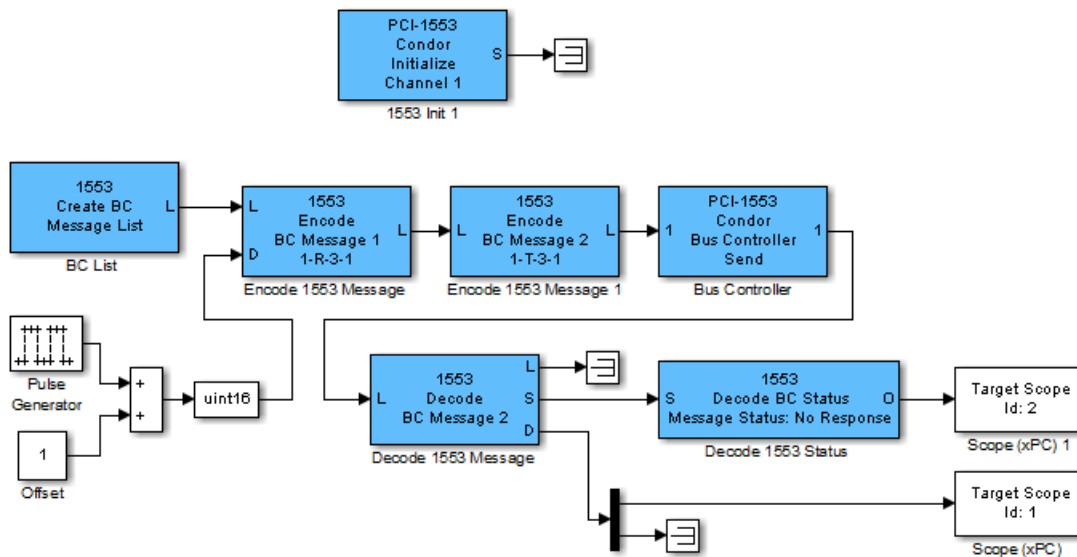

The PCI-1553 Initialize block configures a Bus Controller on channel 1 of the board. This block also tells the board to reserve five message buffers. This number must be at least as large as the longest list of messages that you will send.

The Create BC Message List block allocates an empty list of five message buffers in Simulink Real-Time memory. Each time this block executes, it sets the entire list of message buffers to no-op messages. The Encode BC Message block fills each message for the time step during which the message must be sent. You can also use the Encode BC Message block in an enabled subsystem to send only that message at the specific time that you want the message sent.

The L signal is the message list, a custom data type consisting of a pointer, message length, and special marker. The model passes the L signal through the Encode BC Message blocks. From there, the signal goes to the Bus Controller Send block, executing the Encode blocks before the Send block.

Remote Terminal and Bus Controller Operation

The following example uses PCI blocks. It describes how you can use a Remote Terminal and Bus Controller in a model. This model combines the three models, RTInit, RTSample and BCSample.

RTBCSample runs on a target computer with a multifunction board. It shows how to configure and use a single board as a Bus Controller and Remote Terminal. You can also run this model in one target computer with two different PCI-1553 boards.

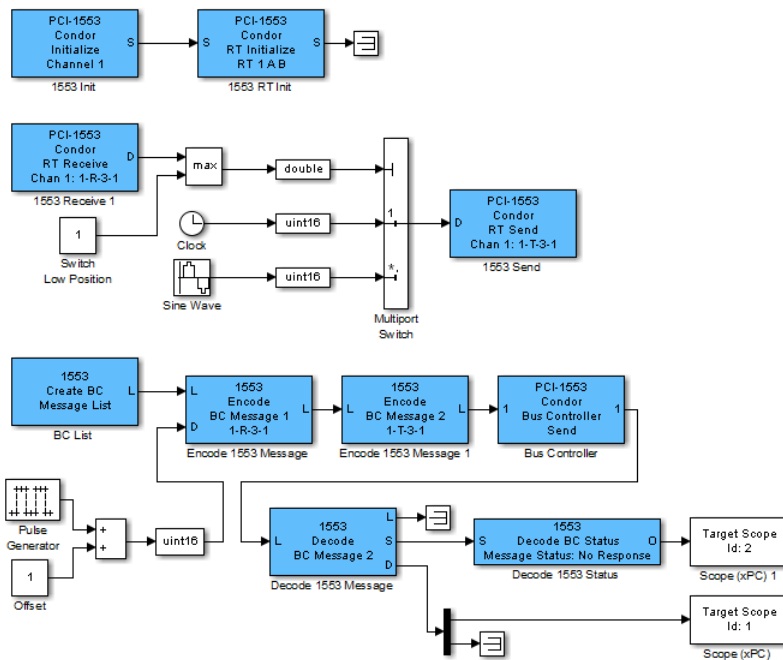

In this example, the two Encode BC Message blocks each create a message, for a total of two, in the list. The message created in the first Encode BC Message block is a receive message. The direction of a message is defined from the point of view of the Remote Terminal. The **Direction** parameter of the block has a value of R (BC->RT). The 1553 Encode BC Message block creates message 1, one 16-bit word, to be sent to Remote Terminal 1, sub address 3. This word has a value of either 1 or 2. This is because the Pulse Generator outputs either 0 or 1, to which a constant value 1 is added.

Message 2 of Bus Controller message list is a command for Remote Terminal 1, sub address 3, to send one word. From the `RTSample` model, that data word comes back containing either the clock or the sine wave data.

The PCI-1553 Bus Controller Send block takes a fully formed list of message buffers and sends it. It waits for the messages to be sent and the response to be received. The PCI-1553 Bus Controller Send block has a programmable maximum wait time parameter (**Maximum wait time (microseconds)**). In this model, the maximum wait time is 1000 microseconds.

The response message list from the PCI-1553 Bus Controller Send block has the same length as the list that was sent. The responses are found in the same position in the list as the corresponding command. In this case, the command to the Remote Terminal to send data is message number 2. The data that is returned is also message number 2 in the response list. In this example, the Decode BC Message block check message 2 only. Decode BC Message blocks can be in arbitrary order on the list. To avoid confusion, put them in numerical order. This example does not check message 1. You can add another Decode BC Message block to check message 1. In this case, only the status is useful because the data is exactly what was sent.

The Decode BC Message block has the following outputs.

- L — Message list passed to other Decode BC Message blocks. If this is the only Decode BC Message block in your model, connect the signal to a terminator or ground.
- S — Status information. The Decode BC Status block extracts individual status bits from this status. To get multiple status bits, use multiple Decode BC Status blocks and feed, in parallel, the same signal to the S ports.
- D — A vector of 32 short integers with the data from that message. Output from the Decode BC Message block has the maximum message width of 32 `uint16` values. The actual message determines how many of these are significant. In this example, only the first value is significant. The block sends the last 31 values to a terminator.

Bus Monitor Operation

The following example uses PCI-1553 blocks. It describes how you can use a Bus Monitor in a model. The Bus Monitor operation outputs a list containing the messages seen on the specified bus since the last time it was called. The `BMSample` model show how to set up a simple bus monitor that looks for the messages in the preceding examples (`RTSample`, `BCSample`, and `RTBCSample`).

You can run this example on a target computer that has a PCI-1553 board. If your target computer uses a different board, such as a QPCI-1553 board, replace the PCI-1553 blocks with the blocks for your board.

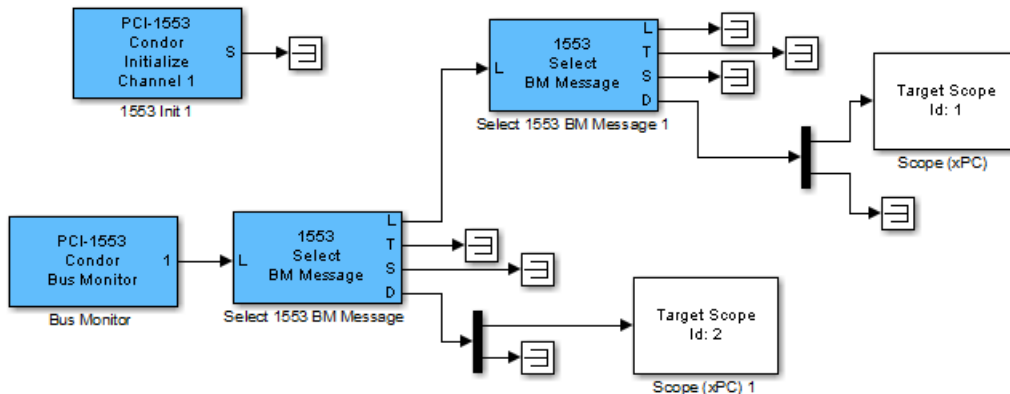

The PCI-1553 Initialize block configures a Bus Monitor on channel 1 of the board. This block also instructs the board to monitor bus A.

The PCI-1553 Bus Monitor block specifies a maximum of 10 messages to receive in a list.

The Select BM Message block picks a message with specified properties out of this list. The Message selection mode parameter of the block provides a finite list of message properties. In this model, the selected property is `BC->RT` or `RT->BC`.

The Select BM Message block has the following outputs:

L — Message list passed to other Select BM Message blocks. If this block is the only Select BM Message block in your model, connect the signal to a terminator or ground.

T — Time that the board believes that the message was received on the bus. This time is the time, in microseconds, since the board was started, presented as a double. The clock might run at a slightly different rate than the model execution timer. This implies that this time is likely different from the Simulink Real-Time execution time.

S — Status information. This information contains seven `uint32` entries with status and command information.

D — A vector of 32 `uint16` entries with the data from that message. This vector outputs 32 entries, even if only some of the entries are defined.

MPL

This topic describes the MPL board supported by the Simulink Real-Time product (www.mpl.ch).

MPL PATI

Support for MPL PATI board.

Board

MPL PATI

General Description

The MPL PowerPC[®] controlled Analog and Timing I/O Intelligence (PATI) has 32 32-bit TPU channels, which the Simulink Real-Time software supports for PWM measurement, PWM generation, time base selection, incremental encoder measurement, and digital I/O. It is based on the Freescale[™] MPC555 processor. The Simulink Real-Time software supports only the TPU channels for this board. The Simulink Real-Time block library supports the MPL PATI board with these driver blocks:

The Simulink Real-Time block library supports this board with these driver blocks:

- MPL PATI Digital Input
- MPL PATI Digital Output
- MPL PATI Incremental Encoder
- MPL PATI PWM generate
- MPL PATI PWM measure
- MPL PATI Timebase Setup
- MPL PATI EEPROM Write

When installing MPL PATI boards, note the following slot selection configuration settings. In the following, the first number after the S indicates the switch number (1) and the second number indicates the switch.

- S1-1 and S1-2 — Select the stacking position in which the board is found. Use the following settings:
 - First board: S1-1 — off, S1-2 — off
 - Second board: S1-1 — on, S1-2 — off

- Third board: S1-1 — off, S1-2 — on
- Fourth board: S1-1 — on, S1-2 — on
- S3 — off
- S4 — on (enable restart)
- S5 — off
- S6 — off
- S7 — off
- S8 — off

See the MPL PATI user documentation for a description of the DIP switch S1. For some target computer CPU boards, you might be limited to two PC/104+ boards, for others, you might be able to add up to four PC/104+ boards.

Board Characteristics

Board name	MPL PATI
Manufacturer	MPL
Bus type	PC/104
Multiple block instance support	Yes
Multiple board support	Yes

External Websites

- www.mpl.ch

MPL PATI Digital Input

MPL PATI Digital Input block

Library

Simulink Real-Time Library for MPL

General Description

The individual bits of the MPL PATI digital input are in different registers. As a result, you cannot read multiple bits at the same time. To emphasize this, you must use a separate MPL PATI Digital Input block to read each bit.

Note: To execute a model using this block, you must first write MPL boot code on the EEPROM using the MPL PATI EEPROM Write block.

To flash the EEPROM with the boot code, add the EEPROM Write block to an empty model, then build and execute that model before executing the actual model. See MPL PATI EEPROM Write block for further information.

Block Parameters

Channel

From the list, select from 1 to 32. This is the single TPU channel that this block reads.

Channel priority

From the list, select **Low**, **Medium**, or **High** priority. This changes the order that individual timers are serviced. See the MPC555 TPU documentation for more information.

Sample time

Enter the base sample time or a multiple of the base sample time (-1 means sample time is inherited).

PCI slot

If only one board of this type is in the target computer, enter -1 to locate the board.

If two or more boards of this type are in the target computer, enter the bus number and the PCI slot number of the board associated with this driver block. Use the format **[BusNumber,SlotNumber]**. To determine the bus number and the PCI slot number, type:

```
tg = slrt;  
getPCIInfo(tg, 'installed')
```

External Websites

- www.mpl.ch

MPL PATI Digital Output

MPL PATI Digital Output block

Library

Simulink Real-Time Library for MPL

General Description

The individual bits of the MPL PATI digital output are in different registers. As a result, you cannot update multiple digital outputs at the same time. To emphasize this, you must use a separate MPL PATI Digital Output block to control each bit.

Note: To execute a model using this block, you must first write MPL boot code on the EEPROM using the MPL PATI EEPROM Write block.

To flash the EEPROM with the boot code, add the EEPROM Write block to an empty model, then build and execute that model before executing the actual model. See MPL PATI EEPROM Write block for further information.

Block Parameters

Channel

From the list, select from 1 to 32. This is the single TPU channel that this block controls.

Channel priority

From the list, select **Low**, **Medium**, or **High** priority. This changes the order that individual timers are serviced. See the MPC555 TPU documentation for more information.

Reset

This parameter controls the behavior of the bit at model termination. Enter one of the following values:

- 1

Resets the output bit to the value in **Initial Value**.

- 0

Leaves the output bit at the most recent value attained while the model was running.

Initial value

Enter the initial voltage value for the output bit. The output bit is set to this value between the time the model is downloaded and the time the model is started. Also, if the **Reset** parameter has a value of 1, the output bit is reset to the initial value when the model is stopped.

Sample time

Enter the base sample time or a multiple of the base sample time (- 1 means sample time is inherited).

PCI slot

If only one board of this type is in the target computer, enter - 1 to locate the board.

If two or more boards of this type are in the target computer, enter the bus number and the PCI slot number of the board associated with this driver block. Use the format **[BusNumber, SlotNumber]**. To determine the bus number and the PCI slot number, type:

```
tg = slrt;  
getPCIInfo(tg, 'installed')
```

External Websites

- www.mpl.ch

MPL PATI Incremental Encoder

MPL PATI Incremental Encoder block

Library

Simulink Real-Time Library for MPL

General Description

This block has one input port and one output port.

- Input port

Selects the counting mode. The block M input port determines the counting mode. The incremental encoder function has two counting modes, normal and fast. In fast mode, the count direction is not controlled by the polarity of the two signals but continues the same direction that was determined when the counter was last in normal mode. The maximum counting rate is much higher in fast mode than in normal mode.

- Normal mode

If the block input M is less than 0.5, the counter works in normal mode and counts on each edge. The edge sense and polarity of each signal determines the count direction of each signal. Each rising and falling edge of both inputs is counted. You must set the counting mode to normal when the model is first started. You can change it to fast mode afterward.

- Fast mode

If the block input M is greater than or equal to 0.5, the counter works in fast mode. The counter increments by 4 each time the primary channel has a rising edge.

- Output port

Returns the current position count as a double.

To keep the counting mode set to normal mode, just connect a constant block with the value 0 to the M input.

Note: To execute a model using this block, you must first write MPL boot code on the EEPROM using the MPL PATI EEPROM Write block.

To flash the EEPROM with the boot code, add the EEPROM Write block to an empty model, then build and execute that model before executing the actual model. See MPL PATI EEPROM Write block for further information.

Block Parameters

Channel pair

From the list, choose a pair of sequential channels for the incremental encoder. Both channels must be in the same group of 16. For example, 1+2, 2+3, or 18+19. If you want to use channels 16 or 32, their sequential partners are 1 and 17, for example, 16+1 and 32+17.

Channel priority

From the list, select Low, Medium, or High priority. This changes the order that individual timers are serviced. See the MPC555 TPU documentation for more information.

Initial count

The initial count specifies the initial value for the encoder count register when the model starts executing.

Output range

From the list, choose one of the following. This block converts the output to doubles.

- signed [-32768 +32767]

Interprets the 16-bit count as a signed quantity. This places the discontinuity far from the 0 origin. Counting up from 32767 goes to -32768 on the next count.

- unsigned [0 65535]

Interprets the 16-bit count as an unsigned quantity. This places the discontinuity at the origin, where counting up from 65535 goes to 0 on the next count.

Sample time

Enter the base sample time or a multiple of the base sample time (-1 means sample time is inherited).

PCI slot

If only one board of this type is in the target computer, enter - 1 to locate the board.

If two or more boards of this type are in the target computer, enter the bus number and the PCI slot number of the board associated with this driver block. Use the format **[BusNumber,SlotNumber]**. To determine the bus number and the PCI slot number, type:

```
tg = slrt;  
getPCIInfo(tg, 'installed')
```

External Websites

- www.mpl.ch

MPL PATI PWM generate

MPL PATI PWM generate block

Library

Simulink Real-Time Library for MPL

Scaling Output to Input

I/O Module Output	Block Input Data Type	Scaling
0 to 5 volts	Double	Counts

General Description

This block uses the PWM module in the time processor units (TPUs) on the board to generate rectangular wave output. See the MPC555 documentation from Freescale Semiconductor at www.freescale.com for more information on the PWM module.

This block has three inputs:

- **H** — Number of counts of the chosen time base that the output should remain high. You can use a count from 0 to 32767. With the use of multiple channels, you might not be able to get your output to 0 width smoothly. If you have a small number of channels, you can try to use the channel **Priority** parameter to more smoothly approach 0 width.
- **L** — Number of counts of the chosen time base that the output should remain low. Range from 0 to 32767. With the use of multiple channels, you might not be able to smoothly get your output to 0 width. If you have a small number of channels, you can try to use the channel **Priority** parameter to more approach 0 width smoothly.
- **A** — Specifies whether or not the output is to be armed. If the A input is 0, the block stops the output and the output level is the one chosen in the dialog. If A is 1, the output runs. This port does not appear if you do not select **Arm input**.

Note: To execute a model using this block, you must first write MPL boot code on the EEPROM using the MPL PATI EEPROM Write block.

To flash the EEPROM with the boot code, add the EEPROM Write block to an empty model, then build and execute that model before executing the actual model. See MPL PATI EEPROM Write block for further information.

Limitations

If you use multiple blocks for different channels, the relative timing between the output signals is not controlled and is not repeatable on the order of a few 10s of microseconds even if the output frequency is the same.

Block Parameters

Channel

From the list, select a channel from 1 to 32. This board has two TPUs. Channels 1 through 16 are on the first TPU, channels 17 through 32 are on the second TPU. The channel you select works with the **Timebase** parameter.

Priority

From the list, select **Low**, **Medium**, or **High** priority. This changes the order that individual timers are serviced. See the MPC555 TPU documentation for more information.

Initial high count

Enter the high count to be used from initialization until the model is running.

Initial low count

Enter the low count to be used from initialization until the model is running.

Immediate update

Select this check box to force the output to use the new count immediately. Selecting this check box can result in very short output pulses. It terminates long pulses immediately.

Clear this check box to allow the current output cycle to finish before the update. Clearing this check box generates smoother frequency and phase transitions without transients.

The block does not interrupt long pulses. Note that your selection of this parameter value depends on your system requirements.

Arm input

Select this check box to indicate that the ARM input is present. If this check box is selected, the channel behaves as follows. Note that there might be a delay, on the order of the output period, between the time that the ARM input becomes 1 and the output port starts changing.

- If the input signal to this port is 1, the channel outputs the signal specified by the H and L ports.
- If the input signal to this port is 0, the output stops at the level specified by the **Disarm state** drop-down list.

If you do not select this check box, the block behaves as if the ARM input is 1. Input port A does not appear.

Disarm state

From the drop-down list, select

- Disarm to LOW
- Disarm to HIGH

When the ARM input is 0, this parameter specifies the state of the output.

State on model stop

From the drop-down list, select

- Leave running

Continue to get output pulses at the last H and L port values.

- Stop to LOW

Immediately go to the LOW output state and maintain that level.

- Stop to HIGH

Immediately go to the HIGH output state and maintain that level.

Timebase

From the list, select TCR1 or TCR2. This depends on the MPL PATI Timebase Setup settings. If you do not use the MPL PATI Timebase Setup block, the TCR1 time base defaults to 1.25 MHz.

Sample time

Enter the base sample time or a multiple of the base sample time (- 1 means sample time is inherited).

PCI slot

If only one board of this type is in the target computer, enter - 1 to locate the board.

If two or more boards of this type are in the target computer, enter the bus number and the PCI slot number of the board associated with this driver block. Use the format **[BusNumber, SlotNumber]**. To determine the bus number and the PCI slot number, type:

```
tg = slrt;  
getPCIInfo(tg, 'installed')
```

See Also

MPL PATI Timebase Setup

External Websites

- www.mpl.ch

MPL PATI PWM measure

MPL PATI PWM measure

Library

Simulink Real-Time Library for MPL

Scaling Input to Output

I/O Module Input	Block Output Data Type	Scaling
0 to 5 volts	Double	Counts of current time base

General Description

This block uses the PTA module in the time processor units (TPUs) on the board to measure full cycle period or high or low time in an input waveform. To use the TPUs, you must condition the TPU inputs with a voltage between 0 and 5 volts. The inputs also must have a reasonably fast rise or fall time; otherwise, false triggering might occur. The inputs use TTL level transitions. See the MPC555 documentation from Freescale Semiconductor at www.freescale.com for more information on the PTA module. This block outputs the number of counts of the input time base (default 20 MHz, configurable in the MPL PATI Timebase Setup block) that meet the mode chosen.

Note: To execute a model using this block, you must first write MPL boot code on the EEPROM using the MPL PATI EEPROM Write block.

To flash the EEPROM with the boot code, add the EEPROM Write block to an empty model, then build and execute that model before executing the actual model. See MPL PATI EEPROM Write block for further information.

Block Parameters

Channel

From the list, select a channel from 1 to 32. This board has two TPUs. Channels 1 through 16 are on the first TPU, channels 17 through 32 are on the second TPU. The channel you select works with the time base parameter.

Channel priority

From the list, select **Low**, **Medium**, or **High** priority. This changes the order that individual timers are serviced. See the MPC555 TPU documentation for more information.

Mode

From the list, select

- **Total High Time** — For measuring pulse widths
- **Total Low Time** — For measuring pulse widths
- **Between Rising Edges** — For period measurements
- **Between Falling Edges** — For period measurements

Number of periods to count

Enter the number of periods to count. To measure every cycle separately, enter a value of 1 (default). To get higher precision by averaging, enter a higher value, then divide the block output by this value. For example, to gain a period with a precision of 0.1 count, enter a value of 10 for this count, then divide the block output by 10.

Timebase

From the list, select TCR1 or TCR2. This depends on the **MPL PATI Timebase Setup** settings. If you do not use the **MPL PATI Timebase Setup** block, the TCR1 time base defaults to 1.25 MHz.

Sample time

Enter the base sample time or a multiple of the base sample time (- 1 means sample time is inherited).

PCI slot

If only one board of this type is in the target computer, enter - 1 to locate the board.

If two or more boards of this type are in the target computer, enter the bus number and the PCI slot number of the board associated with this driver block. Use the format **[BusNumber, SlotNumber]**. To determine the bus number and the PCI slot number, type:

```
tg = slrt;
```

```
getPCIInfo(tg, 'installed')
```

See Also

MPL PATI Timebase Setup

External Websites

- www.mpl.ch

MPL PATI Timebase Setup

MPL PATI Timebase Setup block

Library

Simulink Real-Time Library for MPL

General Description

The Freescale MPC555 processor contains two time processor units (TPUs). Each TPU has 16 timer channels (1 to 16 and 17 to 32), totaling 32 channels, for one MPL PATI board. Each TPU has two time bases (four between the two TPUs) that can be used in the timer functions. The basic frequency for the TPU is the clock frequency for the CPU, (40 MHz). The minimum divider that can be applied is a factor of 2, which gives the maximum timer frequency of 20 MHz. This block allows you to set the frequency for each of the four time bases, two time bases for channels 1 to 16 and two for channels 17 to 32.

Each TPU allows two different timer sources called TCR1 and TCR2.

- TCR1 is driven by a clock source with a frequency of $40 \text{ MHz}/N$, where N is a power of 2 between 2 and 512.
- TCR2 can be driven either by an external clock source or by a clock source with a frequency of $40 \text{ MHz}/N$, where N is a power of 2 between 8 and 32. Note that the MPL PATI user documentation refers to the channel's 17 to 32 external input as TPU_T2CLKB.

The I/O module architecture restricts allowable values for the time bases. See the MPC555 documentation from Freescale Semiconductor at www.freescale.com for more information on the TPUs and time bases.

Note: To execute a model using this block, you must first write MPL boot code on the EEPROM using the MPL PATI EEPROM Write block.

To flash the EEPROM with the boot code, add the EEPROM Write block to an empty model, then build and execute that model before executing the actual model. See MPL PATI EEPROM Write block for further information.

Block Parameters

TCR1 divider (1–16)

From the list, choose the divider that sets the TCR1 time base for channels 1 to 16. The minimum divider of 2 gives the maximum time base frequency of 20 MHz. The maximum divider of 512 gives a time base frequency of 78.125 kHz.

TCR2 divider (1–16)

From the list, choose one of the following:

- 8 (5 Mhz) or ext
- 16 (2.5 Mhz) or ext/2
- 32 (1.25 Mhz) or ext/4
- 64 (625 Khz) or ext/8

This divider sets the TCR2 time base for channels 1 to 16. You can specify that the TCR2 time base can be driven by either the 40 MHz CPU clock or by a signal on the external T2CLK input pin. Note that the maximum frequency of the external signal is approximately $40 \text{ MHz}/9 = 4.44 \text{ MHz}$.

If you want to use the external clock, select the **TCR2 external clock input (1–16)** check box.

TCR2 external clock input (1–16)

Select this check box to use the signal on the T2CLK pin as the source for TCR2. Use this parameter with the **TCR2 divider (1–16)** parameter.

TCR1 divider (17–32)

From the list, choose the divider that sets the TCR1 time base for channels 17 to 32. A minimum divider of 2 gives the maximum time base frequency of 20 MHz. A maximum divider of 512 gives a time base frequency of 78.125 kHz.

TCR2 divider (17–32)

From the list, choose one of the following:

- 8 (5 Mhz) or ext
- 16 (2.5 Mhz) or ext/2
- 32 (1.25 Mhz) or ext/4
- 64 (625 Khz) or ext/8

This divider sets the TCR2 time base for channels 1 to 16. You can specify that the TCR2 time base can be driven by either the 40 MHz CPU clock or by a signal on the external T2CLK input pin. Note that the maximum frequency of the external signal is approximately $40 \text{ MHz}/9 = 4.44 \text{ MHz}$.

If you want to use the external clock, select the **TCR2 external clock input (17-32)** check box.

TCR2 external clock (17-32)

Select this check box to use the signal on the T2CLK pin as the source for TCR2. Use this parameter with the **TCR2 divider (17-32)** parameter.

PCI slot

If only one board of this type is in the target computer, enter - 1 to locate the board.

If two or more boards of this type are in the target computer, enter the bus number and the PCI slot number of the board associated with this driver block. Use the format **[BusNumber,SlotNumber]**. To determine the bus number and the PCI slot number, type:

```
tg = slrt;  
getPCIInfo(tg, 'installed')
```

External Websites

- www.mpl.ch

MPL PATI EEPROM Write

MPL PATI EEPROM Write

Library

Simulink Real-Time Library for MPL

General Description

The `MPL PATI EEPROM Write` block writes MPL boot code on the EEPROM. Before executing a Simulink Real-Time model that contains an MPL PATI block, you must first write MPL boot code on the EEPROM using the `MPL PATI EEPROM Write` block.

You must use this block by itself in an empty model to re-flash the EEPROM. Be sure to run this model only once to write the boot code on the EEPROM. You must restart the target computer before executing the actual model. Do not include this block in another model.

To flash the EEPROM with the boot code:

- 1 Add the `MPL PATI EEPROM Write` block to an empty model. To access the library that contains this block, type `xpcmpllib`.
- 2 Build and execute this model. The work is completed when the model is downloaded to the target computer.
- 3 Reboot the target computer.
- 4 Build and execute your actual model.

Block Parameters

PCI slot

If only one board of this type is in the target computer, enter `-1` to locate the board.

If two or more boards of this type are in the target computer, enter the bus number and the PCI slot number of the board associated with this driver block. Use the

format **[BusNumber,SlotNumber]**. To determine the bus number and the PCI slot number, type:

```
tg = slrt;  
getPCIInfo(tg, 'installed')
```

External Websites

- www.mpl.ch

National Instruments

National Instruments Support

This topic describes National Instruments I/O boards supported by the Simulink Real-Time product (www.ni.com).

National Instruments Troubleshooting

First count for the PCI 6602 Event Counter block — If the input signal that you are measuring is high and the gate is set to high, the initial count is not correct. This behavior is expected.

Before simulation starts, the counter hardware resets. If the signal that you are measuring is high, the counter gate condition is satisfied. The counter starts and counts for an unknown amount of time until the first time step. After the counter resets, each subsequent read occurs within one time step.

National Instruments Blocks

This topic describes National Instruments I/O boards supported by the Simulink Real-Time product (www.ni.com).

National Instruments PCI-6011E (formerly PCI-MIO-16XE-50)

Support for National Instruments PCI-6011E board

Board

National Instruments PCI-6011E

General Description

This board was formerly PCI-MIO-16XE-50.

The PCI-6011E is an I/O board with 16 single or 8 differential analog input (A/D) channels (16-bit) with a maximum sample rate of 100 kHz, 2 analog output (D/A) channels (12-bit), 8 digital input and output lines, and 2 counter/timers (24-bit) with a maximum source clock rate of 20 MHz.

The Simulink Real-Time block library supports this board with these driver blocks:

- National Instruments PCI-6011E Analog Input (A/D) (formerly PCI-MIO-16XE-50)
- National Instruments PCI-6011E Analog Output (D/A) (formerly PCI-MIO-16XE-50)
- National Instruments PCI-6011E Digital Input (formerly PCI-MIO-16XE-50)
- National Instruments PCI-6011E Digital Output (formerly PCI-MIO-16XE-50)
- National Instruments PCI-6011E Pulse Generation (formerly PCI-MIO-16XE-50)
- National Instruments PCI-6011E Pulse Width/Period Measurement (formerly PCI-MIO-16XE-50)

Board Characteristics

Board name	PCI-6011E
Manufacturer	National Instruments
Bus type	PCI

Access method

I/O mapped

Multiple block instance support

A/D: No, D/A: No, Digital I/O: Yes; Pulse
Width/Period measurement: Yes; Pulse
Train Generation: No

Multiple board support

Yes

External Websites

- www.ni.com

National Instruments PCI-6011E Analog Input (A/D) (formerly PCI-MIO-16XE-50)

PCI-6011E Analog Input block

Library

Simulink Real-Time Library for National Instruments

Scaling of Input to Output

I/O Module Input	Block Output Data Type	Scaling
Volts	Double	1

Block Parameters

Channel vector

Enter numbers between 1 and 16. This driver allows you to enter channel numbers in arbitrary order.

For example, to use the first, second, and fifth channels, enter

```
[1,2,5]
```

Number the channels beginning with 1, even if this board manufacturer starts numbering the channels with 0.

Range vector

Enter a range code for each channel in the channel vector. The range vector must be the same length as the channel vector. This driver allows each channel to be different.

The following table lists the ranges for this driver and the corresponding range codes.

Input Range (V)	Range Code
-10 to +10	-10
-5 to +5	-5
-1 to +1	-1
-0.1 to +0.1	-0.1
0 to +10	10
0 to +5	5
0 to +1	1
0 to +0.1	0.1

For example, if the first channel is -10 to +10 volts and the second and fifth channels are 0 to +1 volts, enter

`[-10,1,1]`

Input coupling vector

Enter a coupling code for each channel in the channel vector. The coupling vector must be the same length as the channel vector. This driver allows a different coupling for each channel.

The following table lists the couplings for this driver and the corresponding coupling codes.

Coupling	Coupling Code	Description
RSE	0	Analog input line connected to the positive input of the PGIA. Analog input ground (AIGND) internally connected to the negative input of the PGIA. See the board manual.
NRSE	1	Analog input line connected to the positive input of the PGIA. Analog input sense (AISENSE) connected to the negative input of the PGIA. See the board manual.
DIFF	2	First analog input line connected to the positive input of the PGIA. Second analog input line connected to the negative input of the PGIA. See the board manual.

For example, if the first and second channels are single input and the fifth channel is a differential input, enter

```
[0,0,2]
```

The driver selects a second differential input eight channels higher than the first channel. In the example above, the driver would select the thirteenth channel as a differential input with the fifth channel.

If the board is set up for differential mode, you can read the data from either of the channels in the differential pair. For example, if you have a differential pair of 1 and 9, you can read the data from channel 1 or channel 9. However, you might want to read the lower channel number of the pair because it remains unchanged when you switch the input mode between single-ended and differential.

Sample time

Enter the base sample time or a multiple of the base sample time (- 1 means sample time is inherited).

PCI slot (-1:autosearch)

If only one board of this type is in the target computer, enter - 1 to locate the board.

If two or more boards of this type are in the target computer, enter the bus number and the PCI slot number of the board associated with this driver block. Use the format **[BusNumber,SlotNumber]**.

To determine the bus number and the PCI slot number, type:

```
tg = slrt;  
getPCIInfo(tg, 'installed')
```

External Websites

- www.ni.com

National Instruments PCI-6011E Analog Output (D/A) (formerly PCI-MIO-16XE-50)

PCI-6011E Analog Output block

Library

Simulink Real-Time Library for National Instruments

Note

The analog output range of this board is set -10 to +10 volts.

Scaling of Input to Output

I/O Module Output	Block Input Data Type	Scaling
Volts	Double	1

Block Parameters

Channel vector

Enter 1 or 2. This driver allows the selection of individual D/A channels in arbitrary order. The number of elements defines the number of D/A channels used. For example, to use both of the analog output channels, enter

[1,2]

Number the channels begin with 1 even if this board manufacturer starts numbering the channels with 0.

Reset vector

The reset vector controls the behavior of the channel at model termination. Enter a scalar or a vector that is the same length as the channel vector. If you specify a scalar

value, that setting is replicated over the channel vector. If you specify a value of 1, the corresponding channel is reset to the value specified in the initial value vector. If you specify a value of 0, the channel remains at the last value attained while the model was running.

Initial value vector

The initial value vector contains the initial voltage values for the output channels. Enter a scalar or a vector that is the same length as the channel vector. If you specify a scalar value, that value is replicated as the initial value over the channel vector. The channels are set to the initial values between the time the model is downloaded and the time it is started.

Sample time

Enter the base sample time or a multiple of the base sample time (- 1 means sample time is inherited).

PCI slot (-1:autosearch)

If only one board of this type is in the target computer, enter - 1 to locate the board.

If two or more boards of this type are in the target computer, enter the bus number and the PCI slot number of the board associated with this driver block. Use the format **[BusNumber, SlotNumber]**.

To determine the bus number and the PCI slot number, type:

```
tg = slrt;  
getPCIInfo(tg, 'installed')
```

External Websites

- www.ni.com

National Instruments PCI-6011E Digital Input (formerly PCI-MIO-16XE-50)

PCI-6011E Digital Input block

Library

Simulink Real-Time Library for National Instruments

Scaling of Input to Output

I/O Module Input	Block Output Data Type	Scaling
TTL	Double	TTL low = 0.0 TTL high = 1.0

Block Parameters

Channel vector

Enter numbers between 1 and 8 to select the digital input lines used with this port. This driver allows the selection of individual digital input lines in arbitrary order. The number of elements defines the number of digital lines used.

For example, to use all of the digital inputs for one port, enter

```
[1,2,3,4,5,6,7,8]
```

Number the lines beginning with 1 even if this board manufacturer starts numbering the lines with 0.

Sample time

Enter the base sample time or a multiple of the base sample time (-1 means sample time is inherited).

PCI slot (-1:autosearch)

If only one board of this type is in the target computer, enter -1 to locate the board.

If two or more boards of this type are in the target computer, enter the bus number and the PCI slot number of the board associated with this driver block. Use the format **[BusNumber,SlotNumber]**.

To determine the bus number and the PCI slot number, type:

```
tg = slrt;  
getPCIInfo(tg, 'installed')
```

External Websites

- www.ni.com

National Instruments PCI-6011E Digital Output (formerly PCI-MIO-16XE-50)

PCI-6011E Digital Output block

Library

Simulink Real-Time Library for National Instruments

Scaling of Input to Output

I/O Module Output	Block Input Data Type	Scaling
TTL	Double	$< 0.5 = \text{TTL low}$ $\geq 0.5 = \text{TTL high}$

Block Parameters

Channel vector

Enter numbers between 1 and 8 to select the digital output lines used with this port. This driver allows the selection of individual digital output lines in arbitrary order. The number of elements defines the number of digital lines used.

For example, to use all of the digital outputs for one port, enter

```
[1,2,3,4,5,6,7,8]
```

Number the lines beginning with 1 even if this board manufacturer starts numbering the lines with 0.

Reset vector

The reset vector controls the behavior of the channel at model termination. Enter a scalar or a vector that is the same length as the channel vector. If you specify a scalar value, that setting is replicated over the channel vector. If you specify a value of 1, the corresponding channel is reset to the value specified in the initial value vector.

If you specify a value of 0, the channel remains at the last value attained while the model was running.

Initial value vector

The initial value vector contains the initial values (0 or 1) of the output channels. Enter a scalar or a vector that is the same length as the channel vector. If you enter a scalar, that value is replicated as the initial value over the channel vector. The channels are set to these initial values between the time the model is downloaded and the time it is started.

Sample time

Enter the base sample time or a multiple of the base sample time (- 1 means sample time is inherited).

PCI slot (-1:autosearch)

If only one board of this type is in the target computer, enter - 1 to locate the board.

If two or more boards of this type are in the target computer, enter the bus number and the PCI slot number of the board associated with this driver block. Use the format **[BusNumber, SlotNumber]**.

To determine the bus number and the PCI slot number, type:

```
tg = slrt;  
getPCIInfo(tg, 'installed')
```

External Websites

- www.ni.com

National Instruments PCI-6011E Pulse Generation (formerly PCI-MIO-16XE-50)

PCI-6011E Pulse Generation block

Library

Simulink Real-Time Library for National Instruments

Requirements

The inputs to the block should be a two-element vector. The first element is the number of counts (of the 20 MHz source clock) that the counter should maintain at a low level, and the second element is the number of clock ticks for a high level. For example, to generate a pulse train at 1 kHz with 25% low and 75% high, use the vector

```
[5000 15000]
```

Block Parameters

Counter

From the list, choose **Counter 0**, **Counter 1**, or **Both** to select the counter(s) to be used with this driver block. In each case, one block is required for each physical board.

Sample time

Enter the base sample time or a multiple of the base sample time (-1 means sample time is inherited).

PCI slot (-1:autosearch)

If only one board of this type is in the target computer, enter -1 to locate the board.

If two or more boards of this type are in the target computer, enter the bus number and the PCI slot number of the board associated with this driver block. Use the format **[BusNumber, SlotNumber]**.

To determine the bus number and the PCI slot number, type:

```
tg = slrt;  
getPCIInfo(tg, 'installed')
```

External Websites

- www.ni.com

National Instruments PCI-6011E Pulse Width/Period Measurement (formerly PCI-MIO-16XE-50)

PCI-6011E Pulse Width/Period Measurement

Library

Simulink Real-Time Library for National Instruments

Note

Connect the signal you want to measure to the GATE input of the chosen counter. The signal must have fast rise and fall times; otherwise, the counter might experience false triggering. Use signal voltage levels between 0 and 5 volts (TTL levels).

Block Parameters

Counter

From the list, select a counter, 0 or 1.

Trigger mode

From the list, choose **Level Triggered** or **Edge Triggered**. See the table below for an example of how **Trigger mode** and **Polarity** interact. In this table, the data in the Output column resulted from a 1 kHz pulse train with a 25% low and a 75% high pulse.

Polarity

From the list, choose **Active low** or **Active high**. See the table below for an example of how **Trigger mode** and **Polarity** interact. In this table, the data in the Output column resulted from a 1 kHz pulse train with a 25% low and a 75% high pulse.

Measurement Objective	Trigger Mode	Polarity	Output
Pulse width (low pulse)	Level triggered	Active low	5000

Measurement Objective	Trigger Mode	Polarity	Output
Pulse width (high pulse)	Level triggered	Active high	15000
Period	Edge triggered	NA	20000

In every case, the output of the block is the number of clock ticks (of the 20 MHz source clock) required for the specified measurement. When measuring pulse width, the output reflects the number of clock ticks for which the input signal was in the specified (low or high) state. See the table above for an example.

Sample time

Enter the base sample time or a multiple of the base sample time (- 1 means sample time is inherited).

PCI slot (-1:autosearch)

If only one board of this type is in the target computer, enter - 1 to locate the board.

If two or more boards of this type are in the target computer, enter the bus number and the PCI slot number of the board associated with this driver block. Use the format **[BusNumber,SlotNumber]**.

To determine the bus number and the PCI slot number, type:

```
tg = slrt;
getPCIInfo(tg, 'installed')
```

External Websites

- www.ni.com

National Instruments PCI-6023E

Support for National Instruments PCI-6023E board

Board

National Instruments PCI-6023E

General Description

The PCI-6023E is an I/O board with 16 single or 8 differential analog input (A/D) channels (12-bit) with a maximum sample rate of 200 kHz, 8 digital I/O lines, and 2 counter/timers (24-bit) with a maximum source clock rate of 20 MHz.

The Simulink Real-Time block library supports this board with these driver blocks:

- National Instruments PCI-6023E Analog Input (A/D)
- National Instruments PCI-6023E Digital Input
- National Instruments PCI-6023E Digital Output
- National Instruments PCI-6023E Pulse Generation
- National Instruments PCI-6023E Pulse Width/Period Measurement

Board Characteristics

Board name	PCI-6023E
Manufacturer	National Instruments
Bus type	PCI
Access method	Memory mapped
Multiple block instance support	A/D: No, Digital I/O: Yes; Pulse Width/Period Measurement: Yes; Pulse Train Generation: No.
Multiple board support	Yes

External Websites

- www.ni.com

National Instruments PCI-6023E Analog Input (A/D)

PCI-6023E Analog Input block

Library

Simulink Real-Time Library for National Instruments

Scaling Input to Output

I/O Module Input	Block Output Data Type	Scaling
Volts	Double	1

Block Parameters

Channel vector

Enter numbers between 1 and 16. This driver allows you to enter channel numbers in arbitrary order.

For example, to use the first, second, and fifth channels, enter

[1,2,5]

Number the channels beginning with 1 even if this board manufacturer starts numbering the channels with 0.

Range vector

Enter a range code for each of the channels in the channel vector. The range vector must be the same length as the channel vector. This driver allows each channel to be different.

The following table is a list of the ranges for this driver and the corresponding range codes.

Input Range (V)	Range Code
-10 to +10	-10

Input Range (V)	Range Code
-5 to +5	-5
-0.5 to +0.5	-0.5
-0.05 to +0.05	-0.05

For example, if the first channel is -10 to +10 volts and the second and fifth channels are -5 to +5 volts, enter

[-10, -5, -5]

Input coupling vector

Enter a coupling code for each of the channels in the channel vector. The coupling vector must be the same length as the channel vector. This driver allows a different coupling for each channel.

The following table is a list of the couplings for this driver and the corresponding coupling codes.

Coupling	Coupling Code	Description
RSE	0	Analog input line connected to the positive input of the PGIA. Analog input ground (AIGND) internally connected to the negative input of the PGIA. See the board manual.
NRSE	1	Analog input line connected to the positive input of the PGIA. Analog input sense (AISENSE) connected to the negative input of the PGIA. See the board manual.
DIFF	2	First analog input line connected to the positive input of the PGIA. Second analog input line connected to the negative input of the PGIA. See the board manual.

For example, if the first and second channels are single input and the fifth channel is a differential input, enter

[0,0,2]

The driver selects a second differential input 8 channels higher than the first channel. In the example above, the driver would select the thirteenth channel as a differential input with the fifth channel.

If the board is set up for differential mode, you can read the data from either of the channels in the differential pair. For example, if you have a differential pair of 1 and 9, you can read the data from channel 1 or channel 9. However, you might want to read the lower channel number of the pair because it remains unchanged when you switch the input mode between single-ended and differential.

Sample time

Enter the base sample time or a multiple of the base sample time (- 1 means sample time is inherited).

PCI slot (-1:autosearch)

If only one board of this type is in the target computer, enter - 1 to locate the board.

If two or more boards of this type are in the target computer, enter the bus number and the PCI slot number of the board associated with this driver block. Use the format [**BusNumber**,**SlotNumber**].

To determine the bus number and the PCI slot number, type:

```
tg = slrt;  
getPCIInfo(tg, 'installed')
```

External Websites

- www.ni.com

National Instruments PCI-6023E Digital Input

PCI-6023E Digital Input

Library

Simulink Real-Time Library for National Instruments

Scaling Input to Output

I/O Module Input	Block Output Data Type	Scaling
TTL	Double	TTL low = 0.0 TTL high = 1.0

Block Parameters

Channel vector

Enter numbers between 1 and 8 to select the digital input lines used with this port. This driver allows the selection of individual digital input lines in arbitrary order. The number of elements defines the number of digital lines used.

For example, to use all of the digital inputs for one port, enter

```
[1,2,3,4,5,6,7,8]
```

Number the lines beginning with 1 even if this board manufacturer starts numbering the lines with 0.

Sample time

Enter the base sample time or a multiple of the base sample time (-1 means sample time is inherited).

PCI slot (-1:autosearch)

If only one board of this type is in the target computer, enter -1 to locate the board.

If two or more boards of this type are in the target computer, enter the bus number and the PCI slot number of the board associated with this driver block. Use the format **[BusNumber,SlotNumber]**.

To determine the bus number and the PCI slot number, type:

```
tg = slrt;  
getPCIInfo(tg, 'installed')
```

External Websites

- www.ni.com

National Instruments PCI-6023E Digital Output

PCI-6023E Digital Output

Library

Simulink Real-Time Library for National Instruments

Scaling Input to Output

I/O Module Output	Block Input Data Type	Scaling
TTL	Double	< 0.5 = TTL low ≥ 0.5 = TTL high

Block Parameters

Channel vector

Enter numbers between 1 and 8 to select the digital output lines used with this port. This driver allows the selection of individual digital output lines in arbitrary order. The number of elements defines the number of digital lines used.

For example, to use all of the digital outputs for one port, enter

```
[1,2,3,4,5,6,7,8]
```

Number the lines beginning with 1 even if this board manufacturer starts numbering the lines with 0.

Reset vector

The reset vector controls the behavior of the channel at model termination. Enter a scalar or a vector that is the same length as the channel vector. If you specify a scalar value, that setting is replicated over the channel vector. If you specify a value of 1, the corresponding channel is reset to the value specified in the initial value vector. If you specify a value of 0, the channel remains at the last value attained while the model was running.

Initial value vector

The initial value vector contains the initial values (0 or 1) of the output channels. Enter a scalar or a vector that is the same length as the channel vector. If you enter a scalar, that value is replicated as the initial value over the channel vector. The channels are set to these initial values between the time the model is downloaded and the time it is started.

Sample time

Enter the base sample time or a multiple of the base sample time (- 1 means sample time is inherited).

PCI slot (-1:autosearch)

If only one board of this type is in the target computer, enter - 1 to locate the board.

If two or more boards of this type are in the target computer, enter the bus number and the PCI slot number of the board associated with this driver block. Use the format **[BusNumber,SlotNumber]**.

To determine the bus number and the PCI slot number, type:

```
tg = slrt;  
getPCIInfo(tg, 'installed')
```

External Websites

- www.ni.com

National Instruments PCI-6023E Pulse Generation

PCI-6023E Pulse Generation

Library

Simulink Real-Time Library for National Instruments

Note

The inputs to the block should be a two-element vector. The first element is the number of counts (of the 20 MHz source clock) that the counter should maintain at a low level, and the second element is the number of clock ticks for a high level. For example, to generate a pulse train at 1 kHz with 25% low and 75% high, use the vector

```
[5000 15000]
```

Block Parameters

Counter

From the list, choose **Counter 0**, **Counter 1**, or **Both** to select the counter(s) to be used with this driver block. In each case, one block is required for each physical board.

Sample time

Enter the base sample time or a multiple of the base sample time (-1 means sample time is inherited).

PCI slot (-1:autosearch)

If only one board of this type is in the target computer, enter -1 to locate the board.

If two or more boards of this type are in the target computer, enter the bus number and the PCI slot number of the board associated with this driver block. Use the format **[BusNumber, SlotNumber]**.

To determine the bus number and the PCI slot number, type:

```
tg = slrt;  
getPCIInfo(tg, 'installed')
```

External Websites

- www.ni.com

National Instruments PCI-6023E Pulse Width/Period Measurement

PCI-6023E Pulse Width/Period Measurement

Library

Simulink Real-Time Library for National Instruments

Note

Connect the signal you want to measure to the GATE input of the chosen counter. The signal must have fast rise and fall times; otherwise, the counter might experience false triggering. Use signal voltage levels between 0 and 5 volts (TTL levels).

Block Parameters

Counter

From the list, select a counter, 0 or 1.

Trigger mode

From the list, choose **Level Triggered** or **Edge Triggered**. See the table below for an example of how **Trigger mode** and **Polarity** interact. In this table, the data in the Output column is the result of a 1 kHz pulse train with a 25% low and a 75% high pulse.

Polarity

From the list, choose **Active low** or **Active high**. See the table below for an example of how **Trigger mode** and **Polarity** interact. In this table, the data in the Output column resulted from a 1 kHz pulse train with a 25% low and a 75% high pulse.

Measurement Objective	Trigger Mode	Polarity	Output
Pulse width (low pulse)	Level triggered	Active low	5000

Measurement Objective	Trigger Mode	Polarity	Output
Pulse width (high pulse)	Level triggered	Active high	15000
Period	Edge triggered	NA	20000

In every case, the output of the block is the number of clock ticks (of the 20 MHz source clock) required for the specified measurement. When measuring pulse width, the output reflects the number of clock ticks for which the input signal was in the specified (low or high) state. See the table above for an example.

Sample time

Enter the base sample time or a multiple of the base sample time (- 1 means sample time is inherited).

PCI slot (-1:autosearch)

If only one board of this type is in the target computer, enter - 1 to locate the board.

If two or more boards of this type are in the target computer, enter the bus number and the PCI slot number of the board associated with this driver block. Use the format [**BusNumber,SlotNumber**].

To determine the bus number and the PCI slot number, type:

```
tg = slrt;
getPCIInfo(tg, 'installed')
```

External Websites

- www.ni.com

National Instruments PCI-6024E

Support for National Instruments PCI-6024E board

Board

National Instruments PCI-6024E

General Description

The PCI-6024E is an I/O board with 16 single or 8 differential analog input (A/D) channels (12-bit) with a maximum sample rate of 200 kHz, 2 analog output (D/A) channels (12-bit), 8 digital input and output lines, and 2 counter/timers (24-bit) with a maximum source clock rate of 20 MHz.

The Simulink Real-Time block library supports this board with these driver blocks:

- National Instruments PCI-6024E Analog Input (A/D)
- National Instruments PCI-6024E Analog Output (D/A)
- National Instruments PCI-6024E Digital Input
- National Instruments PCI-6024E Digital Output
- National Instruments PCI-6024E Pulse Generation
- National Instruments PCI-6024E Pulse Width/Period Measurement

Board Characteristics

Board name	PCI-6024E
Manufacturer	National Instruments
Bus type	PCI
Access method	Memory mapped
Multiple block instance support	A/D: No, D/A: No, Digital I/O: Yes; Pulse Width/Period measurement: Yes; Pulse Train Generation: No

Multiple board support

Yes

External Websites

- www.ni.com

National Instruments PCI-6024E Analog Input (A/D)

PCI-6024E Analog Input block

Library

Simulink Real-Time Library for National Instruments

Scaling Input to Output

I/O Module Input	Block Output Data Type	Scaling
Volts	Double	1

Block Parameters

Channel vector

Enter numbers between 1 and 16. This driver allows you to enter channel numbers in arbitrary order.

For example, to use the first, second, and fifth channels, enter

[1,2,5]

Number the channels beginning with 1 even if this board manufacturer starts numbering the channels with 0.

Range vector

Enter a range code for each of the channels in the channel vector. The range vector must be the same length as the channel vector. This driver allows each channel to be different.

The following table is a list of the ranges for this driver and the corresponding range codes.

Input Range (V)	Range Code
-10 to +10	-10

Input Range (V)	Range Code
-5 to +5	-5
-0.5 to +0.5	-0.5
-0.05 to +0.05	-0.05

For example, if the first channel is -10 to +10 volts and the second and fifth channels are -5 to +5 volts, enter

[-10, -5, -5]

Input coupling vector

Enter a coupling code for each of the channels in the channel vector. The coupling vector must be the same length as the channel vector. This driver allows a different coupling for each channel.

The following table is a list of the couplings for this driver and the corresponding coupling codes.

Coupling	Coupling Code	Description
RSE	0	Analog input line connected to the positive input of the PGIA. Analog input ground (AIGND) internally connected to the negative input of the PGIA. See the board manual.
NRSE	1	Analog input line connected to the positive input of the PGIA. Analog input sense (AISENSE) connected to the negative input of the PGIA. See the board manual.
DIFF	2	First analog input line connected to the positive input of the PGIA. Second analog input line connected to the negative input of the PGIA. See the board manual.

For example, if the first and second channels are single input and the fifth channel is a differential input, enter

[0,0,2]

The driver selects a second differential input 8 channels higher than the first channel. In the example above, the driver would select the thirteenth channel as a differential input with the fifth channel.

If the board is set up for differential mode, you can read the data from either of the channels in the differential pair. For example, if you have a differential pair of 1 and 9, you can read the data from channel 1 or channel 9. However, you might want to read the lower channel number of the pair because it remains unchanged when you switch the input mode between single-ended and differential.

Sample time

Enter the base sample time or a multiple of the base sample time (- 1 means sample time is inherited).

PCI slot (-1:autosearch)

If only one board of this type is in the target computer, enter - 1 to locate the board.

If two or more boards of this type are in the target computer, enter the bus number and the PCI slot number of the board associated with this driver block. Use the format [**BusNumber**,**SlotNumber**].

To determine the bus number and the PCI slot number, type:

```
tg = slrt;  
getPCIInfo(tg, 'installed')
```

External Websites

- www.ni.com

National Instruments PCI-6024E Analog Output (D/A)

PCI-6024E Analog Output block

Library

Simulink Real-Time Library for National Instruments

Note

The analog output range of this board is set -10 to +10 volts.

Scaling Input to Output

I/O Module Output	Block Input Data Type	Scaling
Volts	Double	1

Block Parameters

Channel vector

Enter 1 or 2. This driver allows the selection of individual D/A channels in arbitrary order. The number of elements defines the number of D/A channels used. For example, to use both of the analog output channels, enter

[1,2]

Number the channels beginning with 1 even if this board manufacturer starts numbering the channels with 0.

Reset vector

The reset vector controls the behavior of the channel at model termination. Enter a scalar or a vector that is the same length as the channel vector. If you specify a scalar

value, that setting is replicated over the channel vector. If you specify a value of 1, the corresponding channel is reset to the value specified in the initial value vector. If you specify a value of 0, the channel remains at the last value attained while the model was running.

Initial value vector

The initial value vector contains the initial voltage values for the output channels. Enter a scalar or a vector that is the same length as the channel vector. If you specify a scalar value, that value is replicated as the initial value over the channel vector. The channels are set to the initial values between the time the model is downloaded and the time it is started.

Sample time

Enter the base sample time or a multiple of the base sample time (- 1 means sample time is inherited).

PCI slot (-1:autosearch)

If only one board of this type is in the target computer, enter - 1 to locate the board.

If two or more boards of this type are in the target computer, enter the bus number and the PCI slot number of the board associated with this driver block. Use the format **[BusNumber, SlotNumber]**.

To determine the bus number and the PCI slot number, type:

```
tg = slrt;  
getPCIInfo(tg, 'installed')
```

External Websites

- www.ni.com

National Instruments PCI-6024E Digital Input

PCI-6024E Digital Input block

Library

Simulink Real-Time Library for National Instruments

Scaling Input to Output

I/O Module Input	Block Output Data Type	Scaling
TTL	Double	TTL low = 0.0 TTL high = 1.0

Block Parameters

Channel vector

Enter numbers between 1 and 8 to select the digital input lines used with this port. This driver allows the selection of individual digital input lines in arbitrary order. The number of elements defines the number of digital lines used.

For example, to use all of the digital inputs for one port, enter

```
[1,2,3,4,5,6,7,8]
```

Number the lines beginning with 1 even if this board manufacturer starts numbering the lines with 0.

Sample time

Enter the base sample time or a multiple of the base sample time (-1 means sample time is inherited).

PCI slot (-1:autosearch)

If only one board of this type is in the target computer, enter -1 to locate the board.

If two or more boards of this type are in the target computer, enter the bus number and the PCI slot number of the board associated with this driver block. Use the format **[BusNumber,SlotNumber]**.

To determine the bus number and the PCI slot number, type:

```
tg = slrt;  
getPCIInfo(tg, 'installed')
```

External Websites

- www.ni.com

National Instruments PCI-6024E Digital Output

PCI-6024E Digital Output

Library

Simulink Real-Time Library for National Instruments

Scaling Input to Output

I/O Module Output	Block Input Data Type	Scaling
TTL	Double	$< 0.5 = \text{TTL low}$ $\geq 0.5 = \text{TTL high}$

Block Parameters

Channel vector

Enter numbers between 1 and 8 to select the digital output lines used with this port. This driver allows the selection of individual digital output lines in arbitrary order. The number of elements defines the number of digital lines used.

For example, to use all of the digital outputs for one port, enter

[1,2,3,4,5,6,7,8]

Number the lines beginning with 1 even if this board manufacturer starts numbering the lines with 0.

Reset vector

The reset vector controls the behavior of the channel at model termination. Enter a scalar or a vector that is the same length as the channel vector. If you specify a scalar value, that setting is replicated over the channel vector. If you specify a value of 1, the corresponding channel is reset to the value specified in the initial value vector. If you specify a value of 0, the channel remains at the last value attained while the model was running.

Initial value vector

The initial value vector contains the initial values (0 or 1) of the output channels. Enter a scalar or a vector that is the same length as the channel vector. If you enter a scalar, that value is replicated as the initial value over the channel vector. The channels are set to these initial values between the time the model is downloaded and the time it is started.

Sample time

Enter the base sample time or a multiple of the base sample time (-1 means sample time is inherited).

PCI slot (-1:autosearch)

If only one board of this type is in the target computer, enter -1 to locate the board.

If two or more boards of this type are in the target computer, enter the bus number and the PCI slot number of the board associated with this driver block. Use the format **[BusNumber,SlotNumber]**.

To determine the bus number and the PCI slot number, type:

```
tg = slrt;  
getPCIInfo(tg, 'installed')
```

External Websites

- www.ni.com

National Instruments PCI-6024E Pulse Generation

PCI-6024E Pulse Generation

Library

Simulink Real-Time Library for National Instruments

Note

The inputs to the block should be a two-element vector. The first element is the number of counts (of the 20 MHz source clock) that the counter should maintain at a low level, and the second element is the number of clock ticks for a high level. For example, to generate a pulse train at 1 kHz with 25% low and 75% high, use the vector

```
[5000 15000]
```

Block Parameters

Counter

From the list, choose **Counter 0**, **Counter 1**, or **Both** to select the counter(s) to be used with this driver block. In each case, one block is required for each physical board.

Sample time

Enter the base sample time or a multiple of the base sample time (-1 means sample time is inherited).

PCI slot (-1:autosearch)

If only one board of this type is in the target computer, enter -1 to locate the board.

If two or more boards of this type are in the target computer, enter the bus number and the PCI slot number of the board associated with this driver block. Use the format **[BusNumber, SlotNumber]**.

To determine the bus number and the PCI slot number, type:

```
tg = slrt;  
getPCIInfo(tg, 'installed')
```

External Websites

- www.ni.com

National Instruments PCI-6024E Pulse Width/Period Measurement

PCI-6024E Pulse Width/Period Measurement

Library

Simulink Real-Time Library for National Instruments

Note

Connect the signal you want to measure to the GATE input of the chosen counter. The signal must have fast rise and fall times; otherwise, the counter might experience false triggering. Use signal voltage levels between 0 and 5 volts (TTL levels).

Block Parameters

Counter

From the list, select a counter, 0 or 1.

Trigger mode

From the list, choose **Level Triggered** or **Edge Triggered**. See the table below for an example of how **Trigger mode** and **Polarity** interact. In this table, the data in the Output column resulted from a 1 kHz pulse train with a 25% low and a 75% high pulse.

Polarity

From the list, choose **Active low** or **Active high**. See the table below for an example of how **Trigger mode** and **Polarity** interact. In this table, the data in the Output column resulted from a 1 kHz pulse train with a 25% low and a 75% high pulse.

Measurement Objective	Trigger Mode	Polarity	Output
Pulse width (low pulse)	Level triggered	Active low	5000

Measurement Objective	Trigger Mode	Polarity	Output
Pulse width (high pulse)	Level triggered	Active high	15000
Period	Edge triggered	NA	20000

In every case, the output of the block is the number of clock ticks (of the 20 MHz source clock) required for the specified measurement. When measuring pulse width, the output reflects the number of clock ticks for which the input signal was in the specified (low or high) state. See the table above for an example.

Sample time

Enter the base sample time or a multiple of the base sample time (- 1 means sample time is inherited).

PCI slot (-1:autosearch)

If only one board of this type is in the target computer, enter - 1 to locate the board.

If two or more boards of this type are in the target computer, enter the bus number and the PCI slot number of the board associated with this driver block. Use the format **[BusNumber,SlotNumber]**.

To determine the bus number and the PCI slot number, type:

```
tg = slrt;
getPCIInfo(tg, 'installed')
```

External Websites

- www.ni.com

National Instruments PCI-6025E

Support for National Instruments PCI-6025E board

Board

National Instruments PCI-6025E

General Description

The PCI-6025E is an I/O board with 16 single or 8 differential analog inputs (A/D) channels (12-bit) with a maximum sample rate of 200 kHz, 2 analog output channels (12-bit), 32 digital input and output lines, and 2 counter/timers (24-bit) with a maximum source clock rate of 20 MHz.

The PCI-6025E provides 8 digital input and output lines, the PCI-6025E 8255 provides an additional 24 digital input and output lines.

The Simulink Real-Time block library supports this board with these driver blocks:

- National Instruments PCI-6025E Analog Input (A/D)
- National Instruments PCI-6025E Analog Output (D/A)
- National Instruments PCI-6025E and PCI-6025E 8255 Digital Input
- National Instruments PCI-6025E Digital Output
- National Instruments PCI-6025E Pulse Generation
- National Instruments PCI-6025E Pulse Width/Period Measurement

Board Characteristics

Board name	PCI-6025E
Manufacturer	National Instruments
Bus type	PCI
Access method	Memory mapped

Multiple block instance support

A/D: No, D/A: No, Digital I/O: Yes; Pulse
Width/Period measurement: Yes; Pulse
Train Generation: No

Multiple board support

Yes

External Websites

- www.ni.com

National Instruments PCI-6025E Analog Input (A/D)

PCI-6025E Analog Input block

Library

Simulink Real-Time Library for National Instruments

Scaling Input to Output

I/O Module Input	Block Output Data Type	Scaling
Volts	Double	1

Block Parameters

Channel vector

Enter numbers between 1 and 16. This driver allows you to enter channel numbers in arbitrary order.

For example, to use the first, second, and fifth channels, enter

```
[1,2,5]
```

Number the channels beginning with 1 even if this board manufacturer starts numbering the channels with 0.

Range vector

Enter a range code for each of the channels in the channel vector. The range vector must be the same length as the channel vector. This driver allows each channel to be different.

The following table is a list of the ranges for this driver and the corresponding range codes.

Input Range (V)	Range Code
-10 to +10	-10

Input Range (V)	Range Code
-5 to +5	-5
-0.5 to +0.5	-0.5
-0.05 to +0.05	-0.05

For example, if the first channel is -10 to +10 volts and the second and fifth channels are -5 to +5 volts, enter

[-10, -5, -5]

Input coupling vector

Enter a coupling code for each of the channels in the channel vector. The coupling vector must be the same length as the channel vector. This driver allows a different coupling for each channel.

The following table is a list of the couplings for this driver and the corresponding coupling codes.

Coupling	Coupling Code	Description
RSE	0	Analog input line connected to the positive input of the PGIA. Analog input ground (AIGND) internally connected to the negative input of the PGIA. See the board manual.
NRSE	1	Analog input line connected to the positive input of the PGIA. Analog input sense (AISENSE) connected to the negative input of the PGIA. See the board manual.
DIFF	2	First analog input line connected to the positive input of the PGIA. Second analog input line connected to the negative input of the PGIA. See the board manual.

For example, if the first and second channels are single input and the fifth channel is a differential input, enter

[0, 0, 2]

The driver selects a second differential input 8 channels higher than the first channel. In the example above, the driver would select the thirteenth channel as a differential input with the fifth channel.

If the board is set up for differential mode, you can read the data from either of the channels in the differential pair. For example, if you have a differential pair of 1 and 9, you can read the data from channel 1 or channel 9. However, you might want to read the lower channel number of the pair because it remains unchanged when you switch the input mode between single-ended and differential.

Sample time

Enter the base sample time or a multiple of the base sample time (- 1 means sample time is inherited).

PCI slot (-1:autosearch)

If only one board of this type is in the target computer, enter - 1 to locate the board.

If two or more boards of this type are in the target computer, enter the bus number and the PCI slot number of the board associated with this driver block. Use the format [**BusNumber**,**SlotNumber**].

To determine the bus number and the PCI slot number, type:

```
tg = slrt;  
getPCIInfo(tg, 'installed')
```

External Websites

- www.ni.com

National Instruments PCI-6025E Analog Output (D/A)

PCI-6025E Analog Output block

Library

Simulink Real-Time Library for National Instruments

Note

The analog output range of this board is set -10 to +10 volts.

Scaling Input to Output

I/O Module Output	Block Input Data Type	Scaling
Volts	Double	1

Block Parameters

Channel vector

Enter 1 or 2. This driver allows the selection of individual D/A channels in arbitrary order. The number of elements defines the number of D/A channels used. For example, to use both of the analog output channels, enter

[1,2]

Number the channels beginning with 1 even if this board manufacturer starts numbering the channels with 0.

Reset vector

The reset vector controls the behavior of the channel at model termination. Enter a scalar or a vector that is the same length as the channel vector. If you specify a scalar

value, that setting is replicated over the channel vector. If you specify a value of 1, the corresponding channel is reset to the value specified in the initial value vector. If you specify a value of 0, the channel remains at the last value attained while the model was running.

Initial value vector

The initial value vector contains the initial voltage values for the output channels. Enter a scalar or a vector that is the same length as the channel vector. If you specify a scalar value, that value is replicated as the initial value over the channel vector. The channels are set to the initial values between the time the model is downloaded and the time it is started.

Sample time

Enter the base sample time or a multiple of the base sample time (- 1 means sample time is inherited).

PCI slot (-1:autosearch)

If only one board of this type is in the target computer, enter - 1 to locate the board.

If two or more boards of this type are in the target computer, enter the bus number and the PCI slot number of the board associated with this driver block. Use the format **[BusNumber, SlotNumber]**.

To determine the bus number and the PCI slot number, type:

```
tg = slrt;  
getPCIInfo(tg, 'installed')
```

External Websites

- www.ni.com

National Instruments PCI-6025E and PCI-6025E 8255 Digital Input

PCI-6025E and PCI-6025E 8255 Digital Input blocks

Library

Simulink Real-Time Library for National Instruments

Scaling Input to Output

I/O Module Input	Block Output Data Type	Scaling
TTL	Double	TTL low = 0.0 TTL high = 1.0

Block Parameters

Channel vector

Enter numbers between 1 and 8 to select the digital input lines used with this port. This driver allows the selection of individual digital input lines in arbitrary order. The number of elements defines the number of digital lines used.

For example, to use all of the digital inputs for one port, enter

```
[1,2,3,4,5,6,7,8]
```

Number the lines beginning with 1 even if this board manufacturer starts numbering the lines with 0.

Port

(PCI-6025E 8255) From the list, choose either A, B, or C. The I/O board has an 82C55A chip with 3 ports. The port name defines which port of the 82C55A chip is used for this driver block. Each port has a maximum of 8 digital lines that can be configured as inputs. The PCI-6025E provides 8 digital input lines, the PCI-6025E

8255 provides an additional 24 digital input lines, distributed across the ports A, B, and C. In each case, one block is required for each port.

Sample time

Enter the base sample time or a multiple of the base sample time (- 1 means sample time is inherited).

PCI slot (-1:autosearch)

If only one board of this type is in the target computer, enter - 1 to locate the board.

If two or more boards of this type are in the target computer, enter the bus number and the PCI slot number of the board associated with this driver block. Use the format **[BusNumber,SlotNumber]**.

To determine the bus number and the PCI slot number, type:

```
tg = slrt;  
getPCIInfo(tg, 'installed')
```

External Websites

- www.ni.com

National Instruments PCI-6025E Digital Output

PCI-6025E Digital Output block

Library

Simulink Real-Time Library for National Instruments

Scaling Input to Output

I/O Module Output	Block Input Data Type	Scaling
TTL	Double	$< 0.5 = \text{TTL low}$ $\geq 0.5 = \text{TTL high}$

Block Parameters

Channel vector

Enter numbers between 1 and 8 to select the digital output lines used with this port. This driver allows the selection of individual digital output lines in arbitrary order. The number of elements defines the number of digital lines used.

For example, to use all of the digital outputs for one port, enter

```
[1,2,3,4,5,6,7,8]
```

Number the lines beginning with 1 even if this board manufacturer starts numbering the lines with 0.

Port

(PCI-6025E 8255) From the list, choose either A, B, or C. The I/O board has an 82C55A chip with 3 ports. The port name defines which port of the 82C55A chip is used for this driver block. Each port has a maximum of 8 digital lines that can be configured as inputs. The PCI-6025E provides 8 digital input lines, the PCI-6025E 8255 provides an additional 24 digital input lines, distributed across the ports A, B, and C. In each case, one block is required for each port.

Reset vector

The reset vector controls the behavior of the channel at model termination. Enter a scalar or a vector that is the same length as the channel vector. If you specify a scalar value, that setting is replicated over the channel vector. If you specify a value of 1, the corresponding channel is reset to the value specified in the initial value vector. If you specify a value of 0, the channel remains at the last value attained while the model was running.

Initial value vector

The initial value vector contains the initial values (0 or 1) of the output channels. Enter a scalar or a vector that is the same length as the channel vector. If you enter a scalar, that value is replicated as the initial value over the channel vector. The channels are set to these initial values between the time the model is downloaded and the time it is started.

Sample time

Enter the base sample time or a multiple of the base sample time (- 1 means sample time is inherited).

PCI slot (-1:autosearch)

If only one board of this type is in the target computer, enter - 1 to locate the board.

If two or more boards of this type are in the target computer, enter the bus number and the PCI slot number of the board associated with this driver block. Use the format **[BusNumber, SlotNumber]**.

To determine the bus number and the PCI slot number, type:

```
tg = slrt;  
getPCIInfo(tg, 'installed')
```

External Websites

- www.ni.com

National Instruments PCI-6025E Pulse Generation

PCI-6025E Pulse Generation block

Library

Simulink Real-Time Library for National Instruments

Note

The inputs to the block should be a two-element vector. The first element is the number of counts (of the 20 MHz source clock) that the counter should maintain at a low level, and the second element is the number of clock ticks for a high level. For example, to generate a pulse train at 1 kHz with 25% low and 75% high, use the vector

```
[5000 15000]
```

Block Parameters

Counter

From the list, choose **Counter 0**, **Counter 1**, or **Both** to select the counter(s) to be used with this driver block. In each case, one block is required for each physical board.

Sample time

Enter the base sample time or a multiple of the base sample time (-1 means sample time is inherited).

PCI slot (-1:autosearch)

If only one board of this type is in the target computer, enter -1 to locate the board.

If two or more boards of this type are in the target computer, enter the bus number and the PCI slot number of the board associated with this driver block. Use the format **[BusNumber, SlotNumber]**.

To determine the bus number and the PCI slot number, type:

```
tg = slrt;  
getPCIInfo(tg, 'installed')
```

External Websites

- www.ni.com

National Instruments PCI-6025E Pulse Width/Period Measurement

PCI-6025E Pulse Width/Period Measurement block

Library

Simulink Real-Time Library for National Instruments

Note

Connect the signal you want to measure to the GATE input of the chosen counter. The signal must have fast rise and fall times; otherwise, the counter might experience false triggering. Use signal voltage levels between 0 and 5 volts (TTL levels).

Block Parameters

Counter

From the list, select a counter, 0 or 1.

Trigger mode

From the list, choose **Level Triggered** or **Edge Triggered**. See the table below for an example of how **Trigger mode** and **Polarity** interact. In this table, the data in the Output column resulted from a 1 kHz pulse train with a 25% low and a 75% high pulse.

Polarity

From the list, choose **Active low** or **Active high**. See the table below for an example of how **Trigger mode** and **Polarity** interact. In this table, the data in the Output column resulted from a 1 kHz pulse train with a 25% low and a 75% high pulse.

Measurement Objective	Trigger Mode	Polarity	Output
Pulse width (low pulse)	Level triggered	Active low	5000

Measurement Objective	Trigger Mode	Polarity	Output
Pulse width (high pulse)	Level triggered	Active high	15000
Period	Edge triggered	NA	20000

In every case, the output of the block is the number of clock ticks (of the 20 MHz source clock) required for the specified measurement. When measuring pulse width, the output reflects the number of clock ticks for which the input signal was in the specified (low or high) state. See the table above for an example.

Sample time

Enter the base sample time or a multiple of the base sample time (- 1 means sample time is inherited).

PCI slot (-1:autosearch)

If only one board of this type is in the target computer, enter - 1 to locate the board.

If two or more boards of this type are in the target computer, enter the bus number and the PCI slot number of the board associated with this driver block. Use the format **[BusNumber,SlotNumber]**.

To determine the bus number and the PCI slot number, type:

```
tg = slrt;
getPCIInfo(tg, 'installed')
```

External Websites

- www.ni.com

National Instruments PCI-6040E (formerly PCI-MIO-16E-4)

Support for National Instruments PCI-6040E board

Board

National Instruments PCI-6040E

General Description

This was formerly PCI-MIO-16E-4.

The PCI-6040E is an I/O board with 16 single or 8 differential analog input channels (12-bit) with a maximum sample rate of 500 kHz, 2 analog output channels (12-bit), 8 digital input and output lines, and 2 counter/timers (24-bit) with a maximum source clock rate of 20 MHz.

The Simulink Real-Time block library supports this board with these driver blocks:

- National Instruments PCI-6040E Analog Input (A/D) (formerly PCI-MIO-16E-4)
- National Instruments PCI-6040E Analog Output (D/A) (formerly PCI-MIO-16E-4)
- National Instruments PCI-6040E Digital Input (formerly PCI-MIO-16E-4)
- National Instruments PCI-6040E Digital Output (formerly PCI-MIO-16E-4)
- National Instruments PCI-6040E Pulse Generation (formerly PCI-MIO-16E-4)
- National Instruments PCI-6040E Pulse Width/Period Measurement (formerly PCI-MIO-16E-4)

Board Characteristics

Board name	PCI-6040E
Manufacturer	National Instruments
Bus type	PCI

Access method

Memory mapped

Multiple block instance support

A/D: No, D/A: No, Digital I/O: Yes; Pulse
Width/Period measurement: Yes; Pulse
Train Generation: No

Multiple board support

Yes

External Websites

- www.ni.com

National Instruments PCI-6040E Analog Input (A/D) (formerly PCI-MIO-16E-4)

PCI-6040E Analog Input block

Library

Simulink Real-Time Library for National Instruments

Scaling Input to Output

I/O Module Input	Block Output Data Type	Scaling
Volts	Double	1

Block Parameters

Channel vector

Enter numbers between 1 and 16. This driver allows you to enter channel numbers in arbitrary order.

For example, to use the first, second, and fifth channels, enter

```
[1,2,5]
```

Number the channels beginning with 1 even if this board manufacturer starts numbering the channels with 0.

Range vector

Enter a range code for each of the channels in the channel vector. The range vector must be the same length as the channel vector. This driver allows each channel to be different.

The following table is a list of the ranges for this driver and the corresponding range codes.

Input Range (V)	Range Code
-10 to +10	-10
-5 to +5	-5
-2 to +2	-2
-1 to +1	-1
-0.5 to +0.5	-0.5
-0.2 to +0.2	-0.2
-0.1 to +0.1	-0.1
-0.05 to +0.05	-0.05
0 to +10	10
0 to +5	5
0 to +2	2
0 to +1	1
0 to +0.5	0.5
0 to +0.2	0.2
0 to +0.1	0.1

For example, if the first channel is -10 to +10 volts and the second and fifth channels are 0 to +1 volts, enter

[-10, 1, 1]

Input coupling vector

Enter a coupling code for each of the channels in the channel vector. The coupling vector must be the same length as the channel vector. This driver allows a different coupling for each channel.

The following table is a list of the couplings for this driver and the corresponding coupling codes.

Coupling	Coupling Code	Description
RSE	0	Analog input line connected to the positive input of the PGIA. Analog input ground (AIGND) internally connected to the negative input of the PGIA. See the board manual.

Coupling	Coupling Code	Description
NRSE	1	Analog input line connected to the positive input of the PGIA. Analog input sense (AISENSE) connected to the negative input of the PGIA. See the board manual.
DIFF	2	First analog input line connected to the positive input of the PGIA. Second analog input line connected to the negative input of the PGIA. See the board manual.

For example, if the first and second channels are single input and the fifth channel is a differential input, enter

```
[0,0,2]
```

The driver selects a second differential input 8 channels higher than the first channel. In the example above, the driver would select the thirteenth channel as a differential input with the fifth channel.

If the board is set up for differential mode, you can read the data from either of the channels in the differential pair. For example, if you have a differential pair of 1 and 9, you can read the data from channel 1 or channel 9. However, you might want to read the lower channel number of the pair because it remains unchanged when you switch the input mode between single-ended and differential.

Sample time

Enter the base sample time or a multiple of the base sample time (- 1 means sample time is inherited).

PCI slot (-1:autosearch)

If only one board of this type is in the target computer, enter - 1 to locate the board.

If two or more boards of this type are in the target computer, enter the bus number and the PCI slot number of the board associated with this driver block. Use the format **[BusNumber,SlotNumber]**.

To determine the bus number and the PCI slot number, type:

```
tg = slrt;
getPCIInfo(tg, 'installed')
```

External Websites

- www.ni.com

National Instruments PCI-6040E Analog Output (D/A) (formerly PCI-MIO-16E-4)

PCI-6040E Analog Output block

Library

Simulink Real-Time Library for National Instruments

Scaling Input to Output

I/O Module Output	Block Input Data Type	Scaling
Volts	Double	1

Block Parameters

Channel vector

Enter 1 or 2. This driver allows the selection of individual D/A channels in arbitrary order. The number of elements defines the number of D/A channels used. For example, to use both of the analog output channels, enter

[1,2]

Number the channels beginning with 1 even if this board manufacturer starts numbering the channels with 0.

Range vector

Enter a range code for each of the channels in the channel vector. The range vector must be the same length as the channel vector. This board allows the range of each channel to be different.

The following table is a list of the ranges for this driver and the corresponding range codes.

Input Range (V)	Range Code
-10 to +10	-10

Input Range (V)	Range Code
0 to +10	10

For example, if the first channel is -10 to +10 volts and the second channel is 0 to +10 volts, enter

```
[-10, 10]
```

Reset vector

The reset vector controls the behavior of the channel at model termination. Enter a scalar or a vector that is the same length as the channel vector. If you specify a scalar value, that setting is replicated over the channel vector. If you specify a value of 1, the corresponding channel is reset to the value specified in the initial value vector. If you specify a value of 0, the channel remains at the last value attained while the model was running.

Initial value vector

The initial value vector contains the initial voltage values for the output channels. Enter a scalar or a vector that is the same length as the channel vector. If you specify a scalar value, that value is replicated as the initial value over the channel vector. The channels are set to the initial values between the time the model is downloaded and the time it is started.

Sample time

Enter the base sample time or a multiple of the base sample time (-1 means sample time is inherited).

PCI slot (-1:autosearch)

If only one board of this type is in the target computer, enter -1 to locate the board.

If two or more boards of this type are in the target computer, enter the bus number and the PCI slot number of the board associated with this driver block. Use the format **[BusNumber, SlotNumber]**.

To determine the bus number and the PCI slot number, type:

```
tg = slrt;
getPCIInfo(tg, 'installed')
```

External Websites

- www.ni.com

National Instruments PCI-6040E Digital Input (formerly PCI-MIO-16E-4)

PCI-6040E Digital Input block

Library

Simulink Real-Time Library for National Instruments

Scaling Input to Output

I/O Module Input	Block Output Data Type	Scaling
TTL	Double	TTL low = 0.0 TTL high = 1.0

Block Parameters

Channel vector

Enter numbers between 1 and 8 to select the digital input lines used with this port. This driver allows the selection of individual digital input lines in arbitrary order. The number of elements defines the number of digital lines used.

For example, to use all of the digital inputs for one port, enter

```
[1,2,3,4,5,6,7,8]
```

Number the lines beginning with 1 even if this board manufacturer starts numbering the lines with 0.

Sample time

Enter the base sample time or a multiple of the base sample time (-1 means sample time is inherited).

PCI slot (-1:autosearch)

If only one board of this type is in the target computer, enter -1 to locate the board.

If two or more boards of this type are in the target computer, enter the bus number and the PCI slot number of the board associated with this driver block. Use the format **[BusNumber,SlotNumber]**.

To determine the bus number and the PCI slot number, type:

```
tg = slrt;  
getPCIInfo(tg, 'installed')
```

External Websites

- www.ni.com

National Instruments PCI-6040E Digital Output (formerly PCI-MIO-16E-4)

PCI-6040E Digital Output block

Library

Simulink Real-Time Library for National Instruments

Scaling of Input to Output

I/O Module Output	Block Input Data Type	Scaling
TTL	Double	$< 0.5 = \text{TTL low}$ $\geq 0.5 = \text{TTL high}$

Block Parameters

Channel vector

Enter numbers between 1 and 8 to select the digital output lines used with this port. This driver allows the selection of individual digital output lines in arbitrary order. The number of elements defines the number of digital lines used.

For example, to use all of the digital outputs for one port, enter

```
[ 1, 2, 3, 4, 5, 6, 7, 8 ]
```

Number the lines beginning with 1 even if this board manufacturer starts numbering the lines with 0.

Reset vector

The reset vector controls the behavior of the channel at model termination. Enter a scalar or a vector that is the same length as the channel vector. If you specify a scalar value, that setting is replicated over the channel vector. If you specify a value of 1, the corresponding channel is reset to the value specified in the initial value vector.

If you specify a value of 0, the channel remains at the last value attained while the model was running.

Initial value vector

The initial value vector contains the initial values (0 or 1) of the output channels. Enter a scalar or a vector that is the same length as the channel vector. If you enter a scalar, that value is replicated as the initial value over the channel vector. The channels are set to these initial values between the time the model is downloaded and the time it is started.

Sample time

Enter the base sample time or a multiple of the base sample time (- 1 means sample time is inherited).

PCI slot (-1:autosearch)

If only one board of this type is in the target computer, enter - 1 to locate the board.

If two or more boards of this type are in the target computer, enter the bus number and the PCI slot number of the board associated with this driver block. Use the format **[BusNumber, SlotNumber]**.

To determine the bus number and the PCI slot number, type:

```
tg = slrt;  
getPCIInfo(tg, 'installed')
```

External Websites

- www.ni.com

National Instruments PCI-6040E Pulse Generation (formerly PCI-MIO-16E-4)

PCI-6040E Pulse Generation block

Library

Simulink Real-Time Library for National Instruments

Note

The inputs to the block should be a two-element vector. The first element is the number of counts (of the 20 MHz source clock) that the counter should maintain at a low level, and the second element is the number of clock ticks for a high level. For example, to generate a pulse train at 1 kHz with 25% low and 75% high, use the vector

```
[5000 15000]
```

Block Parameters

Counter

From the list, choose **Counter 0**, **Counter 1**, or **Both** to select the counter(s) to be used with this driver block. In each case, one block is required for each physical board.

Sample time

Enter the base sample time or a multiple of the base sample time (-1 means sample time is inherited).

PCI slot (-1:autosearch)

If only one board of this type is in the target computer, enter -1 to locate the board.

If two or more boards of this type are in the target computer, enter the bus number and the PCI slot number of the board associated with this driver block. Use the format **[BusNumber, SlotNumber]**.

To determine the bus number and the PCI slot number, type:

```
tg = slrt;  
getPCIInfo(tg, 'installed')
```

External Websites

- www.ni.com

National Instruments PCI-6040E Pulse Width/Period Measurement (formerly PCI-MIO-16E-4)

PCI-6040E Pulse Width/Period Measurement block

Library

Simulink Real-Time Library for National Instruments

Note

Connect the signal you want to measure to the GATE input of the chosen counter. The signal must have fast rise and fall times; otherwise, the counter might experience false triggering. Use signal voltage levels between 0 and 5 volts (TTL levels).

Block Parameters

Counter

From the list, select a counter, 0 or 1.

Trigger mode

From the list, choose **Level Triggered** or **Edge Triggered**. See the table below for an example of how **Trigger mode** and **Polarity** interact. In this table, the data in the Output column resulted from a 1 kHz pulse train with a 25% low and a 75% high pulse.

Polarity

From the list, choose **Active low** or **Active high**. See the table below for an example of how **Trigger mode** and **Polarity** interact. In this table, the data in the Output column resulted from a 1 kHz pulse train with a 25% low and a 75% high pulse.

Measurement Objective	Trigger Mode	Polarity	Output
Pulse width (low pulse)	Level triggered	Active low	5000

Measurement Objective	Trigger Mode	Polarity	Output
Pulse width (high pulse)	Level triggered	Active high	15000
Period	Edge triggered	NA	20000

In every case, the output of the block is the number of clock ticks (of the 20 MHz source clock) required for the specified measurement. When measuring pulse width, the output reflects the number of clock ticks for which the input signal was in the specified (low or high) state. See the table above for an example.

Sample time

Enter the base sample time or a multiple of the base sample time (- 1 means sample time is inherited).

PCI slot (-1:autosearch)

If only one board of this type is in the target computer, enter - 1 to locate the board.

If two or more boards of this type are in the target computer, enter the bus number and the PCI slot number of the board associated with this driver block. Use the format **[BusNumber,SlotNumber]**.

To determine the bus number and the PCI slot number, type:

```
tg = slrt;
getPCIInfo(tg, 'installed')
```

External Websites

- www.ni.com

National Instruments PCI/PXI-6052E

Support for National Instruments PCI/PXI-6052E board

Board

National Instruments PCI/PXI-6052E

General Description

The PXI/PCI-6052E is an I/O board with 16 single or 8 differential analog input channels (16-bit) with a maximum sample rate of 333 kHz, 2 analog output channels (16-bit) and 8 digital input and output lines, and two counters/timers (24-bit) with a maximum source clock rate of 20 MHz.

The Simulink Real-Time block library supports this board with these driver blocks:

- National Instruments PXI/PCI-6052E Analog Input (A/D)
- National Instruments PXI/PCI-6052E Analog Output (D/A)
- National Instruments PXI/PCI-6052E Digital Input
- National Instruments PXI/PCI-6052E Digital Output
- National Instruments PXI/PCI-6052E Pulse Generation
- National Instruments PXI/PCI-6052E Pulse Width/Period Measurement

Board Characteristics

Board name	PXI/PCI-6052E
Manufacturer	National Instruments
Bus type	PCI/PXI
Access method	Memory mapped
Multiple block instance support	A/D: No, D/A: No, Digital I/O: Yes; Pulse Width/Period measurement: Yes; Pulse Train Generation: No

Multiple board support

Yes

External Websites

- www.ni.com

National Instruments PXI/PCI-6052E Analog Input (A/D)

PXI/PCI-6052E Analog Input block

Library

Simulink Real-Time Library for National Instruments

Scaling of Input to Output

I/O Module Input	Block Output Data Type	Scaling
Volts	Double	1

Block Parameters

Channel vector

Enter numbers between 1 and 16. This driver allows you to enter channel numbers in arbitrary order.

For example, to use the first, second, and fifth channels, enter

[1,2,5]

Number the channels beginning with 1 even if this board manufacturer starts numbering the channels with 0.

Range vector

Enter a range code for each of the channels in the channel vector. The range vector must be the same length as the channel vector. This driver allows each channel to be different.

The following table is a list of the ranges for this driver and the corresponding range codes.

Input Range (V)	Range Code
-10 to +10	-10
-5 to +5	-5
-2 to +2	-2
-1 to +1	-1
-0.5 to +0.5	-0.5
-0.2 to +0.2	-0.2
-0.1 to +0.1	-0.1
-0.05 to +0.05	-0.05
0 to +10	10
0 to +5	5
0 to +2	2
0 to +1	1
0 to +0.5	0.5
0 to +0.2	0.2
0 to +0.1	0.1

For example, if the first channel is -10 to +10 volts and the second and fifth channels are 0 to +1 volts, enter

[-10, 1, 1]

Input coupling vector

Enter a coupling code for each of the channels in the channel vector. The coupling vector must be the same length as the channel vector. This driver allows a different coupling for each channel.

The following table is a list of the couplings for this driver and the corresponding coupling codes.

Coupling	Coupling Code	Description
RSE	0	Analog input line connected to the positive input of the PGIA. Analog input ground (AIGND) internally connected to the negative input of the PGIA. See the board manual.

Coupling	Coupling Code	Description
NRSE	1	Analog input line connected to the positive input of the PGIA. Analog input sense (AISENSE) connected to the negative input of the PGIA. See the board manual.
DIFF	2	First analog input line connected to the positive input of the PGIA. Second analog input line connected to the negative input of the PGIA. See the board manual.

For example, if the first and second channels are single input and the fifth channel is a differential input, enter

```
[0,0,2]
```

The driver selects a second differential input 8 channels higher than the first channel. In the example above, the driver would select the thirteenth channel as a differential input with the fifth channel.

If the board is set up for differential mode, you can read the data from either of the channels in the differential pair. For example, if you have a differential pair of 1 and 9, you can read the data from channel 1 or channel 9. However, you might want to read the lower channel number of the pair because it remains unchanged when you switch the input mode between single-ended and differential.

Sample time

Enter the base sample time or a multiple of the base sample time (- 1 means sample time is inherited).

PCI slot (-1:autosearch)

If only one board of this type is in the target computer, enter - 1 to locate the board.

If two or more boards of this type are in the target computer, enter the bus number and the PCI slot number of the board associated with this driver block. Use the format **[BusNumber,SlotNumber]**.

To determine the bus number and the PCI slot number, type:

```
tg = slrt;
getPCIInfo(tg, 'installed')
```

External Websites

- www.ni.com

National Instruments PXI/PCI-6052E Analog Output (D/A)

PXI/PCI-6052E Analog Output block

Library

Simulink Real-Time Library for National Instruments

Scaling of Input to Output

I/O Module Output	Block Input Data Type	Scaling
Volts	Double	1

Block Parameters

Channel vector

Enter 1 or 2. This driver allows the selection of individual D/A channels in arbitrary order. The number of elements defines the number of D/A channels used. For example, to use both of the analog output channels, enter

[1,2]

Number the channels begin with 1 even if this board manufacturer starts numbering the channels with 0.

Range vector

Enter a range code for each of the channels in the channel vector. The range vector must be the same length as the channel vector. This board allows the range of each channel to be different.

The following table is a list of the ranges for this driver and the corresponding range codes.

Input Range (V)	Range Code
-10 to +10	-10

Input Range (V)	Range Code
0 to +10	10

For example, if the first channel is -10 to +10 volts and the second channel is 0 to +10 volts, enter

```
[-10, 10]
```

Reset vector

The reset vector controls the behavior of the channel at model termination. Enter a scalar or a vector that is the same length as the channel vector. If you specify a scalar value, that setting is replicated over the channel vector. If you specify a value of 1, the corresponding channel is reset to the value specified in the initial value vector. If you specify a value of 0, the channel remains at the last value attained while the model was running.

Initial value vector

The initial value vector contains the initial voltage values for the output channels. Enter a scalar or a vector that is the same length as the channel vector. If you specify a scalar value, that value is replicated as the initial value over the channel vector. The channels are set to the initial values between the time the model is downloaded and the time it is started.

Sample time

Enter the base sample time or a multiple of the base sample time (-1 means sample time is inherited).

PCI slot (-1:autosearch)

If only one board of this type is in the target computer, enter -1 to locate the board.

If two or more boards of this type are in the target computer, enter the bus number and the PCI slot number of the board associated with this driver block. Use the format **[BusNumber, SlotNumber]**.

To determine the bus number and the PCI slot number, type:

```
tg = slrt;
getPCIInfo(tg, 'installed')
```

External Websites

- www.ni.com

National Instruments PXI/PCI-6052E Digital Input

PXI/PCI-6052E Digital Input block

Library

Simulink Real-Time Library for National Instruments

Scaling of Input to Output

I/O Module Input	Block Output Data Type	Scaling
TTL	Double	TTL low = 0.0 TTL high = 1.0

Block Parameters

Channel vector

Enter numbers between 1 and 8 to select the digital input lines used with this port. This driver allows the selection of individual digital input lines in arbitrary order. The number of elements defines the number of digital lines used.

For example, to use all of the digital inputs for one port, enter

```
[1,2,3,4,5,6,7,8]
```

Number the lines beginning with 1 even if this board manufacturer starts numbering the lines with 0.

Sample time

Enter the base sample time or a multiple of the base sample time (-1 means sample time is inherited).

PCI slot (-1:autosearch)

If only one board of this type is in the target computer, enter -1 to locate the board.

If two or more boards of this type are in the target computer, enter the bus number and the PCI slot number of the board associated with this driver block. Use the format **[BusNumber,SlotNumber]**.

To determine the bus number and the PCI slot number, type:

```
tg = slrt;  
getPCIInfo(tg, 'installed')
```

External Websites

- www.ni.com

National Instruments PXI/PCI-6052E Digital Output

PXI/PCI-6052E Digital Output block

Library

Simulink Real-Time Library for National Instruments

Scaling of Input to Output

I/O Module Output	Block Input Data Type	Scaling
TTL	Double	$<0.5 = \text{TTL low}$ $\geq 0.5 = \text{TTL high}$

Block Parameters

Channel vector

Enter numbers between 1 and 8 to select the digital output lines used with this port. This driver allows the selection of individual digital output lines in arbitrary order. The number of elements defines the number of digital lines used.

For example, to use all of the digital outputs for one port, enter

```
[1,2,3,4,5,6,7,8]
```

Number the lines beginning with 1 even if this board manufacturer starts numbering the lines with 0.

Reset vector

The reset vector controls the behavior of the channel at model termination. Enter a scalar or a vector that is the same length as the channel vector. If you specify a scalar value, that setting is replicated over the channel vector. If you specify a value of 1, the corresponding channel is reset to the value specified in the initial value vector. If you specify a value of 0, the channel remains at the last value attained while the model was running.

Initial value vector

The initial value vector contains the initial values (0 or 1) of the output channels. Enter a scalar or a vector that is the same length as the channel vector. If you enter a scalar, that value is replicated as the initial value over the channel vector. The channels are set to these initial values between the time the model is downloaded and the time it is started.

Sample time

Enter the base sample time or a multiple of the base sample time (- 1 means sample time is inherited).

PCI slot (-1:autosearch)

If only one board of this type is in the target computer, enter - 1 to locate the board.

If two or more boards of this type are in the target computer, enter the bus number and the PCI slot number of the board associated with this driver block. Use the format **[BusNumber,SlotNumber]**.

To determine the bus number and the PCI slot number, type:

```
tg = slrt;  
getPCIInfo(tg, 'installed')
```

External Websites

- www.ni.com

National Instruments PXI/PCI-6052E Pulse Generation

PXI/PCI-6052E Pulse Generation

Library

Simulink Real-Time Library for National Instruments

Note

The inputs to the block should be a two-element vector. The first element is the number of counts (of the 20 MHz source clock) that the counter should maintain at a low level, and the second element is the number of clock ticks for a high level. For example, to generate a pulse train at 1 kHz with 25% low and 75% high, use the vector

```
[5000 15000]
```

Block Parameters

Counter

From the list, choose **Counter 0**, **Counter 1**, or **Both** to select the counter(s) to be used with this driver block. In each case, one block is required for each physical board.

Sample time

Enter the base sample time or a multiple of the base sample time (-1 means sample time is inherited).

PCI slot (-1:autosearch)

If only one board of this type is in the target computer, enter -1 to locate the board.

If two or more boards of this type are in the target computer, enter the bus number and the PCI slot number of the board associated with this driver block. Use the format **[BusNumber, SlotNumber]**.

To determine the bus number and the PCI slot number, type:

```
tg = slrt;  
getPCIInfo(tg, 'installed')
```

External Websites

- www.ni.com

National Instruments PXI/PCI-6052E Pulse Width/Period Measurement

PXI/PCI-6052E Pulse Width/Period Measurement

Library

Simulink Real-Time Library for National Instruments

Note

Connect the signal you want to measure to the GATE input of the chosen counter. The signal must have fast rise and fall times; otherwise, the counter might experience false triggering. Use signal voltage levels between 0 and 5 volts (TTL levels).

Block Parameters

Counter

From the list, select a counter, 0 or 1.

Trigger mode

From the list, choose **Level Triggered** or **Edge Triggered**. See the table below for an example of how **Trigger mode** and **Polarity** interact. In this table, the data in the Output column resulted from a 1 kHz pulse train with a 25% low and a 75% high pulse.

Polarity

From the list, choose **Active low** or **Active high**. See the table below for an example of how **Trigger mode** and **Polarity** interact. In this table, the data in the Output column resulted from a 1 kHz pulse train with a 25% low and a 75% high pulse.

Measurement Objective	Trigger Mode	Polarity	Output
Pulse width (low pulse)	Level triggered	Active low	5000

Measurement Objective	Trigger Mode	Polarity	Output
Pulse width (high pulse)	Level triggered	Active high	15000
Period	Edge triggered	NA	20000

In every case, the output of the block is the number of clock ticks (of the 20 MHz source clock) required for the specified measurement. When measuring pulse width, the output reflects the number of clock ticks for which the input signal was in the specified (low or high) state. See the table above for an example.

Sample time

Enter the base sample time or a multiple of the base sample time (- 1 means sample time is inherited).

PCI slot (-1:autosearch)

If only one board of this type is in the target computer, enter - 1 to locate the board.

If two or more boards of this type are in the target computer, enter the bus number and the PCI slot number of the board associated with this driver block. Use the format **[BusNumber,SlotNumber]**.

To determine the bus number and the PCI slot number, type:

```
tg = slrt;
getPCIInfo(tg, 'installed')
```

External Websites

- www.ni.com

National Instruments PCI-6070E (formerly PCI-MIO-16E-1)

Support for National Instruments PCI-6070E board

Board

National Instruments PCI-6070E

General Description

This was formerly PCI-MIO-16E-1.

The PCI-6070E is an I/O board with 16 single or 8 differential analog input channels (12-bit) with a maximum sample rate of 1.25 MHz, 2 analog output channels (12-bit), 8 digital input and output lines, and 2 counter/timers (24-bit) with a maximum source clock rate of 20 MHz.

The Simulink Real-Time block library supports this board with these driver blocks:

- National Instruments PCI-6070E Analog Input (A/D) (formerly PCI-MIO-16E-1)
- National Instruments PCI-6070E Analog Output (D/A) (formerly PCI-MIO-16E-1)
- National Instruments PCI-6070E Digital Input (formerly PCI-MIO-16E-1)
- National Instruments PCI-6070E Digital Output (formerly PCI-MIO-16E-1)
- National Instruments PCI-6070E Pulse Generation (formerly PCI-MIO-16E-1)
- National Instruments PCI-6070E Pulse Width/Period Measurement (formerly PCI-MIO-16E-1)

Board Characteristics

Board name	PCI-6070E
Manufacturer	National Instruments
Bus type	PCI

Access method

Memory mapped

Multiple block instance support

A/D: No, D/A: No, Digital I/O: Yes; Pulse
Width/Period measurement: Yes; Pulse
Train Generation: No

Multiple board support

Yes

External Websites

- www.ni.com

National Instruments PCI-6070E Analog Input (A/D) (formerly PCI-MIO-16E-1)

PCI-6070E Analog Input block

Library

Simulink Real-Time Library for National Instruments

Scaling Input to Output

I/O Module Input	Block Output Data Type	Scaling
Volts	Double	1

Block Parameters

Channel vector

Enter numbers between 1 and 16. This driver allows you to enter channel numbers in arbitrary order.

For example, to use the first, second, and fifth channels, enter

```
[1,2,5]
```

Number the channels beginning with 1 even if this board manufacturer starts numbering the channels with 0.

Range vector

Enter a range code for each of the channels in the channel vector. The range vector must be the same length as the channel vector. This driver allows each channel to be different.

The following table is a list of the ranges for this driver and the corresponding range codes.

Input Range (V)	Range Code
-10 to +10	-10
-5 to +5	-5
-2 to +2	-2
-1 to +1	-1
-0.5 to +0.5	-0.5
-0.2 to +0.2	-0.2
-0.1 to +0.1	-0.1
-0.05 to +0.05	-0.05
0 to +10	10
0 to +5	5
0 to +2	2
0 to +1	1
0 to +0.5	0.5
0 to +0.2	0.2
0 to +0.1	0.1

For example, if the first channel is -10 to +10 volts and the second and fifth channels are 0 to +1 volts, enter

[-10, 1, 1]

Input coupling vector

Enter a coupling code for each of the channels in the channel vector. The coupling vector must be the same length as the channel vector. This driver allows a different coupling for each channel.

The following table is a list of the couplings for this driver and the corresponding coupling codes.

Coupling	Coupling Code	Description
RSE	0	Analog input line connected to the positive input of the PGIA. Analog input ground (AIGND) internally connected to the negative input of the PGIA. See the board manual.

Coupling	Coupling Code	Description
NRSE	1	Analog input line connected to the positive input of the PGIA. Analog input sense (AISENSE) connected to the negative input of the PGIA. See the board manual.
DIFF	2	First analog input line connected to the positive input of the PGIA. Second analog input line connected to the negative input of the PGIA. See the board manual.

For example, if the first and second channels are single input and the fifth channel is a differential input, enter

```
[0,0,2]
```

The driver selects a second differential input 8 channels higher than the first channel. In the example above, the driver would select the thirteenth channel as a differential input with the fifth channel.

If the board is set up for differential mode, you can read the data from either of the channels in the differential pair. For example, if you have a differential pair of 1 and 9, you can read the data from channel 1 or channel 9. However, you might want to read the lower channel number of the pair because it remains unchanged when you switch the input mode between single-ended and differential.

Sample time

Enter the base sample time or a multiple of the base sample time (- 1 means sample time is inherited).

PCI slot (-1:autosearch)

If only one board of this type is in the target computer, enter - 1 to locate the board.

If two or more boards of this type are in the target computer, enter the bus number and the PCI slot number of the board associated with this driver block. Use the format **[BusNumber,SlotNumber]**.

To determine the bus number and the PCI slot number, type:

```
tg = slrt;
getPCIInfo(tg, 'installed')
```

External Websites

- www.ni.com

National Instruments PCI-6070E Analog Output (D/A) (formerly PCI-MIO-16E-1)

PCI-6070E Analog Output block

Library

Simulink Real-Time Library for National Instruments

Scaling Input to Output

I/O Module Output	Block Input Data Type	Scaling
Volts	Double	1

Block Parameters

Channel vector

Enter 1 or 2. This driver allows the selection of individual D/A channels in arbitrary order. The number of elements defines the number of D/A channels used. For example, to use both of the analog output channels, enter

[1,2]

Number the channels beginning with 1 even if this board manufacturer starts numbering the channels with 0.

Range vector

Enter a range code for each of the channels in the channel vector. The range vector must be the same length as the channel vector. This board allows the range of each channel to be different.

The following table is a list of the ranges for this driver and the corresponding range codes.

Input Range (V)	Range Code
-10 to +10	-10

Input Range (V)	Range Code
0 to +10	10

For example, if the first channel is -10 to +10 volts and the second channel is 0 to +10 volts, enter

```
[ -10, 10]
```

Reset vector

The reset vector controls the behavior of the channel at model termination. Enter a scalar or a vector that is the same length as the channel vector. If you specify a scalar value, that setting is replicated over the channel vector. If you specify a value of 1, the corresponding channel is reset to the value specified in the initial value vector. If you specify a value of 0, the channel remains at the last value attained while the model was running.

Initial value vector

The initial value vector contains the initial voltage values for the output channels. Enter a scalar or a vector that is the same length as the channel vector. If you specify a scalar value, that value is replicated as the initial value over the channel vector. The channels are set to the initial values between the time the model is downloaded and the time it is started.

Sample time

Enter the base sample time or a multiple of the base sample time (-1 means sample time is inherited).

PCI slot (-1:autosearch)

If only one board of this type is in the target computer, enter -1 to locate the board.

If two or more boards of this type are in the target computer, enter the bus number and the PCI slot number of the board associated with this driver block. Use the format **[BusNumber, SlotNumber]**.

To determine the bus number and the PCI slot number, type:

```
tg = slrt;
getPCIInfo(tg, 'installed')
```

External Websites

- www.ni.com

National Instruments PCI-6070E Digital Input (formerly PCI-MIO-16E-1)

PCI-6070E Digital Input

Library

Simulink Real-Time Library for National Instruments

Scaling Input to Output

I/O Module Input	Block Output Data Type	Scaling
TTL	Double	TTL low = 0.0 TTL high = 1.0

Block Parameters

Channel vector

Enter numbers between 1 and 8 to select the digital input lines used with this port. This driver allows the selection of individual digital input lines in arbitrary order. The number of elements defines the number of digital lines used.

For example, to use all of the digital inputs for one port, enter

```
[1,2,3,4,5,6,7,8]
```

Number the lines beginning with 1 even if this board manufacturer starts numbering the lines with 0.

Sample time

Enter the base sample time or a multiple of the base sample time (-1 means sample time is inherited).

PCI slot (-1:autosearch)

If only one board of this type is in the target computer, enter -1 to locate the board.

If two or more boards of this type are in the target computer, enter the bus number and the PCI slot number of the board associated with this driver block. Use the format **[BusNumber,SlotNumber]**.

To determine the bus number and the PCI slot number, type:

```
tg = slrt;  
getPCIInfo(tg, 'installed')
```

External Websites

- www.ni.com

National Instruments PCI-6070E Digital Output (formerly PCI-MIO-16E-1)

PCI-6070E Digital Output

Library

Simulink Real-Time Library for National Instruments

Scaling Input to Output

I/O Module Output	Block Input Data Type	Scaling
TTL	Double	$< 0.5 = \text{TTL low}$ $\geq 0.5 = \text{TTL high}$

Block Parameters

Channel vector

Enter numbers between 1 and 8 to select the digital output lines used with this port. This driver allows the selection of individual digital output lines in arbitrary order. The number of elements defines the number of digital lines used.

For example, to use all of the digital outputs for one port, enter

```
[1,2,3,4,5,6,7,8]
```

Number the lines beginning with 1 even if this board manufacturer starts numbering the lines with 0.

Reset vector

The reset vector controls the behavior of the channel at model termination. Enter a scalar or a vector that is the same length as the channel vector. If you specify a scalar value, that setting is replicated over the channel vector. If you specify a value of 1, the corresponding channel is reset to the value specified in the initial value vector.

If you specify a value of 0, the channel remains at the last value attained while the model was running.

Initial value vector

The initial value vector contains the initial values (0 or 1) of the output channels. Enter a scalar or a vector that is the same length as the channel vector. If you enter a scalar, that value is replicated as the initial value over the channel vector. The channels are set to these initial values between the time the model is downloaded and the time it is started.

Sample time

Enter the base sample time or a multiple of the base sample time (- 1 means sample time is inherited).

PCI slot (-1:autosearch)

If only one board of this type is in the target computer, enter - 1 to locate the board.

If two or more boards of this type are in the target computer, enter the bus number and the PCI slot number of the board associated with this driver block. Use the format **[BusNumber, SlotNumber]**.

To determine the bus number and the PCI slot number, type:

```
tg = slrt;  
getPCIInfo(tg, 'installed')
```

External Websites

- www.ni.com

National Instruments PCI-6070E Pulse Generation (formerly PCI-MIO-16E-1)

PCI-6070E Pulse Generation

Library

Simulink Real-Time Library for National Instruments

Note

The inputs to the block should be a two-element vector. The first element is the number of counts (of the 20 MHz source clock) that the counter should maintain at a low level, and the second element is the number of clock ticks for a high level. For example, to generate a pulse train at 1 kHz with 25% low and 75% high, use the vector

```
[5000 15000]
```

Block Parameters

Counter

From the list, choose **Counter 0**, **Counter 1**, or **Both** to select the counter(s) to be used with this driver block. In each case, one block is required for each physical board.

Sample time

Enter the base sample time or a multiple of the base sample time (-1 means sample time is inherited).

PCI slot (-1:autosearch)

If only one board of this type is in the target computer, enter -1 to locate the board.

If two or more boards of this type are in the target computer, enter the bus number and the PCI slot number of the board associated with this driver block. Use the format **[BusNumber, SlotNumber]**.

To determine the bus number and the PCI slot number, type:

```
tg = slrt;  
getPCIInfo(tg, 'installed')
```

External Websites

- www.ni.com

National Instruments PCI-6070E Pulse Width/Period Measurement (formerly PCI-MIO-16E-1)

PCI-6070E Pulse Width/Period Measurement

Library

Simulink Real-Time Library for National Instruments

Note

Connect the signal you want to measure to the GATE input of the chosen counter. The signal must have fast rise and fall times; otherwise, the counter might experience false triggering. Use signal voltage levels between 0 and 5 volts (TTL levels).

Block Parameters

Counter

From the list, select a counter, 0 or 1.

Trigger mode

From the list, choose **Level Triggered** or **Edge Triggered**. See the table below for an example of how **Trigger mode** and **Polarity** interact. In this table, the data in the Output column resulted from a 1 kHz pulse train with a 25% low and a 75% high pulse.

Polarity

From the list, choose **Active low** or **Active high**. See the table below for an example of how **Trigger mode** and **Polarity** interact. In this table, the data in the Output column resulted from a 1 kHz pulse train with a 25% low and a 75% high pulse.

Measurement Objective	Trigger Mode	Polarity	Output
Pulse width (low pulse)	Level triggered	Active low	5000

Measurement Objective	Trigger Mode	Polarity	Output
Pulse width (high pulse)	Level triggered	Active high	15000
Period	Edge triggered	NA	20000

In every case, the output of the block is the number of clock ticks (of the 20 MHz source clock) required for the specified measurement. When measuring pulse width, the output reflects the number of clock ticks for which the input signal was in the specified (low or high) state. See the table above for an example.

Sample time

Enter the base sample time or a multiple of the base sample time (- 1 means sample time is inherited).

PCI slot (-1:autosearch)

If only one board of this type is in the target computer, enter - 1 to locate the board.

If two or more boards of this type are in the target computer, enter the bus number and the PCI slot number of the board associated with this driver block. Use the format **[BusNumber,SlotNumber]**.

To determine the bus number and the PCI slot number, type:

```
tg = slrt;
getPCIInfo(tg, 'installed')
```

External Websites

- www.ni.com

National Instruments PCI-6071E

Support for National Instruments PCI-6071E board

Board

National Instruments PCI-6071E

General Description

The PCI-6071E is an I/O board with 64 single or 32 differential analog input (A/D) channels (12-bit) with a maximum sample rate of 1.25 MHz, 2 analog output (D/A) channels (12-bit), 8 digital input and output lines, and 2 counter/timers (24-bit) with a maximum source clock rate of 20 MHz.

The Simulink Real-Time block library supports this board with these driver blocks:

- National Instruments PCI-6071E Analog Input (A/D)
- National Instruments PCI-6071E Analog Output (D/A)
- National Instruments PCI-6071E Digital Input
- National Instruments PCI-6071E Digital Output
- National Instruments PCI-6071E Pulse Generation
- National Instruments PCI-6071E Pulse Width/Period Measurement

Board Characteristics

Board Name	PCI-6071E
Manufacturer	National Instruments
Bus type	PCI
Access method	Memory mapped
Multiple block instance support	A/D: No, D/A: No, Digital I/O: Yes; Pulse Width/Period measurement: Yes; Pulse Train Generation: No

Multiple board support

Yes

External Websites

- www.ni.com

National Instruments PCI-6071E Analog Input (A/D)

PCI-6071E Analog Input (A/D)

Library

Simulink Real-Time Library for National Instruments

Scaling Input to Output

I/O Module Input	Block Output Data Type	Scaling
Volts	Double	1

Block Parameters

Channel vector

Enter numbers between 1 and 64. This driver allows you to enter channel numbers in arbitrary order.

For example, to use the first, second, and fifth channels, enter

```
[1,2,5]
```

Number the channels beginning with 1 even if this board manufacturer starts numbering the channels with 0.

Range vector

Enter a range code for each of the channels in the channel vector. The range vector must be the same length as the channel vector. This driver allows each channel to be different.

The following table is a list of the ranges for this driver and the corresponding range codes.

Input Range (V)	Range Code
-10 to +10	-10

Input Range (V)	Range Code
-5 to +5	-5
-2 to +2	-2
-1 to +1	-1
-0.5 to +0.5	-0.5
-0.2 to +0.2	-0.2
-0.1 to +0.1	-0.1
-0.05 to +0.05	-0.05
0 to +10	10
0 to +5	5
0 to +2	2
0 to +1	1
0 to +0.5	0.5
0 to +0.2	0.2
0 to +0.1	0.1

For example, if the first channel is -10 to +10 volts and the second and fifth channels are 0 to +1 volts, enter

[-10, 1, 1]

Input coupling vector

Enter a coupling code for each of the channels in the channel vector. The coupling vector must be the same length as the channel vector. This driver allows a different coupling for each channel.

The following table is a list of the couplings for this driver and the corresponding coupling codes.

Coupling	Coupling Code	Description
RSE	0	Analog input line connected to the positive input of the PGIA. Analog input ground (AIGND) internally connected to the negative input of the PGIA. See the board manual.

Coupling	Coupling Code	Description
NRSE	1	Analog input line connected to the positive input of the PGIA. Analog input sense (AISENSE) connected to the negative input of the PGIA. See the board manual.
DIFF	2	First analog input line connected to the positive input of the PGIA. Second analog input line connected to the negative input of the PGIA. See the board manual.

For example, if the first and second channels are single input and the fifth channel is a differential input, enter

```
[0,0,2]
```

The driver selects a second differential input 8 channels higher than the first channel. In the example above, the driver would select the thirteenth channel as a differential input with the fifth channel.

If the board is set up for differential mode, you can read the data from either of the channels in the differential pair. For example, if you have a differential pair of 1 and 9, you can read the data from channel 1 or channel 9. However, you might want to read the lower channel number of the pair because it remains unchanged when you switch the input mode between single-ended and differential.

Sample time

Enter the base sample time or a multiple of the base sample time (- 1 means sample time is inherited).

PCI slot (-1:autosearch)

If only one board of this type is in the target computer, enter - 1 to locate the board.

If two or more boards of this type are in the target computer, enter the bus number and the PCI slot number of the board associated with this driver block. Use the format **[BusNumber,SlotNumber]**.

To determine the bus number and the PCI slot number, type:

```
tg = slrt;
getPCIInfo(tg, 'installed')
```

External Websites

- www.ni.com

National Instruments PCI-6071E Analog Output (D/A)

PCI-6071E Analog Output block

Library

Simulink Real-Time Library for National Instruments

Scaling Input to Output

I/O Module Output	Block Input Data Type	Scaling
Volts	Double	1

Block Parameters

Channel vector

Enter 1 or 2. This driver allows the selection of individual D/A channels in arbitrary order. The number of elements defines the number of D/A channels used. For example, to use both of the analog output channels, enter

[1,2]

Number the channels beginning with 1 even if this board manufacturer starts numbering the channels with 0.

Range vector

Enter a range code for each of the channels in the channel vector. The range vector must be the same length as the channel vector. This board allows the range of each channel to be different.

The following table is a list of the ranges for this driver and the corresponding range codes.

Input Range (V)	Range Code
-10 to +10	-10

Input Range (V)	Range Code
0 to +10	10

For example, if the first channel is -10 to +10 volts and the second channel is 0 to +10 volts, enter

```
[-10, 10]
```

Reset vector

The reset vector controls the behavior of the channel at model termination. Enter a scalar or a vector that is the same length as the channel vector. If you specify a scalar value, that setting is replicated over the channel vector. If you specify a value of 1, the corresponding channel is reset to the value specified in the initial value vector. If you specify a value of 0, the channel remains at the last value attained while the model was running.

Initial value vector

The initial value vector contains the initial voltage values for the output channels. Enter a scalar or a vector that is the same length as the channel vector. If you specify a scalar value, that value is replicated as the initial value over the channel vector. The channels are set to the initial values between the time the model is downloaded and the time it is started.

Sample time

Enter the base sample time or a multiple of the base sample time (-1 means sample time is inherited).

PCI slot (-1:autosearch)

If only one board of this type is in the target computer, enter -1 to locate the board.

If two or more boards of this type are in the target computer, enter the bus number and the PCI slot number of the board associated with this driver block. Use the format **[BusNumber, SlotNumber]**.

To determine the bus number and the PCI slot number, type:

```
tg = slrt;
getPCIInfo(tg, 'installed')
```

External Websites

- www.ni.com

National Instruments PCI-6071E Digital Input

PCI-6071E Digital Input block

Library

Simulink Real-Time Library for National Instruments

Scaling Input to Output

I/O Module Input	Block Output Data Type	Scaling
TTL	Double	TTL low = 0.0 TTL high = 1.0

Block Parameters

Channel vector

Enter numbers between 1 and 8 to select the digital input lines used with this port. This driver allows the selection of individual digital input lines in arbitrary order. The number of elements defines the number of digital lines used.

For example, to use all of the digital inputs for one port, enter

```
[1,2,3,4,5,6,7,8]
```

Number the lines beginning with 1 even if this board manufacturer starts numbering the lines with 0.

Sample time

Enter the base sample time or a multiple of the base sample time (-1 means sample time is inherited).

PCI slot (-1:autosearch)

If only one board of this type is in the target computer, enter -1 to locate the board.

If two or more boards of this type are in the target computer, enter the bus number and the PCI slot number of the board associated with this driver block. Use the format **[BusNumber,SlotNumber]**.

To determine the bus number and the PCI slot number, type:

```
tg = slrt;  
getPCIInfo(tg, 'installed')
```

External Websites

- www.ni.com

National Instruments PCI-6071E Digital Output

PCI-6071E Digital Output block

Library

Simulink Real-Time Library for National Instruments

Scaling Input to Output

I/O Module Output	Block Input Data Type	Scaling
TTL	Double	$< 0.5 = \text{TTL low}$ $\geq 0.5 = \text{TTL high}$

Block Parameters

Channel vector

Enter numbers between 1 and 8 to select the digital output lines used with this port. This driver allows the selection of individual digital output lines in arbitrary order. The number of elements defines the number of digital lines used.

For example, to use all of the digital outputs for one port, enter

```
[1,2,3,4,5,6,7,8]
```

Number the lines beginning with 1 even if this board manufacturer starts numbering the lines with 0.

Reset vector

The reset vector controls the behavior of the channel at model termination. Enter a scalar or a vector that is the same length as the channel vector. If you specify a scalar value, that setting is replicated over the channel vector. If you specify a value of 1, the corresponding channel is reset to the value specified in the initial value vector. If you specify a value of 0, the channel remains at the last value attained while the model was running.

Initial value vector

The initial value vector contains the initial values (0 or 1) of the output channels. Enter a scalar or a vector that is the same length as the channel vector. If you enter a scalar, that value is replicated as the initial value over the channel vector. The channels are set to these initial values between the time the model is downloaded and the time it is started.

Sample time

Enter the base sample time or a multiple of the base sample time (- 1 means sample time is inherited).

PCI slot (-1:autosearch)

If only one board of this type is in the target computer, enter - 1 to locate the board.

If two or more boards of this type are in the target computer, enter the bus number and the PCI slot number of the board associated with this driver block. Use the format **[BusNumber,SlotNumber]**.

To determine the bus number and the PCI slot number, type:

```
tg = slrt;  
getPCIInfo(tg, 'installed')
```

External Websites

- www.ni.com

National Instruments PCI-6071E Pulse Generation

PCI-6071E Pulse Generation block

Library

Simulink Real-Time Library for National Instruments

Note

The inputs to the block should be a two-element vector. The first element is the number of counts (of the 20 MHz source clock) that the counter should maintain at a low level, and the second element is the number of clock ticks for a high level. For example, to generate a pulse train at 1 kHz with 25% low and 75% high, use the vector

```
[5000 15000]
```

Block Parameters

Counter

From the list, choose **Counter 0**, **Counter 1**, or **Both** to select the counter(s) to be used with this driver block. In each case, one block is required for each physical board.

Sample time

Enter the base sample time or a multiple of the base sample time (- 1 means sample time is inherited).

PCI slot (-1:autosearch)

If only one board of this type is in the target computer, enter - 1 to locate the board.

If two or more boards of this type are in the target computer, enter the bus number and the PCI slot number of the board associated with this driver block. Use the format **[BusNumber, SlotNumber]**.

To determine the bus number and the PCI slot number, type:

```
tg = slrt;  
getPCIInfo(tg, 'installed')
```

External Websites

- www.ni.com

National Instruments PCI-6071E Pulse Width/Period Measurement

PCI-6071E Pulse Width/Period Measurement block

Library

Simulink Real-Time Library for National Instruments

Note

Connect the signal you want to measure to the GATE input of the chosen counter. The signal must have fast rise and fall times; otherwise, the counter might experience false triggering. Use signal voltage levels between 0 and 5 volts (TTL levels).

Block Parameters

Counter

From the list, select a counter, 0 or 1.

Trigger mode

From the list, choose **Level Triggered** or **Edge Triggered**. See the table below for an example of how **Trigger mode** and **Polarity** interact. In this table, the data in the Output column resulted from a 1 kHz pulse train with a 25% low and a 75% high pulse.

Polarity

From the list, choose **Active low** or **Active high**. See the table below for an example of how **Trigger mode** and **Polarity** interact. In this table, the data in the Output column resulted from a 1 kHz pulse train with a 25% low and a 75% high pulse.

Measurement Objective	Trigger Mode	Polarity	Output
Pulse width (low pulse)	Level triggered	Active low	5000

Measurement Objective	Trigger Mode	Polarity	Output
Pulse width (high pulse)	Level triggered	Active high	15000
Period	Edge triggered	NA	20000

In every case, the output of the block is the number of clock ticks (of the 20 MHz source clock) required for the specified measurement. When measuring pulse width, the output reflects the number of clock ticks for which the input signal was in the specified (low or high) state. See the table above for an example.

Sample time

Enter the base sample time or a multiple of the base sample time (- 1 means sample time is inherited).

PCI slot (-1:autosearch)

If only one board of this type is in the target computer, enter - 1 to locate the board.

If two or more boards of this type are in the target computer, enter the bus number and the PCI slot number of the board associated with this driver block. Use the format **[BusNumber,SlotNumber]**.

To determine the bus number and the PCI slot number, type:

```
tg = slrt;  
getPCIInfo(tg, 'installed')
```

External Websites

- www.ni.com

National Instruments PCI-6221

Support for PCI-6221 and PXI-6221 boards

Board

National Instruments PCI-6221, PXI-6221

General Description

The 6221 M-series boards are data acquisition I/O boards with up to 16 single-ended or 8 differential 16-bit analog inputs, two 16-bit analog outputs, 24 digital I/O lines, and two 32-bit counters.

The Simulink Real-Time block library supports the 6221 boards with these driver blocks:

- National Instruments PCI-6221 Analog Input
- National Instruments PCI-6221 Analog Output
- National Instruments PCI-6221 Digital Input
- National Instruments PCI-6221 Digital Output
- National Instruments PCI-6221 Incremental Encoder
- National Instruments PCI-6221 PFI Digital Input
- National Instruments PCI-6221 PFI Digital Output
- National Instruments PCI-6221 PWM Generate
- National Instruments PCI-6221 PWM Measure

Board Characteristics

Board name	PCI-6221, PXI-6221
Manufacturer	National Instruments
Bus type	PCI, PXI (both use PCI version of blocks)
Multiple block instance support	A/D: No, D/A: No, Digital I/O: Yes

Multiple board support

Yes

External Websites

- www.ni.com

National Instruments PCI-6221 Analog Input

Analog Input block for PCI-6221 and PXI-6221 boards

Library

Simulink Real-Time Library for National Instruments

Scaling of Input to Output

I/O Module Input	Block Output Data Type	Scaling
Volts	Double	1

Block Parameters

Channel vector

Enter numbers from 1 through 16. This driver allows you to enter channel numbers in arbitrary order.

For example, to use the first, second, and fifth channels, enter

```
[1,2,5]
```

Number the lines beginning with 1 even if this board manufacturer starts numbering the lines with 0.

Range vector

Enter a range code for each of the channels in the channel vector. You can specify one value to replicate over the channel vector, or specify one for each channel. This driver allows each channel to be different. This board works only in bipolar mode.

The following table is a list of the ranges for this driver and the corresponding range codes.

Input Range (V)	Range Code
-10 to +10	10
-5 to +5	5
-1 to +1	1
-0.2 to +0.2	0.2

For example, if the first channel is -10 volts to +10 volts and the second and fifth channels are -1 volts to +1 volts, enter

[10, 1, 1]

Input coupling vector

Enter a coupling code for each of the channels in the channel vector. You can replicate one value over the channel vector, or specify one for each channel. This driver allows a different coupling for each channel.

The following table is a list of the couplings for this driver and the corresponding coupling codes.

Coupling	Coupling Code	Description
RSE	0	Analog input line connected to the positive input of the PGIA. Analog input ground (AIGND) internally connected to the negative input of the PGIA. See the National Instruments user manual.
NRSE	1	Analog input line connected to the positive input of the PGIA. Analog input sense (AISENSE) connected to the negative input of the PGIA. See the National Instruments user manual.
DIFF	2	First analog input line connected to the positive input of the PGIA. Second analog input line connected to the negative input of the PGIA. See the National Instruments user manual.

For example, if the first and second channels are single input and the fifth channel is a differential input, enter

[0, 0, 2]

National Instruments boards use a zero-based number scheme for differential mode channel pairs. Simulink Real-Time drivers use a one-based number scheme that adds a 1 to the I/O module number, as shown in the following table:

Zero-Based Channel Number		One-Based Channel Number	
+	-	+	-
0	8	1	9
1	9	2	10
2	10	3	11
3	11	4	12
4	12	5	13
5	13	6	14
6	14	7	15
7	15	8	16

The I/O module uses a second input 8 channels higher than the first channel as the negative input of the pair. In the example above, the I/O module would use the 13th channel as a differential input with the fifth channel.

If the module is set up for differential mode, you can read the data from either of the channels in the differential pair. For example, if you have a differential pair of 1 and 9, you can read the data from channel 1 or channel 9. However, you might want to read the lower channel number of the pair because it remains unchanged when you switch the input mode between single-ended and differential.

Scan interval

If **Channel vector** has more than one channel in it, enter the time between sampling different channels. Because execution waits for data to be available, this value increases the time to execute the block. If you enter a shorter time, you get the minimum of 4e-6, which is the fastest this board can acquire data. If you enter a time smaller than this value, the time will still be 4e-6. See the National Instruments user manual for a discussion about settling time and the need to control the time between sampling different channels depending on the impedance of the signal source.

Sample time

Enter the base sample time or a multiple of the base sample time (-1 means sample time is inherited).

PCI slot (-1:autosearch)

If only one board of this type is in the target computer, enter - 1 to locate the board.

If two or more boards of this type are in the target computer, enter the bus number and the PCI slot number of the board associated with this driver block. Use the format **[BusNumber,SlotNumber]**.

To determine the bus number and the PCI slot number, type:

```
tg = slrt;  
getPCIInfo(tg, 'installed')
```

External Websites

- www.ni.com

National Instruments PCI-6221 Analog Output

Analog Output block for PCI-6221 and PXI-6221 boards

Library

Simulink Real-Time Library for National Instruments

Scaling of Output to Input

I/O Module Output	Block Input Data Type	Scaling
Volts	Double	1

Block Parameters

Channel vector

Enter 1 or 2. This driver allows the selection of individual D/A channels in arbitrary order. The number of elements defines the number of D/A channels used. For example, to use both of the analog output channels, enter

[1,2]

Number the channels beginning with 1 even if this board manufacturer starts numbering the channels with 0.

Reset vector

The reset vector controls the behavior of the channel at model termination. Enter a scalar or a vector that is the same length as the channel vector. If you specify a scalar value, that setting is replicated over the channel vector. If you specify a value of 1, the corresponding channel is reset to the value specified in the initial value vector. If you specify a value of 0, the channel remains at the last value attained while the model was running.

Initial value vector

The initial value vector contains the initial voltage values for the output channels. Enter a scalar or a vector that is the same length as the channel vector. If you specify

a scalar value, that value is replicated as the initial value over the channel vector. The channels are set to the initial values between the time the model is downloaded and the time it is started.

Sample time

Enter the base sample time or a multiple of the base sample time (- 1 means sample time is inherited).

PCI slot (-1:autosearch)

If only one board of this type is in the target computer, enter - 1 to locate the board.

If two or more boards of this type are in the target computer, enter the bus number and the PCI slot number of the board associated with this driver block. Use the format **[BusNumber,SlotNumber]**.

To determine the bus number and the PCI slot number, type:

```
tg = slrt;  
getPCIInfo(tg, 'installed')
```

External Websites

- www.ni.com

National Instruments PCI-6221 Digital Input

Digital Input block for PCI-6221 and PXI-6221 boards

Library

Simulink Real-Time Library for National Instruments

Note

Models can have multiple digital input blocks for one physical board. In this case, the Simulink Real-Time environment executes the blocks based on their sorted order as determined by the Simulink software.

Each board has one set of static digital I/O ports. You can independently configure each port to be input or output.

If a digital input block shares channels with a digital output block, the input block reads the last value written to the digital output block on the overlapping channels.

Scaling of Input to Output

I/O Module Input	Block Output Data Type	Scaling
TTL	Double	TTL low ≥ 0.0 TTL high = 1.0

Block Parameters

Channel vector

Enter numbers between 1 and 8 to select the digital input lines used with this port. This driver allows the selection of individual digital input lines in arbitrary order. The number of elements defines the number of digital lines used.

For example, to use the first eight digital inputs for one port, enter

[1,2,3,4,5,6,7,8]

Number the lines beginning with 1 even if this board manufacturer starts numbering the lines with 0.

Sample time

Enter the base sample time or a multiple of the base sample time (- 1 means sample time is inherited).

PCI slot (-1:autosearch)

If only one board of this type is in the target computer, enter - 1 to locate the board.

If two or more boards of this type are in the target computer, enter the bus number and the PCI slot number of the board associated with this driver block. Use the format **[BusNumber,SlotNumber]**.

To determine the bus number and the PCI slot number, type:

```
tg = slrt;  
getPCIInfo(tg, 'installed')
```

External Websites

- www.ni.com

National Instruments PCI-6221 Digital Output

Digital Output block for PCI-6221 and PXI-6221 boards

Library

Simulink Real-Time Library for National Instruments

Note

Models can have multiple digital output blocks for one physical board. In this case, the Simulink Real-Time environment executes the blocks based on their sorted order as determined by the Simulink software.

Each board has one set of digital I/O ports. You can independently configure each port to be input or output.

If a digital input block shares channels with a digital output block, the input block reads the last value written to the digital output block on the overlapping channels.

The block compares the value written to each port with 0.5.

Value written	Block writes digital output with a value of...
≥ 0.5	1
< 0.5	0

Scaling of Output to Input

I/O Module Output	Block Input Data Type	Scaling
TTL	Double	$< 0.5 = \text{TTL low}$ $\geq 0.5 = \text{TTL high}$

Block Parameters

Channel vector

Enter numbers between 1 and 8 to select the digital output lines used with this port. This driver allows the selection of individual digital output lines in arbitrary order. The number of elements defines the number of digital lines used.

For example, to use the first eight digital outputs, enter

```
[1,2,3,4,5,6,7,8]
```

Number the lines beginning with 1 even if this board manufacturer starts numbering the lines with 0.

Reset vector

The reset vector controls the behavior of the channel at model termination. Enter a scalar or a vector that is the same length as the channel vector. If you specify a scalar value, that setting is replicated over the channel vector. If you specify a value of 1, the corresponding channel is reset to the value specified in the initial value vector. If you specify a value of 0, the channel remains at the last value attained while the model was running.

Initial value vector

The initial value vector contains the initial values (0 or 1) of the output channels. Enter a scalar or a vector that is the same length as the channel vector. If you enter a scalar, that value is replicated as the initial value over the channel vector. The channels are set to these initial values between the time the model is downloaded and the time it is started.

Sample time

Enter the base sample time or a multiple of the base sample time (- 1 means sample time is inherited).

PCI slot (-1:autosearch)

If only one board of this type is in the target computer, enter - 1 to locate the board.

If two or more boards of this type are in the target computer, enter the bus number and the PCI slot number of the board associated with this driver block. Use the format [**BusNumber**,**SlotNumber**].

To determine the bus number and the PCI slot number, type:

```
tg = slrt;  
getPCIInfo(tg, 'installed')
```

External Websites

- www.ni.com

National Instruments PCI-6221 Incremental Encoder

Incremental Encoder block for PCI-6221 and PXI-6221 boards

Library

Simulink Real-Time Library for National Instruments

Scaling Input to Output

I/O Module Input	Block Output Data Type	Scaling
TTL level quadrature encoder signals	Double	counts

Block Parameters

Channel

From the list, choose 0 or 1 for the channel counter you want to use. For information on input for these counters, see the National Instruments M Series user manual. The pin associations are:

Counter	Channel 0	Channel 1
A	PFI 8 (Pin 37)	PFI 3 (Pin 42)
B	PFI 10 (Pin 45)	PFI 11 (Pin 46)
Z	PFI 9 (Pin 3)	PFI 4 (Pin 41)

Counting mode

From the list, select a counting mode:

Mode	Description
Quadrature Mode x1	Count on rising edges of the A signal
Quadrature Mode x2	Count on both rising and falling edges of the A signal

Mode	Description
Quadrature Mode x4	Count on both rising and falling edges of both A and B signals

The level of the opposite signal when an edge occurs determines the count direction. For example, a rising edge of A when B is high counts one way, while an edge of A when B is low counts the other. For more information, see the National Instruments M Series user manual.

Initial count

The initial count specifies the initial value for the counter. The block resets the count to this value under the following conditions:

- When the model starts
- When the following is true, which typically occurs once per revolution for a rotary encoder.
 - **Reload at index pulse** check box is selected
 - Index pulse (Z input) is true
 - The phases of A and B match the setting of **Index phase**

Reload at index pulse

Select this check box to reset the counter to the value of **Initial count** at each index pulse. The reset occurs when:

- The encoder outputs a high level on its index output
- The phases of A and B match the setting of **Index phase**

Index phase

If you have selected the **Reload at index pulse** check box, the **Index phase** parameter specifies the phase of the quadrature signals during which the count reloads with **Initial count**. Your choice of value primarily depends on the particular incremental encoder you use. From the list, select one:

- A low B low
- A low B high
- A high B low
- A high B high

To choose an **Index phase** value for reset, use an oscilloscope, triggered on the index pulse, to observe the states of counters A and B. If your choice does not meet the encoder requirements, resets may be inconsistent.

Filter

You can apply a digital debouncing filter to the input pins before processing.

From the list, select a filter value to ignore pulses that are shorter than the filter time. The value of **NONE** indicates that the input is not filtered.

- None
- Minimum pulse width 125 nanoseconds
- Minimum pulse width 6.25 microseconds
- Minimum pulse width 1.25 milliseconds

Sample time

Enter the base sample time or a multiple of the base sample time (- 1 means sample time is inherited).

PCI slot (-1:autosearch)

If only one board of this type is in the target computer, enter - 1 to locate the board.

If two or more boards of this type are in the target computer, enter the bus number and the PCI slot number of the board associated with this driver block. Use the format **[BusNumber, SlotNumber]**.

To determine the bus number and the PCI slot number, type:

```
tg = slrt;  
getPCIInfo(tg, 'installed')
```

External Websites

- www.ni.com

National Instruments PCI-6221 PFI Digital Input

PFI Digital Input block for PCI-6221 and PXI-6221 boards

Library

Simulink Real-Time Library for National Instruments

Description

A model can have more than one PFI digital input block for a given physical board. If a model has more than one digital input block, it executes the blocks in the order that the Simulink software has determined.

The two counters and the PFI digital input and output blocks share the 16 PFI digital I/O lines. Follow these rules when using these blocks:

You can read a PFI bit with this digital input block when...	You cannot read a PFI bit with this digital input block when...
PWM measure block is using the bit	PWM generate block is using the bit
Incremental encoder block is using the bit	PFI digital output block is using the bit

Scaling of Input to Output

I/O Module Input	Block Output Data Type	Scaling
TTL	Double	TTL low ≥ 0.0 TTL high = 1.0

Block Parameters

PFI bit vector (0-15)

This block uses 0 based numbering to reflect the names of the bits described in the National Instruments M Series user manual.

Enter a vector that contains the bits you want to monitor. For example, to read bits PFI 0, PFI 5, and PFI 7, enter

```
[0, 5, 7]
```

Sample time

Enter the base sample time or a multiple of the base sample time (- 1 means sample time is inherited).

PCI slot (-1:autosearch)

If only one board of this type is in the target computer, enter - 1 to locate the board.

If two or more boards of this type are in the target computer, enter the bus number and the PCI slot number of the board associated with this driver block. Use the format **[BusNumber, SlotNumber]**.

To determine the bus number and the PCI slot number, type:

```
tg = slrt;  
getPCIInfo(tg, 'installed')
```

External Websites

- www.ni.com

National Instruments PCI-6221 PFI Digital Output

PFI Digital Output block for PCI-6221 and PXI-6221 boards

Library

Simulink Real-Time Library for National Instruments

Description

A model can have more than one PFI digital input block for a given physical board. If a model has more than one digital input block, it executes the blocks in the order that the Simulink software has determined.

The two counters and the PFI digital input and output blocks share the 16 PFI digital I/O lines. Follow these rules when using these blocks:

- Do not use a PFI bit as a digital output when the PDF digital input block is using the bit.
- Do not use a PFI bit as a digital output when the incremental encoder is using the bit.
- Do not use a PFI bit for digital output when the PWM generate block is using the bit.

Scaling of Output to Input

I/O Module Output	Block Input Data Type	Scaling
TTL	Double	$< 0.5 = \text{TTL low}$ $\geq 0.5 = \text{TTL high}$

Block Parameters

PFI bit vector (0-15)

This block uses 0 based numbering to reflect the names of the bits described in the National Instruments M Series user manual.

Enter a vector that contains the bits you want to control. For example, to write bits PFI 1, PFI 3, and PFI 9, enter

```
[1, 3, 9]
```

Reset vector

The reset vector controls the behavior of the channel at model termination. Enter a scalar or a vector that is the same length as the channel vector. If you specify a scalar value, that setting is replicated over the channel vector. If you specify a value of 1, the corresponding channel is reset to the value specified in the initial value vector. If you specify a value of 0, the channel remains at the last value attained while the model was running.

Initial value vector

The initial value vector contains the initial values (0 or 1) of the block outputs. Enter a scalar or a vector of values, one for each output. If you enter a scalar, the driver replicates that value over the output vector.

The block applies this value as follows:

- The model uses this value when you first download the model to the target computer.
- If you set **Reset vector** to 1, the block output is reset to this value when model execution stops. If the value is greater than 0.5, the block sets output to **HIGH**. If the value is less than or equal to 0.5, the block sets the output to **LOW**.

Sample time

Enter the base sample time or a multiple of the base sample time (-1 means sample time is inherited).

PCI slot (-1:autosearch)

If only one board of this type is in the target computer, enter -1 to locate the board.

If two or more boards of this type are in the target computer, enter the bus number and the PCI slot number of the board associated with this driver block. Use the format [**BusNumber**, **SlotNumber**].

To determine the bus number and the PCI slot number, type:

```
tg = slrt;
getPCIInfo(tg, 'installed')
```

External Websites

- www.ni.com

National Instruments PCI-6221 PWM Generate

PWM Generate block for PCI-6221 and PXI-6221 boards

Library

Simulink Real-Time Library for National Instruments

Description

Use this block to generate variable frequency and pulse width output.

The M Series boards have two 32-bit counters that you can use to generate pulse trains. Inputs are in counts of the 80 MHz reference frequency on the onboard clock.

- H input is the number of counts that the output is high.
- L input is the number of counts that the output is low.

If the H input goes to 0, the output stays low. If the L input goes to 0, the output stays high. If both are 0, the output goes low.

Block Parameters

Counter

From the list, select the counter, 0 or 1, that you want to use. The output for these counters is on the following pins:

Counter	Pin
0	PFI 12 (Pin 2)
1	PFI 13 (Pin 40)

Initial high count

Enter the number of counts the output is high between the time the Simulink engine calls the `mdlStart` routine for this block and the first time it calls `mdlOutputs`. This

length of time depends on the number of blocks in the model and the sorted order as determined by the Simulink software.

If you enter a value of 0, the output stays low until the first time the Simulink engine calls `mdlOutputs`.

Initial low count

Enter the number of counts the output is low between the time the Simulink engine calls the `mdlStart` routine for this block and the first time it calls `mdlOutputs`. This length of time depends on the number of blocks in the model and the sorted order as determined by the Simulink software. If you enter a value of 0, the output stays high until the first time the Simulink engine calls `mdlOutputs`, unless you have also set `H` to 0.

Arm input

Select this check box to add a third input port to the block.

- If the input connected to this port is greater than 0.5, the block arms the counter. Output then occurs.
- If the input connected to this port is less than or equal to 0.5, the block disarms the counter and the output goes to the level of the value in the **Disarm level** parameter.

Disarm level

From the list, select the disarm level **Disarm to LOW** or **Disarm to HIGH**. If the model disarms the block and the level of the value is **Arm input**, the output goes to the level you select here.

Stop level

From the list, select the stop level **Stop to LOW** or **Stop to HIGH**. When model execution stops, the output goes to the level you choose here.

Sample time

Enter the base sample time or a multiple of the base sample time (-1 means sample time is inherited).

PCI slot (-1:autosearch)

If only one board of this type is in the target computer, enter -1 to locate the board.

If two or more boards of this type are in the target computer, enter the bus number and the PCI slot number of the board associated with this driver block. Use the format **[BusNumber, SlotNumber]**.

To determine the bus number and the PCI slot number, type:

```
tg = slrt;  
getPCIInfo(tg, 'installed')
```

External Websites

- www.ni.com

National Instruments PCI-6221 PWM Measure

PWM Measure block for PCI-6221 and PXI-6221 boards

Library

Simulink Real-Time Library for National Instruments

Description

Use this block to measure the pulse width or the period of a signal.

To measure the pulse width of a signal, connect the signal to the gate, as follows:

Counter	Gate Pin
0	PFI 9 (Pin 3)
1	PFI 4 (Pin 41)

The input waveform must have fast rise and fall times and conform to TTL signal levels of [0,5] volts. Use external signal conditioning to achieve these levels. If you input a sine wave, the decision points are less definite and the measurement is noisy. In extreme cases, the gate can transition multiple times during a slow signal transition.

This block does not queue or buffer measurements. If the gate changes state, the driver holds the current count, overwriting the previous value.

This block returns the length of the last gate period before the block executes.

To compute the duty cycle percentage, use two counters. Because the period of a cycle is H counter + L counter, you can measure two of these counters and compute the third.

You cannot measure a 0 width pulse.

Block Parameters

Counter

From the list, select a counter, 0 or 1.

Trigger mode

From the list, select the gating mode to use:

Mode	Description
Width of Gate High	Returns the number of 80 MHz cycles that occur when a single cycle of the input is high.
Width of Gate Low	Returns the number of 80 MHz cycles that occur when a single cycle of the input is low.
Between Rising Edges	Returns the number of 80 MHz cycles that occur between rising edges of the input signal. This cycle is the full period of the input signal.
Between Falling Edges	Returns the number of 80 MHz cycles that occur between falling edges of the input signal. This cycle is the full period of the input signal.

If the input signal has both fast rise and fall edges, **Between Rising Edges** and **Between Falling Edges** return the same value. If the input is asymmetric, one of these options can give a better result than the other.

Filter

You can apply a digital debouncing filter to the input pins before processing.

From the list, select a filter value to ignore pulses that are shorter than the filter time. The block ignores pulses shorter than the chosen duration. The value of **None** indicates that the input is not filtered

- None
- Minimum pulse width 125 nanoseconds
- Minimum pulse width 6.25 microseconds
- Minimum pulse width 1.25 milliseconds

Sample time

Enter the base sample time or a multiple of the base sample time (- 1 means sample time is inherited).

PCI slot (-1:autosearch)

If only one board of this type is in the target computer, enter - 1 to locate the board.

If two or more boards of this type are in the target computer, enter the bus number and the PCI slot number of the board associated with this driver block. Use the format **[BusNumber,SlotNumber]**.

To determine the bus number and the PCI slot number, type:

```
tg = slrt;  
getPCIInfo(tg, 'installed')
```

External Websites

- www.ni.com

National Instruments PCI-6221/37

Support for PCI-6221/37 and PXI-6221/37 boards

Board

National Instruments PCI-6221/37, PXI-6221/37

General Description

The 6221/37 M-series boards are data acquisition I/O boards with up to 16 single-ended or 8 differential 16-bit analog inputs, two 16-bit analog outputs, 10 digital I/O lines, and two 32-bit counters.

The Simulink Real-Time block library supports the 6221/37 boards with these driver blocks:

- National Instruments PCI-6221/37 Analog Input
- National Instruments PCI-6221/37 Analog Output
- National Instruments PCI-6221/37 Digital Input
- National Instruments PCI-6221/37 Digital Output
- National Instruments PCI-6221/37 Incremental Encoder
- National Instruments PCI-6221/37 PFI Digital Input
- National Instruments PCI-6221/37 PFI Digital Output
- National Instruments PCI-6221/37 PWM Generate
- National Instruments PCI-6221/37 PWM Measure

Board Characteristics

Board name	PCI-6221/37, PXI-6221/37
Manufacturer	National Instruments
Bus type	PCI, PXI (both use PCI version of blocks)

Multiple block instance support
Multiple board support

A/D: No, D/A: No, Digital I/O: Yes
Yes

External Websites

- www.ni.com

National Instruments PCI-6221/37 Analog Input

Analog Input block for PCI-6221/37 and PXI-6221/37 boards

Library

Simulink Real-Time Library for National Instruments

Scaling of Input to Output

I/O Module Input	Block Output Data Type	Scaling
Volts	Double	1

Block Parameters

Channel vector

Enter numbers from 1 through 16. This driver allows you to enter channel numbers in arbitrary order.

For example, to use the first, second, and fifth channels, enter

```
[1,2,5]
```

Number the lines beginning with 1 even if this board manufacturer starts numbering the lines with 0.

Range vector

Enter a range code for each of the channels in the channel vector. You can specify one value to replicate over the channel vector, or specify one for each channel. This driver allows each channel to be different. This board works only in bipolar mode.

The following table is a list of the ranges for this driver and the corresponding range codes.

Input Range (V)	Range Code
-10 to +10	10
-5 to +5	5
-1 to +1	1
-0.2 to +0.2	0.2

For example, if the first channel is -10 volts to +10 volts and the second and fifth channels are -1 volts to +1 volts, enter

[10, 1, 1]

Input coupling vector

Enter a coupling code for each of the channels in the channel vector. You can replicate one value over the channel vector, or specify one for each channel. This driver allows a different coupling for each channel.

The following table is a list of the couplings for this driver and the corresponding coupling codes.

Coupling	Coupling Code	Description
RSE	0	Analog input line connected to the positive input of the PGIA. Analog input ground (AIGND) internally connected to the negative input of the PGIA. See the National Instruments user manual.
NRSE	1	Analog input line connected to the positive input of the PGIA. Analog input sense (AISENSE) connected to the negative input of the PGIA. See the National Instruments user manual.
DIFF	2	First analog input line connected to the positive input of the PGIA. Second analog input line connected to the negative input of the PGIA. See the National Instruments user manual.

For example, if the first and second channels are single input and the fifth channel is a differential input, enter

[0, 0, 2]

National Instruments boards use a zero-based number scheme for differential mode channel pairs. Simulink Real-Time drivers use a one-based number scheme that adds a 1 to the I/O module number, as shown in the following table:

Zero-Based Channel Number		One-Based Channel Number	
+	-	+	-
0	8	1	9
1	9	2	10
2	10	3	11
3	11	4	12
4	12	5	13
5	13	6	14
6	14	7	15
7	15	8	16

The I/O module uses a second input 8 channels higher than the first channel as the negative input of the pair. In the example above, the I/O module would use the 13th channel as a differential input with the fifth channel.

If the board is set up for differential mode, you can read the data from either of the channels in the differential pair. For example, if you have a differential pair of 1 and 9, you can read the data from channel 1 or channel 9. However, you might want to read the lower channel number of the pair because it remains unchanged when you switch the input mode between single-ended and differential.

Scan interval

If **Channel vector** has more than one channel in it, enter the time between sampling different channels. Because execution waits for data to be available, this value increases the time to execute the block. If you enter a shorter time, you get the minimum of 4e-6, which is the fastest this board can acquire data. If you enter a time smaller than this value, the time will still be 4e-6. See the National Instruments user manual for a discussion about settling time and the need to control the time between sampling different channels depending on the impedance of the signal source.

Sample time

Enter the base sample time or a multiple of the base sample time (- 1 means sample time is inherited).

PCI slot (-1:autosearch)

If only one board of this type is in the target computer, enter -1 to locate the board.

If two or more boards of this type are in the target computer, enter the bus number and the PCI slot number of the board associated with this driver block. Use the format [**BusNumber,SlotNumber**].

To determine the bus number and the PCI slot number, type:

```
tg = slrt;  
getPCIInfo(tg, 'installed')
```

External Websites

- www.ni.com

National Instruments PCI-6221/37 Analog Output

Analog Output block for PCI-6221/37 and PXI-6221/37 boards

Library

Simulink Real-Time Library for National Instruments

Scaling of Output to Input

I/O Module Output	Block Input Data Type	Scaling
Volts	Double	1

Block Parameters

Channel vector

Enter 1 or 2. This driver allows the selection of individual D/A channels in arbitrary order. The number of elements defines the number of D/A channels used. For example, to use both of the analog output channels, enter

[1,2]

Number the channels beginning with 1 even if this board manufacturer starts numbering the channels with 0.

Reset vector

The reset vector controls the behavior of the channel at model termination. Enter a scalar or a vector that is the same length as the channel vector. If you specify a scalar value, that setting is replicated over the channel vector. If you specify a value of 1, the corresponding channel is reset to the value specified in the initial value vector. If you specify a value of 0, the channel remains at the last value attained while the model was running.

Initial value vector

The initial value vector contains the initial voltage values for the output channels. Enter a scalar or a vector that is the same length as the channel vector. If you specify

a scalar value, that value is replicated as the initial value over the channel vector. The channels are set to the initial values between the time the model is downloaded and the time it is started.

Sample time

Enter the base sample time or a multiple of the base sample time (- 1 means sample time is inherited).

PCI slot (-1:autosearch)

If only one board of this type is in the target computer, enter - 1 to locate the board.

If two or more boards of this type are in the target computer, enter the bus number and the PCI slot number of the board associated with this driver block. Use the format **[BusNumber,SlotNumber]**.

To determine the bus number and the PCI slot number, type:

```
tg = slrt;  
getPCIInfo(tg, 'installed')
```

External Websites

- www.ni.com

National Instruments PCI-6221/37 Digital Input

Digital Input block for PCI-6221/37 and PXI-6221/37 boards

Library

Simulink Real-Time Library for National Instruments

Note

Models can have multiple digital input blocks for one physical board. In this case, the Simulink Real-Time environment executes the blocks based on their sorted order as determined by the Simulink software.

Each board has one set of static digital I/O ports. You can independently configure each port to be input or output.

If a digital input block shares channels with a digital output block, the input block reads the last value written to the digital output block on the overlapping channels.

Scaling of Input to Output

I/O Module Input	Block Output Data Type	Scaling
TTL	Double	TTL low ≥ 0.0 TTL high = 1.0

Block Parameters

Channel vector

Enter numbers 1 or 2 to select the digital input lines used with this port. This driver allows the selection of individual digital input lines in arbitrary order. The number of elements defines the number of digital lines used.

For example, to use both digital inputs for one port, enter

[1,2]

Number the lines beginning with 1 even if this board manufacturer starts numbering the lines with 0.

Sample time

Enter the base sample time or a multiple of the base sample time (- 1 means sample time is inherited).

PCI slot (-1:autosearch)

If only one board of this type is in the target computer, enter - 1 to locate the board.

If two or more boards of this type are in the target computer, enter the bus number and the PCI slot number of the board associated with this driver block. Use the format **[BusNumber,SlotNumber]**.

To determine the bus number and the PCI slot number, type:

```
tg = slrt;  
getPCIInfo(tg, 'installed')
```

External Websites

- www.ni.com

National Instruments PCI-6221/37 Digital Output

Digital Output block for PCI-6221/37 and PXI-6221/37 boards

Library

Simulink Real-Time Library for National Instruments

Note

Models can have multiple digital output blocks for one physical board. In this case, the Simulink Real-Time environment executes the blocks based on their sorted order as determined by the Simulink software.

Each board has one set of digital I/O ports. You can independently configure each port to be input or output.

If a digital input block shares channels with a digital output block, the input block reads the last value written to the digital output block on the overlapping channels.

The block compares the value written to each port with 0.5.

Value written	Block writes digital output with a value of...
≥ 0.5	1
< 0.5	0

Scaling of Output to Input

I/O Module Output	Block Input Data Type	Scaling
TTL	Double	< 0.5 = TTL low ≥ 0.5 = TTL high

Block Parameters

Channel vector

Enter numbers 1 or 2 to select the digital output lines used with this port. This driver allows the selection of individual digital output lines in arbitrary order. The number of elements defines the number of digital lines used.

For example, to use the first output, enter

```
[1]
```

Number the lines beginning with 1 even if this board manufacturer starts numbering the lines with 0.

Reset vector

The reset vector controls the behavior of the channel at model termination. Enter a scalar or a vector that is the same length as the channel vector. If you specify a scalar value, that setting is replicated over the channel vector. If you specify a value of 1, the corresponding channel is reset to the value specified in the initial value vector. If you specify a value of 0, the channel remains at the last value attained while the model was running.

Initial value vector

The initial value vector contains the initial values (0 or 1) of the output channels. Enter a scalar or a vector that is the same length as the channel vector. If you enter a scalar, that value is replicated as the initial value over the channel vector. The channels are set to these initial values between the time the model is downloaded and the time it is started.

Sample time

Enter the base sample time or a multiple of the base sample time (- 1 means sample time is inherited).

PCI slot (-1:autosearch)

If only one board of this type is in the target computer, enter - 1 to locate the board.

If two or more boards of this type are in the target computer, enter the bus number and the PCI slot number of the board associated with this driver block. Use the format [**BusNumber**,**SlotNumber**].

To determine the bus number and the PCI slot number, type:

```
tg = slrt;  
getPCIInfo(tg, 'installed')
```

External Websites

- www.ni.com

National Instruments PCI-6221/37 Incremental Encoder

Incremental Encoder block for PCI-6221/37 and PXI-6221/37 boards

Library

Simulink Real-Time Library for National Instruments

Scaling Input to Output

I/O Module Input	Block Output Data Type	Scaling
TTL level quadrature encoder signals	Double	counts

Block Parameters

Channel

From the list, choose 0 or 1 for the channel counter you want to use. For information on input for these counters, see the National Instruments M Series user manual. The pin associations are:

Counter	Channel 0	Channel 1
A	PFI 0 (Pin 13)	PFI 3 (Pin 15)
B	PFI 2 (Pin 33)	PFI 5 (Pin 35)
Z	PFI 1 (Pin 32)	PFI 4 (Pin 34)

Counting mode

From the list, select a counting mode:

Mode	Description
Quadrature Mode x1	Count on rising edges of the A signal

Mode	Description
Quadrature Mode x2	Count on both rising and falling edges of the A signal
Quadrature Mode x4	Count on both rising and falling edges of both A and B signals

The level of the opposite signal when an edge occurs determines the count direction. For example, a rising edge of A when B is high counts one way, while an edge of A when B is low counts the other. For more information, see the National Instruments M Series user manual.

Initial count

The initial count specifies the initial value for the counter. The block resets the count to this value under the following conditions:

- When the model starts
- When the following is true, which typically occurs once per revolution for a rotary encoder.
 - **Reload at index pulse** check box is selected
 - Index pulse (Z input) is true
 - The phases of A and B match the setting of **Index phase**

Reload at index pulse

Select this check box to reset the counter to the value of **Initial count** at each index pulse. The reset occurs when:

- The encoder outputs a high level on its index output
- The phases of A and B match the setting of **Index phase**

Index phase

If you have selected the **Reload at index pulse** check box, the **Index phase** parameter specifies the phase of the quadrature signals during which the count reloads with **Initial count**. Your choice of value primarily depends on the particular incremental encoder you use. From the list, select one:

- A low B low
- A low B high
- A high B low

- A high B high

To choose an **Index phase** value for reset, use an oscilloscope, triggered on the index pulse, to observe the states of counters A and B. If your choice does not meet the encoder requirements, resets may be inconsistent.

Filter

You can apply a digital debouncing filter to the input pins before processing.

From the list, select a filter value to ignore pulses that are shorter than the filter time. The value of **None** indicates that the input is not filtered.

- None
- Minimum pulse width 125 nanoseconds
- Minimum pulse width 6.25 microseconds
- Minimum pulse width 1.25 milliseconds

Sample time

Enter the base sample time or a multiple of the base sample time (-1 means sample time is inherited).

PCI slot (-1:autosearch)

If only one board of this type is in the target computer, enter -1 to locate the board.

If two or more boards of this type are in the target computer, enter the bus number and the PCI slot number of the board associated with this driver block. Use the format [**BusNumber,SlotNumber**].

To determine the bus number and the PCI slot number, type:

```
tg = slrt;  
getPCIInfo(tg, 'installed')
```

External Websites

- www.ni.com

National Instruments PCI-6221/37 PFI Digital Input

PFI Digital Input block for PCI-6221/37 and PXI-6221/37 boards

Library

Simulink Real-Time Library for National Instruments

Description

A model can have more than one PFI digital input block for a given physical board. If a model has more than one digital input block, it executes the blocks in the order that the Simulink software has determined.

The two counters and the PFI digital input and output blocks share the 8 PFI digital I/O lines. Follow these rules when using these blocks:

You can read a PFI bit with this digital input block when...	You cannot read a PFI bit with this digital input block when...
PWM measure block is using the bit	PWM generate block is using the bit
Incremental encoder block is using the bit	PFI digital output block is using the bit

Scaling of Input to Output

I/O Module Input	Block Output Data Type	Scaling
TTL	Double	TTL low ≥ 0.0 TTL high = 1.0

Block Parameters

PFI bit vector (0-7)

This block uses 0 based numbering to reflect the names of the bits described in the National Instruments M Series user manual.

Enter a vector that contains the bits you want to monitor. For example, to read bits PFI 0, PFI 5, and PFI 7, enter

```
[0, 5, 7]
```

Sample time

Enter the base sample time or a multiple of the base sample time (- 1 means sample time is inherited).

PCI slot (-1:autosearch)

If only one board of this type is in the target computer, enter - 1 to locate the board.

If two or more boards of this type are in the target computer, enter the bus number and the PCI slot number of the board associated with this driver block. Use the format **[BusNumber, SlotNumber]**.

To determine the bus number and the PCI slot number, type:

```
tg = slrt;  
getPCIInfo(tg, 'installed')
```

External Websites

- www.ni.com

National Instruments PCI-6221/37 PFI Digital Output

PFI Digital Output block for PCI-6221/37 and PXI-6221/37 boards

Library

Simulink Real-Time Library for National Instruments

Description

A model can have more than one PFI digital input block for a given physical board. If a model has more than one digital input block, it executes the blocks in the order that the Simulink software has determined.

The two counters and the PFI digital input and output blocks share the 8 PFI digital I/O lines. Follow these rules when using these blocks:

- Do not use a PFI bit as a digital output when the PDF digital input block is using the bit.
- Do not use a PFI bit as a digital output when the incremental encoder is using the bit.
- Do not use a PFI bit for digital output when the PWM generate block is using the bit.

Scaling of Output to Input

I/O Module Output	Block Input Data Type	Scaling
TTL	Double	$< 0.5 = \text{TTL low}$ $\geq 0.5 = \text{TTL high}$

Block Parameters

PFI bit vector (0-7)

This block uses 0 based numbering to reflect the names of the bits described in the National Instruments M Series user manual.

Enter a vector that contains the bits you want to control. For example, to write bits PFI 1, PFI 3, and PFI 7, enter

```
[1, 3, 7]
```

Reset vector

The reset vector controls the behavior of the channel at model termination. Enter a scalar or a vector that is the same length as the channel vector. If you specify a scalar value, that setting is replicated over the channel vector. If you specify a value of 1, the corresponding channel is reset to the value specified in the initial value vector. If you specify a value of 0, the channel remains at the last value attained while the model was running.

Initial value vector

The initial value vector contains the initial values (0 or 1) of the block outputs. Enter a scalar or a vector of values, one for each output. If you enter a scalar, the driver replicates that value over the output vector.

The block applies this value as follows:

- The model uses this value when you first download the model to the target computer.
- If you set **Reset vector** to 1, the block output is reset to this value when model execution stops. If the value is greater than 0.5, the block sets output to **HIGH**. If the value is less than or equal to 0.5, the block sets the output to **LOW**.

Sample time

Enter the base sample time or a multiple of the base sample time (-1 means sample time is inherited).

PCI slot (-1:autosearch)

If only one board of this type is in the target computer, enter -1 to locate the board.

If two or more boards of this type are in the target computer, enter the bus number and the PCI slot number of the board associated with this driver block. Use the format [**BusNumber**, **SlotNumber**].

To determine the bus number and the PCI slot number, type:

```
tg = slrt;  
getPCIInfo(tg, 'installed')
```

External Websites

- www.ni.com

National Instruments PCI-6221/37 PWM Generate

PWM Generate block for PCI-6221/37 and PXI-6221/37 boards

Library

Simulink Real-Time Library for National Instruments

Description

Use this block to generate variable frequency and pulse width output.

The M Series boards have two 32-bit counters that you can use to generate pulse trains. Inputs are in counts of the 80 MHz reference frequency on the onboard clock.

- H input is the number of counts that the output is high.
- L input is the number of counts that the output is low.

If the H input goes to 0, the output stays low. If the L input goes to 0, the output stays high. If both are 0, the output goes low.

Block Parameters

Counter

From the list, select the counter, 0 or 1, that you want to use. The output for these counters is on the following pins:

Counter	Pin
0	PFI 6 (Pin 17)
1	PFI 7 (Pin 36)

Initial high count

Enter the number of counts the output is high between the time the Simulink engine calls the `mdlStart` routine for this block and the first time it calls `mdlOutputs`. This

length of time depends on the number of blocks in the model and the sorted order as determined by the Simulink software.

If you enter a value of 0, the output stays low until the first time the Simulink engine calls `mdlOutputs`.

Initial low count

Enter the number of counts the output is low between the time the Simulink engine calls the `mdlStart` routine for this block and the first time it calls `mdlOutputs`. This length of time depends on the number of blocks in the model and the sorted order as determined by the Simulink software. If you enter a value of 0, the output stays high until the first time the Simulink engine calls `mdlOutputs`, unless you have also set `H` to 0.

Arm input

Select this check box to add a third input port to the block.

- If the input connected to this port is greater than 0.5, the block arms the counter. Output then occurs.
- If the input connected to this port is less than or equal to 0.5, the block disarms the counter and the output goes to the level of the value in the **Disarm level** parameter.

Disarm level

From the list, select the disarm level **Disarm to LOW** or **Disarm to HIGH**. If the model disarms the block and the level of the value is **Arm input**, the output goes to the level you select here.

Stop level

From the list, select the stop level **Stop to LOW** or **Stop to HIGH**. When model execution stops, the output goes to the level you choose here.

Sample time

Enter the base sample time or a multiple of the base sample time (-1 means sample time is inherited).

PCI slot (-1:autosearch)

If only one board of this type is in the target computer, enter -1 to locate the board.

If two or more boards of this type are in the target computer, enter the bus number and the PCI slot number of the board associated with this driver block. Use the format **[BusNumber, SlotNumber]**.

To determine the bus number and the PCI slot number, type:

```
tg = slrt;  
getPCIInfo(tg, 'installed')
```

External Websites

- www.ni.com

National Instruments PCI-6221/37 PWM Measure

PWM Measure block for PCI-6221/37 and PXI-6221/37 boards

Library

Simulink Real-Time Library for National Instruments

Description

Use this block to measure the pulse width or the period of a signal.

To measure the pulse width of a signal, connect the signal to the gate, as follows:

Counter	Gate Pin
0	PFI 1 (Pin 32)
1	PFI 4 (Pin 34)

The input waveform must have fast rise and fall times and conform to TTL signal levels of [0,5] volts. Use external signal conditioning to achieve these levels. If you input a sine wave, the decision points are less definite and the measurement is noisy. In extreme cases, the gate can transition multiple times during a slow signal transition.

This block does not queue or buffer measurements. If the gate changes state, the driver holds the current count, overwriting the previous value.

This block returns the length of the last gate period before the block executes.

To compute the duty cycle percentage, use two counters. Because the period of a cycle is H counter + L counter, you can measure two of these counters and compute the third.

You cannot measure a 0 width pulse.

Block Parameters

Counter

From the list, select a counter, 0 or 1.

Trigger mode

From the list, select the gating mode to use:

Mode	Description
Width of Gate High	Returns the number of 80 MHz cycles that occur when a single cycle of the input is high.
Width of Gate Low	Returns the number of 80 MHz cycles that occur when a single cycle of the input is low.
Between Rising Edges	Returns the number of 80 MHz cycles that occur between rising edges of the input signal. This cycle is the full period of the input signal.
Between Falling Edges	Returns the number of 80 MHz cycles that occur between falling edges of the input signal. This cycle is the full period of the input signal.

If the input signal has both fast rise and fall edges, **Between Rising Edges** and **Between Falling Edges** return the same value. If the input is asymmetric, one of these options can give a better result than the other.

Filter

You can apply a digital debouncing filter to the input pins before processing.

From the list, select a filter value to ignore pulses that are shorter than the filter time. The block ignores pulses shorter than the chosen duration. The value of **None** indicates that the input is not filtered

- None
- Minimum pulse width 125 nanoseconds
- Minimum pulse width 6.25 microseconds
- Minimum pulse width 1.25 milliseconds

Sample time

Enter the base sample time or a multiple of the base sample time (- 1 means sample time is inherited).

PCI slot (-1:autosearch)

If only one board of this type is in the target computer, enter - 1 to locate the board.

If two or more boards of this type are in the target computer, enter the bus number and the PCI slot number of the board associated with this driver block. Use the format **[BusNumber,SlotNumber]**.

To determine the bus number and the PCI slot number, type:

```
tg = slrt;  
getPCIInfo(tg, 'installed')
```

External Websites

- www.ni.com

National Instruments PCI-6225

Support for PCI-6225 and PXI-6225 boards

Board

National Instruments PCI-6225, PXI-6225

General Description

The 6225 M-series boards are data acquisition I/O boards with two 16-bit analog outputs, 24 digital I/O lines, and two 32-bit counters.

The Simulink Real-Time block library supports the 6225 boards with these driver blocks:

- National Instruments PCI-6225 Analog Input
- National Instruments PCI-6225 Analog Output
- National Instruments PCI-6225 Digital Input
- National Instruments PCI-6225 Digital Output
- National Instruments PCI-6225 Incremental Encoder
- National Instruments PCI-6225 PFI Digital Input
- National Instruments PCI-6225 PFI Digital Output
- National Instruments PCI-6225 PWM Generate
- National Instruments PCI-6225 PWM Measure

Board Characteristics

Board name	PCI-6225, PXI-6225
Manufacturer	National Instruments
Bus type	PCI, PXI (both use PCI version of blocks)

Multiple block instance support

- A/D
One block per board
- D/A
One block per board
- Digital I/O
Multiple blocks per board
- Incremental Encoder
One block per counter per board
- PFI Digital Input/Output
Multiple blocks per board
- PWM Generate and Measure
One block per counter per board

Multiple board support

Yes

External Websites

- www.ni.com

National Instruments PCI-6225 Analog Input

Analog Input block for PCI-6225 and PXI-6225 boards

Library

Simulink Real-Time Library for National Instruments

Scaling of Input to Output

I/O Module Input	Block Output Data Type	Scaling
Volts	Double	1

Block Parameters

Channel vector

Enter numbers between 1 and 80. This driver allows you to enter channel numbers in arbitrary order.

For example, to use the first, second, and fifth channels, enter

```
[1,2,5]
```

Number the lines beginning with 1 even if this board manufacturer starts numbering the lines with 0.

Range vector

Enter a range code for each of the channels in the channel vector. You can specify one value to replicate over the channel vector, or specify one for each channel. This driver allows each channel to be different. This board works only in bipolar mode.

The following table is a list of the ranges for this driver and the corresponding range codes.

Input Range (V)	Range Code
-10 to +10	10

Input Range (V)	Range Code
-5 to +5	5
-1 to +1	1
-0.2 to +0.2	0.2

For example, if the first channel is -10 to +10 volts and the second and fifth channels are -1 to +1 volts, enter

[10,1,1]

Input coupling vector

Enter a coupling code for each of the channels in the channel vector. You can replicate one value over the channel vector, or specify one for each channel. This driver allows a different coupling for each channel.

The following table is a list of the couplings for this driver and the corresponding coupling codes.

Coupling	Coupling Code	Description
RSE	0	Analog input line connected to the positive input of the PGIA. Analog input ground (AIGND) internally connected to the negative input of the PGIA. See the National Instruments user manual.
NRSE	1	Analog input line connected to the positive input of the PGIA. Analog input sense (AISENSE) connected to the negative input of the PGIA. See the National Instruments user manual.
DIFF	2	First analog input line connected to the positive input of the PGIA. Second analog input line connected to the negative input of the PGIA. See the National Instruments user manual.

For example, if the first and second channels are single input and the fifth channel is a differential input, enter

[0,0,2]

National Instruments boards use a zero-based number scheme for differential mode channel pairs. Simulink Real-Time drivers use a one-based number scheme that adds a 1 to the I/O module number, as shown in the following table:

Zero-Based Channel Number		One-Based Channel Number	
+	-	+	-
0–7	8–15	1–8	9–16
16–23	24–31	17–24	25–32
32–39	40–47	33–40	41–48
48–55	56–63	49–56	57–64
64–71	72–79	65–72	73–80

The I/O module uses a second input 8 channels higher than the first channel as the negative input of the pair. In the example above, the module would use channel 13 as a differential input with the fifth channel.

If the board is set up for differential mode, you can read the data from either of the channels in the differential pair. For example, if you have a differential pair of 1 and 9, you can read the data from channel 1 or channel 9. However, you might want to read the lower channel number of the pair because it remains unchanged when you switch the input mode between single-ended and differential.

Scan interval

If **Channel vector** has more than one channel in it, enter the time between sampling different channels. Because execution waits for data to be available, this value increases the time to execute the block. If you enter a shorter time, you get the minimum of 4e-6. If you enter a time smaller than this value, the time will still be 4e-6, which is the fastest that this board can acquire data.

See the National Instruments user manual for a discussion about settling time and the need to control the time between sampling different channels depending on the impedance of the signal source. To attain equilibrium, the setting of this time is more important with a higher gain.

Sample time

Enter the base sample time or a multiple of the base sample time (-1 means sample time is inherited).

PCI slot (-1:autosearch)

If only one board of this type is in the target computer, enter -1 to locate the board.

If two or more boards of this type are in the target computer, enter the bus number and the PCI slot number of the board associated with this driver block. Use the format **[BusNumber, SlotNumber]**.

To determine the bus number and the PCI slot number, type:

```
tg = slrt;  
getPCIInfo(tg, 'installed')
```

External Websites

- www.ni.com

National Instruments PCI-6225 Analog Output

Analog Output block for PCI-6225 and PXI-6225 boards

Library

Simulink Real-Time Library for National Instruments

Scaling of Output to Input

I/O Module Output	Block Input Data Type	Scaling
Volts	Double	1

Block Parameters

Channel vector

Enter 1 to 2,. This driver allows the selection of individual D/A channels in arbitrary order. The number of elements defines the number of D/A channels used. For example, to use both of the analog output channels, enter

```
[1,2]
```

Number the channels begin with 1 even if this board manufacturer starts numbering the channels with 0.

Reset vector

The reset vector controls the behavior of the channel at model termination. Enter a scalar or a vector that is the same length as the channel vector. If you specify a scalar value, that setting is replicated over the channel vector. If you specify a value of 1, the corresponding channel is reset to the value specified in the initial value vector. If you specify a value of 0, the channel remains at the last value attained while the model was running.

Initial value vector

The initial value vector contains the initial voltage values for the output channels. Enter a scalar or a vector that is the same length as the channel vector. If you specify

a scalar value, that value is replicated as the initial value over the channel vector. The channels are set to the initial values between the time the model is downloaded and the time it is started.

Sample time

Enter the base sample time or a multiple of the base sample time (- 1 means sample time is inherited).

PCI slot (-1:autosearch)

If only one board of this type is in the target computer, enter - 1 to locate the board.

If two or more boards of this type are in the target computer, enter the bus number and the PCI slot number of the board associated with this driver block. Use the format **[BusNumber,SlotNumber]**.

To determine the bus number and the PCI slot number, type:

```
tg = slrt;  
getPCIInfo(tg, 'installed')
```

External Websites

- www.ni.com

National Instruments PCI-6225 Digital Input

Digital Input block for PCI-6225 and PXI-6225 boards

Library

Simulink Real-Time Library for National Instruments

Note

Models can have multiple digital input blocks for one physical board. In this case, the Simulink Real-Time environment executes the blocks based on their sorted order as determined by the Simulink software.

Each board has one set of static digital I/O ports. You can independently configure each port to be input or output.

If a digital input block shares channels with a digital output block, the input block reads the last value written to the digital output block on the overlapping channels.

Scaling of Input to Output

I/O Module Input	Block Output Data Type	Scaling
TTL	Double	TTL low ≥ 0.0 TTL high = 1.0

Block Parameters

Channel vector

Enter numbers between 1 and 8 to select the digital input lines used with this port. This driver allows the selection of individual digital input lines in arbitrary order. The number of elements defines the number of digital lines used.

For example, to use the first eight of the digital inputs for one port, enter

[1,2,3,4,5,6,7,8]

Number the lines beginning with 1 even if this board manufacturer starts numbering the lines with 0.

Sample time

Enter the base sample time or a multiple of the base sample time (- 1 means sample time is inherited).

PCI slot (-1:autosearch)

If only one board of this type is in the target computer, enter - 1 to locate the board.

If two or more boards of this type are in the target computer, enter the bus number and the PCI slot number of the board associated with this driver block. Use the format **[BusNumber,SlotNumber]**.

To determine the bus number and the PCI slot number, type:

```
tg = slrt;  
getPCIInfo(tg, 'installed')
```

External Websites

- www.ni.com

National Instruments PCI-6225 Digital Output

Digital Output block for PCI-6225 and PXI-6225 boards

Library

Simulink Real-Time Library for National Instruments

Note

Models can have multiple digital output blocks for one physical board. In this case, the Simulink Real-Time environment executes the blocks based on their sorted order as determined by the Simulink software.

Each board has one set of static digital I/O ports. You can independently set each port to be input or output.

If a digital input block shares channels with a digital output block, the input block reads the last value written to the digital output block on the overlapping channels.

The block compares the value written to each port with 0.5.

Value written	Block writes digital output with a value of...
≥ 0.5	1
< 0.5	0

Scaling of Output to Input

I/O Module Output	Block Input Data Type	Scaling
TTL	Double	$< 0.5 = \text{TTL low}$ $\geq 0.5 = \text{TTL high}$

Block Parameters

Channel vector

Enter numbers between 1 and 8 to select the digital output lines used with this port. This driver allows the selection of individual digital output lines in arbitrary order. The number of elements defines the number of digital lines used.

For example, to use the first eight digital outputs for, enter

```
[1,2,3,4,5,6,7,8]
```

Number the lines beginning with 1 even if this board manufacturer starts numbering the lines with 0.

Reset vector

The reset vector controls the behavior of the channel at model termination. Enter a scalar or a vector that is the same length as the channel vector. If you specify a scalar value, that setting is replicated over the channel vector. If you specify a value of 1, the corresponding channel is reset to the value specified in the initial value vector. If you specify a value of 0, the channel remains at the last value attained while the model was running.

Initial value vector

The initial value vector contains the initial values (0 or 1) of the output channels. Enter a scalar or a vector that is the same length as the channel vector. If you enter a scalar, that value is replicated as the initial value over the channel vector. The channels are set to these initial values between the time the model is downloaded and the time it is started.

Sample time

Enter the base sample time or a multiple of the base sample time (- 1 means sample time is inherited).

PCI slot (-1:autosearch)

If only one board of this type is in the target computer, enter - 1 to locate the board.

If two or more boards of this type are in the target computer, enter the bus number and the PCI slot number of the board associated with this driver block. Use the format **[BusNumber,SlotNumber]**.

To determine the bus number and the PCI slot number, type:

```
tg = slrt;  
getPCIInfo(tg, 'installed')
```

External Websites

- www.ni.com

National Instruments PCI-6225 Incremental Encoder

Incremental Encoder block for PCI-6225 and PXI-6225 boards

Library

Simulink Real-Time Library for National Instruments

Scaling Input to Output

I/O Module Input	Block Output Data Type	Scaling
TTL level quadrature encoder signals	Double	counts

Block Parameters

Channel

From the list, choose 0 or 1 for the channel counter you want to use. For information on input for these counters, see the National Instruments M Series user manual. The pin associations are:

Counter	Channel 0	Channel 1
A	PFI 8 (Pin 37)	PFI 3 (Pin 42)
B	PFI 10 (Pin 45)	PFI 11 (Pin 46)
Z	PFI 9 (Pin 3)	PFI 4 (Pin 41)

Counting mode

From the list, select a counting mode:

Mode	Description
Quadrature Mode x1	Count on rising edges of the A signal
Quadrature Mode x2	Count on both rising and falling edges of the A signal

Mode	Description
Quadrature Mode x4	Count on both rising and falling edges of both A and B signals

The level of the opposite signal when an edge occurs determines the count direction. For example, a rising edge of A when B is high counts one way, while an edge of A when B is low counts the other. For more information, see the National Instruments M Series user manual.

Initial count

The initial count specifies the initial value for the counter. The block resets the count to this value under the following conditions:

- When the model starts
- When the following is true, which typically occurs once per revolution for a rotary encoder.
 - **Reload at index pulse** check box is selected
 - Index pulse (Z input) is true
 - The phases of A and B match the setting of **Index phase**

Reload at index pulse

Select this check box to reset the counter to the value of **Initial count** at each index pulse. The reset occurs when:

- The encoder outputs a high level on its index output
- The phases of A and B match the setting of **Index phase**

Index phase

If you have selected the **Reload at index pulse** check box, the **Index phase** parameter specifies the phase of the quadrature signals during which the count reloads with **Initial count**. Your choice of value primarily depends on the particular incremental encoder you use. From the list, select one:

- A low B low
- A low B high
- A high B low
- A high B high

To choose an **Index phase** for reset, use an oscilloscope, triggered on the index pulse, to observe the states of counters A and B. If your choice does not meet the encoder requirements, resets may be inconsistent.

Filter

You can apply a digital debouncing filter to the input pins before processing.

From the list, select a filter value to ignore pulses that are shorter than the filter time. The value of **NONE** indicates that the input is not filtered.

- None
- Minimum pulse width 125 nanoseconds
- Minimum pulse width 6.25 microseconds
- Minimum pulse width 1.25 milliseconds

Sample time

Enter the base sample time or a multiple of the base sample time (- 1 means sample time is inherited).

PCI slot (-1:autosearch)

If only one board of this type is in the target computer, enter - 1 to locate the board.

If two or more boards of this type are in the target computer, enter the bus number and the PCI slot number of the board associated with this driver block. Use the format **[BusNumber, SlotNumber]**.

To determine the bus number and the PCI slot number, type:

```
tg = slrt;  
getPCIInfo(tg, 'installed')
```

External Websites

- www.ni.com

National Instruments PCI-6225 PFI Digital Input

PFI Digital Input block for PCI-6225 and PXI-6225 boards

Library

Simulink Real-Time Library for National Instruments

Description

A model can have more than one PFI digital input block for a given physical board. If a model has more than one digital input block, it executes the blocks in the order that the Simulink software has determined.

The two counters and the PFI digital input and output blocks share the 16 PFI digital I/O lines. Follow these rules when using these blocks:

You can read a PFI bit with this digital input block when...	You cannot read a PFI bit with this digital input block when...
PWM measure block is using the bit	PWM generate block is using the bit
Incremental encoder block is using the bit	PFI digital output block is using the bit

Scaling of Input to Output

I/O Module Input	Block Output Data Type	Scaling
TTL	Double	TTL low ≥ 0.0 TTL high = 1.0

Block Parameters

PFI bit vector (0-15)

This block uses 0 based numbering to reflect the names of the bits described in the National Instruments M Series user manual.

Enter a vector that contains the bits you want to monitor. For example, to read bits PFI 0, PFI 5, and PFI 7, enter

```
[0, 5, 7]
```

Sample time

Enter the base sample time or a multiple of the base sample time (- 1 means sample time is inherited).

PCI slot (-1:autosearch)

If only one board of this type is in the target computer, enter - 1 to locate the board.

If two or more boards of this type are in the target computer, enter the bus number and the PCI slot number of the board associated with this driver block. Use the format **[BusNumber, SlotNumber]**.

To determine the bus number and the PCI slot number, type:

```
tg = slrt;  
getPCIInfo(tg, 'installed')
```

External Websites

- www.ni.com

National Instruments PCI-6225 PFI Digital Output

PFI Digital Output block for PCI-6225 and PXI-6225 boards

Library

Simulink Real-Time Library for National Instruments

Description

A model can have more than one PFI digital input block for a given physical board. If a model has more than one digital input block, it executes the blocks in the order that the Simulink software has determined.

The two counters and the PFI digital input and output blocks share the 16 PFI digital I/O lines. Follow these rules when using these blocks:

- Do not use a PFI bit as a digital output when the PDF digital input block is using the bit.
- Do not use a PFI bit as a digital output when the incremental encoder is using the bit.
- Do not use a PFI bit for digital output when the PWM generate block is using the bit.

Scaling of Output to Input

I/O Module Output	Block Input Data Type	Scaling
TTL	Double	< 0.5 = TTL low ≥ 0.5 = TTL high

Block Parameters

PFI bit vector (0-15)

This block uses 0 based numbering to reflect the names of the bits described in the National Instruments M Series user manual.

Enter a vector that contains the bits you want to control. For example, to write bits PFI 1, PFI 3, and PFI 9, enter

```
[1, 3, 9]
```

Reset vector

The reset vector controls the behavior of the channel at model termination. Enter a scalar or a vector that is the same length as the channel vector. If you specify a scalar value, that setting is replicated over the channel vector. If you specify a value of 1, the corresponding channel is reset to the value specified in the initial value vector. If you specify a value of 0, the channel remains at the last value attained while the model was running.

Initial value vector

The initial value vector contains the initial values (0 or 1) of the block outputs. Enter a scalar or a vector of values, one for each output. If you enter a scalar, the driver replicates that value over the output vector.

The block applies this value as follows:

- The model uses this value when you first download the model to the target computer.
- If you set **Reset vector** to 1, the block output is reset to this value when model execution stops. If the value is greater than 0.5, the block sets output to **HIGH**. If the value is less than or equal to 0.5, the block sets the output to **LOW**.

Sample time

Enter the base sample time or a multiple of the base sample time (-1 means sample time is inherited).

PCI slot (-1:autosearch)

If only one board of this type is in the target computer, enter -1 to locate the board.

If two or more boards of this type are in the target computer, enter the bus number and the PCI slot number of the board associated with this driver block. Use the format [**BusNumber**, **SlotNumber**].

To determine the bus number and the PCI slot number, type:

```
tg = slrt;  
getPCIInfo(tg, 'installed')
```

External Websites

- www.ni.com

National Instruments PCI-6225 PWM Generate

PWM Generate block for PCI-6225 and PXI-6225 boards

Library

Simulink Real-Time Library for National Instruments

Description

Use this block to generate variable frequency and pulse width output.

The M Series boards have two 32-bit counters that you can use to generate pulse trains. Inputs are in counts of the 80 MHz reference frequency on the onboard clock.

- H input is the number of counts that the output is high.
- L input is the number of counts that the output is low.

If the H input goes to 0, the output stays low. If the L input goes to 0, the output stays high. If both are 0, the output goes low.

Block Parameters

Counter

From the list, select the counter, 0 or 1, that you want to use. The output for these counters is on the following pins:

Counter	Pin
0	PFI 12 (Pin 2)
1	PFI 13 (Pin 40)

Initial high count

Enter the number of counts the output is high between the time the Simulink engine calls the `mdlStart` routine for this block and the first time it calls `mdlOutputs`. This

length of time depends on the number of blocks in the model and the sorted order as determined by the Simulink software.

If you enter a value of 0, the output stays low until the first time the Simulink engine calls `mdlOutputs`.

Initial low count

Enter the number of counts the output is low between the time the Simulink engine calls the `mdlStart` routine for this block and the first time it calls `mdlOutputs`. This length of time depends on the number of blocks in the model and the sorted order as determined by the Simulink software. If you enter a value of 0, the output stays high until the first time the Simulink engine calls `mdlOutputs`, unless you have also set `H` to 0.

Arm input

Select this check box to add a third input port to the block.

- If the input connected to this port is greater than 0.5, the block arms the counter. Output then occurs.
- If the input connected to this port is less than or equal to 0.5, the block disarms the counter and the output goes to the level of the value in the **Disarm level** parameter.

Disarm level

From the list, select the disarm level **Disarm to LOW** or **Disarm to HIGH**. If the model disarms the block and the level of the value is **Arm input**, the output goes to the level you select here.

Stop level

From the list, select the stop level **Stop to LOW** or **Stop to HIGH**. When model execution stops, the output goes to the level you choose here.

Sample time

Enter the base sample time or a multiple of the base sample time (-1 means sample time is inherited).

PCI slot (-1:autosearch)

If only one board of this type is in the target computer, enter -1 to locate the board.

If two or more boards of this type are in the target computer, enter the bus number and the PCI slot number of the board associated with this driver block. Use the format **[BusNumber, SlotNumber]**.

To determine the bus number and the PCI slot number, type:

```
tg = slrt;  
getPCIInfo(tg, 'installed')
```

External Websites

- www.ni.com

National Instruments PCI-6225 PWM Measure

PWM Measure block for PCI-6225 and PXI-6225 boards

Library

Simulink Real-Time Library for National Instruments

Description

Use this block to measure the pulse width or the period of a signal.

To measure the pulse width of a signal, connect the signal to the gate, as follows:

Counter	Gate Pin
0	PFI 9 (Pin 3)
1	PFI 4 (Pin 41)

The input waveform must have fast rise and fall times and conform to TTL signal levels of [0,5] volts. Use external signal conditioning to achieve these levels. If you input a sine wave, the decision points are less definite and the measurement is noisy. In extreme cases, the gate can transition multiple times during a slow signal transition.

This block does not queue or buffer measurements. If the gate changes state, the driver holds the current count, overwriting the previous value.

This block returns the length of the last gate period before the block executes.

To compute the duty cycle percentage, use two counters. Because the period of a cycle is H counter + L counter, you can measure two of these counters and compute the third.

You cannot measure a 0 width pulse.

Block Parameters

Counter

From the list, select a counter, 0 or 1.

Trigger mode

From the list, select the gating mode to use:

Mode	Description
Width of Gate High	Returns the number of 80 MHz cycles that occur when a single cycle of the input is high.
Width of Gate Low	Returns the number of 80 MHz cycles that occur when a single cycle of the input is low.
Between Rising Edges	Returns the number of 80 MHz cycles that occur between rising edges of the input signal. This cycle is the full period of the input signal.
Between Falling Edges	Returns the number of 80 MHz cycles that occur between falling edges of the input signal. This cycle is the full period of the input signal.

If the input signal has both fast rise and fall edges, **Between Rising Edges** and **Between Falling Edges** return the same value. If the input is asymmetric, one of these options can give a better result than the other.

Filter

You can apply a digital debouncing filter to the input pins before processing.

From the list, select a filter value to ignore pulses that are shorter than the filter time. The block ignores pulses shorter than the chosen duration. The value of **None** indicates that the input is not filtered

- None
- Minimum pulse width 125 nanoseconds
- Minimum pulse width 6.25 microseconds
- Minimum pulse width 1.25 milliseconds

Sample time

Enter the base sample time or a multiple of the base sample time (- 1 means sample time is inherited).

PCI slot (-1:autosearch)

If only one board of this type is in the target computer, enter - 1 to locate the board.

If two or more boards of this type are in the target computer, enter the bus number and the PCI slot number of the board associated with this driver block. Use the format **[BusNumber,SlotNumber]**.

To determine the bus number and the PCI slot number, type:

```
tg = slrt;  
getPCIInfo(tg, 'installed')
```

External Websites

- www.ni.com

National Instruments PCI-6229

Support for PCI-6229 and PXI-6229 boards

Board

National Instruments PCI-6229, PXI-6229

General Description

The 6229 M-series boards are data acquisition I/O boards with 32 single-ended or 16 differential 16-bit analog inputs, four 16-bit analog outputs, 48 digital I/O lines, and two 32-bit counters.

The Simulink Real-Time block library supports the 6229 boards with these driver blocks:

- National Instruments PCI-6229 Analog Input
- National Instruments PCI-6229 Analog Output
- National Instruments PCI-6229 Digital Input
- National Instruments PCI-6229 Digital Output
- National Instruments PCI-6229 Incremental Encoder
- National Instruments PCI-6229 PFI Digital Input
- National Instruments PCI-6229 PFI Digital Output
- National Instruments PCI-6229 PWM Generate
- National Instruments PCI-6229 PWM Measure

Board Characteristics

Board name	PCI-6229, PXI-6229
Manufacturer	National Instruments
Bus type	PCI, PXI (both use PCI version of blocks)
Multiple block instance support	A/D: No, D/A: No, Digital I/O: Yes

Multiple board support

Yes

External Websites

- www.ni.com

National Instruments PCI-6229 Analog Input

Analog Input block for PCI-6229 and PXI-6229 boards

Library

Simulink Real-Time Library for National Instruments

Scaling of Input to Output

I/O Module Input	Block Output Data Type	Scaling
Volts	Double	1

Block Parameters

Channel vector

Enter numbers between 1 and 32. This driver allows you to enter channel numbers in arbitrary order.

For example, to use the first, second, and fifth channels, enter

```
[1,2,5]
```

Number the lines beginning with 1 even if this board manufacturer starts numbering the lines with 0.

Range vector

Enter a range code for each of the channels in the channel vector. You can specify one value to replicate over the channel vector, or specify one for each channel. This driver allows each channel to be different. This board works only in bipolar mode.

The following table is a list of the ranges for this driver and the corresponding range codes.

Input Range (V)	Range Code
-10 to +10	10

Input Range (V)	Range Code
-5 to +5	5
-1 to +1	1
-0.2 to +0.2	0.2

For example, if the first channel is -10 to +10 volts and the second and fifth channels are -1 to +1 volts, enter

[10, 1, 1]

Input coupling vector

Enter a coupling code for each of the channels in the channel vector. You can replicate one value over the channel vector, or specify one for each channel. This driver allows a different coupling for each channel.

The following table is a list of the couplings for this driver and the corresponding coupling codes.

Coupling	Coupling Code	Description
RSE	0	Analog input line connected to the positive input of the PGIA. Analog input ground (AIGND) internally connected to the negative input of the PGIA. See the National Instruments user manual.
NRSE	1	Analog input line connected to the positive input of the PGIA. Analog input sense (AISENSE) connected to the negative input of the PGIA. See the National Instruments user manual.
DIFF	2	First analog input line connected to the positive input of the PGIA. Second analog input line connected to the negative input of the PGIA. See the National Instruments user manual.

For example, if the first and second channels are single input and the fifth channel is a differential input, enter

[0, 0, 2]

National Instruments boards use a zero-based number scheme for differential mode channel pairs. Simulink Real-Time drivers use a one-based number scheme that adds a 1 to the I/O module number, as shown in the following table:

Zero-Based Channel Number		One-Based Channel Number	
+	-	+	-
0	8	1	9
1	9	2	10
2	10	3	11
3	11	4	12
4	12	5	13
5	13	6	14
6	14	7	15
7	15	8	16
16	24	17	25
17	25	18	26
18	26	19	27
19	27	20	28
20	28	21	29
21	29	22	30
22	30	23	31
23	31	24	32

The I/O module uses a second input 8 channels higher than the first channel as the negative input of the pair. In the example above, the module would use the 13 as a differential input with the fifth channel.

If the module is set up for differential mode, you can read the data from either of the channels in the differential pair. For example, if you have a differential pair of 1 and 9, you can read the data from channel 1 or channel 9. However, you might want to read the lower channel number of the pair because it remains unchanged when you switch the input mode between single-ended and differential.

Scan interval

If **Channel vector** has more than one channel in it, enter the time between sampling different channels. Because execution waits for data to be available, this value increases the time to execute the block. If you enter a shorter time, you get the minimum of 4e-6. If you enter a time smaller than this value, the time will still be

4e-6, which is the fastest this board can acquire data. See the National Instruments user manual for a discussion about settling time and the need to control the time between sampling different channels depending on the impedance of the signal source.

Sample time

Enter the base sample time or a multiple of the base sample time (- 1 means sample time is inherited).

PCI slot (-1:autosearch)

If only one board of this type is in the target computer, enter - 1 to locate the board.

If two or more boards of this type are in the target computer, enter the bus number and the PCI slot number of the board associated with this driver block. Use the format [**BusNumber,SlotNumber**].

To determine the bus number and the PCI slot number, type:

```
tg = slrt;  
getPCIInfo(tg, 'installed')
```

External Websites

- www.ni.com

National Instruments PCI-6229 Analog Output

Analog Output block for PCI-6229 and PXI-6229 boards

Library

Simulink Real-Time Library for National Instruments

Scaling of Output to Input

I/O Module Output	Block Input Data Type	Scaling
Volts	Double	1

Block Parameters

Channel vector

Enter 1 to 4. This driver allows the selection of individual D/A channels in arbitrary order. The number of elements defines the number of D/A channels used. For example, to use the four analog output channels, enter

```
[1, 2, 3, 4]
```

Number the channels begin with 1 even if this board manufacturer starts numbering the channels with 0.

Reset vector

The reset vector controls the behavior of the channel at model termination. Enter a scalar or a vector that is the same length as the channel vector. If you specify a scalar value, that setting is replicated over the channel vector. If you specify a value of 1, the corresponding channel is reset to the value specified in the initial value vector. If you specify a value of 0, the channel remains at the last value attained while the model was running.

Initial value vector

The initial value vector contains the initial voltage values for the output channels. Enter a scalar or a vector that is the same length as the channel vector. If you specify

a scalar value, that value is replicated as the initial value over the channel vector. The channels are set to the initial values between the time the model is downloaded and the time it is started.

Sample time

Enter the base sample time or a multiple of the base sample time (- 1 means sample time is inherited).

PCI slot (-1:autosearch)

If only one board of this type is in the target computer, enter - 1 to locate the board.

If two or more boards of this type are in the target computer, enter the bus number and the PCI slot number of the board associated with this driver block. Use the format **[BusNumber,SlotNumber]**.

To determine the bus number and the PCI slot number, type:

```
tg = slrt;  
getPCIInfo(tg, 'installed')
```

External Websites

- www.ni.com

National Instruments PCI-6229 Digital Input

Digital Input block for PCI-6229 and PXI-6229 boards

Library

Simulink Real-Time Library for National Instruments

Note

Models can have multiple digital input blocks for one physical board. In this case, the Simulink Real-Time environment executes the blocks based on their sorted order as determined by the Simulink software.

Each board has one set of static digital I/O ports. You can independently configure each port to be input or output.

If a digital input block shares channels with a digital output block, the input block reads the last value written to the digital output block on the overlapping channels.

Scaling of Input to Output

I/O Module Input	Block Output Data Type	Scaling
TTL	Double	TTL low ≥ 0.0 TTL high = 1.0

Block Parameters

Channel vector

Enter numbers between 1 and 32 to select the digital input lines used with this port. This driver allows the selection of individual digital input lines in arbitrary order. The number of elements defines the number of digital lines used.

For example, to use the first eight of the digital inputs for one port, enter

[1,2,3,4,5,6,7,8]

Number the lines beginning with 1 even if this board manufacturer starts numbering the lines with 0.

Sample time

Enter the base sample time or a multiple of the base sample time (- 1 means sample time is inherited).

PCI slot (-1:autosearch)

If only one board of this type is in the target computer, enter - 1 to locate the board.

If two or more boards of this type are in the target computer, enter the bus number and the PCI slot number of the board associated with this driver block. Use the format **[BusNumber,SlotNumber]**.

To determine the bus number and the PCI slot number, type:

```
tg = slrt;  
getPCIInfo(tg, 'installed')
```

External Websites

- www.ni.com

National Instruments PCI-6229 Digital Output

PCI-6229 and PXI-6229 Digital Output block

Library

Simulink Real-Time Library for National Instruments

Note

Models can have multiple digital output blocks for one physical board. In this case, the Simulink Real-Time environment executes the blocks based on their sorted order as determined by the Simulink software.

Each board has one set of digital I/O ports. You can independently set each port to be input or output.

If a digital input block shares channels with a digital output block, the input block reads the last value written to the digital output block on the overlapping channels.

The block compares the value written to each port with 0.5.

Value written	Block writes digital output with a value of...
≥ 0.5	1
< 0.5	0

Scaling of Output to Input

I/O Module Output	Block Input Data Type	Scaling
TTL	Double	< 0.5 = TTL low ≥ 0.5 = TTL high

Block Parameters

Channel vector

Enter numbers between 1 and 32 to select the digital output lines used with this port. This driver allows the selection of individual digital output lines in arbitrary order. The number of elements defines the number of digital lines used.

For example, to use the first eight digital outputs for, enter

```
[1,2,3,4,5,6,7,8]
```

Number the lines beginning with 1 even if this board manufacturer starts numbering the lines with 0.

Reset vector

The reset vector controls the behavior of the channel at model termination. Enter a scalar or a vector that is the same length as the channel vector. If you specify a scalar value, that setting is replicated over the channel vector. If you specify a value of 1, the corresponding channel is reset to the value specified in the initial value vector. If you specify a value of 0, the channel remains at the last value attained while the model was running.

Initial value vector

The initial value vector contains the initial values (0 or 1) of the output channels. Enter a scalar or a vector that is the same length as the channel vector. If you enter a scalar, that value is replicated as the initial value over the channel vector. The channels are set to these initial values between the time the model is downloaded and the time it is started.

Sample time

Enter the base sample time or a multiple of the base sample time (- 1 means sample time is inherited).

PCI slot (-1:autosearch)

If only one board of this type is in the target computer, enter - 1 to locate the board.

If two or more boards of this type are in the target computer, enter the bus number and the PCI slot number of the board associated with this driver block. Use the format [**BusNumber,SlotNumber**].

To determine the bus number and the PCI slot number, type:

```
tg = slrt;  
getPCIInfo(tg, 'installed')
```

External Websites

- www.ni.com

National Instruments PCI-6229 Incremental Encoder

Incremental Encoder block for PCI-6229 and PXI-6229 boards

Library

Simulink Real-Time Library for National Instruments

Scaling Input to Output

I/O Module Input	Block Output Data Type	Scaling
TTL level quadrature encoder signals	Double	counts

Block Parameters

Channel

From the list, choose 0 or 1 for the channel counter you want to use. For information on input for these counters, see the National Instruments M Series user manual. The pin associations are:

Counter	Channel 0	Channel 1
A	PFI 8 (Pin 37)	PFI 3 (Pin 42)
B	PFI 10 (Pin 45)	PFI 11 (Pin 46)
Z	PFI 9 (Pin 3)	PFI 4 (Pin 41)

Counting mode

From the list, select a counting mode:

Mode	Description
Quadrature Mode x1	Count on rising edges of the A signal
Quadrature Mode x2	Count on both rising and falling edges of the A signal

Mode	Description
Quadrature Mode x4	Count on both rising and falling edges of both A and B signals

The level of the opposite signal when an edge occurs determines the count direction. For example, a rising edge of A when B is high counts one way, while an edge of A when B is low counts the other. For more information, see the National Instruments M Series user manual.

Initial count

The initial count specifies the initial value for the counter. The block resets the count to this value under the following conditions:

- When the model starts
- When the following is true, which typically occurs once per revolution for a rotary encoder.
 - **Reload at index pulse** check box is selected
 - Index pulse (Z input) is true
 - The phases of A and B match the setting of **Index phase**

Reload at index pulse

Select this check box to reset the counter to the value of Initial count at each index pulse. The reset occurs when:

- The encoder outputs a high level on its index output
- The phases of A and B match the setting of **Index phase**

Index phase

If you have selected the **Reload at index pulse** check box, the **Index phase** parameter specifies the phase of the quadrature signals during which the count reloads with **Initial count**. Your choice of value primarily depends on the particular incremental encoder you use. From the list, select one:

- A low B low
- A low B high
- A high B low
- A high B high

To choose an **Index phase** for reset, use an oscilloscope, triggered on the index pulse, to observe the states of counters A and B. If your choice does not meet the encoder requirements, resets may be inconsistent.

Filter

You can apply a digital debouncing filter to the input pins before processing.

From the list, select a filter value to ignore pulses that are shorter than the filter time. The value of **NONE** indicates that the input is not filtered.

- None
- Minimum pulse width 125 nanoseconds
- Minimum pulse width 6.25 microseconds
- Minimum pulse width 1.25 milliseconds

Sample time

Enter the base sample time or a multiple of the base sample time (- 1 means sample time is inherited).

PCI slot (-1:autosearch)

If only one board of this type is in the target computer, enter - 1 to locate the board.

If two or more boards of this type are in the target computer, enter the bus number and the PCI slot number of the board associated with this driver block. Use the format **[BusNumber, SlotNumber]**.

To determine the bus number and the PCI slot number, type:

```
tg = slrt;  
getPCIInfo(tg, 'installed')
```

External Websites

- www.ni.com

National Instruments PCI-6229 PFI Digital Input

PCI-6229 and PXI-6229 PFI Digital Input block

Library

Simulink Real-Time Library for National Instruments

Description

A model can have more than one PFI digital input block for a given physical board. If a model has more than one digital input block, it executes the blocks in the order that the Simulink software has determined.

The two counters and the PFI digital input and output blocks share the 16 PFI digital I/O lines. Follow these rules when using these blocks:

You can read a PFI bit with this digital input block when...	You cannot read a PFI bit with this digital input block when...
PWM measure block is using the bit	PWM generate block is using the bit
Incremental encoder block is using the bit	PFI digital output block is using the bit

Scaling of Input to Output

I/O Module Input	Block Output Data Type	Scaling
TTL	Double	TTL low ≥ 0.0 TTL high = 1.0

Block Parameters

PFI bit vector (0-15)

This block uses 0 based numbering to reflect the names of the bits described in the National Instruments M Series user manual.

Enter a vector that contains the bits you want to monitor. For example, to read bits PFI 0, PFI 5, and PFI 7, enter

```
[0, 5, 7]
```

Sample time

Enter the base sample time or a multiple of the base sample time (- 1 means sample time is inherited).

PCI slot (-1:autosearch)

If only one board of this type is in the target computer, enter - 1 to locate the board.

If two or more boards of this type are in the target computer, enter the bus number and the PCI slot number of the board associated with this driver block. Use the format **[BusNumber, SlotNumber]**.

To determine the bus number and the PCI slot number, type:

```
tg = slrt;  
getPCIInfo(tg, 'installed')
```

External Websites

- www.ni.com

National Instruments PCI-6229 PFI Digital Output

PFI Digital Output block for PCI-6229 and PXI-6229 boards

Library

Simulink Real-Time Library for National Instruments

Description

A model can have more than one PFI digital input block for a given physical board. If a model has more than one digital input block, it executes the blocks in the order that the Simulink software has determined.

The two counters and the PFI digital input and output blocks share the 16 PFI digital I/O lines. Follow these rules when using these blocks:

- Do not use a PFI bit as a digital output when the PDF digital input block is using the bit.
- Do not use a PFI bit as a digital output when the incremental encoder is using the bit.
- Do not use a PFI bit for digital output when the PWM generate block is using the bit.

Scaling of Output to Input

I/O Module Output	Block Input Data Type	Scaling
TTL	Double	$< 0.5 = \text{TTL low}$ $\geq 0.5 = \text{TTL high}$

Block Parameters

PFI bit vector (0-15)

This block uses 0 based numbering to reflect the names of the bits described in the National Instruments M Series user manual.

Enter a vector that contains the bits you want to control. For example, to write bits PFI 1, PFI 3, and PFI 9, enter

```
[1, 3, 9]
```

Reset vector

The reset vector controls the behavior of the channel at model termination. Enter a scalar or a vector that is the same length as the channel vector. If you specify a scalar value, that setting is replicated over the channel vector. If you specify a value of 1, the corresponding channel is reset to the value specified in the initial value vector. If you specify a value of 0, the channel remains at the last value attained while the model was running.

Initial value vector

The initial value vector contains the initial values (0 or 1) of the block outputs. Enter a scalar or a vector of values, one for each output. If you enter a scalar, the driver replicates that value over the output vector.

The block applies this value as follows:

- The model uses this value when you first download the model to the target computer.
- If you set **Reset vector** to 1, the block output is reset to this value when model execution stops. If the value is greater than 0.5, the block sets output to **HIGH**. If the value is less than or equal to 0.5, the block sets the output to **LOW**.

Sample time

Enter the base sample time or a multiple of the base sample time (-1 means sample time is inherited).

PCI slot (-1:autosearch)

If only one board of this type is in the target computer, enter -1 to locate the board.

If two or more boards of this type are in the target computer, enter the bus number and the PCI slot number of the board associated with this driver block. Use the format [**BusNumber**, **SlotNumber**].

To determine the bus number and the PCI slot number, type:

```
tg = slrt;  
getPCIInfo(tg, 'installed')
```

External Websites

- www.ni.com

National Instruments PCI-6229 PWM Generate

PWM Generate block for PCI-6229 and PXI-6229 boards

Library

Simulink Real-Time Library for National Instruments

Description

Use this block to generate variable frequency and pulse width output.

The M Series boards have two 32-bit counters that you can use to generate pulse trains. Inputs are in counts of the 80 MHz reference frequency on the onboard clock.

- H input is the number of counts that the output is high.
- L input is the number of counts that the output is low.

If the H input goes to 0, the output stays low. If the L input goes to 0, the output stays high. If both are 0, the output goes low.

Block Parameters

Counter

From the list, select the counter, 0 or 1, that you want to use. The output for these counters is on the following pins:

Counter	Pin
0	PFI 12 (Pin 2)
1	PFI 13 (Pin 40)

Initial high count

Enter the number of counts the output is high between the time the Simulink engine calls the `mdlStart` routine for this block and the first time it calls `mdlOutputs`. This

length of time depends on the number of blocks in the model and the sorted order as determined by the Simulink software.

If you enter a value of 0, the output stays low until the first time the Simulink engine calls `mdlOutputs`.

Initial low count

Enter the number of counts the output is low between the time the Simulink engine calls the `mdlStart` routine for this block and the first time it calls `mdlOutputs`. This length of time depends on the number of blocks in the model and the sorted order as determined by the Simulink software. If you enter a value of 0, the output stays high until the first time the Simulink engine calls `mdlOutputs`, unless you have also set `H` to 0.

Arm input

Select this check box to add a third input port to the block.

- If the input connected to this port is greater than 0.5, the block arms the counter. Output then occurs.
- If the input connected to this port is less than or equal to 0.5, the block disarms the counter and the output goes to the level of the value in the **Disarm level** parameter.

Disarm level

From the list, select the disarm level **Disarm to LOW** or **Disarm to HIGH**. If the model disarms the block and the level of the value is **Arm input**, the output goes to the level you select here.

Stop level

From the list, select the stop level **Stop to LOW** or **Stop to HIGH**. When model execution stops, the output goes to the level you choose here.

Sample time

Enter the base sample time or a multiple of the base sample time (-1 means sample time is inherited).

PCI slot (-1:autosearch)

If only one board of this type is in the target computer, enter -1 to locate the board.

If two or more boards of this type are in the target computer, enter the bus number and the PCI slot number of the board associated with this driver block. Use the format **[BusNumber,SlotNumber]**.

To determine the bus number and the PCI slot number, type:

```
tg = slrt;  
getPCIInfo(tg, 'installed')
```

External Websites

- www.ni.com

National Instruments PCI-6229 PWM Measure

PWM Measure block for PCI-6229 and PXI-6229 boards

Library

Simulink Real-Time Library for National Instruments

Description

Use this block to measure the pulse width or the period of a signal.

To measure the pulse width of a signal, connect the signal to the gate, as follows:

Counter	Gate Pin
0	PFI 9 (Pin 3)
1	PFI 4 (Pin 41)

The input waveform must have fast rise and fall times and conform to TTL signal levels of [0,5] volts. Use external signal conditioning to achieve these levels. If you input a sine wave, the decision points are less definite and the measurement is noisy. In extreme cases, the gate can transition multiple times during a slow signal transition.

This block does not queue or buffer measurements. If the gate changes state, the driver holds the current count, overwriting the previous value.

This block returns the length of the last gate period before the block executes.

To compute the duty cycle percentage, use two counters. Because the period of a cycle is H counter + L counter, you can measure two of these counters and compute the third.

You cannot measure a 0 width pulse.

Block Parameters

Counter

From the list, select a counter, 0 or 1.

Trigger mode

From the list, select the gating mode to use:

Mode	Description
Width of Gate High	Returns the number of 80 MHz cycles that occur when a single cycle of the input is high.
Width of Gate Low	Returns the number of 80 MHz cycles that occur when a single cycle of the input is low.
Between Rising Edges	Returns the number of 80 MHz cycles that occur between rising edges of the input signal. This cycle is the full period of the input signal.
Between Falling Edges	Returns the number of 80 MHz cycles that occur between falling edges of the input signal. This cycle is the full period of the input signal.

If the input signal has both fast rise and fall edges, **Between Rising Edges** and **Between Falling Edges** return the same value. If the input is asymmetric, one of these options can give a better result than the other.

Filter

You can apply a digital debouncing filter to the input pins before processing.

From the list, select a filter value to ignore pulses that are shorter than the filter time. The block ignores pulses shorter than the chosen duration. The value of **None** indicates that the input is not filtered

- None
- Minimum pulse width 125 nanoseconds
- Minimum pulse width 6.25 microseconds
- Minimum pulse width 1.25 milliseconds

Sample time

Enter the base sample time or a multiple of the base sample time (- 1 means sample time is inherited).

PCI slot (-1:autosearch)

If only one board of this type is in the target computer, enter - 1 to locate the board.

If two or more boards of this type are in the target computer, enter the bus number and the PCI slot number of the board associated with this driver block. Use the format **[BusNumber,SlotNumber]**.

To determine the bus number and the PCI slot number, type:

```
tg = slrt;  
getPCIInfo(tg, 'installed')
```

External Websites

- www.ni.com

National Instruments PCI-6251

Support for PCI-6251, PCIe-6251, PXI-6251, and PXIe-6251 boards

Board

National Instruments PCI-6251, PCIe-6251, PXI-6251, PXIe-6251

General Description

The 6251 M-series boards are high-speed data acquisition I/O boards with up to 16 single-ended or 8 differential 16-bit analog inputs, two 16-bit analog outputs, 24 digital I/O lines, and two 32-bit counters.

The Simulink Real-Time block library supports the 6251 boards with these driver blocks:

- National Instruments PCI-6251 Analog Input
- National Instruments PCI-6251 Analog Output
- National Instruments PCI-6251 Digital Input
- National Instruments PCI-6251 Digital Output
- National Instruments PCI-6251 Incremental Encoder
- National Instruments PCI-6251 PFI Digital Input
- National Instruments PCI-6251 PFI Digital Output
- National Instruments PCI-6251 PWM Generate
- National Instruments PCI-6251 PWM Measure

Board Characteristics

Board name	PCI-6251, PCIe-6251, PXI-6251, PXIe-6251
Manufacturer	National Instruments
Bus type	PCI, PCIe, PXI, PXIe (use PCI version of blocks)

Multiple block instance support

A/D: No, D/A: No, Digital I/O: Yes

Multiple board support

Yes

External Websites

- www.ni.com

National Instruments PCI-6251 Analog Input

Analog Input block for PCI-6251, PCIe-6251, PXI-6251, and PXIe-6251 boards

Library

Simulink Real-Time Library for National Instruments

Scaling of Input to Output

I/O Module Input	Block Output Data Type	Scaling
Volts	Double	1

Block Parameters

Channel vector

Enter numbers between 1 and 16. This driver allows you to enter channel numbers in arbitrary order.

For example, to use the first, second, and fifth channels, enter

[1,2,5]

Number the lines beginning with 1 even if this board manufacturer starts numbering the lines with 0.

Range vector

Enter a range code for each of the channels in the channel vector. You can specify one value to replicate over the channel vector, or specify one for each channel. This driver allows each channel to be different. This board works only in bipolar mode.

The following table is a list of the ranges for this driver and the corresponding range codes.

Input Range (V)	Range Code
-10 to +10	10
-5 to +5	5

Input Range (V)	Range Code
-2 to +2	2
-1 to +1	1
-.5 to +.5	.5
-0.2 to +0.2	0.2
-0.1 to +0.1	0.1

For example, if the first channel is -10 to +10 volts and the second and fifth channels are -1 to +1 volts, enter

[10,1,1]

Input coupling vector

Enter a coupling code for each of the channels in the channel vector. You can replicate one value over the channel vector, or specify one for each channel. This driver allows a different coupling for each channel.

The following table is a list of the couplings for this driver and the corresponding coupling codes.

Coupling	Coupling Code	Description
RSE	0	Analog input line connected to the positive input of the PGIA. Analog input ground (AIGND) internally connected to the negative input of the PGIA. See the National Instruments user manual.
NRSE	1	Analog input line connected to the positive input of the PGIA. Analog input sense (AISENSE) connected to the negative input of the PGIA. See the National Instruments user manual.
DIFF	2	First analog input line connected to the positive input of the PGIA. Second analog input line connected to the negative input of the PGIA. See the National Instruments user manual.

For example, if the first and second channels are single input and the fifth channel is a differential input, enter

[0,0,2]

National Instruments boards use a zero-based number scheme for differential mode channel pairs. Simulink Real-Time drivers use a one-based number scheme that adds a 1 to the I/O module number, as shown in the following table:

Zero-Based Channel Number		One-Based Channel Number	
+	-	+	-
0	8	1	9
1	9	2	10
2	10	3	11
3	11	4	12
4	12	5	13
5	13	6	14
6	14	7	15
7	15	8	16

The I/O module uses a second input 8 channels higher than the first channel as the negative input of the pair. In the example above, the I/O module would use the 13th channel as a differential input with the fifth channel.

If the module is set up for differential mode, you can read the data from either of the channels in the differential pair. For example, if you have a differential pair of 1 and 9, you can read the data from channel 1 or channel 9. However, you might want to read the lower channel number of the pair because it remains unchanged when you switch the input mode between single-ended and differential.

Scan interval

If **Channel vector** has more than one channel in it, enter the time between sampling different channels. Because execution waits for data to be available, this value increases the time to execute the block. If you enter a shorter time, you get the minimum 1e-6. If you enter a time smaller than this value, the time will still be 4e-6, which is the fastest this board can acquire data. See the National Instruments user manual for a discussion about settling time and the need to control the time between sampling different channels depending on the impedance of the signal source.

Sample time

Enter the base sample time or a multiple of the base sample time (-1 means sample time is inherited).

PCI slot (-1:autosearch)

If only one board of this type is in the target computer, enter - 1 to locate the board.

If two or more boards of this type are in the target computer, enter the bus number and the PCI slot number of the board associated with this driver block. Use the format **[BusNumber,SlotNumber]**.

To determine the bus number and the PCI slot number, type:

```
tg = slrt;  
getPCIInfo(tg, 'installed')
```

External Websites

- www.ni.com

National Instruments PCI-6251 Analog Output

Analog Output block for PCI-6251, PCIE-6251, PXI-6251, and PXIE-6251 boards

Library

Simulink Real-Time Library for National Instruments

Scaling of Output to Input

I/O Module Output	Block Input Data Type	Scaling
Volts	Double	1

Block Parameters

Channel vector

Enter 1 or 2. This driver allows the selection of individual D/A channels in arbitrary order. The number of elements defines the number of D/A channels used. For example, to use both of the analog output channels, enter

[1,2]

Number the channels begin with 1 even if this board manufacturer starts numbering the channels with 0.

Range vector

Enter a range code for each of the channels in the channel vector. The range vector must be the same length as the channel vector. This board allows the range of each channel to be different.

The following table is a list of the ranges for this driver and the corresponding range codes.

Input Range (V)	Range Code
-10 to +10	-10
-5 to +5	-5

Input Range (V)	Range Code
$V_{ref} \times sig$, where $-1 \leq sig \leq +1$	APFIO

For example, if the first channel is -10 to +10 volts and the second channel is -5 to +5 volts, enter

[10,5]

Reset vector

The reset vector controls the behavior of the channel at model termination. Enter a scalar or a vector that is the same length as the channel vector. If you specify a scalar value, that setting is replicated over the channel vector. If you specify a value of 1, the corresponding channel is reset to the value specified in the initial value vector. If you specify a value of 0, the channel remains at the last value attained while the model was running.

Initial value vector

The initial value vector contains the initial voltage values for the output channels. Enter a scalar or a vector that is the same length as the channel vector. If you specify a scalar value, that value is replicated as the initial value over the channel vector. The channels are set to the initial values between the time the model is downloaded and the time it is started.

Sample time

Enter the base sample time or a multiple of the base sample time (-1 means sample time is inherited).

PCI slot (-1:autosearch)

If only one board of this type is in the target computer, enter -1 to locate the board.

If two or more boards of this type are in the target computer, enter the bus number and the PCI slot number of the board associated with this driver block. Use the format [**BusNumber**, **SlotNumber**].

To determine the bus number and the PCI slot number, type:

```
tg = slrt;
getPCIInfo(tg, 'installed')
```

External Websites

- www.ni.com

National Instruments PCI-6251 Digital Input

Digital Input block for PCI-6251, PCIE-6251, PXI-6251, and PXIE-6251 boards

Library

Simulink Real-Time Library for National Instruments

Note

Models can have multiple digital input blocks for one physical board. In this case, the Simulink Real-Time environment executes the blocks based on their sorted order as determined by the Simulink software.

Each board has one set of static digital I/O ports. You can independently configure each port to be input or output.

If a digital input block shares channels with a digital output block, the input block reads the last value written to the digital output block on the overlapping channels.

Scaling of Input to Output

I/O Module Input	Block Output Data Type	Scaling
TTL	Double	TTL low ≥ 0.0 TTL high = 1.0

Block Parameters

Channel vector

Enter numbers between 1 and 8 to select the digital input lines used with this port. This driver allows the selection of individual digital input lines in arbitrary order. The number of elements defines the number of digital lines used.

For example, to use the first eight digital inputs for one port, enter

[1,2,3,4,5,6,7,8]

Number the lines beginning with 1 even if this board manufacturer starts numbering the lines with 0.

Sample time

Enter the base sample time or a multiple of the base sample time (- 1 means sample time is inherited).

PCI slot (-1:autosearch)

If only one board of this type is in the target computer, enter - 1 to locate the board.

If two or more boards of this type are in the target computer, enter the bus number and the PCI slot number of the board associated with this driver block. Use the format **[BusNumber,SlotNumber]**.

To determine the bus number and the PCI slot number, type:

```
tg = slrt;  
getPCIInfo(tg, 'installed')
```

External Websites

- www.ni.com

National Instruments PCI-6251 Digital Output

Digital Output block for PCI-6251, PCIe-6251, PXI-6251, and PXIe-6251 boards

Library

Simulink Real-Time Library for National Instruments

Note

Models can have multiple digital output blocks for one physical board. In this case, the Simulink Real-Time environment executes the blocks based on their sorted order as determined by the Simulink software.

Each board has one set of digital I/O ports. You can independently each port to be input or output.

If a digital input block shares channels with a digital output block, the input block reads the last value written to the digital output block on the overlapping channels.

The block compares the value written to each port with 0.5.

Value written	Block writes digital output with a value of...
≥ 0.5	1
< 0.5	0

Scaling of Output to Input

I/O Module Output	Block Input Data Type	Scaling
TTL	Double	$< 0.5 = \text{TTL low}$ $\geq 0.5 = \text{TTL high}$

Block Parameters

Channel vector

Enter numbers between 1 and 8 to select the digital output lines used with this port. This driver allows the selection of individual digital output lines in arbitrary order. The number of elements defines the number of digital lines used.

For example, to use the first eight digital outputs, enter

```
[1,2,3,4,5,6,7,8]
```

Number the lines beginning with 1 even if this board manufacturer starts numbering the lines with 0.

Reset vector

The reset vector controls the behavior of the channel at model termination. Enter a scalar or a vector that is the same length as the channel vector. If you specify a scalar value, that setting is replicated over the channel vector. If you specify a value of 1, the corresponding channel is reset to the value specified in the initial value vector. If you specify a value of 0, the channel remains at the last value attained while the model was running.

Initial value vector

The initial value vector contains the initial values (0 or 1) of the output channels. Enter a scalar or a vector that is the same length as the channel vector. If you enter a scalar, that value is replicated as the initial value over the channel vector. The channels are set to these initial values between the time the model is downloaded and the time it is started.

Sample time

Enter the base sample time or a multiple of the base sample time (- 1 means sample time is inherited).

PCI slot (-1:autosearch)

If only one board of this type is in the target computer, enter - 1 to locate the board.

If two or more boards of this type are in the target computer, enter the bus number and the PCI slot number of the board associated with this driver block. Use the format **[BusNumber,SlotNumber]**.

To determine the bus number and the PCI slot number, type:

```
tg = slrt;  
getPCIInfo(tg, 'installed')
```

External Websites

- www.ni.com

National Instruments PCI-6251 Incremental Encoder

Incremental Encoder block for PCI-6251, PCIE-6251, PXI-6251, and PXIE-6251 boards

Library

Simulink Real-Time Library for National Instruments

Scaling Input to Output

I/O Module Input	Block Output Data Type	Scaling
TTL level quadrature encoder signals	Double	counts

Block Parameters

Channel

From the list, choose 0 or 1 for the channel counter you want to use. For information on input for these counters, see the National Instruments M Series user manual. The pin associations are:

Counter	Channel 0	Channel 1
A	PFI 8 (Pin 37)	PFI 3 (Pin 42)
B	PFI 10 (Pin 45)	PFI 11 (Pin 46)
Z	PFI 9 (Pin 3)	PFI 4 (Pin 41)

Counting mode

From the list, select a counting mode:

Mode	Description
Quadrature Mode x1	Count on rising edges of the A signal
Quadrature Mode x2	Count on both rising and falling edges of the A signal

Mode	Description
Quadrature Mode x4	Count on both rising and falling edges of both A and B signals

The level of the opposite signal when an edge occurs determines the count direction. For example, a rising edge of A when B is high counts one way, while an edge of A when B is low counts the other. For more information, see the National Instruments M Series user manual.

Initial count

The initial count specifies the initial value for the counter. The block resets the count to this value under the following conditions:

- When the model starts
- When the following is true, which typically occurs once per revolution for a rotary encoder.
 - **Reload at index pulse** check box is selected
 - Index pulse (Z input) is true
 - The phases of A and B match the setting of **Index phase**

Reload at index pulse

Select this check box to reset the counter to the value of **Initial count** at each index pulse. The reset occurs when:

- The encoder outputs a high level on its index output
- The phases of A and B match the setting of **Index phase**

Index phase

If you have selected the **Reload at index pulse** check box, the **Index phase** parameter specifies the phase of the quadrature signals during which the count reloads with **Initial count**. Your choice of value primarily depends on the particular incremental encoder you use. From the list, select one:

- A low B low
- A low B high
- A high B low
- A high B high

To choose an **Index phase** for reset, use an oscilloscope, triggered on the index pulse, to observe the states of counters A and B. If your choice does not meet the encoder requirements, resets may be inconsistent.

Filter

You can apply a digital debouncing filter to the input pins before processing.

From the list, select a filter value to ignore pulses that are shorter than the filter time. The value of **NONE** indicates that the input is not filtered.

- None
- Minimum pulse width 125 nanoseconds
- Minimum pulse width 6.25 microseconds
- Minimum pulse width 1.25 milliseconds

Sample time

Enter the base sample time or a multiple of the base sample time (- 1 means sample time is inherited).

PCI slot (-1:autosearch)

If only one board of this type is in the target computer, enter - 1 to locate the board.

If two or more boards of this type are in the target computer, enter the bus number and the PCI slot number of the board associated with this driver block. Use the format **[BusNumber, SlotNumber]**.

To determine the bus number and the PCI slot number, type:

```
tg = slrt;  
getPCIInfo(tg, 'installed')
```

External Websites

- www.ni.com

National Instruments PCI-6251 PFI Digital Input

PFI Digital Input block for PCI-6251, PCIe-6251, PXI-6251, and PXIe-6251 boards

Library

Simulink Real-Time Library for National Instruments

Description

A model can have more than one PFI digital input block for a given physical board. If a model has more than one digital input block, it executes the blocks in the order that the Simulink software has determined.

The two counters and the PFI digital input and output blocks share the 16 PFI digital I/O lines. Follow these rules when using these blocks:

You can read a PFI bit with this digital input block when...	You cannot read a PFI bit with this digital input block when...
PWM measure block is using the bit	PWM generate block is using the bit
Incremental encoder block is using the bit	PFI digital output block is using the bit

Scaling of Input to Output

I/O Module Input	Block Output Data Type	Scaling
TTL	Double	TTL low ≥ 0.0 TTL high = 1.0

Block Parameters

PFI bit vector (0-15)

This block uses 0 based numbering to reflect the names of the bits described in the National Instruments M Series user manual.

Enter a vector that contains the bits you want to monitor. For example, to read bits PFI 0, PFI 5, and PFI 7, enter

```
[0, 5, 7]
```

Sample time

Enter the base sample time or a multiple of the base sample time (- 1 means sample time is inherited).

PCI slot (-1:autosearch)

If only one board of this type is in the target computer, enter - 1 to locate the board.

If two or more boards of this type are in the target computer, enter the bus number and the PCI slot number of the board associated with this driver block. Use the format **[BusNumber, SlotNumber]**.

To determine the bus number and the PCI slot number, type:

```
tg = slrt;  
getPCIInfo(tg, 'installed')
```

External Websites

- www.ni.com

National Instruments PCI-6251 PFI Digital Output

PFI Digital Output block for PCI-6251, PCIe-6251, PXI-6251, and PXIe-6251 boards

Library

Simulink Real-Time Library for National Instruments

Description

A model can have more than one PFI digital input block for a given physical board. If a model has more than one digital input block, it executes the blocks in the order that the Simulink software has determined.

The two counters and the PFI digital input and output blocks share the 16 PFI digital I/O lines. Follow these rules when using these blocks:

- Do not use a PFI bit as a digital output when the PDF digital input block is using the bit.
- Do not use a PFI bit as a digital output when the incremental encoder is using the bit.
- Do not use a PFI bit for digital output when the PWM generate block is using the bit.

Scaling of Output to Input

I/O Module Output	Block Input Data Type	Scaling
TTL	Double	< 0.5 = TTL low ≥ 0.5 = TTL high

Block Parameters

PFI bit vector (0-15)

This block uses 0 based numbering to reflect the names of the bits described in the National Instruments M Series user manual.

Enter a vector that contains the bits you want to control. For example, to write bits PFI 1, PFI 3, and PFI 9, enter

```
[1, 3, 9]
```

Reset vector

The reset vector controls the behavior of the channel at model termination. Enter a scalar or a vector that is the same length as the channel vector. If you specify a scalar value, that setting is replicated over the channel vector. If you specify a value of 1, the corresponding channel is reset to the value specified in the initial value vector. If you specify a value of 0, the channel remains at the last value attained while the model was running.

Initial value vector

The initial value vector contains the initial values (0 or 1) of the block outputs. Enter a scalar or a vector of values, one for each output. If you enter a scalar, the driver replicates that value over the output vector.

The block applies this value as follows:

- The model uses this value when you first download the model to the target computer.
- If you set **Reset vector** to 1, the block output is reset to this value when model execution stops. If the value is greater than 0.5, the block sets output to **HIGH**. If the value is less than or equal to 0.5, the block sets the output to **LOW**.

Sample time

Enter the base sample time or a multiple of the base sample time (-1 means sample time is inherited).

PCI slot (-1:autosearch)

If only one board of this type is in the target computer, enter -1 to locate the board.

If two or more boards of this type are in the target computer, enter the bus number and the PCI slot number of the board associated with this driver block. Use the format [**BusNumber**, **SlotNumber**].

To determine the bus number and the PCI slot number, type:

```
tg = slrt;  
getPCIInfo(tg, 'installed')
```

External Websites

- www.ni.com

National Instruments PCI-6251 PWM Generate

PWM Generate block for PCI-6251, PCIe-6251, PXI-6251, and PXIe-6251 boards

Library

Simulink Real-Time Library for National Instruments

Description

Use this block to generate variable frequency and pulse width output.

The M Series boards have two 32-bit counters that you can use to generate pulse trains. Inputs are in counts of the 80 MHz reference frequency on the onboard clock.

- H input is the number of counts that the output is high.
- L input is the number of counts that the output is low.

If the H input goes to 0, the output stays low. If the L input goes to 0, the output stays high. If both are 0, the output goes low.

Block Parameters

Counter

From the list, select the counter, 0 or 1, that you want to use. The output for these counters is on the following pins:

Counter	Pin
0	PFI 12 (Pin 2)
1	PFI 13 (Pin 40)

Initial high count

Enter the number of counts the output is high between the time the Simulink engine calls the `mdlStart` routine for this block and the first time it calls `mdlOutputs`. This

length of time depends on the number of blocks in the model and the sorted order as determined by the Simulink software.

If you enter a value of 0, the output stays low until the first time the Simulink engine calls `mdlOutputs`.

Initial low count

Enter the number of counts the output is low between the time the Simulink engine calls the `mdlStart` routine for this block and the first time it calls `mdlOutputs`. This length of time depends on the number of blocks in the model and the sorted order as determined by the Simulink software. If you enter a value of 0, the output stays high until the first time the Simulink engine calls `mdlOutputs`, unless you have also set `H` to 0.

Arm input

Select this check box to add a third input port to the block.

- If the input connected to this port is greater than 0.5, the block arms the counter. Output then occurs.
- If the input connected to this port is less than or equal to 0.5, the block disarms the counter and the output goes to the level of the value in the **Disarm level** parameter.

Disarm level

From the list, select the disarm level **Disarm to LOW** or **Disarm to HIGH**. If the model disarms the block and the level of the value is **Arm input**, the output goes to the level you select here.

Stop level

From the list, select the stop level **Stop to LOW** or **Stop to HIGH**. When model execution stops, the output goes to the level you choose here.

Sample time

Enter the base sample time or a multiple of the base sample time (-1 means sample time is inherited).

PCI slot (-1:autosearch)

If only one board of this type is in the target computer, enter -1 to locate the board.

If two or more boards of this type are in the target computer, enter the bus number and the PCI slot number of the board associated with this driver block. Use the format **[BusNumber, SlotNumber]**.

To determine the bus number and the PCI slot number, type:

```
tg = slrt;  
getPCIInfo(tg, 'installed')
```

External Websites

- www.ni.com

National Instruments PCI-6251 PWM Measure

PWM Measure block for PCI-6251, PCIe-6251, PXI-6251, and PXIe-6251 boards

Library

Simulink Real-Time Library for National Instruments

Description

Use this block to measure the pulse width or the period of a signal.

To measure the pulse width of a signal, connect the signal to the gate, as follows:

Counter	Gate Pin
0	PFI 9 (Pin 3)
1	PFI 4 (Pin 41)

The input waveform must have fast rise and fall times and conform to TTL signal levels of [0,5] volts. Use external signal conditioning to achieve these levels. If you input a sine wave, the decision points are less definite and the measurement is noisy. In extreme cases, the gate can transition multiple times during a slow signal transition.

This block does not queue or buffer measurements. If the gate changes state, the driver holds the current count, overwriting the previous value.

This block returns the length of the last gate period before the block executes.

To compute the duty cycle percentage, use two counters. Because the period of a cycle is H counter + L counter, you can measure two of these counters and compute the third.

You cannot measure a 0 width pulse.

Block Parameters

Counter

From the list, select a counter, 0 or 1.

Trigger mode

From the list, select the gating mode to use:

Mode	Description
Width of Gate High	Returns the number of 80 MHz cycles that occur when a single cycle of the input is high.
Width of Gate Low	Returns the number of 80 MHz cycles that occur when a single cycle of the input is low.
Between Rising Edges	Returns the number of 80 MHz cycles that occur between rising edges of the input signal. This cycle is the full period of the input signal.
Between Falling Edges	Returns the number of 80 MHz cycles that occur between falling edges of the input signal. This cycle is the full period of the input signal.

If the input signal has both fast rise and fall edges, **Between Rising Edges** and **Between Falling Edges** return the same value. If the input is asymmetric, one of these options can give a better result than the other.

Filter

You can apply a digital debouncing filter to the input pins before processing.

From the list, select a filter value to ignore pulses that are shorter than the filter time. The block ignores pulses shorter than the chosen duration. The value of **None** indicates that the input is not filtered

- None
- Minimum pulse width 125 nanoseconds
- Minimum pulse width 6.25 microseconds
- Minimum pulse width 1.25 milliseconds

Sample time

Enter the base sample time or a multiple of the base sample time (- 1 means sample time is inherited).

PCI slot (-1:autosearch)

If only one board of this type is in the target computer, enter - 1 to locate the board.

If two or more boards of this type are in the target computer, enter the bus number and the PCI slot number of the board associated with this driver block. Use the format **[BusNumber,SlotNumber]**.

To determine the bus number and the PCI slot number, type:

```
tg = slrt;  
getPCIInfo(tg, 'installed')
```

External Websites

- www.ni.com

National Instruments PCI-6259

Support for PCI-6259, PCIe-6259, PXI-6259, and PXIe-6259 boards

Board

National Instruments PCI-6259, PCIe-6259, PXI-6259, PXIe-6259

General Description

The 6259 M-series boards are data acquisition I/O boards with up to 32 single-ended or 16 differential 16-bit analog inputs, four 16-bit analog outputs, 48 digital I/O lines, and two 32-bit counters.

The Simulink Real-Time block library supports the 6259 boards with these driver blocks:

- National Instruments PCI-6259 Analog Input
- National Instruments PCI-6259 Analog Output
- National Instruments PCI-6259 Digital Input
- National Instruments PCI-6259 Digital Output
- National Instruments PCI-6259 Incremental Encoder
- National Instruments PCI-6259 PFI Digital Input
- National Instruments PCI-6259 PFI Digital Output
- National Instruments PCI-6259 PWM Generate
- National Instruments PCI-6259 PWM Measure

Board Characteristics

Board name	PCI-6259, PCIe-6259, PXI-6259, PXIe-6259
Manufacturer	National Instruments
Bus type	PCI, PCIe, PXI, PXIe (use PCI version of blocks)

Multiple block instance support
Multiple board support

A/D: No, D/A: No, Digital I/O: Yes
Yes

External Websites

- www.ni.com

National Instruments PCI-6259 Analog Input

Analog Input block for PCI-6259, PCIe-6259, PXI-6259, and PXIe-6259 boards

Library

Simulink Real-Time Library for National Instruments

Scaling of Input to Output

I/O Module Input	Block Output Data Type	Scaling
Volts	Double	1

Block Parameters

Channel vector

Enter numbers between 1 and 32. This driver allows you to enter channel numbers in arbitrary order.

For example, to use the first, second, and fifth channels, enter

```
[1,2,5]
```

Number the lines beginning with 1 even if this board manufacturer starts numbering the lines with 0.

Range vector

Enter a range code for each of the channels in the channel vector. You can specify one value to replicate over the channel vector, or specify one for each channel. This driver allows each channel to be different. This board works only in bipolar mode.

The following table is a list of the ranges for this driver and the corresponding range codes.

Input Range (V)	Range Code
-10 to +10	10

Input Range (V)	Range Code
-5 to +5	5
-2 to +2	2
-1 to +1	1
-0.5 to +0.5	0.5
-0.2 to +0.2	0.2
-0.1 to +0.1	0.1

For example, if the first channel is -10 to +10 volts and the second and fifth channels are -1 to +1 volts, enter

[10, 1, 1]

Input coupling vector

Enter a coupling code for each of the channels in the channel vector. You can replicate one value over the channel vector, or specify one for each channel. This driver allows a different coupling for each channel.

The following table is a list of the couplings for this driver and the corresponding coupling codes.

Coupling	Coupling Code	Description
RSE	0	Analog input line connected to the positive input of the PGIA. Analog input ground (AIGND) internally connected to the negative input of the PGIA. See the National Instruments user manual.
NRSE	1	Analog input line connected to the positive input of the PGIA. Analog input sense (AISENSE) connected to the negative input of the PGIA. See the National Instruments user manual.
DIFF	2	First analog input line connected to the positive input of the PGIA. Second analog input line connected to the negative input of the PGIA. See the National Instruments user manual.

For example, if the first and second channels are single input and the fifth channel is a differential input, enter

[0,0,2]

National Instruments boards use a zero-based number scheme for differential mode channel pairs. Simulink Real-Time drivers use a one-based number scheme that adds a 1 to the channel number, as shown in the following table:

Zero-Based Channel Number		One-Based Channel Number	
+	-	+	-
0	8	1	9
1	9	2	10
2	10	3	11
3	11	4	12
4	12	5	13
5	13	6	14
6	14	7	15
7	15	8	16
16	24	17	25
17	25	18	26
18	26	19	27
19	27	20	28
20	28	21	29
21	29	22	30
22	30	23	31
23	31	24	32

The I/O module uses a second input 8 channels higher than the first channel as the negative input of the pair. In the example above, the I/O module would use the 13th channel as a differential input with the fifth channel.

If the module is set up for differential mode, you can read the data from either of the channels in the differential pair. For example, if you have a differential pair of 1 and 9, you can read the data from channel 1 or channel 9. However, you might want to read the lower channel number of the pair because it remains unchanged when you switch the input mode between single-ended and differential.

Scan interval

If **Channel vector** has more than one channel in it, enter the time between sampling different channels. Because execution waits for data to be available, this value increases the time to execute the block. If you enter a shorter time, you get the minimum 1e-6. If you enter a time smaller than this value, the time will still be 4e-6, which is the fastest this board can acquire data. See the National Instruments user manual for a discussion about settling time and the need to control the time between sampling different channels depending on the impedance of the signal source.

Sample time

Enter the base sample time or a multiple of the base sample time (- 1 means sample time is inherited).

PCI slot (-1:autosearch)

If only one board of this type is in the target computer, enter - 1 to locate the board.

If two or more boards of this type are in the target computer, enter the bus number and the PCI slot number of the board associated with this driver block. Use the format [**BusNumber**, **SlotNumber**].

To determine the bus number and the PCI slot number, type:

```
tg = slrt;  
getPCIInfo(tg, 'installed')
```

External Websites

- www.ni.com

National Instruments PCI-6259 Analog Output

Analog Output block for PCI-6259, PCIe-6259, PXI-6259, and PXIe-6259 boards

Library

Simulink Real-Time Library for National Instruments

Scaling of Output to Input

I/O Module Output	Block Input Data Type	Scaling
Volts	Double	1

Block Parameters

Channel vector

Enter 1 to 4. This driver allows the selection of individual D/A channels in arbitrary order. The number of elements defines the number of D/A channels used. For example, to use all of the analog output channels, enter

[1,2,3,4]

Number the channels begin with 1 even if this board manufacturer starts numbering the channels with 0.

Range vector

Enter a range code for each of the channels in the channel vector. The range vector must be the same length as the channel vector. This driver allows each channel to be different. This board works only in bipolar mode.

The following table is a list of the ranges for this driver and the corresponding range codes.

Input Range (V)	Range Code
-10 to +10	-10

Input Range (V)	Range Code
-5 to +5	-5
$V_{ref} \times sig$, where $-1 \leq sig \leq +1$	APFI0
$V_{ref} \times sig$, where $-1 \leq sig \leq +1$	APFI1

For example, if the first channel is -10 to +10 volts and the second channel -5 to +5 volts, enter

[-10, -5]

Reset vector

The reset vector controls the behavior of the channel at model termination. Enter a scalar or a vector that is the same length as the channel vector. If you specify a scalar value, that setting is replicated over the channel vector. If you specify a value of 1, the corresponding channel is reset to the value specified in the initial value vector. If you specify a value of 0, the channel remains at the last value attained while the model was running.

Initial value vector

The initial value vector contains the initial voltage values for the output channels. Enter a scalar or a vector that is the same length as the channel vector. If you specify a scalar value, that value is replicated as the initial value over the channel vector. The channels are set to the initial values between the time the model is downloaded and the time it is started.

Sample time

Enter the base sample time or a multiple of the base sample time (- 1 means sample time is inherited).

PCI slot (-1:autosearch)

If only one board of this type is in the target computer, enter - 1 to locate the board.

If two or more boards of this type are in the target computer, enter the bus number and the PCI slot number of the board associated with this driver block. Use the format **[BusNumber, SlotNumber]**.

To determine the bus number and the PCI slot number, type:

```
tg = slrt;
getPCIInfo(tg, 'installed')
```

External Websites

- www.ni.com

National Instruments PCI-6259 Digital Input

Digital Input block for PCI-6259, PCIe-6259, PXI-6259, and PXIe-6259 boards

Library

Simulink Real-Time Library for National Instruments

Note

Models can have multiple digital input blocks for one physical board. In this case, the Simulink Real-Time environment executes the blocks based on their sorted order as determined by the Simulink software.

Each board has one set of static digital I/O ports. You can independently configure each port to be input or output.

If a digital input block shares channels with a digital output block, the input block reads the last value written to the digital output block on the overlapping channels.

Scaling of Input to Output

I/O Module Input	Block Output Data Type	Scaling
TTL	Double	TTL low ≥ 0.0 TTL high = 1.0

Block Parameters

Channel vector

Enter numbers between 1 and 32 to select the digital input lines used with this port. This driver allows the selection of individual digital input lines in arbitrary order. The number of elements defines the number of digital lines used.

For example, to use the first eight digital inputs for one port, enter

[1,2,3,4,5,6,7,8]

Number the lines beginning with 1 even if this board manufacturer starts numbering the lines with 0.

Sample time

Enter the base sample time or a multiple of the base sample time (- 1 means sample time is inherited).

PCI slot (-1:autosearch)

If only one board of this type is in the target computer, enter - 1 to locate the board.

If two or more boards of this type are in the target computer, enter the bus number and the PCI slot number of the board associated with this driver block. Use the format **[BusNumber,SlotNumber]**.

To determine the bus number and the PCI slot number, type:

```
tg = slrt;  
getPCIInfo(tg, 'installed')
```

External Websites

- www.ni.com

National Instruments PCI-6259 Digital Output

Digital Output block for PCI-6259, PCIe-6259, PXI-6259, and PXIe-6259 boards

Library

Simulink Real-Time Library for National Instruments

Note

Models can have multiple digital output blocks for one physical board. In this case, the Simulink Real-Time environment executes the blocks based on their sorted order as determined by the Simulink software.

Each board has one set of digital I/O ports. You can independently configure each port to be input or output.

If a digital input block shares channels with a digital output block, the input block reads the last value written to the digital output block on the overlapping channels.

The block compares the value written to each port with 0.5.

Value written	Block writes digital output with a value of...
≥ 0.5	1
< 0.5	0

Scaling of Output to Input

I/O Module Output	Block Input Data Type	Scaling
TTL	Double	$< 0.5 = \text{TTL low}$ $\geq 0.5 = \text{TTL high}$

Block Parameters

Channel vector

Enter numbers between 1 and 32 to select the digital output lines used with this port. This driver allows the selection of individual digital output lines in arbitrary order. The number of elements defines the number of digital lines used.

For example, to use the first eight digital outputs, enter

```
[1,2,3,4,5,6,7,8]
```

Number the lines beginning with 1 even if this board manufacturer starts numbering the lines with 0.

Reset vector

The reset vector controls the behavior of the channel at model termination. Enter a scalar or a vector that is the same length as the channel vector. If you specify a scalar value, that setting is replicated over the channel vector. If you specify a value of 1, the corresponding channel is reset to the value specified in the initial value vector. If you specify a value of 0, the channel remains at the last value attained while the model was running.

Initial value vector

The initial value vector contains the initial values (0 or 1) of the output channels. Enter a scalar or a vector that is the same length as the channel vector. If you enter a scalar, that value is replicated as the initial value over the channel vector. The channels are set to these initial values between the time the model is downloaded and the time it is started.

Sample time

Enter the base sample time or a multiple of the base sample time (- 1 means sample time is inherited).

PCI slot (-1:autosearch)

If only one board of this type is in the target computer, enter - 1 to locate the board.

If two or more boards of this type are in the target computer, enter the bus number and the PCI slot number of the board associated with this driver block. Use the format [**BusNumber,SlotNumber**].

To determine the bus number and the PCI slot number, type:

```
tg = slrt;  
getPCIInfo(tg, 'installed')
```

External Websites

- www.ni.com

National Instruments PCI-6259 Incremental Encoder

Incremental Encoder block for PCI-6259, PCIe-6259, PXI-6259, and PXIe-6259 boards

Library

Simulink Real-Time Library for National Instruments

Scaling Input to Output

I/O Module Input	Block Output Data Type	Scaling
TTL level quadrature encoder signals	Double	counts

Block Parameters

Channel

From the list, choose 0 or 1 for the channel counter you want to use. For information on input for these counters, see the National Instruments M Series user manual. The pin associations are:

Counter	Channel 0	Channel 1
A	PFI 8 (Pin 37)	PFI 3 (Pin 42)
B	PFI 10 (Pin 45)	PFI 11 (Pin 46)
Z	PFI 9 (Pin 3)	PFI 4 (Pin 41)

Counting mode

From the list, select a counting mode:

Mode	Description
Quadrature Mode x1	Count on rising edges of the A signal
Quadrature Mode x2	Count on both rising and falling edges of the A signal

Mode	Description
Quadrature Mode x4	Count on both rising and falling edges of both A and B signals

The level of the opposite signal when an edge occurs determines the count direction. For example, a rising edge of A when B is high counts one way, while an edge of A when B is low counts the other. For more information, see the National Instruments M Series user manual.

Initial count

The initial count specifies the initial value for the counter. The block resets the count to this value under the following conditions:

- When the model starts
- When the following is true, which typically occurs once per revolution for a rotary encoder.
 - **Reload at index pulse** check box is selected
 - Index pulse (Z input) is true
 - The phases of A and B match the setting of **Index phase**

Reload at index pulse

Select this check box to reset the counter to the value of **Initial count** at each index pulse. The reset occurs when:

- The encoder outputs a high level on its index output
- The phases of A and B match the setting of **Index phase**

Index phase

If you have selected the **Reload at index pulse** check box, the **Index phase** parameter specifies the phase of the quadrature signals during which the count reloads with **Initial count**. Your choice of value primarily depends on the particular incremental encoder you use. From the list, select one:

- A low B low
- A low B high
- A high B low
- A high B high

To choose an **Index phase** for reset, use an oscilloscope, triggered on the index pulse, to observe the states of counters A and B. If your choice does not meet the encoder requirements, resets may be inconsistent.

Filter

You can apply a digital debouncing filter to the input pins before processing.

From the list, select a filter value to ignore pulses that are shorter than the filter time. The value of **NONE** indicates that the input is not filtered.

- None
- Minimum pulse width 125 nanoseconds
- Minimum pulse width 6.25 microseconds
- Minimum pulse width 1.25 milliseconds

Sample time

Enter the base sample time or a multiple of the base sample time (- 1 means sample time is inherited).

PCI slot (-1:autosearch)

If only one board of this type is in the target computer, enter - 1 to locate the board.

If two or more boards of this type are in the target computer, enter the bus number and the PCI slot number of the board associated with this driver block. Use the format **[BusNumber, SlotNumber]**.

To determine the bus number and the PCI slot number, type:

```
tg = slrt;  
getPCIInfo(tg, 'installed')
```

External Websites

- www.ni.com

National Instruments PCI-6259 PFI Digital Input

PFI Digital Input block for PCI-6259, PCIe-6259, PXI-6259, and PXIe-6259 boards

Library

Simulink Real-Time Library for National Instruments

Description

A model can have more than one PFI digital input block for a given physical board. If a model has more than one digital input block, it executes the blocks in the order that the Simulink software has determined.

The two counters and the PFI digital input and output blocks share the 16 PFI digital I/O lines. Follow these rules when using these blocks:

You can read a PFI bit with this digital input block when...	You cannot read a PFI bit with this digital input block when...
PWM measure block is using the bit	PWM generate block is using the bit
Incremental encoder block is using the bit	PFI digital output block is using the bit

Scaling of Input to Output

I/O Module Input	Block Output Data Type	Scaling
TTL	Double	TTL low ≥ 0.0 TTL high = 1.0

Block Parameters

PFI bit vector (0-15)

This block uses 0 based numbering to reflect the names of the bits described in the National Instruments M Series user manual.

Enter a vector that contains the bits you want to monitor. For example, to read bits PFI 0, PFI 5, and PFI 7, enter

```
[0, 5, 7]
```

Sample time

Enter the base sample time or a multiple of the base sample time (- 1 means sample time is inherited).

PCI slot (-1:autosearch)

If only one board of this type is in the target computer, enter - 1 to locate the board.

If two or more boards of this type are in the target computer, enter the bus number and the PCI slot number of the board associated with this driver block. Use the format **[BusNumber, SlotNumber]**.

To determine the bus number and the PCI slot number, type:

```
tg = slrt;  
getPCIInfo(tg, 'installed')
```

External Websites

- www.ni.com

National Instruments PCI-6259 PFI Digital Output

PFI Digital Output block for PCI-6259, PCIe-6259, PXI-6259, and PXIe-6259 boards

Library

Simulink Real-Time Library for National Instruments

Description

A model can have more than one PFI digital input block for a given physical board. If a model has more than one digital input block, it executes the blocks in the order that the Simulink software has determined.

The two counters and the PFI digital input and output blocks share the 16 PFI digital I/O lines. Follow these rules when using these blocks:

- Do not use a PFI bit as a digital output when the PDF digital input block is using the bit.
- Do not use a PFI bit as a digital output when the incremental encoder is using the bit.
- Do not use a PFI bit for digital output when the PWM generate block is using the bit.

Scaling of Output to Input

I/O Module Output	Block Input Data Type	Scaling
TTL	Double	< 0.5 = TTL low ≥ 0.5 = TTL high

Block Parameters

PFI bit vector (0-15)

This block uses 0 based numbering to reflect the names of the bits described in the National Instruments M Series user manual.

Enter a vector that contains the bits you want to control. For example, to write bits PFI 1, PFI 3, and PFI 9, enter

```
[1, 3, 9]
```

Reset vector

The reset vector controls the behavior of the channel at model termination. Enter a scalar or a vector that is the same length as the channel vector. If you specify a scalar value, that setting is replicated over the channel vector. If you specify a value of 1, the corresponding channel is reset to the value specified in the initial value vector. If you specify a value of 0, the channel remains at the last value attained while the model was running.

Initial value vector

The initial value vector contains the initial values (0 or 1) of the block outputs. Enter a scalar or a vector of values, one for each output. If you enter a scalar, the driver replicates that value over the output vector.

The block applies this value as follows:

- The model uses this value when you first download the model to the target computer.
- If you set **Reset vector** to 1, the block output is reset to this value when model execution stops. If the value is greater than 0.5, the block sets output to **HIGH**. If the value is less than or equal to 0.5, the block sets the output to **LOW**.

Sample time

Enter the base sample time or a multiple of the base sample time (-1 means sample time is inherited).

PCI slot (-1:autosearch)

If only one board of this type is in the target computer, enter -1 to locate the board.

If two or more boards of this type are in the target computer, enter the bus number and the PCI slot number of the board associated with this driver block. Use the format [**BusNumber**, **SlotNumber**].

To determine the bus number and the PCI slot number, type:

```
tg = slrt;
getPCIInfo(tg, 'installed')
```

External Websites

- www.ni.com

National Instruments PCI-6259 PWM Generate

PWM Generate block for PCI-6259, PCIe-6259, PXI-6259, and PXIe-6259 boards

Library

Simulink Real-Time Library for National Instruments

Description

Use this block to generate variable frequency and pulse width output.

The M Series boards have two 32-bit counters that you can use to generate pulse trains. Inputs are in counts of the 80 MHz reference frequency on the onboard clock.

- H input is the number of counts that the output is high.
- L input is the number of counts that the output is low.

If the H input goes to 0, the output stays low. If the L input goes to 0, the output stays high. If both are 0, the output goes low.

Block Parameters

Counter

From the list, select the counter, 0 or 1, that you want to use. The output for these counters is on the following pins:

Counter	Pin
0	PFI 12 (Pin 2)
1	PFI 13 (Pin 40)

Initial high count

Enter the number of counts the output is high between the time the Simulink engine calls the `mdlStart` routine for this block and the first time it calls `mdlOutputs`. This

length of time depends on the number of blocks in the model and the sorted order as determined by the Simulink software.

If you enter a value of 0, the output stays low until the first time the Simulink engine calls `mdlOutputs`.

Initial low count

Enter the number of counts the output is low between the time the Simulink engine calls the `mdlStart` routine for this block and the first time it calls `mdlOutputs`. This length of time depends on the number of blocks in the model and the sorted order as determined by the Simulink software. If you enter a value of 0, the output stays high until the first time the Simulink engine calls `mdlOutputs`, unless you have also set `H` to 0.

Arm input

Select this check box to add a third input port to the block.

- If the input connected to this port is greater than 0.5, the block arms the counter. Output then occurs.
- If the input connected to this port is less than or equal to 0.5, the block disarms the counter and the output goes to the level of the value in the **Disarm level** parameter.

Disarm level

From the list, select the disarm level **Disarm to LOW** or **Disarm to HIGH**. If the model disarms the block and the level of the value is **Arm input**, the output goes to the level you select here.

Stop level

From the list, select the stop level **Stop to LOW** or **Stop to HIGH**. When model execution stops, the output goes to the level you choose here.

Sample time

Enter the base sample time or a multiple of the base sample time (-1 means sample time is inherited).

PCI slot (-1:autosearch)

If only one board of this type is in the target computer, enter -1 to locate the board.

If two or more boards of this type are in the target computer, enter the bus number and the PCI slot number of the board associated with this driver block. Use the format **[BusNumber,SlotNumber]**.

To determine the bus number and the PCI slot number, type:

```
tg = slrt;  
getPCIInfo(tg, 'installed')
```

External Websites

- www.ni.com

National Instruments PCI-6259 PWM Measure

PWM Measure block for PCI-6259, PCIe-6259, PXI-6259, and PXIe-6259 boards

Library

Simulink Real-Time Library for National Instruments

Description

Use this block to measure the pulse width or the period of a signal.

To measure the pulse width of a signal, connect the signal to the gate, as follows:

Counter	Gate Pin
0	PFI 9 (Pin 3)
1	PFI 4 (Pin 41)

The input waveform must have fast rise and fall times and conform to TTL signal levels of [0,5] volts. Use external signal conditioning to achieve these levels. If you input a sine wave, the decision points are less definite and the measurement is noisy. In extreme cases, the gate can transition multiple times during a slow signal transition.

This block does not queue or buffer measurements. If the gate changes state, the driver holds the current count, overwriting the previous value.

This block returns the length of the last gate period before the block executes.

To compute the duty cycle percentage, use two counters. Because the period of a cycle is H counter + L counter, you can measure two of these counters and compute the third.

You cannot measure a 0 width pulse.

Block Parameters

Counter

From the list, select a counter, 0 or 1.

Trigger mode

From the list, select the gating mode to use:

Mode	Description
Width of Gate High	Returns the number of 80 MHz cycles that occur when a single cycle of the input is high.
Width of Gate Low	Returns the number of 80 MHz cycles that occur when a single cycle of the input is low.
Between Rising Edges	Returns the number of 80 MHz cycles that occur between rising edges of the input signal. This cycle is the full period of the input signal.
Between Falling Edges	Returns the number of 80 MHz cycles that occur between falling edges of the input signal. This cycle is the full period of the input signal.

If the input signal has both fast rise and fall edges, **Between Rising Edges** and **Between Falling Edges** return the same value. If the input is asymmetric, one of these options can give a better result than the other.

Filter

You can apply a digital debouncing filter to the input pins before processing.

From the list, select a filter value to ignore pulses that are shorter than the filter time. The block ignores pulses shorter than the chosen duration. The value of **None** indicates that the input is not filtered

- None
- Minimum pulse width 125 nanoseconds
- Minimum pulse width 6.25 microseconds
- Minimum pulse width 1.25 milliseconds

Sample time

Enter the base sample time or a multiple of the base sample time (- 1 means sample time is inherited).

PCI slot (-1:autosearch)

If only one board of this type is in the target computer, enter - 1 to locate the board.

If two or more boards of this type are in the target computer, enter the bus number and the PCI slot number of the board associated with this driver block. Use the format **[BusNumber,SlotNumber]**.

To determine the bus number and the PCI slot number, type:

```
tg = slrt;  
getPCIInfo(tg, 'installed')
```

External Websites

- www.ni.com

National Instruments PCI-6280

Support for PCI-6280 and PXI-6280 boards

Board

National Instruments PCI-6280, PXI-6280

General Description

The 6280 M-series boards are data acquisition I/O boards with up to 16 single-ended or 8 differential 18-bit analog inputs, 24 digital I/O lines, and two 32-bit 80 MHz counters.

The Simulink Real-Time block library supports the 6280 boards with these driver blocks:

- National Instruments PCI-6280 Analog Input
- National Instruments PCI-6280 Digital Input
- National Instruments PCI-6280 Digital Output
- National Instruments PCI-6280 Incremental Encoder
- National Instruments PCI-6280 PFI Digital Input
- National Instruments PCI-6280 PFI Digital Output
- National Instruments PCI-6280 PWM Generate
- National Instruments PCI-6280 PWM Measure

Board Characteristics

Board name	PCI-6280, PXI-6280
Manufacturer	National Instruments
Bus type	PCI, PXI (both use PCI version of blocks)
Multiple block instance support	A/D: No, Digital I/O: Yes
Multiple board support	Yes

External Websites

- www.ni.com

National Instruments PCI-6280 Analog Input

Analog Input block for PCI-6280 and PXI-6280 boards

Library

Simulink Real-Time Library for National Instruments

Scaling of Input to Output

I/O Module Input	Block Output Data Type	Scaling
Volts	Double	1

Block Parameters

Channel vector

Enter numbers between 1 and 16. This driver allows you to enter channel numbers in arbitrary order.

For example, to use the first, second, and fifth channels, enter

[1,2,5]

Number the lines beginning with 1 even if this board manufacturer starts numbering the lines with 0.

Range vector

Enter a range code for each of the channels in the channel vector. You can specify one value to replicate over the channel vector, or specify one for each channel. This driver allows each channel to be different. This board works only in bipolar mode.

The following table is a list of the ranges for this driver and the corresponding range codes.

Input Range (V)	Range Code
-10 to +10	10
-5 to +5	5

Input Range (V)	Range Code
-2 to +2	2
-1 to +1	1
-0.5 to +0.5	0.5
-0.2 to +0.2	0.2
-0.1 to +0.1	0.1

For example, if the first channel is -10 to +10 volts and the second and fifth channels are -1 to +1 volts, enter

[10,1,1]

Input coupling vector

Enter a coupling code for each of the channels in the channel vector. You can replicate one value over the channel vector, or specify one for each channel. This driver allows a different coupling for each channel.

The following table is a list of the couplings for this driver and the corresponding coupling codes.

Coupling	Coupling Code	Description
RSE	0	Analog input line connected to the positive input of the PGIA. Analog input ground (AIGND) internally connected to the negative input of the PGIA. See the National Instruments user manual.
NRSE	1	Analog input line connected to the positive input of the PGIA. Analog input sense (AISENSE) connected to the negative input of the PGIA. See the National Instruments user manual.
DIFF	2	First analog input line connected to the positive input of the PGIA. Second analog input line connected to the negative input of the PGIA. See the National Instruments user manual.

For example, if the first and second channels are single input and the fifth channel is a differential input, enter

[0,0,2]

National Instruments boards use a zero-based number scheme for differential mode channel pairs. Simulink Real-Time drivers use a one-based number scheme that adds a 1 to the I/O module number, as shown in the following table:

Zero-Based Channel Number		One-Based Channel Number	
+	-	+	-
0	8	1	9
1	9	2	10
2	10	3	11
3	11	4	12
4	12	5	13
5	13	6	14
6	14	7	15
7	15	8	16

The I/O module uses a second input 8 channels higher than the first channel as the negative input of the pair. In the example above, the I/O module would use the 13th channel as a differential input with the fifth channel.

If the module is set up for differential mode, you can read the data from either of the channels in the differential pair. For example, if you have a differential pair of 1 and 9, you can read the data from channel 1 or channel 9. However, you might want to read the lower channel number of the pair because it remains unchanged when you switch the input mode between single-ended and differential.

Scan interval

If **Channel vector** has more than one channel in it, enter the time between sampling different channels. Because execution waits for data to be available, this value increases the time to execute the block. If you enter a shorter time, you get the minimum 2e-6. If you enter a time smaller than this value, the time will still be 4e-6, which is the fastest this board can acquire data. See the National Instruments user manual for a discussion about settling time and the need to control the time between sampling different channels depending on the impedance of the signal source.

Sample time

Enter the base sample time or a multiple of the base sample time (- 1 means sample time is inherited).

PCI slot (-1:autosearch)

If only one board of this type is in the target computer, enter - 1 to locate the board.

If two or more boards of this type are in the target computer, enter the bus number and the PCI slot number of the board associated with this driver block. Use the format **[BusNumber,SlotNumber]**.

To determine the bus number and the PCI slot number, type:

```
tg = slrt;  
getPCIInfo(tg, 'installed')
```

External Websites

- www.ni.com

National Instruments PCI-6280 Digital Input

Digital Input block for PCI-6280 and PXI-6280 boards

Library

Simulink Real-Time Library for National Instruments

Note

Models can have multiple digital input blocks for one physical board. In this case, the Simulink Real-Time environment executes the blocks based on their sorted order as determined by the Simulink software.

Each board has one set of static digital I/O ports. You can independently configure each port to be input or output.

If a digital input block shares channels with a digital output block, the input block reads the last value written to the digital output block on the overlapping channels.

Scaling of Input to Output

I/O Module Input	Block Output Data Type	Scaling
TTL	Double	TTL low ≥ 0.0 TTL high = 1.0

Block Parameters

Channel vector

Enter numbers between 1 and 8 to select the digital input lines used with this port. This driver allows the selection of individual digital input lines in arbitrary order. The number of elements defines the number of digital lines used.

For example, to use the first eight digital inputs for one port, enter

[1,2,3,4,5,6,7,8]

Number the lines beginning with 1 even if this board manufacturer starts numbering the lines with 0.

Sample time

Enter the base sample time or a multiple of the base sample time (- 1 means sample time is inherited).

PCI slot (-1:autosearch)

If only one board of this type is in the target computer, enter - 1 to locate the board.

If two or more boards of this type are in the target computer, enter the bus number and the PCI slot number of the board associated with this driver block. Use the format **[BusNumber,SlotNumber]**.

To determine the bus number and the PCI slot number, type:

```
tg = slrt;  
getPCIInfo(tg, 'installed')
```

External Websites

- www.ni.com

National Instruments PCI-6280 Digital Output

Digital Output block for PCI-6280 and PXI-6280 boards

Library

Simulink Real-Time Library for National Instruments

Note

Models can have multiple digital output blocks for one physical board. In this case, the Simulink Real-Time environment executes the blocks based on their sorted order as determined by the Simulink software.

Each board has one set of digital I/O ports. You can independently configure each port to be input or output.

If a digital input block shares channels with a digital output block, the input block reads the last value written to the digital output block on the overlapping channels.

The block compares the value written to each port with 0.5.

Value written	Block writes digital output with a value of...
≥ 0.5	1
< 0.5	0

Scaling of Output to Input

I/O Module Output	Block Input Data Type	Scaling
TTL	Double	< 0.5 = TTL low ≥ 0.5 = TTL high

Block Parameters

Channel vector

Enter numbers between 1 and 8 to select the digital output lines used with this port. This driver allows the selection of individual digital output lines in arbitrary order. The number of elements defines the number of digital lines used.

For example, to use the first eight digital outputs, enter

```
[1,2,3,4,5,6,7,8]
```

Number the lines beginning with 1 even if this board manufacturer starts numbering the lines with 0.

Reset vector

The reset vector controls the behavior of the channel at model termination. Enter a scalar or a vector that is the same length as the channel vector. If you specify a scalar value, that setting is replicated over the channel vector. If you specify a value of 1, the corresponding channel is reset to the value specified in the initial value vector. If you specify a value of 0, the channel remains at the last value attained while the model was running.

Initial value vector

The initial value vector contains the initial values (0 or 1) of the output channels. Enter a scalar or a vector that is the same length as the channel vector. If you enter a scalar, that value is replicated as the initial value over the channel vector. The channels are set to these initial values between the time the model is downloaded and the time it is started.

Sample time

Enter the base sample time or a multiple of the base sample time (-1 means sample time is inherited).

PCI slot (-1:autosearch)

If only one board of this type is in the target computer, enter -1 to locate the board.

If two or more boards of this type are in the target computer, enter the bus number and the PCI slot number of the board associated with this driver block. Use the format [**BusNumber**,**SlotNumber**].

To determine the bus number and the PCI slot number, type:

```
tg = slrt;  
getPCIInfo(tg, 'installed')
```

External Websites

- www.ni.com

National Instruments PCI-6280 Incremental Encoder

Incremental Encoder block for PCI-6280 and PXI-6280 boards

Library

Simulink Real-Time Library for National Instruments

Scaling Input to Output

I/O Module Input	Block Output Data Type	Scaling
TTL level quadrature encoder signals	Double	counts

Block Parameters

Channel

From the list, choose 0 or 1 for the channel counter you want to use. For information on input for these counters, see the National Instruments M Series user manual. The pin associations are:

Counter	Channel 0	Channel 1
A	PFI 8 (Pin 37)	PFI 3 (Pin 42)
B	PFI 10 (Pin 45)	PFI 11 (Pin 46)
Z	PFI 9 (Pin 3)	PFI 4 (Pin 41)

Counting mode

From the list, select a counting mode:

Mode	Description
Quadrature Mode x1	Count on rising edges of the A signal
Quadrature Mode x2	Count on both rising and falling edges of the A signal

Mode	Description
Quadrature Mode x4	Count on both rising and falling edges of both A and B signals

The level of the opposite signal when an edge occurs determines the count direction. For example, a rising edge of A when B is high counts one way, while an edge of A when B is low counts the other. For more information, see the National Instruments M Series user manual.

Initial count

The initial count specifies the initial value for the counter. The block resets the count to this value under the following conditions:

- When the model starts
- When the following is true, which typically occurs once per revolution for a rotary encoder.
 - **Reload at index pulse** check box is selected
 - Index pulse (Z input) is true
 - The phases of A and B match the setting of **Index phase**

Reload at index pulse

Select this check box to reset the counter to the value of **Initial count** at each index pulse. The reset occurs when:

- The encoder outputs a high level on its index output
- The phases of A and B match the setting of **Index phase**

Index phase

If you have selected the **Reload at index pulse** check box, the **Index phase** parameter specifies the phase of the quadrature signals during which the count reloads with **Initial count**. Your choice of value primarily depends on the particular incremental encoder you use. From the list, select one:

- A low B low
- A low B high
- A high B low
- A high B high

To choose an **Index phase** for reset, use an oscilloscope, triggered on the index pulse, to observe the states of counters A and B. If your choice does not meet the encoder requirements, resets may be inconsistent.

Filter

You can apply a digital debouncing filter to the input pins before processing.

From the list, select a filter value to ignore pulses that are shorter than the filter time. The value of **NONE** indicates that the input is not filtered.

- None
- Minimum pulse width 125 nanoseconds
- Minimum pulse width 6.25 microseconds
- Minimum pulse width 1.25 milliseconds

Sample time

Enter the base sample time or a multiple of the base sample time (- 1 means sample time is inherited).

PCI slot (-1:autosearch)

If only one board of this type is in the target computer, enter - 1 to locate the board.

If two or more boards of this type are in the target computer, enter the bus number and the PCI slot number of the board associated with this driver block. Use the format **[BusNumber, SlotNumber]**.

To determine the bus number and the PCI slot number, type:

```
tg = slrt;  
getPCIInfo(tg, 'installed')
```

External Websites

- www.ni.com

National Instruments PCI-6280 PWM Generate

PWM Generate block for PCI-6280 and PXI-6280 boards

Library

Simulink Real-Time Library for National Instruments

Description

Use this block to generate variable frequency and pulse width output.

The M Series boards have two 32-bit counters that you can use to generate pulse trains. Inputs are in counts of the 80 MHz reference frequency on the onboard clock.

- H input is the number of counts that the output is high.
- L input is the number of counts that the output is low.

If the H input goes to 0, the output stays low. If the L input goes to 0, the output stays high. If both are 0, the output goes low.

Block Parameters

Counter

From the list, select the counter, 0 or 1, that you want to use. The output for these counters is on the following pins:

Counter	Pin
0	PFI 12 (Pin 2)
1	PFI 13 (Pin 40)

Initial high count

Enter the number of counts the output is high between the time the Simulink engine calls the `mdlStart` routine for this block and the first time it calls `mdlOutputs`. This

length of time depends on the number of blocks in the model and the sorted order as determined by the Simulink software.

If you enter a value of 0, the output stays low until the first time the Simulink engine calls `mdlOutputs`.

Initial low count

Enter the number of counts the output is low between the time the Simulink engine calls the `mdlStart` routine for this block and the first time it calls `mdlOutputs`. This length of time depends on the number of blocks in the model and the sorted order as determined by the Simulink software. If you enter a value of 0, the output stays high until the first time the Simulink engine calls `mdlOutputs`, unless you have also set `H` to 0.

Arm input

Select this check box to add a third input port to the block.

- If the input connected to this port is greater than 0.5, the block arms the counter. Output then occurs.
- If the input connected to this port is less than or equal to 0.5, the block disarms the counter and the output goes to the level of the value in the **Disarm level** parameter.

Disarm level

From the list, select the disarm level **Disarm to LOW** or **Disarm to HIGH**. If the model disarms the block and the level of the value is **Arm input**, the output goes to the level you select here.

Stop level

From the list, select the stop level **Stop to LOW** or **Stop to HIGH**. When model execution stops, the output goes to the level you choose here.

Sample time

Enter the base sample time or a multiple of the base sample time (-1 means sample time is inherited).

PCI slot (-1:autosearch)

If only one board of this type is in the target computer, enter -1 to locate the board.

If two or more boards of this type are in the target computer, enter the bus number and the PCI slot number of the board associated with this driver block. Use the format **[BusNumber, SlotNumber]**.

To determine the bus number and the PCI slot number, type:

```
tg = slrt;  
getPCIInfo(tg, 'installed')
```

External Websites

- www.ni.com

National Instruments PCI-6280 PFI Digital Input

PFI Digital Input block for PCI-6280 and PXI-6280 boards

Library

Simulink Real-Time Library for National Instruments

Description

A model can have more than one PFI digital input block for a given physical board. If a model has more than one digital input block, it executes the blocks in the order that the Simulink software has determined.

The two counters and the PFI digital input and output blocks share the 16 PFI digital I/O lines. Follow these rules when using these blocks:

You can read a PFI bit with this digital input block when...	You cannot read a PFI bit with this digital input block when...
PWM measure block is using the bit	PWM generate block is using the bit
Incremental encoder block is using the bit	PFI digital output block is using the bit

Scaling of Input to Output

I/O Module Input	Block Output Data Type	Scaling
TTL	Double	TTL low ≥ 0.0 TTL high = 1.0

Block Parameters

PFI bit vector (0-15)

This block uses 0 based numbering to reflect the names of the bits described in the National Instruments M Series user manual.

Enter a vector that contains the bits you want to monitor. For example, to read bits PFI 0, PFI 5, and PFI 7, enter

```
[0, 5, 7]
```

Sample time

Enter the base sample time or a multiple of the base sample time (- 1 means sample time is inherited).

PCI slot (-1:autosearch)

If only one board of this type is in the target computer, enter - 1 to locate the board.

If two or more boards of this type are in the target computer, enter the bus number and the PCI slot number of the board associated with this driver block. Use the format **[BusNumber, SlotNumber]**.

To determine the bus number and the PCI slot number, type:

```
tg = slrt;  
getPCIInfo(tg, 'installed')
```

External Websites

- www.ni.com

National Instruments PCI-6280 PFI Digital Output

PFI Digital Output block for PCI-6280 and PXI-6280 boards

Library

Simulink Real-Time Library for National Instruments

Description

A model can have more than one PFI digital input block for a given physical board. If a model has more than one digital input block, it executes the blocks in the order that the Simulink software has determined.

The two counters and the PFI digital input and output blocks share the 16 PFI digital I/O lines. Follow these rules when using these blocks:

- Do not use a PFI bit as a digital output when the PDF digital input block is using the bit.
- Do not use a PFI bit as a digital output when the incremental encoder is using the bit.
- Do not use a PFI bit for digital output when the PWM generate block is using the bit.

Scaling of Output to Input

I/O Module Output	Block Input Data Type	Scaling
TTL	Double	< 0.5 = TTL low ≥ 0.5 = TTL high

Block Parameters

PFI bit vector (0-15)

This block uses 0 based numbering to reflect the names of the bits described in the National Instruments M Series user manual.

Enter a vector that contains the bits you want to control. For example, to write bits PFI 1, PFI 3, and PFI 9, enter

```
[1, 3, 9]
```

Reset vector

The reset vector controls the behavior of the channel at model termination. Enter a scalar or a vector that is the same length as the channel vector. If you specify a scalar value, that setting is replicated over the channel vector. If you specify a value of 1, the corresponding channel is reset to the value specified in the initial value vector. If you specify a value of 0, the channel remains at the last value attained while the model was running.

Initial value vector

The initial value vector contains the initial values (0 or 1) of the block outputs. Enter a scalar or a vector of values, one for each output. If you enter a scalar, the driver replicates that value over the output vector.

The block applies this value as follows:

- The model uses this value when you first download the model to the target computer.
- If you set **Reset vector** to 1, the block output is reset to this value when model execution stops. If the value is greater than 0.5, the block sets output to **HIGH**. If the value is less than or equal to 0.5, the block sets the output to **LOW**.

Sample time

Enter the base sample time or a multiple of the base sample time (-1 means sample time is inherited).

PCI slot (-1:autosearch)

If only one board of this type is in the target computer, enter -1 to locate the board.

If two or more boards of this type are in the target computer, enter the bus number and the PCI slot number of the board associated with this driver block. Use the format [**BusNumber**, **SlotNumber**].

To determine the bus number and the PCI slot number, type:

```
tg = slrt;
getPCIInfo(tg, 'installed')
```

External Websites

- www.ni.com

National Instruments PCI-6280 PWM Measure

PWM Measure block for PCI-6280 and PXI-6280 boards

Library

Simulink Real-Time Library for National Instruments

Description

Use this block to measure the pulse width or the period of a signal.

To measure the pulse width of a signal, connect the signal to the gate, as follows:

Counter	Gate Pin
0	PFI 9 (Pin 3)
1	PFI 4 (Pin 41)

The input waveform must have fast rise and fall times and conform to TTL signal levels of [0,5] volts. Use external signal conditioning to achieve these levels. If you input a sine wave, the decision points are less definite and the measurement is noisy. In extreme cases, the gate can transition multiple times during a slow signal transition.

This block does not queue or buffer measurements. If the gate changes state, the driver holds the current count, overwriting the previous value.

This block returns the length of the last gate period before the block executes.

To compute the duty cycle percentage, use two counters. Because the period of a cycle is H counter + L counter, you can measure two of these counters and compute the third.

You cannot measure a 0 width pulse.

Block Parameters

Counter

From the list, select a counter, 0 or 1.

Trigger mode

From the list, select the trigger mode to use:

Mode	Description
Width of Gate High	Returns the number of 80 MHz cycles that occur when a single cycle of the input is high.
Width of Gate Low	Returns the number of 80 MHz cycles that occur when a single cycle of the input is low.
Between Rising Edges	Returns the number of 80 MHz cycles that occur between rising edges of the input signal. This cycle is the full period of the input signal.
Between Falling Edges	Returns the number of 80 MHz cycles that occur between falling edges of the input signal. This cycle is the full period of the input signal.

If the input signal has both fast rise and fall edges, **Between Rising Edges** and **Between Falling Edges** return the same value. If the input is asymmetric, one of these options can give a better result than the other.

Filter

You can apply a digital debouncing filter to the input pins before processing.

From the list, select a filter value to ignore pulses that are shorter than the filter time. The block ignores pulses shorter than the chosen duration. The value of **None** indicates that the input is not filtered

- None
- Minimum pulse width 125 nanoseconds
- Minimum pulse width 6.25 microseconds
- Minimum pulse width 1.25 milliseconds

Sample time

Enter the base sample time or a multiple of the base sample time (- 1 means sample time is inherited).

PCI slot (-1:autosearch)

If only one board of this type is in the target computer, enter - 1 to locate the board.

If two or more boards of this type are in the target computer, enter the bus number and the PCI slot number of the board associated with this driver block. Use the format **[BusNumber,SlotNumber]**.

To determine the bus number and the PCI slot number, type:

```
tg = slrt;  
getPCIInfo(tg, 'installed')
```

External Websites

- www.ni.com

National Instruments PCI-6281

Support for PCI-6281 and PXI-6281 boards

Board

National Instruments PCI-6281, PXI-6281

General Description

The 6281 M-series boards are data acquisition I/O boards with up to 16 single-ended or 8 differential 18-bit analog inputs, two 16-bit analog outputs, 24 digital I/O lines, and two 32-bit 80 MHz counters.

The Simulink Real-Time block library supports the 6281 boards with these driver blocks:

- National Instruments PCI-6281 Analog Input
- National Instruments PCI-6281 Analog Output
- National Instruments PCI-6281 Digital Input
- National Instruments PCI-6281 Digital Output
- National Instruments PCI-6281 Incremental Encoder
- National Instruments PCI-6281 PFI Digital Input
- National Instruments PCI-6281 PFI Digital Output
- National Instruments PCI-6281 PWM Generate
- National Instruments PCI-6281 PWM Measure

The Simulink Real-Time block library supports this board with these driver blocks:

Board Characteristics

Board name	PCI-6281, PXI-6281
Manufacturer	National Instruments
Bus type	PCI, PXI (both use PCI version of blocks)

Multiple block instance support
Multiple board support

A/D: No, D/A: No, Digital I/O: Yes
Yes

External Websites

- www.ni.com

National Instruments PCI-6281 Analog Input

Analog Input block for PCI-6281 and PXI-6281 boards

Library

Simulink Real-Time Library for National Instruments

Scaling of Input to Output

I/O Module Input	Block Output Data Type	Scaling
Volts	Double	1

Block Parameters

Channel vector

Enter numbers between 1 and 16. This driver allows you to enter channel numbers in arbitrary order.

For example, to use the first, second, and fifth channels, enter

[1,2,5]

Number the lines beginning with 1 even if this board manufacturer starts numbering the lines with 0.

Range vector

Enter a range code for each of the channels in the channel vector. You can specify one value to replicate over the channel vector, or specify one for each channel. This driver allows each channel to be different. This board works only in bipolar mode.

The following table is a list of the ranges for this driver and the corresponding range codes.

Input Range (V)	Range Code
-10 to +10	10
-5 to +5	5

Input Range (V)	Range Code
-2 to +2	2
-1 to +1	1
-0.5 to +0.5	0.5
-0.2 to +0.2	0.2
-0.1 to +0.1	0.1

For example, if the first channel is -10 to +10 volts and the second and fifth channels are -1 to +1 volts, enter

[10,1,1]

Input coupling vector

Enter a coupling code for each of the channels in the channel vector. You can replicate one value over the channel vector, or specify one for each channel. This driver allows a different coupling for each channel.

The following table is a list of the couplings for this driver and the corresponding coupling codes.

Coupling	Coupling Code	Description
RSE	0	Analog input line connected to the positive input of the PGIA. Analog input ground (AIGND) internally connected to the negative input of the PGIA. See the National Instruments user manual.
NRSE	1	Analog input line connected to the positive input of the PGIA. Analog input sense (AISENSE) connected to the negative input of the PGIA. See the National Instruments user manual.
DIFF	2	First analog input line connected to the positive input of the PGIA. Second analog input line connected to the negative input of the PGIA. See the National Instruments user manual.

For example, if the first and second channels are single input and the fifth channel is a differential input, enter

[0,0,2]

National Instruments boards use a zero-based number scheme for differential mode channel pairs. Simulink Real-Time drivers use a one-based number scheme that adds a 1 to the I/O module number, as shown in the following table:

Zero-Based Channel Number		One-Based Channel Number	
+	-	+	-
0	8	1	9
1	9	2	10
2	10	3	11
3	11	4	12
4	12	5	13
5	13	6	14
6	14	7	15
7	15	8	16

The I/O module uses a second input 8 channels higher than the first channel as the negative input of the pair. In the example above, the I/O module would use the 13th channel as a differential input with the fifth channel.

If the module is set up for differential mode, you can read the data from either of the channels in the differential pair. For example, if you have a differential pair of 1 and 9, you can read the data from channel 1 or channel 9. However, you might want to read the lower channel number of the pair because it remains unchanged when you switch the input mode between single-ended and differential.

Scan interval

If **Channel vector** has more than one channel in it, enter the time between sampling different channels. Because execution waits for data to be available, this value increases the time to execute the block. If you enter a shorter time, you get the minimum 2e-6. If you enter a time smaller than this value, the time will still be 4e-6, which is the fastest this board can acquire data. See the National Instruments user manual for a discussion about settling time and the need to control the time between sampling different channels depending on the impedance of the signal source.

Sample time

Enter the base sample time or a multiple of the base sample time (-1 means sample time is inherited).

PCI slot (-1:autosearch)

If only one board of this type is in the target computer, enter - 1 to locate the board.

If two or more boards of this type are in the target computer, enter the bus number and the PCI slot number of the board associated with this driver block. Use the format **[BusNumber,SlotNumber]**.

To determine the bus number and the PCI slot number, type:

```
tg = slrt;  
getPCIInfo(tg, 'installed')
```

External Websites

- www.ni.com

National Instruments PCI-6281 Analog Output

Analog Output block for PCI-6281 and PXI-6281 boards

Library

Simulink Real-Time Library for National Instruments

Scaling of Output to Input

I/O Module Output	Block Input Data Type	Scaling
Volts	Double	1

Block Parameters

Channel vector

Enter 1 or 2. This driver allows the selection of individual D/A channels in arbitrary order. The number of elements defines the number of D/A channels used. For example, to use both of the analog output channels, enter

[1,2]

Number the channels begin with 1 even if this board manufacturer starts numbering the channels with 0.

Range vector

Enter a range code for each of the channels in the channel vector. The range vector must be the same length as the channel vector. This board allows the range of each channel to be different.

The following table is a list of the ranges for this driver and the corresponding range codes.

Input Range (V)	Range Code
-10 to +10	-10
-5 to +5	-5

Input Range (V)	Range Code
$V_{ref} \times sig$, where $-1 \leq sig \leq +1$	APFIO

For example, if the first channel is -10 to +10 volts and the second channel is -5 to +5 volts, enter

[10,5]

Reset vector

The reset vector controls the behavior of the channel at model termination. Enter a scalar or a vector that is the same length as the channel vector. If you specify a scalar value, that setting is replicated over the channel vector. If you specify a value of 1, the corresponding channel is reset to the value specified in the initial value vector. If you specify a value of 0, the channel remains at the last value attained while the model was running.

Initial value vector

The initial value vector contains the initial voltage values for the output channels. Enter a scalar or a vector that is the same length as the channel vector. If you specify a scalar value, that value is replicated as the initial value over the channel vector. The channels are set to the initial values between the time the model is downloaded and the time it is started.

Sample time

Enter the base sample time or a multiple of the base sample time (-1 means sample time is inherited).

PCI slot (-1:autosearch)

If only one board of this type is in the target computer, enter -1 to locate the board.

If two or more boards of this type are in the target computer, enter the bus number and the PCI slot number of the board associated with this driver block. Use the format [**BusNumber**, **SlotNumber**].

To determine the bus number and the PCI slot number, type:

```
tg = slrt;
getPCIInfo(tg, 'installed')
```

External Websites

- www.ni.com

National Instruments PCI-6281 Digital Input

Digital Input block for PCI-6281 and PXI-6281 boards

Library

Simulink Real-Time Library for National Instruments

Note

Models can have multiple digital input blocks for one physical board. In this case, the Simulink Real-Time environment executes the blocks based on their sorted order as determined by the Simulink software.

Each board has one set of static digital I/O ports. You can independently configure each port to be input or output.

If a digital input block shares channels with a digital output block, the input block reads the last value written to the digital output block on the overlapping channels.

Scaling of Input to Output

I/O Module Input	Block Output Data Type	Scaling
TTL	Double	TTL low ≥ 0.0 TTL high = 1.0

Block Parameters

Channel vector

Enter numbers between 1 and 8 to select the digital input lines used with this port. This driver allows the selection of individual digital input lines in arbitrary order. The number of elements defines the number of digital lines used.

For example, to use the first eight digital inputs for one port, enter

[1,2,3,4,5,6,7,8]

Number the lines beginning with 1 even if this board manufacturer starts numbering the lines with 0.

Sample time

Enter the base sample time or a multiple of the base sample time (- 1 means sample time is inherited).

PCI slot (-1:autosearch)

If only one board of this type is in the target computer, enter - 1 to locate the board.

If two or more boards of this type are in the target computer, enter the bus number and the PCI slot number of the board associated with this driver block. Use the format **[BusNumber,SlotNumber]**.

To determine the bus number and the PCI slot number, type:

```
tg = slrt;  
getPCIInfo(tg, 'installed')
```

External Websites

- www.ni.com

National Instruments PCI-6281 Digital Output

Digital Output block for PCI-6281 and PXI-6281 boards

Library

Simulink Real-Time Library for National Instruments

Note

Models can have multiple digital output blocks for one physical board. In this case, the Simulink Real-Time environment executes the blocks based on their sorted order as determined by the Simulink software.

Each board has one set of digital I/O ports. You can independently configure each port to be input or output.

If a digital input block shares channels with a digital output block, the input block reads the last value written to the digital output block on the overlapping channels.

The block compares the value written to each port with 0.5.

Value written	Block writes digital output with a value of...
≥ 0.5	1
< 0.5	0

Scaling of Output to Input

I/O Module Output	Block Input Data Type	Scaling
TTL	Double	$< 0.5 = \text{TTL low}$ $\geq 0.5 = \text{TTL high}$

Block Parameters

Channel vector

Enter numbers between 1 and 8 to select the digital output lines used with this port. This driver allows the selection of individual digital output lines in arbitrary order. The number of elements defines the number of digital lines used.

For example, to use the first eight digital outputs, enter

```
[1,2,3,4,5,6,7,8]
```

Number the lines beginning with 1 even if this board manufacturer starts numbering the lines with 0.

Reset vector

The reset vector controls the behavior of the channel at model termination. Enter a scalar or a vector that is the same length as the channel vector. If you specify a scalar value, that setting is replicated over the channel vector. If you specify a value of 1, the corresponding channel is reset to the value specified in the initial value vector. If you specify a value of 0, the channel remains at the last value attained while the model was running.

Initial value vector

The initial value vector contains the initial values (0 or 1) of the output channels. Enter a scalar or a vector that is the same length as the channel vector. If you enter a scalar, that value is replicated as the initial value over the channel vector. The channels are set to these initial values between the time the model is downloaded and the time it is started.

Sample time

Enter the base sample time or a multiple of the base sample time (- 1 means sample time is inherited).

PCI slot (-1:autosearch)

If only one board of this type is in the target computer, enter - 1 to locate the board.

If two or more boards of this type are in the target computer, enter the bus number and the PCI slot number of the board associated with this driver block. Use the format **[BusNumber,SlotNumber]**.

To determine the bus number and the PCI slot number, type:

```
tg = slrt;  
getPCIInfo(tg, 'installed')
```

External Websites

- www.ni.com

National Instruments PCI-6281 Incremental Encoder

Incremental Encoder block for PCI-6281 and PXI-6281 boards

Library

Simulink Real-Time Library for National Instruments

Scaling Input to Output

I/O Module Input	Block Output Data Type	Scaling
TTL level quadrature encoder signals	Double	counts

Block Parameters

Channel

From the list, choose 0 or 1 for the channel counter you want to use. For information on input for these counters, see the National Instruments M Series user manual. The pin associations are:

Counter	Channel 0	Channel 1
A	PFI 8 (Pin 37)	PFI 3 (Pin 42)
B	PFI 10 (Pin 45)	PFI 11 (Pin 46)
Z	PFI 9 (Pin 3)	PFI 4 (Pin 41)

Counting mode

From the list, select a counting mode:

Mode	Description
Quadrature Mode x1	Count on rising edges of the A signal
Quadrature Mode x2	Count on both rising and falling edges of the A signal

Mode	Description
Quadrature Mode x4	Count on both rising and falling edges of both A and B signals

The level of the opposite signal when an edge occurs determines the count direction. For example, a rising edge of A when B is high counts one way, while an edge of A when B is low counts the other. For more information, see the National Instruments M Series user manual.

Initial count

The initial count specifies the initial value for the counter. The block resets the count to this value under the following conditions:

- When the model starts
- When the following is true, which typically occurs once per revolution for a rotary encoder.
 - **Reload at index pulse** check box is selected
 - Index pulse (Z input) is true
 - The phases of A and B match the setting of **Index phase**

Reload at index pulse

Select this check box to reset the counter to the value of **Initial count** at each index pulse. The reset occurs when:

- The encoder outputs a high level on its index output
- The phases of A and B match the setting of **Index phase**

Index phase

If you have selected the **Reload at index pulse** check box, the **Index phase** parameter specifies the phase of the quadrature signals during which the count reloads with **Initial count**. Your choice of value primarily depends on the particular incremental encoder you use. From the list, select one:

- A low B low
- A low B high
- A high B low
- A high B high

To choose an **Index phase** for reset, use an oscilloscope, triggered on the index pulse, to observe the states of counters A and B. If your choice does not meet the encoder requirements, resets may be inconsistent.

Filter

You can apply a digital debouncing filter to the input pins before processing.

From the list, select a filter value to ignore pulses that are shorter than the filter time. The value of **NONE** indicates that the input is not filtered.

- None
- Minimum pulse width 125 nanoseconds
- Minimum pulse width 6.25 microseconds
- Minimum pulse width 1.25 milliseconds

Sample time

Enter the base sample time or a multiple of the base sample time (- 1 means sample time is inherited).

PCI slot (-1:autosearch)

If only one board of this type is in the target computer, enter - 1 to locate the board.

If two or more boards of this type are in the target computer, enter the bus number and the PCI slot number of the board associated with this driver block. Use the format **[BusNumber, SlotNumber]**.

To determine the bus number and the PCI slot number, type:

```
tg = slrt;  
getPCIInfo(tg, 'installed')
```

External Websites

- www.ni.com

National Instruments PCI-6281 PFI Digital Input

PFI Digital Input block for PCI-6281 and PXI-6281 boards

Library

Simulink Real-Time Library for National Instruments

Description

A model can have more than one PFI digital input block for a given physical board. If a model has more than one digital input block, it executes the blocks in the order that the Simulink software has determined.

The two counters and the PFI digital input and output blocks share the 16 PFI digital I/O lines. Follow these rules when using these blocks:

You can read a PFI bit with this digital input block when...	You cannot read a PFI bit with this digital input block when...
PWM measure block is using the bit	PWM generate block is using the bit
Incremental encoder block is using the bit	PFI digital output block is using the bit

Scaling of Input to Output

I/O Module Input	Block Output Data Type	Scaling
TTL	Double	TTL low ≥ 0.0 TTL high = 1.0

Block Parameters

PFI bit vector (0-15)

This block uses 0 based numbering to reflect the names of the bits described in the National Instruments M Series user manual.

Enter a vector that contains the bits you want to monitor. For example, to read bits PFI 0, PFI 5, and PFI 7, enter

```
[0, 5, 7]
```

Sample time

Enter the base sample time or a multiple of the base sample time (- 1 means sample time is inherited).

PCI slot (-1:autosearch)

If only one board of this type is in the target computer, enter - 1 to locate the board.

If two or more boards of this type are in the target computer, enter the bus number and the PCI slot number of the board associated with this driver block. Use the format **[BusNumber, SlotNumber]**.

To determine the bus number and the PCI slot number, type:

```
tg = slrt;  
getPCIInfo(tg, 'installed')
```

External Websites

- www.ni.com

National Instruments PCI-6281 PFI Digital Output

PFI Digital Output block for PCI-6281 and PXI-6281 boards

Library

Simulink Real-Time Library for National Instruments

Description

A model can have more than one PFI digital input block for a given physical board. If a model has more than one digital input block, it executes the blocks in the order that the Simulink software has determined.

The two counters and the PFI digital input and output blocks share the 16 PFI digital I/O lines. Follow these rules when using these blocks:

- Do not use a PFI bit as a digital output when the PDF digital input block is using the bit.
- Do not use a PFI bit as a digital output when the incremental encoder is using the bit.
- Do not use a PFI bit for digital output when the PWM generate block is using the bit.

Scaling of Output to Input

I/O Module Output	Block Input Data Type	Scaling
TTL	Double	< 0.5 = TTL low ≥ 0.5 = TTL high

Block Parameters

PFI bit vector (0-15)

This block uses 0 based numbering to reflect the names of the bits described in the National Instruments M Series user manual.

Enter a vector that contains the bits you want to control. For example, to write bits PFI 1, PFI 3, and PFI 9, enter

```
[1, 3, 9]
```

Reset vector

The reset vector controls the behavior of the channel at model termination. Enter a scalar or a vector that is the same length as the channel vector. If you specify a scalar value, that setting is replicated over the channel vector. If you specify a value of 1, the corresponding channel is reset to the value specified in the initial value vector. If you specify a value of 0, the channel remains at the last value attained while the model was running.

Initial value vector

The initial value vector contains the initial values (0 or 1) of the block outputs. Enter a scalar or a vector of values, one for each output. If you enter a scalar, the driver replicates that value over the output vector.

The block applies this value as follows:

- The model uses this value when you first download the model to the target computer.
- If you set **Reset vector** to 1, the block output is reset to this value when model execution stops. If the value is greater than 0.5, the block sets output to **HIGH**. If the value is less than or equal to 0.5, the block sets the output to **LOW**.

Sample time

Enter the base sample time or a multiple of the base sample time (-1 means sample time is inherited).

PCI slot (-1:autosearch)

If only one board of this type is in the target computer, enter -1 to locate the board.

If two or more boards of this type are in the target computer, enter the bus number and the PCI slot number of the board associated with this driver block. Use the format [**BusNumber**, **SlotNumber**].

To determine the bus number and the PCI slot number, type:

```
tg = slrt;
getPCIInfo(tg, 'installed')
```

External Websites

- www.ni.com

National Instruments PCI-6281 PWM Generate

PWM Generate block for PCI-6281 and PXI-6281 boards

Library

Simulink Real-Time Library for National Instruments

Description

Use this block to generate variable frequency and pulse width output.

The M Series boards have two 32-bit counters that you can use to generate pulse trains. Inputs are in counts of the 80 MHz reference frequency on the onboard clock.

- H input is the number of counts that the output is high.
- L input is the number of counts that the output is low.

If the H input goes to 0, the output stays low. If the L input goes to 0, the output stays high. If both are 0, the output goes low.

Block Parameters

Counter

From the list, select the counter, 0 or 1, that you want to use. The output for these counters is on the following pins:

Counter	Pin
0	PFI 12 (Pin 2)
1	PFI 13 (Pin 40)

Initial high count

Enter the number of counts the output is high between the time the Simulink engine calls the `mdlStart` routine for this block and the first time it calls `mdlOutputs`. This

length of time depends on the number of blocks in the model and the sorted order as determined by the Simulink software.

If you enter a value of 0, the output stays low until the first time the Simulink engine calls `mdlOutputs`.

Initial low count

Enter the number of counts the output is low between the time the Simulink engine calls the `mdlStart` routine for this block and the first time it calls `mdlOutputs`. This length of time depends on the number of blocks in the model and the sorted order as determined by the Simulink software. If you enter a value of 0, the output stays high until the first time the Simulink engine calls `mdlOutputs`, unless you have also set `H` to 0.

Arm input

Select this check box to add a third input port to the block.

- If the input connected to this port is greater than 0.5, the block arms the counter. Output then occurs.
- If the input connected to this port is less than or equal to 0.5, the block disarms the counter and the output goes to the level of the value in the **Disarm level** parameter.

Disarm level

From the list, select the disarm level **Disarm to LOW** or **Disarm to HIGH**. If the model disarms the block and the level of the value is **Arm input**, the output goes to the level you select here.

Stop level

From the list, select the stop level **Stop to LOW** or **Stop to HIGH**. When model execution stops, the output goes to the level you choose here.

Sample time

Enter the base sample time or a multiple of the base sample time (-1 means sample time is inherited).

PCI slot (-1:autosearch)

If only one board of this type is in the target computer, enter -1 to locate the board.

If two or more boards of this type are in the target computer, enter the bus number and the PCI slot number of the board associated with this driver block. Use the format **[BusNumber, SlotNumber]**.

To determine the bus number and the PCI slot number, type:

```
tg = slrt;  
getPCIInfo(tg, 'installed')
```

External Websites

- www.ni.com

National Instruments PCI-6281 PWM Measure

PWM Measure block for PCI-6281 and PXI-6281 boards

Library

Simulink Real-Time Library for National Instruments

Description

Use this block to measure the pulse width or the period of a signal.

To measure the pulse width of a signal, connect the signal to the gate, as follows:

Counter	Gate Pin
0	PFI 9 (Pin 3)
1	PFI 4 (Pin 41)

The input waveform must have fast rise and fall times and conform to TTL signal levels of [0,5] volts. Use external signal conditioning to achieve these levels. If you input a sine wave, the decision points are less definite and the measurement is noisy. In extreme cases, the gate can transition multiple times during a slow signal transition.

This block does not queue or buffer measurements. If the gate changes state, the driver holds the current count, overwriting the previous value.

This block returns the length of the last gate period before the block executes.

To compute the duty cycle percentage, use two counters. Because the period of a cycle is H counter + L counter, you can measure two of these counters and compute the third.

You cannot measure a 0 width pulse.

Block Parameters

Counter

From the list, select a counter, 0 or 1.

Trigger mode

From the list, select the gating mode to use:

Mode	Description
Width of Gate High	Returns the number of 80 MHz cycles that occur when a single cycle of the input is high.
Width of Gate Low	Returns the number of 80 MHz cycles that occur when a single cycle of the input is low.
Between Rising Edges	Returns the number of 80 MHz cycles that occur between rising edges of the input signal. This cycle is the full period of the input signal.
Between Falling Edges	Returns the number of 80 MHz cycles that occur between falling edges of the input signal. This cycle is the full period of the input signal.

If the input signal has both fast rise and fall edges, **Between Rising Edges** and **Between Falling Edges** return the same value. If the input is asymmetric, one of these options can give a better result than the other.

Filter

You can apply a digital debouncing filter to the input pins before processing.

From the list, select a filter value to ignore pulses that are shorter than the filter time. The block ignores pulses shorter than the chosen duration. The value of **None** indicates that the input is not filtered

- None
- Minimum pulse width 125 nanoseconds
- Minimum pulse width 6.25 microseconds
- Minimum pulse width 1.25 milliseconds

Sample time

Enter the base sample time or a multiple of the base sample time (- 1 means sample time is inherited).

PCI slot (-1:autosearch)

If only one board of this type is in the target computer, enter - 1 to locate the board.

If two or more boards of this type are in the target computer, enter the bus number and the PCI slot number of the board associated with this driver block. Use the format **[BusNumber,SlotNumber]**.

To determine the bus number and the PCI slot number, type:

```
tg = slrt;  
getPCIInfo(tg, 'installed')
```

External Websites

- www.ni.com

National Instruments PCI-6289

Support for PCI-6289 and PXI-6289 boards

Board

National Instruments PCI-6289, PXI-6289

General Description

The 6289 M-series boards are data acquisition I/O boards with up to 32 single-ended or 16 differential 18-bit analog inputs, four 16-bit analog outputs, 48 digital I/O lines, and two 32-bit 80 MHz counters.

The Simulink Real-Time block library supports the 6289 boards with these driver blocks:

- National Instruments PCI-6289 Analog Input
- National Instruments PCI-6289 Analog Output
- National Instruments PCI-6289 Digital Input
- National Instruments PCI-6289 Digital Output
- National Instruments PCI-6289 Incremental Encoder
- National Instruments PCI-6289 PFI Digital Input
- National Instruments PCI-6289 PFI Digital Output
- National Instruments PCI-6289 PWM Generate
- National Instruments PCI-6289 PWM Measure

Board Characteristics

Board name	PCI-6289, PXI-6289
Manufacturer	National Instruments
Bus type	PCI, PXI (both use PCI version of blocks)
Multiple block instance support	A/D: No, D/A: No, Digital I/O: Yes

Multiple board support

Yes

External Websites

- www.ni.com

National Instruments PCI-6289 Analog Input

Analog Input block for PCI-6289 and PXI-6289 boards

Library

Simulink Real-Time Library for National Instruments

Scaling of Input to Output

I/O Module Input	Block Output Data Type	Scaling
Volts	Double	1

Block Parameters

Channel vector

Enter numbers between 1 and 32. This driver allows you to enter channel numbers in arbitrary order.

For example, to use the first, second, and fifth channels, enter

```
[1,2,5]
```

Number the lines beginning with 1 even if this board manufacturer starts numbering the lines with 0.

Range vector

Enter a range code for each of the channels in the channel vector. You can specify one value to replicate over the channel vector, or specify one for each channel. This driver allows each channel to be different. This board works only in bipolar mode.

The following table is a list of the ranges for this driver and the corresponding range codes.

Input Range (V)	Range Code
-10 to +10	10

Input Range (V)	Range Code
-5 to +5	5
-2 to +2	2
-1 to +1	1
-0.5 to +0.5	0.5
-0.2 to +0.2	0.2
-0.1 to +0.1	0.1

For example, if the first channel is -10 to +10 volts and the second and fifth channels are -1 to +1 volts, enter

[10, 1, 1]

Input coupling vector

Enter a coupling code for each of the channels in the channel vector. You can replicate one value over the channel vector, or specify one for each channel. This driver allows a different coupling for each channel.

The following table is a list of the couplings for this driver and the corresponding coupling codes.

Coupling	Coupling Code	Description
RSE	0	Analog input line connected to the positive input of the PGIA. Analog input ground (AIGND) internally connected to the negative input of the PGIA. See the National Instruments user manual.
NRSE	1	Analog input line connected to the positive input of the PGIA. Analog input sense (AISENSE) connected to the negative input of the PGIA. See the National Instruments user manual.
DIFF	2	First analog input line connected to the positive input of the PGIA. Second analog input line connected to the negative input of the PGIA. See the National Instruments user manual.

For example, if the first and second channels are single input and the fifth channel is a differential input, enter

[0,0,2]

National Instruments boards use a zero-based number scheme for differential mode channel pairs. Simulink Real-Time drivers use a one-based number scheme that adds a 1 to the I/O module number, as shown in the following table:

Zero-Based Channel Number		One-Based Channel Number	
+	-	+	-
0	8	1	9
1	9	2	10
2	10	3	11
3	11	4	12
4	12	5	13
5	13	6	14
6	14	7	15
7	15	8	16
16	24	17	25
17	25	18	26
18	26	19	27
19	27	20	28
20	28	21	29
21	29	22	30
22	30	23	31
23	31	24	32

The I/O module uses a second input 8 channels higher than the first channel as the negative input of the pair. In the example above, the I/O module would use the 13th channel as a differential input with the fifth channel.

If the module is set up for differential mode, you can read the data from either of the channels in the differential pair. For example, if you have a differential pair of 1 and 9, you can read the data from channel 1 or channel 9. However, you might want to read the lower channel number of the pair because it remains unchanged when you switch the input mode between single-ended and differential.

Scan interval

If **Channel vector** has more than one channel in it, enter the time between sampling different channels. Because execution waits for data to be available, this value increases the time to execute the block. If you enter a shorter time, you get the minimum 2e-6. If you enter a time smaller than this value, the time will still be 4e-6, which is the fastest this board can acquire data. See the National Instruments user manual for a discussion about settling time and the need to control the time between sampling different channels depending on the impedance of the signal source.

Sample time

Enter the base sample time or a multiple of the base sample time (- 1 means sample time is inherited).

PCI slot (-1:autosearch)

If only one board of this type is in the target computer, enter - 1 to locate the board.

If two or more boards of this type are in the target computer, enter the bus number and the PCI slot number of the board associated with this driver block. Use the format [**BusNumber,SlotNumber**].

To determine the bus number and the PCI slot number, type:

```
tg = slrt;  
getPCIInfo(tg, 'installed')
```

External Websites

- www.ni.com

National Instruments PCI-6289 Analog Output

Analog Output block for PCI-6289 and PXI-6289 boards

Library

Simulink Real-Time Library for National Instruments

Scaling of Output to Input

I/O Module Output	Block Input Data Type	Scaling
Volts	Double	1

Block Parameters

Channel vector

Enter 1 to 4. This driver allows the selection of individual D/A channels in arbitrary order. The number of elements defines the number of D/A channels used. For example, to use all analog output channels, enter

```
[1,2,3,4]
```

Number the channels begin with 1 even if this board manufacturer starts numbering the channels with 0.

Range vector

Enter a range code for each of the channels in the channel vector. The range vector must be the same length as the channel vector. This board allows the range of each channel to be different.

The following table is a list of the ranges for this driver and the corresponding range codes.

Input Range (V)	Range Code
-10 to +10	-10

Input Range (V)	Range Code
-5 to +5	-5
$V_{ref} \times sig$, where $-1 \leq sig \leq +1$	APFI0
$V_{ref} \times sig$, where $-1 \leq sig \leq +1$	APFI1

For example, if the first channel is -10 to +10 volts and the second channel is -5 to +5 volts, enter

[10,5]

Reset vector

The reset vector controls the behavior of the channel at model termination. Enter a scalar or a vector that is the same length as the channel vector. If you specify a scalar value, that setting is replicated over the channel vector. If you specify a value of 1, the corresponding channel is reset to the value specified in the initial value vector. If you specify a value of 0, the channel remains at the last value attained while the model was running.

Initial value vector

The initial value vector contains the initial voltage values for the output channels. Enter a scalar or a vector that is the same length as the channel vector. If you specify a scalar value, that value is replicated as the initial value over the channel vector. The channels are set to the initial values between the time the model is downloaded and the time it is started.

Sample time

Enter the base sample time or a multiple of the base sample time (-1 means sample time is inherited).

PCI slot (-1:autosearch)

If only one board of this type is in the target computer, enter -1 to locate the board.

If two or more boards of this type are in the target computer, enter the bus number and the PCI slot number of the board associated with this driver block. Use the format **[BusNumber, SlotNumber]**.

To determine the bus number and the PCI slot number, type:

```
tg = slrt;
getPCIInfo(tg, 'installed')
```

External Websites

- www.ni.com

National Instruments PCI-6289 Digital Input

Digital Input block for PCI-6289 and PXI-6289 boards

Library

Simulink Real-Time Library for National Instruments

Note

Models can have multiple digital input blocks for one physical board. In this case, the Simulink Real-Time environment executes the blocks based on their sorted order as determined by the Simulink software.

Each board has one set of static digital I/O ports. You can independently configure each port to be input or output.

If a digital input block shares channels with a digital output block, the input block reads the last value written to the digital output block on the overlapping channels.

Scaling of Input to Output

I/O Module Input	Block Output Data Type	Scaling
TTL	Double	TTL low ≥ 0.0 TTL high = 1.0

Block Parameters

Channel vector

Enter numbers between 1 and 32 to select the digital input lines used with this port. This driver allows the selection of individual digital input lines in arbitrary order. The number of elements defines the number of digital lines used.

For example, to use the first eight digital inputs for one port, enter

[1,2,3,4,5,6,7,8]

Number the lines beginning with 1 even if this board manufacturer starts numbering the lines with 0.

Sample time

Enter the base sample time or a multiple of the base sample time (- 1 means sample time is inherited).

PCI slot (-1:autosearch)

If only one board of this type is in the target computer, enter - 1 to locate the board.

If two or more boards of this type are in the target computer, enter the bus number and the PCI slot number of the board associated with this driver block. Use the format **[BusNumber,SlotNumber]**.

To determine the bus number and the PCI slot number, type:

```
tg = slrt;  
getPCIInfo(tg, 'installed')
```

External Websites

- www.ni.com

National Instruments PCI-6289 Digital Output

Digital Output block for PCI-6289 and PXI-6289 boards

Library

Simulink Real-Time Library for National Instruments

Note

Models can have multiple digital output blocks for one physical board. In this case, the Simulink Real-Time environment executes the blocks based on their sorted order as determined by the Simulink software.

Each board has one set of digital I/O ports. You can independently configure each port to be input or output.

If a digital input block shares channels with a digital output block, the input block reads the last value written to the digital output block on the overlapping channels.

The block compares the value written to each port with 0.5.

Value written	Block writes digital output with a value of...
≥ 0.5	1
< 0.5	0

Scaling of Output to Input

I/O Module Output	Block Input Data Type	Scaling
TTL	Double	$< 0.5 = \text{TTL low}$ $\geq 0.5 = \text{TTL high}$

Block Parameters

Channel vector

Enter numbers between 1 and 32 to select the digital output lines used with this port. This driver allows the selection of individual digital output lines in arbitrary order. The number of elements defines the number of digital lines used.

For example, to use the first eight digital outputs, enter

```
[1,2,3,4,5,6,7,8]
```

Number the lines beginning with 1 even if this board manufacturer starts numbering the lines with 0.

Reset vector

The reset vector controls the behavior of the channel at model termination. Enter a scalar or a vector that is the same length as the channel vector. If you specify a scalar value, that setting is replicated over the channel vector. If you specify a value of 1, the corresponding channel is reset to the value specified in the initial value vector. If you specify a value of 0, the channel remains at the last value attained while the model was running.

Initial value vector

The initial value vector contains the initial values (0 or 1) of the output channels. Enter a scalar or a vector that is the same length as the channel vector. If you enter a scalar, that value is replicated as the initial value over the channel vector. The channels are set to these initial values between the time the model is downloaded and the time it is started.

Sample time

Enter the base sample time or a multiple of the base sample time (- 1 means sample time is inherited).

PCI slot (-1:autosearch)

If only one board of this type is in the target computer, enter - 1 to locate the board.

If two or more boards of this type are in the target computer, enter the bus number and the PCI slot number of the board associated with this driver block. Use the format **[BusNumber,SlotNumber]**.

To determine the bus number and the PCI slot number, type:

```
tg = slrt;  
getPCIInfo(tg, 'installed')
```

External Websites

- www.ni.com

National Instruments PCI-6289 Incremental Encoder

Incremental Encoder block for PCI-6289 and PXI-6289 boards

Library

Simulink Real-Time Library for National Instruments

Scaling Input to Output

I/O Module Input	Block Output Data Type	Scaling
TTL level quadrature encoder signals	Double	counts

Block Parameters

Channel

From the list, choose 0 or 1 for the channel counter you want to use. For information on input for these counters, see the National Instruments M Series user manual. The pin associations are:

Counter	Channel 0	Channel 1
A	PFI 8 (Pin 37)	PFI 3 (Pin 42)
B	PFI 10 (Pin 45)	PFI 11 (Pin 46)
Z	PFI 9 (Pin 3)	PFI 4 (Pin 41)

Counting mode

From the list, select a counting mode:

Mode	Description
Quadrature Mode x1	Count on rising edges of the A signal
Quadrature Mode x2	Count on both rising and falling edges of the A signal

Mode	Description
Quadrature Mode x4	Count on both rising and falling edges of both A and B signals

The level of the opposite signal when an edge occurs determines the count direction. For example, a rising edge of A when B is high counts one way, while an edge of A when B is low counts the other. For more information, see the National Instruments M Series user manual.

Initial count

The initial count specifies the initial value for the counter. The block resets the count to this value under the following conditions:

- When the model starts
- When the following is true, which typically occurs once per revolution for a rotary encoder.
 - **Reload at index pulse** check box is selected
 - Index pulse (Z input) is true
 - The phases of A and B match the setting of **Index phase**

Reload at index pulse

Select this check box to reset the counter to the value of **Initial count** at each index pulse. The reset occurs when:

- The encoder outputs a high level on its index output
- The phases of A and B match the setting of **Index phase**

Index phase

If you have selected the **Reload at index pulse** check box, the **Index phase** parameter specifies the phase of the quadrature signals during which the count reloads with **Initial count**. Your choice of value primarily depends on the particular incremental encoder you use. From the list, select one:

- A low B low
- A low B high
- A high B low
- A high B high

To choose an **Index phase** for reset, use an oscilloscope, triggered on the index pulse, to observe the states of counters A and B. If your choice does not meet the encoder requirements, resets may be inconsistent.

Filter

You can apply a digital debouncing filter to the input pins before processing.

From the list, select a filter value to ignore pulses that are shorter than the filter time. The value of **NONE** indicates that the input is not filtered.

- None
- Minimum pulse width 125 nanoseconds
- Minimum pulse width 6.25 microseconds
- Minimum pulse width 1.25 milliseconds

Sample time

Enter the base sample time or a multiple of the base sample time (- 1 means sample time is inherited).

PCI slot (-1:autosearch)

If only one board of this type is in the target computer, enter - 1 to locate the board.

If two or more boards of this type are in the target computer, enter the bus number and the PCI slot number of the board associated with this driver block. Use the format **[BusNumber, SlotNumber]**.

To determine the bus number and the PCI slot number, type:

```
tg = slrt;  
getPCIInfo(tg, 'installed')
```

External Websites

- www.ni.com

National Instruments PCI-6289 PFI Digital Input

PFI Digital Input block for PCI-6289 and PXI-6289 boards

Library

Simulink Real-Time Library for National Instruments

Description

A model can have more than one PFI digital input block for a given physical board. If a model has more than one digital input block, it executes the blocks in the order that the Simulink software has determined.

The two counters and the PFI digital input and output blocks share the 16 PFI digital I/O lines. Follow these rules when using these blocks:

You can read a PFI bit with this digital input block when...	You cannot read a PFI bit with this digital input block when...
PWM measure block is using the bit	PWM generate block is using the bit
Incremental encoder block is using the bit	PFI digital output block is using the bit

Scaling of Input to Output

I/O Module Input	Block Output Data Type	Scaling
TTL	Double	TTL low ≥ 0.0 TTL high = 1.0

Block Parameters

PFI bit vector (0-15)

This block uses 0 based numbering to reflect the names of the bits described in the National Instruments M Series user manual.

Enter a vector that contains the bits you want to monitor. For example, to read bits PFI 0, PFI 5, and PFI 7, enter

```
[0, 5, 7]
```

Sample time

Enter the base sample time or a multiple of the base sample time (- 1 means sample time is inherited).

PCI slot (-1:autosearch)

If only one board of this type is in the target computer, enter - 1 to locate the board.

If two or more boards of this type are in the target computer, enter the bus number and the PCI slot number of the board associated with this driver block. Use the format **[BusNumber, SlotNumber]**.

To determine the bus number and the PCI slot number, type:

```
tg = slrt;  
getPCIInfo(tg, 'installed')
```

External Websites

- www.ni.com

National Instruments PCI-6289 PFI Digital Output

PFI Digital Output block for PCI-6289 and PXI-6289 boards

Library

Simulink Real-Time Library for National Instruments

Description

A model can have more than one PFI digital input block for a given physical board. If a model has more than one digital input block, it executes the blocks in the order that the Simulink software has determined.

The two counters and the PFI digital input and output blocks share the 16 PFI digital I/O lines. Follow these rules when using these blocks:

- Do not use a PFI bit as a digital output when the PDF digital input block is using the bit.
- Do not use a PFI bit as a digital output when the incremental encoder is using the bit.
- Do not use a PFI bit for digital output when the PWM generate block is using the bit.

Scaling of Output to Input

I/O Module Output	Block Input Data Type	Scaling
TTL	Double	< 0.5 = TTL low ≥ 0.5 = TTL high

Block Parameters

PFI bit vector (0-15)

This block uses 0 based numbering to reflect the names of the bits described in the National Instruments M Series user manual.

Enter a vector that contains the bits you want to control. For example, to write bits PFI 1, PFI 3, and PFI 9, enter

```
[1, 3, 9]
```

Reset vector

The reset vector controls the behavior of the channel at model termination. Enter a scalar or a vector that is the same length as the channel vector. If you specify a scalar value, that setting is replicated over the channel vector. If you specify a value of 1, the corresponding channel is reset to the value specified in the initial value vector. If you specify a value of 0, the channel remains at the last value attained while the model was running.

Initial value vector

The initial value vector contains the initial values (0 or 1) of the block outputs. Enter a scalar or a vector of values, one for each output. If you enter a scalar, the driver replicates that value over the output vector.

The block applies this value as follows:

- The model uses this value when you first download the model to the target computer.
- If you set **Reset vector** to 1, the block output is reset to this value when model execution stops. If the value is greater than 0.5, the block sets output to **HIGH**. If the value is less than or equal to 0.5, the block sets the output to **LOW**.

Sample time

Enter the base sample time or a multiple of the base sample time (-1 means sample time is inherited).

PCI slot (-1:autosearch)

If only one board of this type is in the target computer, enter -1 to locate the board.

If two or more boards of this type are in the target computer, enter the bus number and the PCI slot number of the board associated with this driver block. Use the format [**BusNumber**, **SlotNumber**].

To determine the bus number and the PCI slot number, type:

```
tg = slrt;  
getPCIInfo(tg, 'installed')
```

External Websites

- www.ni.com

National Instruments PCI-6289 PWM Generate

PWM Generate block for PCI-6289 and PXI-6289 boards

Library

Simulink Real-Time Library for National Instruments

Description

Use this block to generate variable frequency and pulse width output.

The M Series boards have two 32-bit counters that you can use to generate pulse trains. Inputs are in counts of the 80 MHz reference frequency on the onboard clock.

- H input is the number of counts that the output is high.
- L input is the number of counts that the output is low.

If the H input goes to 0, the output stays low. If the L input goes to 0, the output stays high. If both are 0, the output goes low.

Block Parameters

Counter

From the list, select the counter, 0 or 1, that you want to use. The output for these counters is on the following pins:

Counter	Pin
0	PFI 12 (Pin 2)
1	PFI 13 (Pin 40)

Initial high count

Enter the number of counts the output is high between the time the Simulink engine calls the `mdlStart` routine for this block and the first time it calls `mdlOutputs`. This

length of time depends on the number of blocks in the model and the sorted order as determined by the Simulink software.

If you enter a value of 0, the output stays low until the first time the Simulink engine calls `mdlOutputs`.

Initial low count

Enter the number of counts the output is low between the time the Simulink engine calls the `mdlStart` routine for this block and the first time it calls `mdlOutputs`. This length of time depends on the number of blocks in the model and the sorted order as determined by the Simulink software. If you enter a value of 0, the output stays high until the first time the Simulink engine calls `mdlOutputs`, unless you have also set `H` to 0.

Arm input

Select this check box to add a third input port to the block.

- If the input connected to this port is greater than 0.5, the block arms the counter. Output then occurs.
- If the input connected to this port is less than or equal to 0.5, the block disarms the counter and the output goes to the level of the value in the **Disarm level** parameter.

Disarm level

From the list, select the disarm level **Disarm to LOW** or **Disarm to HIGH**. If the model disarms the block and the level of the value is **Arm input**, the output goes to the level you select here.

Stop level

From the list, select the stop level **Stop to LOW** or **Stop to HIGH**. When model execution stops, the output goes to the level you choose here.

Sample time

Enter the base sample time or a multiple of the base sample time (-1 means sample time is inherited).

PCI slot (-1:autosearch)

If only one board of this type is in the target computer, enter -1 to locate the board.

If two or more boards of this type are in the target computer, enter the bus number and the PCI slot number of the board associated with this driver block. Use the format **[BusNumber, SlotNumber]**.

To determine the bus number and the PCI slot number, type:

```
tg = slrt;  
getPCIInfo(tg, 'installed')
```

External Websites

- www.ni.com

National Instruments PCI-6289 PWM Measure

PWM Measure block for PCI-6289 and PXI-6289 boards

Library

Simulink Real-Time Library for National Instruments

Description

Use this block to measure the pulse width or the period of a signal.

To measure the pulse width of a signal, connect the signal to the gate, as follows:

Counter	Gate Pin
0	PFI 9 (Pin 3)
1	PFI 4 (Pin 41)

The input waveform must have fast rise and fall times and conform to TTL signal levels of [0,5] volts. Use external signal conditioning to achieve these levels. If you input a sine wave, the decision points are less definite and the measurement is noisy. In extreme cases, the gate can transition multiple times during a slow signal transition.

This block does not queue or buffer measurements. If the gate changes state, the driver holds the current count, overwriting the previous value.

This block returns the length of the last gate period before the block executes.

To compute the duty cycle percentage, use two counters. Because the period of a cycle is H counter + L counter, you can measure two of these counters and compute the third.

You cannot measure a 0 width pulse.

Block Parameters

Counter

From the list, select a counter, 0 or 1.

Trigger mode

From the list, select the gating mode to use:

Mode	Description
Width of Gate High	Returns the number of 80 MHz cycles that occur when a single cycle of the input is high.
Width of Gate Low	Returns the number of 80 MHz cycles that occur when a single cycle of the input is low.
Between Rising Edges	Returns the number of 80 MHz cycles that occur between rising edges of the input signal. This cycle is the full period of the input signal.
Between Falling Edges	Returns the number of 80 MHz cycles that occur between falling edges of the input signal. This cycle is the full period of the input signal.

If the input signal has both fast rise and fall edges, **Between Rising Edges** and **Between Falling Edges** return the same value. If the input is asymmetric, one of these options can give a better result than the other.

Filter

You can apply a digital debouncing filter to the input pins before processing.

From the list, select a filter value to ignore pulses that are shorter than the filter time. The block ignores pulses shorter than the chosen duration. The value of **None** indicates that the input is not filtered

- None
- Minimum pulse width 125 nanoseconds
- Minimum pulse width 6.25 microseconds
- Minimum pulse width 1.25 milliseconds

Sample time

Enter the base sample time or a multiple of the base sample time (- 1 means sample time is inherited).

PCI slot (-1:autosearch)

If only one board of this type is in the target computer, enter - 1 to locate the board.

If two or more boards of this type are in the target computer, enter the bus number and the PCI slot number of the board associated with this driver block. Use the format **[BusNumber,SlotNumber]**.

To determine the bus number and the PCI slot number, type:

```
tg = slrt;  
getPCIInfo(tg, 'installed')
```

External Websites

- www.ni.com

National Instruments PCI-6503

Support for National Instruments PCI-6503 board

Board

National Instruments PCI-6503

General Description

The PCI-6503 is an I/O board with 24 digital input and output lines.

The Simulink Real-Time block library supports this board with these driver blocks:

- National Instruments PCI-6503 Digital Input
- National Instruments PCI-6503 Digital Output

Board Characteristics

Board name	PCI-6503
Manufacturer	National Instruments
Bus type	PCI
Access method	I/O mapped
Multiple block instance support	Yes
Multiple board support	Yes

External Websites

- www.ni.com

National Instruments PCI-6503 Digital Input

National Instruments PCI-6503 Digital Input block

Library

Simulink Real-Time Library for National Instruments

Note

The PCI-6503 has one 8255 chip with 3 ports (A,B,C). Each port has a maximum of 8 digital I/O lines that can be configured as inputs or outputs.

Use a separate driver block for each port. By selecting the digital input driver block, the port is configured as input.

Scaling of Input to Output

I/O Module Input	Block Output Data Type	Scaling
TTL	Double	TTL low = 0.0 TTL high = 1.0

Block Parameters

Channel vector

Enter numbers between 1 and 8 to select the digital input lines used with this port. This driver allows the selection of individual digital input lines in arbitrary order. The number of elements defines the number of digital lines used.

For example, to use all of the digital inputs for one port, enter

```
[1,2,3,4,5,6,7,8]
```

Number the lines beginning with 1 even if this board manufacturer starts numbering the lines with 0.

Port

From the list, choose either **A**, **B**, or **C**. The I/O board has an 8255 chip with 3 ports. The **Port** parameter defines which port of the 8255 chip is used for this driver block. Each port has a maximum of 8 digital lines that can be configured as inputs or outputs depending on which driver block is chosen. In each case, one block is required for each port.

Sample time

Enter the base sample time or a multiple of the base sample time (- 1 means sample time is inherited).

PCI slot (-1:autosearch)

If only one board of this type is in the target computer, enter -1 to locate the board.

If two or more boards of this type are in the target computer, enter the bus number and the PCI slot number of the board associated with this driver block. Use the format [**BusNumber**, **SlotNumber**].

To determine the bus number and the PCI slot number, type:

```
tg = slrt;  
getPCIInfo(tg, 'installed')
```

External Websites

- www.ni.com

National Instruments PCI-6503 Digital Output

National Instruments PCI-6503 Digital Output block

Library

Simulink Real-Time Library for National Instruments

Note

The PCI-6503 has one 8255 chip with 3 ports (A,B,C). Each port has a maximum of 8 digital I/O lines that can be configured as inputs or outputs.

Use a separate driver block for each port. By selecting the digital output driver block, the port is configured as output.

Scaling of Input to Output

I/O Module Output	Block Input Data Type	Scaling
TTL	Double	$< 0.5 = \text{TTL low}$ $\geq 0.5 = \text{TTL high}$

Block Parameters

Channel vector

Enter numbers between 1 and 8 to select the digital output lines used with this port. This driver allows the selection of individual digital output lines in arbitrary order. The number of elements defines the number of digital lines used.

For example, to use all of the digital outputs for one port, enter

```
[1,2,3,4,5,6,7,8]
```

Number the lines beginning with 1 even if this board manufacturer starts numbering the lines with 0.

Port

From the list, choose either **A**, **B**, or **C**. The I/O board has an 8255 chip with 3 ports. The **Port** parameter defines which port of the 8255 chip is used for this driver block. Each port has a maximum of 8 digital lines that can be configured as inputs or outputs depending on which driver block is chosen. In each case, one block is required for each port.

Reset vector

The reset vector controls the behavior of the channel at model termination. Enter a scalar or a vector that is the same length as the channel vector. If you specify a scalar value, that setting is replicated over the channel vector. If you specify a value of 1, the corresponding channel is reset to the value specified in the initial value vector. If you specify a value of 0, the channel remains at the last value attained while the model was running.

Initial value vector

The initial value vector contains the initial values (0 or 1) of the output channels. Enter a scalar or a vector that is the same length as the channel vector. If you enter a scalar, that value is replicated as the initial value over the channel vector. The channels are set to these initial values between the time the model is downloaded and the time it is started.

Sample time

Enter the base sample time or a multiple of the base sample time (-1 means sample time is inherited).

PCI slot (-1:autosearch)

If only one board of this type is in the target computer, enter -1 to locate the board.

If two or more boards of this type are in the target computer, enter the bus number and the PCI slot number of the board associated with this driver block. Use the format **[BusNumber, SlotNumber]**.

To determine the bus number and the PCI slot number, type:

```
tg = slrt;  
getPCIInfo(tg, 'installed')
```

External Websites

- www.ni.com

National Instruments PCI-6527

Support for National Instruments PCI-6527 board

Board

National Instruments PCI-6527

General Description

The PCI-6527 is an I/O board with 24 filtered digital input lines and 24 digital output lines. You can turn input filtering on or off individually for each of the 24 input lines, but the same filter time applies to each line.

The Simulink Real-Time block library supports this board with these driver blocks:

- National Instruments PCI-6527 Digital Input
- National Instruments PCI-6527 Digital Output

Board Characteristics

Board name	PCI-6527
Manufacturer	National Instruments
Bus type	PCI
Access method	Memory mapped
Multiple block instance support	Digital I/O: Yes
Multiple board support	Yes

External Websites

- www.ni.com

National Instruments PCI-6527 Digital Input

National Instruments PCI-6527 Digital Input block

Library

Simulink Real-Time Library for National Instruments

Note

The PCI-6527 has one chip with 3 ports (A,B,C) for digital input. Each port has a maximum of 8 digital I/O lines. Use a separate driver block for each port.

Note: The interrupt on change capability of this board is not used.

Scaling of Input to Output

I/O Module Input	Block Input Data Type	Scaling
OPTO	Double	$< 0.5 = 0$ $\geq 0.5 = 1$

Block Parameters

Channel vector

Enter numbers between 1 and 8 to select the digital input lines used with this port. This driver allows the selection of individual digital input lines in arbitrary order. The number of elements defines the number of digital lines used.

For example, to use all of the digital inputs for one port, enter

[1,2,3,4,5,6,7,8]

Number the lines beginning with 1 even if this board manufacturer starts numbering the lines with 0.

Port

From the list, choose either **A**, **B**, or **C**. The **Port** parameter defines which port is used for this driver block. Each port has a maximum of 8 digital inputs. In each case, one block is required for each port.

The documentation for this board from National Instruments labels these ports 0, 1, and 2.

Filter vector

This is a Boolean vector that selects which input lines to filter. For example, if you enter a **Channel vector** of [1, 3, 5], and you want to filter all three lines, enter

```
[ 1, 1, 1 ]
```

If you want to filter lines 1 and 5, but not line 3, then enter

```
[ 1, 0, 1 ]
```

If the filter vector is a single element, then it is scalar expanded to the same width as the **Channel vector**. In the example above, if the **Filter vector** is [0], it is expanded to [0, 0, 0]. Likewise, if the **Filter vector** is [1] it is expanded to [1, 1, 1].

Filter interval

Enter the time interval the filter uses to determine a stable pulse. If the input pulse is shorter than this interval, it is ignored. The same filter interval applies to each filtered input, and if you filter on more than one digital input block for this board, you must enter the same **Filter interval** for each block.

A reasonable value for the **Filter interval** would be 200 to 300 us.

Sample time

Enter the base sample time or a multiple of the base sample time (- 1 means sample time is inherited).

PCI slot (-1:autosearch)

If only one board of this type is in the target computer, enter - 1 to locate the board.

If two or more boards of this type are in the target computer, enter the bus number and the PCI slot number of the board associated with this driver block. Use the format [**BusNumber**, **SlotNumber**].

To determine the bus number and the PCI slot number, type:

```
tg = slrt;  
getPCIInfo(tg, 'installed')
```

External Websites

- www.ni.com

National Instruments PCI-6527 Digital Output

PCI-6527 Digital Output block

Library

Simulink Real-Time Library for National Instruments

Note

The PCI-6527 has one chip with 3 ports (A,B,C) for digital output. Each port has a maximum of 8 digital output lines. Use a separate driver block for each port.

Scaling of Input to Output

I/O Module Output	Block Output Data Type	Scaling
OPTO	Double	<0.5 = OPTO is OFF, current not flowing ≥ 0.5 = OPTO is ON, current can flow

Block Parameters

Channel vector

Enter numbers between 1 and 8 to select the digital output lines used with this port. This driver allows the selection of individual digital output lines in arbitrary order. The number of elements defines the number of digital lines used.

For example, to use all of the digital outputs for one port, enter

[1,2,3,4,5,6,7,8]

Number the lines beginning with 1 even if this board manufacturer starts numbering the lines with 0.

Port

From the list, choose either **A**, **B**, or **C**. The **Port** parameter defines which port is used for this driver block. Each port has a maximum of 8 digital output lines. In each case, one block is required for each port.

The documentation for this board from National Instruments labels these ports 3, 4, and 5.

Reset vector

The reset vector controls the behavior of the channel at model termination. Enter a scalar or a vector that is the same length as the channel vector. If you specify a scalar value, that setting is replicated over the channel vector. If you specify a value of 1, the corresponding channel is reset to the value specified in the initial value vector. If you specify a value of 0, the channel remains at the last value attained while the model was running.

Initial value vector

The initial value vector contains the initial voltage values for the output channels. Enter a scalar or a vector that is the same length as the channel vector. If you specify a scalar value, that value is replicated as the initial value over the channel vector. The channels are set to the initial values between the time the model is downloaded and the time it is started.

Sample time

Enter the base sample time or a multiple of the base sample time (-1 means sample time is inherited).

PCI slot (-1:autosearch)

If only one board of this type is in the target computer, enter -1 to locate the board.

If two or more boards of this type are in the target computer, enter the bus number and the PCI slot number of the board associated with this driver block. Use the format [**BusNumber**, **SlotNumber**].

To determine the bus number and the PCI slot number, type:

```
tg = slrt;  
getPCIInfo(tg, 'installed')
```

External Websites

- www.ni.com

National Instruments PCI-6528

Support for National Instruments PCI-6528 board

Board

National Instruments PCI-6528

General Description

The PCI-6528 is an I/O board with 24 filtered digital input lines and 24 digital output lines. You can individually turn input filtering on or off for each of the 24 input lines, but the same filter time applies to each line.

The Simulink Real-Time block library supports this board with these driver blocks:

- National Instruments PCI-6527 Digital Input
- National Instruments PCI-6527 Digital Output

Board Characteristics

Board name	PCI-6528
Manufacturer	National Instruments
Bus type	PCI
Access method	Memory mapped
Multiple block instance support	Digital I/O: Yes
Multiple board support	Yes

External Websites

- www.ni.com

National Instruments PCI-6528 Digital Input

PCI-6528 Digital Input block

Library

Simulink Real-Time Library for National Instruments

Note

The PCI-6528 has one chip with 3 ports (A,B,C) for digital input. Each port has a maximum of 8 digital I/O lines. Use a separate driver block for each port.

Note: The interrupt-on-change capability of this board is not used.

Scaling of Input to Output

I/O Module Input	Block Input Data Type	Scaling
OPTO	Double	$< 0.5 = 0$ $\geq 0.5 = 1$

Block Parameters

Channel vector

Enter numbers between 1 and 8 to select the digital input lines used with this port. This driver allows the selection of individual digital input lines in arbitrary order. The number of elements defines the number of digital lines used.

For example, to use all of the digital inputs for one port, enter

[1,2,3,4,5,6,7,8]

Number the lines beginning with 1 even if this board manufacturer starts numbering the lines with 0.

Port

From the list, choose either **A**, **B**, or **C**. The **Port** parameter defines which port is used for this driver block. Each port has a maximum of 8 digital inputs. In each case, one block is required for each port.

The documentation for this board from National Instruments labels these ports 0, 1, and 2.

Filter vector

This is a Boolean vector that selects which input lines to filter. For example, if you enter a **Channel vector** of [1, 3, 5], and you want to filter all three lines, enter

```
[ 1, 1, 1 ]
```

If you want to filter lines 1 and 5, but not line 3, then enter

```
[ 1, 0, 1 ]
```

If the filter vector is a single element, then it is scalar expanded to the same width as the **Channel vector**. In the example above, if the **Filter vector** is [0], it is expanded to [0, 0, 0]. Likewise, if the **Filter vector** is [1] it is expanded to [1, 1, 1].

Filter interval

Enter the time interval the filter uses to determine a stable pulse. If the input pulse is shorter than this interval, it is ignored. The same filter interval applies to each filtered input, and if you filter on more than one digital input block for this board, you must enter the same **Filter interval** for each block.

A reasonable value for the **Filter interval** would be 200 to 300 μ s.

Sample time

Enter the base sample time or a multiple of the base sample time (- 1 means sample time is inherited).

PCI slot (-1:autosearch)

If only one board of this type is in the target computer, enter - 1 to locate the board.

If two or more boards of this type are in the target computer, enter the bus number and the PCI slot number of the board associated with this driver block. Use the format [**BusNumber**, **SlotNumber**].

To determine the bus number and the PCI slot number, type:

```
tg = slrt;  
getPCIInfo(tg, 'installed')
```

External Websites

- www.ni.com

National Instruments PCI-6528 Digital Output

PCI-6528 Digital Output block

Library

Simulink Real-Time Library for National Instruments

Note

The PCI-6528 has one chip with 3 ports (A,B,C) for digital output. Each port has a maximum of 8 digital output lines. Use a separate driver block for each port.

Scaling of Input to Output

I/O Module Output	Block Output Data Type	Scaling
OPTO	Double	<0.5 = OPTO is OFF, current not flowing ≥0.5 = OPTO is ON, current can flow

Block Parameters

Channel vector

Enter numbers between 1 and 8 to select the digital output lines used with this port. This driver allows the selection of individual digital output lines in arbitrary order. The number of elements defines the number of digital lines used.

For example, to use all of the digital outputs for one port, enter

[1,2,3,4,5,6,7,8]

Number the lines beginning with 1 even if this board manufacturer starts numbering the lines with 0.

Port

From the list, choose either **A**, **B**, or **C**. The **Port** parameter defines which port is used for this driver block. Each port has a maximum of 8 digital output lines. In each case, one block is required for each port.

The documentation for this board from National Instruments labels these ports 3, 4, and 5.

Reset vector

The reset vector controls the behavior of the channel at model termination. Enter a scalar or a vector that is the same length as the channel vector. If you specify a scalar value, that setting is replicated over the channel vector. If you specify a value of 1, the corresponding channel is reset to the value specified in the initial value vector. If you specify a value of 0, the channel remains at the last value attained while the model was running.

Initial value vector

The initial value vector contains the initial voltage values for the output channels. Enter a scalar or a vector that is the same length as the channel vector. If you specify a scalar value, that value is replicated as the initial value over the channel vector. The channels are set to the initial values between the time the model is downloaded and the time it is started.

Sample time

Enter the base sample time or a multiple of the base sample time (-1 means sample time is inherited).

PCI slot (-1:autosearch)

If only one board of this type is in the target computer, enter -1 to locate the board.

If two or more boards of this type are in the target computer, enter the bus number and the PCI slot number of the board associated with this driver block. Use the format [**BusNumber**, **SlotNumber**].

To determine the bus number and the PCI slot number, type:

```
tg = slrt;  
getPCIInfo(tg, 'installed')
```

External Websites

- www.ni.com

National Instruments PCI-6601

Support for National Instruments PCI-6601 board

Board

National Instruments PCI-6601

General Description

The National Instruments PCI-6601 is a general-purpose counter/timer board. It has four 32-bit counter channels. The reference frequency for this board is 20 MHz.

The Simulink Real-Time block library supports this board with the following driver blocks:

- National Instruments PCI-6601 Digital Input
- National Instruments PCI-6601 Digital Output
- National Instruments PCI-6601 Incremental Encoder
- National Instruments PCI-6601 Pulse Generation
- National Instruments PCI-6601 Pulse Width/Period Measurement
- National Instruments PCI-6601 Armed Pulse Generation
- National Instruments PCI-6601 Event Counter

The Simulink Real-Time software does not support the interrupt or timer functionality of the board.

Board Characteristics

Board name	PCI-6601
Manufacturer	National Instruments
Bus type	PCI
Access method	I/O mapped

Multiple block instance support Yes

Multiple board support Yes

External Websites

- www.ni.com

National Instruments PCI-6601 Digital Input

PCI-6601 Digital Input block

Library

Simulink Real-Time Library for National Instruments

Note

Only one input block can exist in a model for a particular board.

Block Parameters

Channel

Enter numbers between 1 and 8 to select the digital input ports. This driver allows the selection of individual digital input ports in arbitrary order. The number of elements defines the number of digital lines used.

For example, to use the first four ports as digital input channels, enter

```
[1,2,3,4]
```

Number the lines beginning with 1 even if this board manufacturer starts numbering the ports with 0.

Note: Treat the eight I/O ports as two groups of four ports. The two groups are ports 1 to 4 and ports 5 to 8. Do not specify both input and output channels in the same group of four ports. The driver will emit an error.

Sample time

Enter the base sample time or a multiple of the base sample time (- 1 means sample time is inherited).

PCI slot (-1:autosearch)

If only one board of this type is in the target computer, enter -1 to locate the board.

If two or more boards of this type are in the target computer, enter the bus number and the PCI slot number of the board associated with this driver block. Use the format **[BusNumber,SlotNumber]**.

To determine the bus number and the PCI slot number, type:

```
tg = slrt;  
getPCIInfo(tg, 'installed')
```

External Websites

- www.ni.com

National Instruments PCI-6601 Digital Output

PCI-6601 Digital Output block

Library

Simulink Real-Time Library for National Instruments

Note

Only one output block can exist in a model for a particular board.

Block Parameters

Channel

Enter numbers between 1 and 8 to select the digital output ports. This driver allows the selection of individual digital output ports in arbitrary order. The number of elements defines the number of digital lines used.

For example, to use the last four ports as digital output channels, enter

```
[5,6,7,8]
```

Number the lines beginning with 1 even if this board manufacturer starts numbering the ports with 0.

Note: Treat the eight I/O ports as two groups of four ports. The two groups are ports 1 to 4 and ports 5 to 8. Do not specify both input and output channels in the same group of four ports. The driver will emit an error.

Reset vector

The reset vector controls the behavior of the channel at model termination. Enter a scalar or a vector that is the same length as the channel vector. If you specify a scalar value, and the **Channel** parameter is longer, that value is replicated over

the channel vector. If you specify a value of 1, the corresponding channel is reset to the value specified in the initial value vector. If you specify a value of 0, the channel remains at the last value attained while the model was running.

For example, if the block parameters are set as follows:

- **Channel** — [5 6 7 8]
- **Reset vector** — [1 1 0 0]
- **Initial value vector** — [1 0 1 0]

Channels 5 and 6 will reset to the initial value vector. Channels 7 and 8 will hold at the last value attained while the model was running.

Initial value vector

The initial value vector contains the initial voltage values for the output channels. Enter a scalar or a vector that is the same length as the channel vector. If you specify a scalar value, that value is replicated over the channel vector. The channels are set to the initial values between the time the model is downloaded and the time it is started.

When execution stops, the driver writes the vector values to the output channels if the corresponding entry in the **Reset vector** is set to 1.

For example, if the block parameters are set as follows:

- **Channel** — [5 6 7 8]
- **Reset vector** — [1 1 0 0]
- **Initial value vector** — [1 0 1 0]

When the real-time application is downloaded to the target, channel 5 is set to 1, channel 6 is set to 0, channel 7 is set to 1 and channel 8 is set to 0.

After the real-time application executes, then stops, channel 5 will be set back to 1 and channel 6 will be set to 0. Channels 7 and 8 will hold the last values attained.

Sample time

Enter the base sample time or a multiple of the base sample time (-1 means sample time is inherited).

PCI slot (-1:autosearch)

If only one board of this type is in the target computer, enter -1 to locate the board.

If two or more boards of this type are in the target computer, enter the bus number and the PCI slot number of the board associated with this driver block. Use the format **[BusNumber,SlotNumber]**.

To determine the bus number and the PCI slot number, type:

```
tg = slrt;  
getPCIInfo(tg, 'installed')
```

External Websites

- www.ni.com

National Instruments PCI-6601 Incremental Encoder

PCI-6601 Incremental Encoder block

Library

Simulink Real-Time Library for National Instruments

Block Parameters

Channel

From the list, select a channel number between 1 and 4.

Note: If you want to attach a 3-wire encoder, do so by connecting the channel A signal to a SOURCE pin, the channel B signal to the AUX pin, and the index signal to the GATE pin.

Counting mode

From the list, select a counting mode:

- Normal
- Quadrature Mode X1
- Quadrature Mode X2
- Quadrature Mode X4
- Two-pulse mode
- Synchronous Source Mode

Initial count

The initial count specifies the initial value for the counter. Enter a nonnegative integer.

Reload at index pulse

Select this check box to have the count value reset to the value of **Initial count** at each index pulse.

Index phase

If the **Reload at index pulse** check box is selected, the **Index phase** parameter specifies the phase of the quadrature signals during which the count will be reloaded with **Initial count**. The count is reloaded in response to a channel index pulse. From the list, select one of the following:

- A low B low
- A low B high
- A high B low
- A high B high

Filter

You can apply a digital debouncing filter to the input pins prior to processing. From the list, select one of the following filter types:

- None
- Synchronize input to Timebase 3 (20 MHz)
- Minimum pulse width 5 microsec
- Minimum pulse width 1 microsec
- Minimum pulse width 500 nanosec
- Minimum pulse width 100 nanosec
- Minimum pulse width 25 nanosec

Sample time

Enter the base sample time or a multiple of the base sample time (-1 means sample time is inherited).

PCI slot (-1:autosearch)

If only one board of this type is in the target computer, enter -1 to locate the board.

If two or more boards of this type are in the target computer, enter the bus number and the PCI slot number of the board associated with this driver block. Use the format **[BusNumber,SlotNumber]**.

To determine the bus number and the PCI slot number, type:

```
tg = slrt;  
getPCIInfo(tg, 'installed')
```

External Websites

- www.ni.com

National Instruments PCI-6601 Pulse Generation

PCI-6601 Pulse Generation block

Library

Simulink Real-Time Library for National Instruments

Note

The inputs to the block are separate, one for the high count and one for the low count.

Block Parameters

Channel

From the list, choose one of the following:

- 1
- 2
- 3
- 4

These parameters specify the counter(s) to be used with this driver block. In each case, one block is required for each port.

The reference frequency for this board is 20 MHz.

Initial high count

Enter the number of clock ticks the counter should maintain for a high level.

Initial low count

Enter the number of clock ticks the counter should maintain at a low level.

Sample time

Enter the base sample time or a multiple of the base sample time (- 1 means sample time is inherited).

PCI slot (-1:autosearch)

If only one board of this type is in the target computer, enter -1 to locate the board.

If two or more boards of this type are in the target computer, enter the bus number and the PCI slot number of the board associated with this driver block. Use the format **[BusNumber,SlotNumber]**.

To determine the bus number and the PCI slot number, type:

```
tg = slrt;  
getPCIInfo(tg, 'installed')
```

External Websites

- www.ni.com

National Instruments PCI-6601 Pulse Width/Period Measurement

PCI-6601 Pulse Width/Period Measurement block

Library

Simulink Real-Time Library for National Instruments

Note

Connect the signal you want to measure to the GATE input of the chosen counter. The signal must have fast rise and fall times; otherwise, the counter might experience false triggering. Use signal voltage levels between 0 and 5 volts (TTL levels).

Block Parameters

Channel

From the list, choose one of the following:

- 1
- 2
- 3
- 4

These parameters specify the counter(s) to be used with this driver block. In each case, one block is required for each port.

Trigger mode

From the list, choose **Level Triggered** or **Edge Triggered**. See the table below for an example of how **Trigger mode** and **Polarity** interact. In this table, the data in the Output column resulted from a 1 kHz pulse train with a 25% low and a 75% high pulse.

Polarity

From the list, choose **Active low** or **Active high**. See the table below for an example of how **Trigger mode** and **Polarity** interact. In this table, the data in the Output column resulted from a 1 kHz pulse train with a 25% low and a 75% high pulse.

Measurement Objective	Trigger Mode	Polarity	Output
Pulse width (low pulse)	Level triggered	Active low	5000
Pulse width (high pulse)	Level triggered	Active high	15000
Period	Edge triggered	NA	20000

In every case, the output of the block is the number of clock ticks (of the 20 MHz source clock) required for the specified measurement. When measuring pulse width, the output reflects the number of clock ticks for which the input signal was in the specified (low or high) state. See the table above for an example.

Sample time

Enter the base sample time or a multiple of the base sample time (- 1 means sample time is inherited).

PCI slot (-1:autosearch)

If only one board of this type is in the target computer, enter - 1 to locate the board.

If two or more boards of this type are in the target computer, enter the bus number and the PCI slot number of the board associated with this driver block. Use the format **[BusNumber, SlotNumber]**.

To determine the bus number and the PCI slot number, type:

```
tg = slrt;
getPCIInfo(tg, 'installed')
```

External Websites

- www.ni.com

National Instruments PCI-6601 Armed Pulse Generation

PCI-6601 Armed Pulse Generation block

Library

Simulink Real-Time Library for National Instruments

Note

The inputs to the block are separate, one for the high count (H), one for the low count (L), and one for the arm input (A). If the arm input signal is less than 0.5, the frequency generation is disabled. If the arm input signal is greater than or equal to 0.5, the frequency generation is enabled.

Block Parameters

Channel

From the list, choose one of the following:

- 1
- 2
- 3
- 4

These parameters specify the counter to be used with this driver block. In each case, one block is required for each port.

The reference frequency for this board is 20 MHz.

Initial high count

Enter the number of clock ticks the counter should maintain for a high level.

Initial low count

Enter the number of clock ticks the counter should maintain at a low level.

Sample time

Enter the base sample time or a multiple of the base sample time (- 1 means sample time is inherited).

PCI slot (-1:autosearch)

If only one board of this type is in the target computer, enter - 1 to locate the board.

If two or more boards of this type are in the target computer, enter the bus number and the PCI slot number of the board associated with this driver block. Use the format **[BusNumber,SlotNumber]**.

To determine the bus number and the PCI slot number, type:

```
tg = slrt;  
getPCIInfo(tg, 'installed')
```

External Websites

- www.ni.com

National Instruments PCI-6601 Event Counter

PCI-6601 Event Counter block

Library

Simulink Real-Time Library for National Instruments

Description

The Event Counter is used for such tasks as measuring the frequency of a pulse train and counting binary events, such as switch closures and photocell interruptions (see “Examples” on page 46-405).

Block Parameters

Channel

From the list, choose one of the following:

- 1
- 2
- 3
- 4

These parameters specify the counter to be used with this driver block (I/O module channels 0–3). In each case, one block is required for each counter.

Counting Mode

Select one of:

- Cumulative counter

Accumulates count of edges of the source signal. Counter is reset according to **Reset Mode**. Block returns the current count without latching.

- HW gated cumulative counter

Accumulates count of edges of the source signal when the gate condition is true. Counter is reset according to **Reset Mode** (the gate end does *not* reset the count). Block returns the current count without latching.

Tip Use **Gate Trigger Mode** values **Level Active High** or **Level Active Low** in this mode. Edge gating produces a simple cumulative counter that starts with the first edge after arming the counter.

- HW gated latched counter

Accumulates count of edges of the source signal when the gate condition is true. Gate end latches the count and resets the count to the reset value for the next gate interval. **Reset Mode** is ignored.

Arm Control Input

Select this box to add arm input A to the block. If the arm input is high (> 0.5), the counter is turned on. If the input is low (≤ 0.5), the counter is turned off. The arm state is changed at the end of block execution and continues until the next time step.

The arm input serves as a software control for the counter, but does not latch the counter when it goes low. The block will output the most recently latched value if **HW gated latched counter** mode is also selected.

Source

Select the counter input pin. **Default Source Pin** selects the pin documented in the 6601/6602 User Manual. The **PFI** values select the input pin for other counters. The **Timebase** values select either of two different standard frequencies.

Select one of:

- **Default Source Pin**
- **PFI 39 (Pin 2)**
- **PFI 35 (Pin 7)**
- **PFI 31 (Pin 34)**
- **PFI 27 (Pin 31)**
- **PFI 23 (Pin 28)**
- **PFI 19 (Pin 25)**

- PFI 15 (Pin 22)
- PFI 11 (Pin 52)
- Timebase 1 (20 MHz)
- Timebase 2 (100 kHz)

Source Polarity

Choose the signal edge that will increment the counter. Using the fastest edge will give the most accurate count. Select one of:

- Rising Edge
- Falling Edge

Filter

Choose a filter to remove signal pulses shorter than a specified duration. High-frequency noise and slow signal edges can cause false counting. Select one of:

- None
- Synchronize input to Timebase 1 (20MHz)
- Minimum pulse width 5 microsec
- Minimum pulse width 1 microsec
- Minimum pulse width 500 nanosec
- Minimum pulse width 100 nanosec
- Minimum pulse width 25 nanosec

HW Gate Input

Select the PFI input pin to be used as gate when **Counting Mode** is set to a gated mode. **Default Gate Pin** selects the pin shown in the 6601/6602 user manual. To gate two or more counters from the same signal, select the same input for each counter. Select one of:

- Default Source Pin
- Default Gate Pin
- PFI 38 (Pin 3)
- PFI 34 (Pin 8)
- PFI 30 (Pin 67)

- PFI 26 (Pin 64)
- PFI 22 (Pin 61)
- PFI 18 (Pin 58)
- PFI 14 (Pin 21)
- PFI 10 (Pin 51)

Gate Trigger Mode

Select the trigger mode to be used when **Counting Mode** is set to a HW gated cumulative counter or HW gated latched counter. The choice of trigger edge depends on the rise time or fall time of the gate signal. Using the fastest edge will give the most accurate count. Select one of:

- Level Active High

Count source edges when the gate input is high. Latch the current count when the gate input goes from high to low and reload the counter with the reset value. The block outputs the most recently latched value.

- Level Active Low

Count source edges when the gate input is low. Latch the current count when the gate input goes from low to high and reload the counter with the reset value. The block outputs the most recently latched value.

- Rising Edge

Latch the current count on a rising edge, reload the counter with the reset value, and resume counting. The block outputs the most recently latched value.

- Falling Edge

Latch the current count on a falling edge, reload the counter with the reset value, and resume counting. The block outputs the most recently latched value.

Reset Mode

Select the reset mode to be used when **Counting Mode** is set to Cumulative counter or HW gated cumulative counter.

- No Reset

Accumulate source input edges without resetting the counter to the reset value. Sample and return the accumulated value in the counter.

- **Reset after read**

Return the accumulated value in the counter and load the counter with the reset value.

- **SW Reset**

Select this value to add reset input **R**. During block execution, the block returns the accumulated value and checks input **R**. If **R** is nonzero, the block loads the counter with the reset value.

Note:

- **Reset Mode** is ignored if **Counting Mode** is HW gated latched counter.
 - The counter value may become very large in **No Reset** mode. The value rolls over to 0 when it exceeds 0xFFFFFFFF (4294967295).
 - If **R** remains nonzero, **SW Reset** behaves like **Reset after read** mode.
-

Initial Load and Reset Value

Load the counter with this value on initial model load and again when the reset condition is met. When **Counting Mode** is HW gated latched counter, load the counter with this value when the gate turns off and latch the latest counter value for reading.

Sample time

Enter the base sample time or a multiple of the base sample time (-1 means sample time is inherited).

PCI slot (-1:autosearch)

If only one board of this type is in the target computer, enter -1 to locate the board.

If two or more boards of this type are in the target computer, enter the bus number and the PCI slot number of the board associated with this driver block. Use the format [**BusNumber,SlotNumber**].

To determine the bus number and the PCI slot number, type:

```
tg = slrt;  
getPCIInfo(tg, 'installed')
```

Examples

You can configure this block in many different ways, including:

Frequency Counter

Measures the frequency of a signal. Configure a second counter as a pulse generator and feed the pulse output to the gate input for this channel. Set the pulse generator H and L inputs to set your chosen measurement interval. Set the event counter block as follows:

Block Parameter	Value
Counting Mode	HW gated latched counter
Arm Control Input	Not checked
Source	Default Source Pin
Source Polarity	Rising Edge or Falling Edge (choose the cleaner edge)
Filter	None, or a choice faster than the signal being measured
HW Gate Input	Default Gate Pin, or some other if sharing a gate with another channel
Gate Trigger Mode	Rising Edge or Falling Edge. Because the pulse generator produces fast edges, rising and falling give the same result.
Reset Mode	Ignored

Note: If you use a **Gate Trigger Mode** of **Level Active High** or **Level Active Low** for a frequency counter, the gate must be both on and off for longer than the period of the signal being measured. If it is not on for long enough, it may not latch an edge. If it is not off for long enough, a source edge may not occur while the gate is off, the gate end condition will be missed, and the counter will add the next interval.

Events Since Last Execution

Counts the number of external binary events, such as switch closures and photocell interruptions, since the last sample time. Set the event counter block as follows:

Block Parameter	Value
Counting Mode	Cumulative counter
Arm Control Input	Checked or unchecked. If checked, use arm input A in the model to control when to accept events.
Source	Default Source Pin, or some other source pin
Source Polarity	Rising Edge or Falling Edge (choose the cleaner edge)
Filter	None, or a pulse width large enough to eliminate switch bounce and similar artifacts
HW Gate Input	Ignored
Gate Trigger Mode	Ignored
Reset Mode	Reset after read Use No Reset to create a running total of external events. Use SW Reset and reset input R to reset the count according to some condition in your model.

External Websites

- www.ni.com

National Instruments PCI/PXI-6602

Support for National Instruments PCI/PXI-6602 board

Board

National Instruments PCI/PXI-6602

General Description

The National Instruments PCI/PXI-6602 is a general-purpose counter/timer board. It has eight 32-bit counter channels. The reference frequency for this board is 80 MHz.

The Simulink Real-Time block library supports this board with the following driver block:

- National Instruments PCI/PXI-6602 Digital Input
- National Instruments PCI/PXI-6602 Digital Output
- National Instruments PCI/PXI-6602 Incremental Encoder
- National Instruments PCI/PXI-6602 Pulse Generation
- National Instruments PCI/PXI-6602 Pulse Width/Period Measurement
- National Instruments PCI/PXI-6602 Armed Pulse Generation
- National Instruments PCI/PXI-6602 Event Counter

The Simulink Real-Time software does not support the interrupt or timer functionality of the board.

Board Characteristics

Board name	PCI/PXI-6602
Manufacturer	National Instruments
Bus type	PCI/PXI
Access method	I/O mapped

Multiple block instance support	Yes
Multiple board support	Yes

External Websites

- www.ni.com

National Instruments PCI/PXI-6602 Digital Input

PCI/PXI-6602 Digital Input block

Library

Simulink Real-Time Library for National Instruments

Note

Only one input block can exist in a model for a particular board.

Block Parameters

Channel

Enter numbers between 1 and 8 to select the digital input ports. This driver allows the selection of individual digital input ports in arbitrary order. The number of elements defines the number of digital lines used.

For example, to use the first four ports as digital input channels, enter

```
[1,2,3,4]
```

Number the lines beginning with 1 even if this board manufacturer starts numbering the ports with 0.

Note: Treat the eight I/O ports as two groups of four ports. The two groups are ports 1 to 4 and ports 5 to 8. Do not specify both input and output channels in the same group of four ports. The driver will emit an error.

Sample time

Enter the base sample time or a multiple of the base sample time (-1 means sample time is inherited).

PCI slot (-1:autosearch)

If only one board of this type is in the target computer, enter - 1 to locate the board.

If two or more boards of this type are in the target computer, enter the bus number and the PCI slot number of the board associated with this driver block. Use the format **[BusNumber,SlotNumber]**.

To determine the bus number and the PCI slot number, type:

```
tg = slrt;  
getPCIInfo(tg, 'installed')
```

External Websites

- www.ni.com

National Instruments PCI/PXI-6602 Digital Output

PCI/PXI-6602 Digital Output block

Library

Simulink Real-Time Library for National Instruments

Note

Only one output block can exist in a model for a particular board.

Block Parameters

Channel

Enter numbers between 1 and 8 to select the digital output ports. This driver allows the selection of individual digital output ports in arbitrary order. The number of elements defines the number of digital lines used.

For example, to use the last four ports as digital output channels, enter

```
[5,6,7,8]
```

Number the lines beginning with 1 even if this board manufacturer starts numbering the ports with 0.

Note: Treat the eight I/O ports as two groups of four ports. The two groups are ports 1 to 4 and ports 5 to 8. Do not specify both input and output channels in the same group of four ports. The driver will emit an error.

Reset vector

The reset vector controls the behavior of the channel at model termination. Enter a scalar or a vector that is the same length as the channel vector. If you specify a scalar value, and the **Channel** parameter is longer, that value is replicated over

the channel vector. If you specify a value of 1, the corresponding channel is reset to the value specified in the initial value vector. If you specify a value of 0, the channel remains at the last value attained while the model was running.

For example, if the block parameters are set as follows:

- **Channel** — [5 6 7 8]
- **Reset vector** — [1 1 0 0]
- **Initial value vector**— [1 0 1 0]

Channels 5 and 6 will reset to the initial value vector. Channels 7 and 8 will hold at the last value attained while the model was running.

Initial value vector

The initial value vector contains the initial voltage values for the output channels. Enter a scalar or a vector that is the same length as the channel vector. If you specify a scalar value, that value is replicated over the channel vector. The channels are set to the initial values between the time the model is downloaded and the time it is started.

When execution stops, the driver writes the vector values to the output channels if the corresponding entry in the **Reset vector** is set to 1.

For example, if the block parameters are set as follows:

- **Channel** — [5 6 7 8]
- **Reset vector** — [1 1 0 0]
- **Initial value vector** — [1 0 1 0]

When the real-time application is downloaded to the target, channel 5 is set to 1, channel 6 is set to 0, channel 7 is set to 1 and channel 8 is set to 0.

After the real-time application executes, then stops, channel 5 will be set back to 1 and channel 6 will be set to 0. Channels 7 and 8 will hold the last values attained.

Sample time

Enter the base sample time or a multiple of the base sample time (-1 means sample time is inherited).

PCI slot (-1:autosearch)

If only one board of this type is in the target computer, enter -1 to locate the board.

If two or more boards of this type are in the target computer, enter the bus number and the PCI slot number of the board associated with this driver block. Use the format **[BusNumber,SlotNumber]**.

To determine the bus number and the PCI slot number, type:

```
tg = slrt;  
getPCIInfo(tg, 'installed')
```

External Websites

- www.ni.com

National Instruments PCI/PXI-6602 Incremental Encoder

PCI/PXI-6602 Incremental Encoder block

Library

Simulink Real-Time Library for National Instruments

Block Parameters

Channel

From the list, select a channel number between 1 and 8.

Number the lines beginning with 1 even if this board manufacturer starts numbering the ports with 0.

Note: If you want to attach a 3-wire encoder, do so by connecting the channel A signal to a SOURCE pin, the channel B signal to the AUX pin, and the index signal to the GATE pin.

Counting mode

From the list, select a counting mode. See the Choose one of the following:

- Normal
- Quadrature Mode X1
- Quadrature Mode X2
- Quadrature Mode X4
- Two-pulse mode
- Synchronous Source Mode

This parameter specifies the counting mode for the board. See the National Instruments PCI/PXI-6602 user manual documentation for details and definitions of these modes.

Initial count

The initial count specifies the initial value for the counter. Enter a nonnegative integer.

Reload at index pulse

Select this check box to have the count value reset to the value of **Initial count** at each index pulse.

Index phase

If the **Reload at index pulse** check box is selected, the **Index phase** parameter specifies the phase of the quadrature signals during which the count will be reloaded with **Initial count**. The count is reloaded in response to a channel index pulse. From the list, select one of the following:

- A low B low
- A low B high
- A high B low
- A high B high

Filter

You can apply a digital debouncing filter to the input pins prior to processing. From the list, select one of the following filter types:

- None
- Synchronize input to Timebase 3 (80 MHz)
- Minimum pulse width 5 microsec
- Minimum pulse width 1 microsec
- Minimum pulse width 500 nanosec
- Minimum pulse width 100 nanosec
- Minimum pulse width 25 nanosec

Sample time

Enter the base sample time or a multiple of the base sample time (- 1 means sample time is inherited).

PCI slot (-1:autosearch)

If only one board of this type is in the target computer, enter - 1 to locate the board.

If two or more boards of this type are in the target computer, enter the bus number and the PCI slot number of the board associated with this driver block. Use the format **[BusNumber,SlotNumber]**.

To determine the bus number and the PCI slot number, type:

```
tg = slrt;  
getPCIInfo(tg, 'installed')
```

External Websites

- www.ni.com

National Instruments PCI/PXI-6602 Pulse Generation

PCI/PXI-6602 Pulse Generation block

Library

Simulink Real-Time Library for National Instruments

Note

The inputs to the block are separate, one for the high count and one for the low count.

Block Parameters

Channel

From the list, choose one of the following:

- 1
- 2
- 3
- 4
- 5
- 6
- 7
- 8

These parameters specify the counter(s) to be used with this driver block. In each case, one block is required for each port.

The reference frequency for this board is 80 MHz.

Initial high count

Enter the number of clock ticks the counter should maintain for a high level.

Initial low count

Enter the number of clock ticks the counter should maintain at a low level.

Sample time

Enter the base sample time or a multiple of the base sample time (- 1 means sample time is inherited).

PCI slot (-1:autosearch)

If only one board of this type is in the target computer, enter - 1 to locate the board.

If two or more boards of this type are in the target computer, enter the bus number and the PCI slot number of the board associated with this driver block. Use the format [**BusNumber,SlotNumber**].

To determine the bus number and the PCI slot number, type:

```
tg = slrt;  
getPCIInfo(tg, 'installed')
```

External Websites

- www.ni.com

National Instruments PCI/PXI-6602 Pulse Width/Period Measurement

PCI/PXI-6602 Pulse Width/Period Measurement block

Library

Simulink Real-Time Library for National Instruments

Note

Connect the signal you want to measure to the GATE input of the chosen counter. The signal must have fast rise and fall times; otherwise, the counter might experience false triggering. Use signal voltage levels between 0 and 5 volts (TTL levels).

Block Parameters

Counter

From the list, choose one of the following:

- 1
- 2
- 3
- 4
- 5
- 6
- 7
- 8

These parameters specify the counter(s) to be used with this driver block. In each case, one block is required for each port.

Trigger mode

From the list, choose **Level Triggered** or **Edge Triggered**. See the table below for an example of how **Trigger mode** and **Polarity** interact. In this table, the data in the Output column resulted from a 1 kHz pulse train with a 25% low and a 75% high pulse.

Polarity

From the list, choose **Active low** or **Active high**. See the table below for an example of how **Trigger mode** and **Polarity** interact. In this table, the data in the Output column resulted from a 1 kHz pulse train with a 25% low and a 75% high pulse.

Measurement Objective	Trigger Mode	Polarity	Output
Pulse width (low pulse)	Level triggered	Active low	20000
Pulse width (high pulse)	Level triggered	Active high	60000
Period	Edge triggered	NA	80000

In every case, the output of the block is the number of clock ticks (of the 80 MHz source clock) required for the specified measurement. When measuring pulse width, the output reflects the number of clock ticks for which the input signal was in the specified (low or high) state. See the table above for an example.

Filter

From the list, choose one of the following:

- None
- Synchronize input to Timebase 3 (80 MHz)
- Minimum pulse width 5 microsec
- Minimum pulse width 1 microsec
- Minimum pulse width 500 nanosec
- Minimum pulse width 100 nanosec
- Minimum pulse width 25 nanosec

This parameter specifies the level of digital filtering you want to apply to the pin. See the National Instruments PCI/PXI-6602 user manual documentation for details.

Sample time

Enter the base sample time or a multiple of the base sample time (- 1 means sample time is inherited).

PCI slot (-1:autosearch)

If only one board of this type is in the target computer, enter - 1 to locate the board.

If two or more boards of this type are in the target computer, enter the bus number and the PCI slot number of the board associated with this driver block. Use the format [**BusNumber**, **SlotNumber**].

To determine the bus number and the PCI slot number, type:

```
tg = slrt;  
getPCIInfo(tg, 'installed')
```

External Websites

- www.ni.com

National Instruments PCI/PXI-6602 Armed Pulse Generation

PCI/PXI-6602 Armed Pulse Generation block

Library

Simulink Real-Time Library for National Instruments

Note

The inputs to the block are separate, one for the high count (H), one for the low count (L), and one for the arm input (A). If the arm input signal is less than 0.5, the frequency generation is disabled. If the arm input signal is greater than or equal to 0.5, the frequency generation is enabled.

Block Parameters

Channel

From the list, choose one of the following:

- 1
- 2
- 3
- 4
- 5
- 6
- 7
- 8

These parameters specify the counter to be used with this driver block. In each case, one block is required for each port.

The reference frequency for this board is 80 MHz.

Initial high count

Enter the number of clock ticks the counter should maintain for a high level.

Initial low count

Enter the number of clock ticks the counter should maintain at a low level.

Sample time

Enter the base sample time or a multiple of the base sample time (- 1 means sample time is inherited).

PCI slot (-1:autosearch)

If only one board of this type is in the target computer, enter -1 to locate the board.

If two or more boards of this type are in the target computer, enter the bus number and the PCI slot number of the board associated with this driver block. Use the format [**BusNumber,SlotNumber**].

To determine the bus number and the PCI slot number, type:

```
tg = slrt;  
getPCIInfo(tg, 'installed')
```

External Websites

- www.ni.com

National Instruments PCI/PXI-6602 Event Counter

PCI-6602 Event Counter block

Library

Simulink Real-Time Library for National Instruments

Description

The Event Counter is used for such tasks as measuring the frequency of a pulse train and counting binary events, such as switch closures and photocell interruptions (see “Examples” on page 46-429).

Block Parameters

Channel

From the list, choose one of the following:

- 1
- 2
- 3
- 4
- 5
- 6
- 7
- 8

These parameters specify the counter to be used with this driver block (channels 0 to 7). In each case, one block is required for each counter.

Counting Mode

Select one of:

- Cumulative counter

Accumulates count of edges of the source signal. Counter is reset according to **Reset Mode**. Block returns the current count without latching.

- HW gated cumulative counter

Accumulates count of edges of the source signal when the gate condition is true. Counter is reset according to **Reset Mode** (the gate end does *not* reset the count). Block returns the current count without latching.

Use **Gate Trigger Mode** values `Level Active High` or `Level Active Low` in this mode. Edge gating produces a simple cumulative counter that starts with the first edge after arming the counter.

- HW gated latched counter

Accumulates count of edges of the source signal when the gate condition is true. Gate end latches the count and resets the count to the reset value for the next gate interval. **Reset Mode** is ignored.

Arm Control Input

Select this box to add arm input A to the block. If the arm input is high (> 0.5), the counter is turned on. If the input is low (≤ 0.5), the counter is turned off. The arm state is changed at the end of block execution and continues until the next time step.

The arm input serves as a software control for the counter, but does not latch the counter when it goes low. The block will output the most recently latched value if `HW gated latched counter` mode is also selected.

Source

Select the counter input pin. `Default Source Pin` selects the pin documented in the 6601/6602 User Manual. The `PFI` values select the input pin for other counters. The `Timebase` values select one of three different standard frequencies.

- `Default Source Pin`
- `PFI 39 (Pin 2)`
- `PFI 35 (Pin 7)`
- `PFI 31 (Pin 34)`
- `PFI 27 (Pin 31)`
- `PFI 23 (Pin 28)`

- PFI 19 (Pin 25)
- PFI 15 (Pin 22)
- PFI 11 (Pin 52)
- Timebase 1 (20.0 MHz)
- Timebase 2 (100 kHz)
- Timebase 3 (80 MHz)

Source Polarity

Choose the signal edge that will increment the counter. Using the fastest edge will give the most accurate count. Select one of:

- Rising Edge
- Falling Edge

Filter

Choose a filter to remove signal pulses shorter than a specified duration. High-frequency noise and slow signal edges can cause false counting. Select one of:

- None
- Synchronize input to Timebase 1 (20MHz)
- Minimum pulse width 5 microsec
- Minimum pulse width 1 microsec
- Minimum pulse width 500 nanosec
- Minimum pulse width 100 nanosec
- Minimum pulse width 25 nanosec

HW Gate Input

Select the PFI input pin to be used as gate when **Counting Mode** is set to a gated mode. **Default Gate Pin** selects the pin shown in the 6601/6602 user manual. To gate two or more counters from the same signal, select the same input for each counter. Select one of:

- Default Source Pin
- Default Gate Pin
- PFI 38 (Pin 3)

- PFI 34 (Pin 8)
- PFI 30 (Pin 67)
- PFI 26 (Pin 64)
- PFI 22 (Pin 61)
- PFI 18 (Pin 58)
- PFI 14 (Pin 21)
- PFI 10 (Pin 51)

Gate Trigger Mode

Select the trigger mode to be used when **Counting Mode** is set to a **HW gated cumulative counter** or **HW gated latched counter**. The choice of trigger edge depends on the rise time or fall time of the gate signal. Using the fastest edge will give the most accurate count. Select one of:

- Level Active High

Count source edges when the gate input is high. Latch the current count when the gate input goes from high to low and reload the counter with the reset value. The block outputs the most recently latched value.

- Level Active Low

Count source edges when the gate input is low. Latch the current count when the gate input goes from low to high and reload the counter with the reset value. The block outputs the most recently latched value.

- Rising Edge

Latch the current count on a rising edge, reload the counter with the reset value, and resume counting. The block outputs the most recently latched value.

- Falling Edge

Latch the current count on a falling edge, reload the counter with the reset value, and resume counting. The block outputs the most recently latched value.

Reset Mode

Select the reset mode to be used when **Counting Mode** is set to **Cumulative counter** or **HW gated cumulative counter**.

- No Reset

Accumulate source input edges without resetting the counter to the reset value. Sample and return the accumulated value in the counter.

- **Reset after read**

Return the accumulated value in the counter and load the counter with the reset value.

- **SW Reset**

Select this value to add reset input R. During block execution, the block returns the accumulated value and checks input R. If R is nonzero, the block loads the counter with the reset value.

Reset Mode is ignored if **Counting Mode** is HW gated latched counter.

The counter value may become very large in **No Reset** mode. The value rolls over to 0 when it exceeds 0xFFFFFFFF (4294967295).

If R remains nonzero, **SW Reset** behaves like **Reset after read** mode.

Initial Load and Reset Value

Load the counter with this value on initial model load and again when the reset condition is met. When **Counting Mode** is HW gated latched counter, load the counter with this value when the gate turns off and latch the latest counter value for reading.

Sample time

Enter the base sample time or a multiple of the base sample time (-1 means sample time is inherited).

PCI slot (-1:autosearch)

If only one board of this type is in the target computer, enter -1 to locate the board.

If two or more boards of this type are in the target computer, enter the bus number and the PCI slot number of the board associated with this driver block. Use the format **[BusNumber,SlotNumber]**.

To determine the bus number and the PCI slot number, type:

```
tg = slrt;  
getPCIInfo(tg, 'installed')
```

Examples

You can configure this block in many different ways, including:

Frequency Counter

Measures the frequency of a signal. Configure a second counter as a pulse generator and feed the pulse output to the gate input for this channel. Set the pulse generator H and L inputs to set your chosen measurement interval. Set the event counter block as follows:

Block Parameter	Value
Counting Mode	HW gated latched counter
Arm Control Input	Not checked
Source	Default Source Pin
Source Polarity	Rising Edge or Falling Edge (choose the cleaner edge)
Filter	None, or a choice faster than the signal being measured
HW Gate Input	Default Gate Pin, or some other if sharing a gate with another channel
Gate Trigger Mode	Rising Edge or Falling Edge. Because the pulse generator produces fast edges, rising and falling give the same result.
Reset Mode	Ignored

If you use a **Gate Trigger Mode** of **Level Active High** or **Level Active Low** for a frequency counter, the gate must be both on and off for longer than the period of the signal being measured. If it is not on for long enough, it may not latch an edge. If it is not off for long enough, a source edge may not occur while the gate is off, the gate end condition will be missed, and the counter will add the next interval.

Events Since Last Execution

Counts the number of external binary events, such as switch closures and photocell interruptions, since the last sample time. Set the event counter block as follows:

Block Parameter	Value
Counting Mode	Cumulative counter
Arm Control Input	Checked or unchecked. If checked, use arm input A in the model to control when to accept events.
Source	Default Source Pin, or some other source pin
Source Polarity	Rising Edge or Falling Edge (choose the cleaner edge)
Filter	None, or a pulse width required to eliminate switch bounce and similar artifacts
HW Gate Input	Ignored
Gate Trigger Mode	Ignored
Reset Mode	Reset after read Use No Reset to create a running total of external events. Use SW Reset and reset input R to reset the count according to some condition in your model.

More About

- “National Instruments Troubleshooting” on page 45-2

External Websites

- www.ni.com

National Instruments PCI-6703

Support for National Instruments PCI-6703 board

Board

National Instruments PCI-6703

General Description

The PCI-6703 is an I/O board with 16 voltage outputs and 8 digital I/O lines.

The Simulink Real-Time block library supports this board with this driver block:

- National Instruments PCI-6703 Analog Output (D/A)

Simulink Real-Time does not support the 8 digital I/O lines.

You will notice a variable delay in the voltage output from the board after your real-time application writes the register on the board. This is because the PCI-6703 has a single D/A converter that is time-share multiplexed through the outputs. It can take up to 0.9 milliseconds to scan through the channels.

Board Characteristics

Board name	PCI-6703
Manufacturer	National Instruments
Bus type	PCI
Access method	Memory mapped
Multiple block instance support	No
Multiple board support	Yes

External Websites

- www.ni.com

National Instruments PCI-6703 Analog Output (D/A)

PCI-6703 Analog Output block

Library

Simulink Real-Time Library for National Instruments

Scaling Input to Output

I/O Module Output	Block Input Data Type	Scaling
Volts	Double	1

Block Parameters

Channel vector

Enter numbers between 1 and 16. This driver allows the selection of individual D/A channels in arbitrary order. The number of elements defines the number of D/A channels used. For example, to use the first and second analog output (D/A) channels, enter

```
[1,2]
```

Number the channels beginning with 1 even if this board manufacturer starts numbering the channels with 0.

Sample time

Enter the base sample time or a multiple of the base sample time (-1 means sample time is inherited).

PCI slot (-1:autosearch)

If only one board of this type is in the target computer, enter -1 to locate the board.

If two or more boards of this type are in the target computer, enter the bus number and the PCI slot number of the board associated with this driver block. Use the format **[BusNumber,SlotNumber]**.

To determine the bus number and the PCI slot number, type:

```
tg = slrt;  
getPCIInfo(tg, 'installed')
```

External Websites

- www.ni.com

National Instruments PCI-6704

Support for National Instruments PCI-6704 board

Board

National Instruments PCI-6704

General Description

The PCI-6704 is an I/O board with 16 voltage outputs, 16 current outputs, and 8 digital I/O lines.

The Simulink Real-Time block library supports this board with this driver block:

- National Instruments PCI-6704 Analog Output (D/A)

You will notice a variable delay in the voltage output from the board after your real-time application writes the register on the board. This is because the PCI-6704 has a single D/A converter that is time-share multiplexed through the outputs. It can take up to 1.8 milliseconds to scan through the channels.

Board Characteristics

Board name	PCI-6704
Manufacturer	National Instruments
Bus type	PCI
Access method	Memory mapped
Multiple block instance support	No
Multiple board support	Yes

External Websites

- www.ni.com

National Instruments PCI-6704 Analog Output (D/A)

PCI-6704 Analog Output block

Library

Simulink Real-Time Library for National Instruments

Scaling Input to Output

I/O Module Output	Block Input Data Type	Scaling
Volts — Channels 1 to 16	Double	-10 V to 10 V
Milliamperes — Channels 17 to 32	Double	0 mA to 20 mA

Block Parameters

Channel vector

Enter numbers between 1 and 32. Channels 1-16 refer to the voltage output channels, and 17-32 the current output channels. This driver allows the selection of individual D/A channels in arbitrary order. The number of elements defines the number of D/A channels used. For example, to use the first and second analog output (D/A) channels, enter

```
[1,2]
```

Number the channels beginning with 1 even if this board manufacturer starts numbering the channels with 0.

Sample time

Enter the base sample time or a multiple of the base sample time (-1 means sample time is inherited).

PCI slot (-1:autosearch)

If only one board of this type is in the target computer, enter -1 to locate the board.

If two or more boards of this type are in the target computer, enter the bus number and the PCI slot number of the board associated with this driver block. Use the format **[BusNumber,SlotNumber]**.

To determine the bus number and the PCI slot number, type:

```
tg = slrt;  
getPCIInfo(tg, 'installed')
```

External Websites

- www.ni.com

National Instruments PCI/PXI-6711

Support for National Instruments PCI/PXI-6711 board

Board

National Instruments PCI/PXI-6711

General Description

The PCI/PXI-6711 is an analog output board with four analog output (D/A) channels (12-bit), eight digital input and output lines, and two 24-bit, 20 MHz counters/timers.

The Simulink Real-Time block library supports this board with these driver blocks:

- National Instruments PCI/PXI-6711 Analog Output (D/A)
- National Instruments PCI/PXI-6711 Digital Input
- National Instruments PCI/PXI-6711 Digital Output
- National Instruments PCI/PXI-6711 Pulse Generation
- National Instruments PCI/PXI-6711 Pulse Width/Period Measurement

Board Characteristics

Board name	PCI/PXI-6711
Manufacturer	National Instruments
Bus type	PCI/PXI
Multiple block instance support	D/A: No, Digital I/O: Yes
Multiple board support	Yes

External Websites

- www.ni.com

National Instruments PCI/PXI-6711 Analog Output (D/A)

PCI/PXI-6711 Analog Output block

Library

Simulink Real-Time Library for National Instruments

Note

The analog output range of this board is set -10 to +10 volts.

Scaling Input to Output

I/O Module Output	Block Input Data Type	Scaling
Volts	Double	1

Block Parameters

Channel vector

Enter numbers between 1 and 4. This driver allows the selection of individual D/A channels in arbitrary order. The number of elements defines the number of D/A channels used. For example, to use the analog output channels 1 and 2, enter

[1,2]

Number the channels beginning with 1 even if this board manufacturer starts numbering the channels with 0.

Reset vector

The reset vector controls the behavior of the channel at model termination. Enter a scalar or a vector that is the same length as the channel vector. If you specify a scalar

value, that setting is replicated over the channel vector. If you specify a value of 1, the corresponding channel is reset to the value specified in the initial value vector. If you specify a value of 0, the channel remains at the last value attained while the model was running.

Initial value vector

The initial value vector contains the initial voltage values for the output channels. Enter a scalar or a vector that is the same length as the channel vector. If you specify a scalar value, that value is replicated as the initial value over the channel vector. The channels are set to the initial values between the time the model is downloaded and the time it is started.

Sample time

Enter the base sample time or a multiple of the base sample time (- 1 means sample time is inherited).

PCI slot (-1:autosearch)

If only one board of this type is in the target computer, enter - 1 to locate the board.

If two or more boards of this type are in the target computer, enter the bus number and the PCI slot number of the board associated with this driver block. Use the format **[BusNumber, SlotNumber]**.

To determine the bus number and the PCI slot number, type:

```
tg = slrt;  
getPCIInfo(tg, 'installed')
```

External Websites

- www.ni.com

National Instruments PCI/PXI-6711 Digital Input

PCI/PXI-6711 Digital Input block

Library

Simulink Real-Time Library for National Instruments

Scaling Input to Output

I/O Module Input	Block Output Data Type	Scaling
TTL	Double	TTL low = 0.0 TTL high = 1.0

Block Parameters

Channel vector

Enter numbers between 1 and 8 to select the digital input lines used with this block. This driver allows the selection of individual digital input lines in arbitrary order. The number of elements defines the number of digital lines used.

For example, to use all of the digital inputs with this block, enter

```
[1,2,3,4,5,6,7,8]
```

Each line can be used for input or output. If a line is not listed in this field, a digital output block using the same board can use that line.

Number the lines beginning with 1 even if this board manufacturer starts numbering the lines with 0.

Sample time

Enter the base sample time or a multiple of the base sample time (-1 means sample time is inherited).

PCI slot (-1:autosearch)

If only one board of this type is in the target computer, enter -1 to locate the board.

If two or more boards of this type are in the target computer, enter the bus number and the PCI slot number of the board associated with this driver block. Use the format **[BusNumber,SlotNumber]**.

To determine the bus number and the PCI slot number, type:

```
tg = slrt;  
getPCIInfo(tg, 'installed')
```

External Websites

- www.ni.com

National Instruments PCI/PXI-6711 Digital Output

PCI/PXI-6711 Digital Output

Library

Simulink Real-Time Library for National Instruments

Scaling Input to Output

I/O Module Output	Block Input Data Type	Scaling
TTL	Double	$< 0.5 = \text{TTL low}$ $\geq 0.5 = \text{TTL high}$

Block Parameters

Channel vector

Enter numbers between 1 and 8 to select the digital output lines used with this block. This driver allows the selection of individual digital output lines in arbitrary order. The number of elements defines the number of digital lines used.

For example, to use all of the digital outputs with this block, enter

```
[1,2,3,4,5,6,7,8]
```

Each line can be used for input or output. If a line is not listed in this field, a digital input block using the same board can use that line.

Number the lines beginning with 1 even if this board manufacturer starts numbering the lines with 0.

Reset vector

The reset vector controls the behavior of the channel at model termination. Enter a scalar or a vector that is the same length as the channel vector. If you specify a scalar value, that setting is replicated over the channel vector. If you specify a value of 1, the corresponding channel is reset to the value specified in the initial value vector.

If you specify a value of 0, the channel remains at the last value attained while the model was running.

Initial value vector

The initial value vector contains the initial values (0 or 1) of the output channels. Enter a scalar or a vector that is the same length as the channel vector. If you enter a scalar, that value is replicated as the initial value over the channel vector. The channels are set to these initial values between the time the model is downloaded and the time it is started.

Sample time

Enter the base sample time or a multiple of the base sample time (- 1 means sample time is inherited).

PCI slot (-1:autosearch)

If only one board of this type is in the target computer, enter - 1 to locate the board.

If two or more boards of this type are in the target computer, enter the bus number and the PCI slot number of the board associated with this driver block. Use the format **[BusNumber, SlotNumber]**.

To determine the bus number and the PCI slot number, type:

```
tg = slrt;  
getPCIInfo(tg, 'installed')
```

External Websites

- www.ni.com

National Instruments PCI/PXI-6711 Pulse Generation

PCI/PXI-6711 Pulse Generation block

Library

Simulink Real-Time Library for National Instruments

Note

The inputs to the block should be a two-element vector. The first element is the number of counts (of the 20 MHz source clock) that the counter should maintain at a low level, and the second element is the number of clock ticks for a high level. For example, to generate a pulse train at 1 kHz with 25% low and 75% high, use the vector

```
[5000 15000]
```

Block Parameters

Counter

From the list, choose **Counter 0**, **Counter 1**, or **Both** to select the counter(s) to be used with this driver block. In each case, one block is required for each physical board.

Sample time

Enter the base sample time or a multiple of the base sample time (-1 means sample time is inherited).

PCI slot (-1:autosearch)

If only one board of this type is in the target computer, enter -1 to locate the board.

If two or more boards of this type are in the target computer, enter the bus number and the PCI slot number of the board associated with this driver block. Use the format **[BusNumber, SlotNumber]**.

To determine the bus number and the PCI slot number, type:

```
tg = slrt;  
getPCIInfo(tg, 'installed')
```

External Websites

- www.ni.com

National Instruments PCI/PXI-6711 Pulse Width/Period Measurement

PCI/PXI-6711 Pulse Width/Period Measurement block

Library

Simulink Real-Time Library for National Instruments

Block Parameters

Counter

From the list, select a counter, 0 or 1.

Trigger mode

From the list, choose **Level Triggered** or **Edge Triggered**. See the table below for an example of how **Trigger mode** and **Polarity** interact. In this table, the data in the Output column resulted from a 1 kHz pulse train with a 25% low and a 75% high pulse.

Polarity

From the list, choose **Active low** or **Active high**. See the table below for an example of how **Trigger mode** and **Polarity** interact. In this table, the data in the Output column resulted from a 1 kHz pulse train with a 25% low and a 75% high pulse.

Measurement Objective	Trigger Mode	Polarity	Output
Pulse width (low pulse)	Level triggered	Active low	5000
Pulse width (high pulse)	Level triggered	Active high	15000
Period	Edge triggered	NA	20000

In every case, the output of the block is the number of clock ticks (of the 20 MHz source clock) required for the specified measurement. When measuring pulse width,

the output reflects the number of clock ticks for which the input signal was in the specified (low or high) state. See the table above for an example.

Sample time

Enter the base sample time or a multiple of the base sample time (- 1 means sample time is inherited).

PCI slot (-1:autosearch)

If only one board of this type is in the target computer, enter - 1 to locate the board.

If two or more boards of this type are in the target computer, enter the bus number and the PCI slot number of the board associated with this driver block. Use the format **[BusNumber,SlotNumber]**.

To determine the bus number and the PCI slot number, type:

```
tg = slrt;  
getPCIInfo(tg, 'installed')
```

External Websites

- www.ni.com

National Instruments PCI/PXI-6713

Support for National Instruments PCI/PXI-6713 board

Board

National Instruments PCI/PXI-6713

General Description

The PCI/PXI-6713 is an analog output board with eight analog output (D/A) channels (12-bit), eight digital input and output lines, and two 24-bit, 20 MHz counters/timers.

The Simulink Real-Time block library supports this board with these driver blocks:

- National Instruments PCI/PXI-6713 Analog Output (D/A)
- National Instruments PCI/PXI-6713 Digital Input
- National Instruments PCI/PXI-6713 Digital Output
- National Instruments PCI/PXI-6713 Pulse Generation
- National Instruments PCI/PXI-6713 Pulse Width/Period Measurement

Board Characteristics

Board name	PCI/PXI-6713
Manufacturer	National Instruments
Bus type	PCI/PXI
Multiple block instance support	D/A: No, Digital I/O: Yes
Multiple board support	Yes

External Websites

- www.ni.com

National Instruments PCI/PXI-6713 Analog Output (D/A)

PCI/PXI-6713 Analog Output block

Library

Simulink Real-Time Library for National Instruments

Note

The analog output range of this board is set -10 to +10 volts.

Scaling Input to Output

I/O Module Output	Block Input Data Type	Scaling
Volts	Double	1

Block Parameters

Channel vector

Enter numbers between 1 and 8. This driver allows the selection of individual D/A channels in arbitrary order. The number of elements defines the number of D/A channels used. For example, to use the analog output channels 1 and 2, enter

[1,2]

Number the channels beginning with 1 even if this board manufacturer starts numbering the channels with 0.

Reset vector

The reset vector controls the behavior of the channel at model termination. Enter a scalar or a vector that is the same length as the channel vector. If you specify a scalar

value, that setting is replicated over the channel vector. If you specify a value of 1, the corresponding channel is reset to the value specified in the initial value vector. If you specify a value of 0, the channel remains at the last value attained while the model was running.

Initial value vector

The initial value vector contains the initial voltage values for the output channels. Enter a scalar or a vector that is the same length as the channel vector. If you specify a scalar value, that value is replicated as the initial value over the channel vector. The channels are set to the initial values between the time the model is downloaded and the time it is started.

Sample time

Enter the base sample time or a multiple of the base sample time (- 1 means sample time is inherited).

PCI slot (-1:autosearch)

If only one board of this type is in the target computer, enter - 1 to locate the board.

If two or more boards of this type are in the target computer, enter the bus number and the PCI slot number of the board associated with this driver block. Use the format **[BusNumber, SlotNumber]**.

To determine the bus number and the PCI slot number, type:

```
tg = slrt;  
getPCIInfo(tg, 'installed')
```

External Websites

- www.ni.com

National Instruments PCI/PXI-6713 Digital Input

PCI/PXI-6713 Digital Input

Library

Simulink Real-Time Library for National Instruments

Scaling Input to Output

I/O Module Input	Block Output Data Type	Scaling
TTL	Double	TTL low = 0.0 TTL high = 1.0

Block Parameters

Channel vector

Enter numbers between 1 and 8 to select the digital input lines used with this block. This driver allows the selection of individual digital input lines in arbitrary order. The number of elements defines the number of digital lines used.

For example, to use all of the digital inputs with this block, enter

```
[1,2,3,4,5,6,7,8]
```

Each line can be used for input or output. If a line is not listed in this field, a digital output block using the same board can use that line.

Number the lines beginning with 1 even if this board manufacturer starts numbering the lines with 0.

Sample time

Enter the base sample time or a multiple of the base sample time (-1 means sample time is inherited).

PCI slot (-1:autosearch)

If only one board of this type is in the target computer, enter - 1 to locate the board.

If two or more boards of this type are in the target computer, enter the bus number and the PCI slot number of the board associated with this driver block. Use the format **[BusNumber,SlotNumber]**.

To determine the bus number and the PCI slot number, type:

```
tg = slrt;  
getPCIInfo(tg, 'installed')
```

External Websites

- www.ni.com

National Instruments PCI/PXI-6713 Digital Output

PCI/PXI-6713 Digital Output block

Library

Simulink Real-Time Library for National Instruments

Scaling Input to Output

I/O Module Output	Block Input Data Type	Scaling
TTL	Double	$< 0.5 = \text{TTL low}$ $\geq 0.5 = \text{TTL high}$

Block Parameters

Channel vector

Enter numbers between 1 and 8 to select the digital output lines used with this block. This driver allows the selection of individual digital output lines in arbitrary order. The number of elements defines the number of digital lines used.

For example, to use all of the digital outputs for with this block, enter

```
[1,2,3,4,5,6,7,8]
```

Each line can be used for input or output. If a line is not listed in this field, a digital input block using the same board can use that line.

Number the lines beginning with 1 even if this board manufacturer starts numbering the lines with 0.

Reset vector

The reset vector controls the behavior of the channel at model termination. Enter a scalar or a vector that is the same length as the channel vector. If you specify a scalar value, that setting is replicated over the channel vector. If you specify a value of 1, the corresponding channel is reset to the value specified in the initial value vector.

If you specify a value of 0, the channel remains at the last value attained while the model was running.

Initial value vector

The initial value vector contains the initial values (0 or 1) of the output channels. Enter a scalar or a vector that is the same length as the channel vector. If you enter a scalar, that value is replicated as the initial value over the channel vector. The channels are set to these initial values between the time the model is downloaded and the time it is started.

Sample time

Enter the base sample time or a multiple of the base sample time (- 1 means sample time is inherited).

PCI slot (-1:autosearch)

If only one board of this type is in the target computer, enter - 1 to locate the board.

If two or more boards of this type are in the target computer, enter the bus number and the PCI slot number of the board associated with this driver block. Use the format **[BusNumber, SlotNumber]**.

To determine the bus number and the PCI slot number, type:

```
tg = slrt;  
getPCIInfo(tg, 'installed')
```

External Websites

- www.ni.com

National Instruments PCI/PXI-6713 Pulse Generation

PCI/PXI-6713 Pulse Generation block

Library

Simulink Real-Time Library for National Instruments

Note

The inputs to the block should be a two-element vector. The first element is the number of counts (of the 20 MHz source clock) that the counter should maintain at a low level, and the second element is the number of clock ticks for a high level. For example, to generate a pulse train at 1 kHz with 25% low and 75% high, use the vector

```
[5000 15000]
```

Block Parameters

Counter

From the list, choose **Counter 0**, **Counter 1**, or **Both** to select the counter(s) to be used with this driver block. In each case, one block is required for each physical board.

Sample time

Enter the base sample time or a multiple of the base sample time (- 1 means sample time is inherited).

PCI slot (-1:autosearch)

If only one board of this type is in the target computer, enter - 1 to locate the board.

If two or more boards of this type are in the target computer, enter the bus number and the PCI slot number of the board associated with this driver block. Use the format **[BusNumber, SlotNumber]**.

To determine the bus number and the PCI slot number, type:

```
tg = slrt;  
getPCIInfo(tg, 'installed')
```

External Websites

- www.ni.com

National Instruments PCI/PXI-6713 Pulse Width/Period Measurement

PCI/PXI-6713 Pulse Width/Period Measurement block

Library

Simulink Real-Time Library for National Instruments

Block Parameters

Counter

From the list, select a counter, 0 or 1.

Trigger mode

From the list, choose **Level Triggered** or **Edge Triggered**. See the table below for an example of how **Trigger mode** and **Polarity** interact. In this table, the data in the Output column resulted from a 1 kHz pulse train with a 25% low and a 75% high pulse.

Polarity

From the list, choose **Active low** or **Active high**. See the table below for an example of how **Trigger mode** and **Polarity** interact. In this table, the data in the Output column resulted from a 1 kHz pulse train with a 25% low and a 75% high pulse.

Measurement Objective	Trigger Mode	Polarity	Output
Pulse width (low pulse)	Level triggered	Active low	5000
Pulse width (high pulse)	Level triggered	Active high	15000
Period	Edge triggered	NA	20000

In every case, the output of the block is the number of clock ticks (of the 20 MHz source clock) required for the specified measurement. When measuring pulse width,

the output reflects the number of clock ticks for which the input signal was in the specified (low or high) state. See the table above for an example.

Sample time

Enter the base sample time or a multiple of the base sample time (- 1 means sample time is inherited).

PCI slot (-1:autosearch)

If only one board of this type is in the target computer, enter - 1 to locate the board.

If two or more boards of this type are in the target computer, enter the bus number and the PCI slot number of the board associated with this driver block. Use the format **[BusNumber,SlotNumber]**.

To determine the bus number and the PCI slot number, type:

```
tg = slrt;  
getPCIInfo(tg, 'installed')
```

External Websites

- www.ni.com

National Instruments PCI/PXI-6731

Support for National Instruments PCI/PXI-6731 board

Board

National Instruments PCI/PXI-6731

General Description

The PCI/PXI-6731 is an analog output board with four analog output (D/A) channels (16-bit), eight digital input and output lines, and two 24-bit, 20 MHz counters/timers.

The Simulink Real-Time block library supports this board with these driver blocks:

- National Instruments PCI/PXI-6731 Analog Output (D/A)
- National Instruments PCI/PXI-6731 Digital Input
- National Instruments PCI/PXI-6731 Digital Output
- National Instruments PCI/PXI-6731 Pulse Generation
- National Instruments PCI/PXI-6731 Pulse Width/Period Measurement

Board Characteristics

Board name	PCI/PXI-6731
Manufacturer	National Instruments
Bus type	PCI/PXI
Multiple block instance support	D/A: No, Digital I/O: Yes
Multiple board support	Yes

External Websites

- www.ni.com

National Instruments PCI/PXI-6731 Analog Output (D/A)

PCI/PXI-6731 Analog Output block

Library

Simulink Real-Time Library for National Instruments

Note

The analog output range of this board is set -10 to +10 volts.

Scaling Input to Output

I/O Module Output	Block Input Data Type	Scaling
Volts	Double	1

Block Parameters

Channel vector

Enter numbers between 1 and 4. This driver allows the selection of individual D/A channels in arbitrary order. The number of elements defines the number of D/A channels used. For example, to use the analog output channels 1 and 2, enter

[1,2]

Number the channels beginning with 1 even if this board manufacturer starts numbering the channels with 0.

Reset vector

The reset vector controls the behavior of the channel at model termination. Enter a scalar or a vector that is the same length as the channel vector. If you specify a scalar

value, that setting is replicated over the channel vector. If you specify a value of 1, the corresponding channel is reset to the value specified in the initial value vector. If you specify a value of 0, the channel remains at the last value attained while the model was running.

Initial value vector

The initial value vector contains the initial voltage values for the output channels. Enter a scalar or a vector that is the same length as the channel vector. If you specify a scalar value, that value is replicated as the initial value over the channel vector. The channels are set to the initial values between the time the model is downloaded and the time it is started.

Sample time

Enter the base sample time or a multiple of the base sample time (- 1 means sample time is inherited).

PCI slot (-1:autosearch)

If only one board of this type is in the target computer, enter - 1 to locate the board.

If two or more boards of this type are in the target computer, enter the bus number and the PCI slot number of the board associated with this driver block. Use the format **[BusNumber, SlotNumber]**.

To determine the bus number and the PCI slot number, type:

```
tg = slrt;  
getPCIInfo(tg, 'installed')
```

External Websites

- www.ni.com

National Instruments PCI/PXI-6731 Digital Input

PCI/PXI-6731 Digital Input block

Library

Simulink Real-Time Library for National Instruments

Scaling Input to Output

I/O Module Input	Block Output Data Type	Scaling
TTL	Double	TTL low = 0.0 TTL high = 1.0

Block Parameters

Channel vector

Enter numbers between 1 and 8 to select the digital input lines used with this block. This driver allows the selection of individual digital input lines in arbitrary order. The number of elements defines the number of digital lines used.

For example, to use all of the digital inputs with this block, enter

```
[1,2,3,4,5,6,7,8]
```

Each line can be used for input or output. If a line is not listed in this field, a digital output block using the same board can use that line.

Number the lines beginning with 1 even if this board manufacturer starts numbering the lines with 0.

Sample time

Enter the base sample time or a multiple of the base sample time (-1 means sample time is inherited).

PCI slot (-1:autosearch)

If only one board of this type is in the target computer, enter -1 to locate the board.

If two or more boards of this type are in the target computer, enter the bus number and the PCI slot number of the board associated with this driver block. Use the format **[BusNumber, SlotNumber]**.

To determine the bus number and the PCI slot number, type:

```
tg = slrt;  
getPCIInfo(tg, 'installed')
```

External Websites

- www.ni.com

National Instruments PCI/PXI-6731 Digital Output

PCI/PXI-6731 Digital Output

Library

Simulink Real-Time Library for National Instruments

Scaling Input to Output

I/O Module Output	Block Input Data Type	Scaling
TTL	Double	$< 0.5 = \text{TTL low}$ $\geq 0.5 = \text{TTL high}$

Block Parameters

Channel vector

Enter numbers between 1 and 8 to select the digital output lines used with this block. This driver allows the selection of individual digital output lines in arbitrary order. The number of elements defines the number of digital lines used.

For example, to use all of the digital outputs with this block, enter

```
[1,2,3,4,5,6,7,8]
```

Each line can be used for input or output. If a line is not listed in this field, a digital input block using the same board can use that line.

Number the lines beginning with 1 even if this board manufacturer starts numbering the lines with 0.

Reset vector

The reset vector controls the behavior of the channel at model termination. Enter a scalar or a vector that is the same length as the channel vector. If you specify a scalar value, that setting is replicated over the channel vector. If you specify a value of 1, the corresponding channel is reset to the value specified in the initial value vector.

If you specify a value of 0, the channel remains at the last value attained while the model was running.

Initial value vector

The initial value vector contains the initial values (0 or 1) of the output channels. Enter a scalar or a vector that is the same length as the channel vector. If you enter a scalar, that value is replicated as the initial value over the channel vector. The channels are set to these initial values between the time the model is downloaded and the time it is started.

Sample time

Enter the base sample time or a multiple of the base sample time (- 1 means sample time is inherited).

PCI slot (-1:autosearch)

If only one board of this type is in the target computer, enter - 1 to locate the board.

If two or more boards of this type are in the target computer, enter the bus number and the PCI slot number of the board associated with this driver block. Use the format **[BusNumber, SlotNumber]**.

To determine the bus number and the PCI slot number, type:

```
tg = slrt;  
getPCIInfo(tg, 'installed')
```

External Websites

- www.ni.com

National Instruments PCI/PXI-6731 Pulse Generation

PCI/PXI-6731 Pulse Generation block

Library

Simulink Real-Time Library for National Instruments

Note

The inputs to the block should be a two-element vector. The first element is the number of counts (of the 20 MHz source clock) that the counter should maintain at a low level, and the second element is the number of clock ticks for a high level. For example, to generate a pulse train at 1 kHz with 25% low and 75% high, use the vector

```
[5000 15000]
```

Block Parameters

Counter

From the list, choose **Counter 0**, **Counter 1**, or **Both** to select the counter(s) to be used with this driver block. In each case, one block is required for each physical board.

Sample time

Enter the base sample time or a multiple of the base sample time (-1 means sample time is inherited).

PCI slot (-1:autosearch)

If only one board of this type is in the target computer, enter -1 to locate the board.

If two or more boards of this type are in the target computer, enter the bus number and the PCI slot number of the board associated with this driver block. Use the format **[BusNumber, SlotNumber]**.

To determine the bus number and the PCI slot number, type:

```
tg = slrt;  
getPCIInfo(tg, 'installed')
```

External Websites

- www.ni.com

National Instruments PCI/PXI-6731 Pulse Width/Period Measurement

PCI/PXI-6731 Pulse Width/Period Measurement block

Library

Simulink Real-Time Library for National Instruments

Block Parameters

Counter

From the list, select a counter, 0 or 1.

Trigger mode

From the list, choose **Level Triggered** or **Edge Triggered**. See the table below for an example of how **Trigger mode** and **Polarity** interact. In this table, the data in the Output column resulted from a 1 kHz pulse train with a 25% low and a 75% high pulse.

Polarity

From the list, choose **Active low** or **Active high**. See the table below for an example of how **Trigger mode** and **Polarity** interact. In this table, the data in the Output column resulted from a 1 kHz pulse train with a 25% low and a 75% high pulse.

Measurement Objective	Trigger Mode	Polarity	Output
Pulse width (low pulse)	Level triggered	Active low	5000
Pulse width (high pulse)	Level triggered	Active high	15000
Period	Edge triggered	NA	20000

In every case, the output of the block is the number of clock ticks (of the 20 MHz source clock) required for the specified measurement. When measuring pulse width,

the output reflects the number of clock ticks for which the input signal was in the specified (low or high) state. See the table above for an example.

Sample time

Enter the base sample time or a multiple of the base sample time (- 1 means sample time is inherited).

PCI slot (-1:autosearch)

If only one board of this type is in the target computer, enter - 1 to locate the board.

If two or more boards of this type are in the target computer, enter the bus number and the PCI slot number of the board associated with this driver block. Use the format **[BusNumber,SlotNumber]**.

To determine the bus number and the PCI slot number, type:

```
tg = slrt;  
getPCIInfo(tg, 'installed')
```

External Websites

- www.ni.com

National Instruments PCI/PXI-6733

Support for National Instruments PCI/PXI-6733 board

Board

National Instruments PCI/PXI-6733

General Description

The PCI/PXI-6733 is an analog output board with eight analog output (D/A) channels (16-bit), eight digital input and output lines, and two 24-bit counters.

The Simulink Real-Time block library supports this board with these driver blocks:

- National Instruments PCI/PXI-6733 Analog Output (D/A)
- National Instruments PCI/PXI-6733 Digital Input
- National Instruments PCI/PXI-6733 Digital Output
- National Instruments PCI/PXI-6733 Pulse Generation
- National Instruments PCI/PXI-6733 Pulse Width/Period Measurement

Board Characteristics

Board name	PCI/PXI-6733
Manufacturer	National Instruments
Bus type	PCI/PXI
Multiple block instance support	D/A: No, Digital I/O: Yes
Multiple board support	Yes

External Websites

- www.ni.com

National Instruments PCI/PXI-6733 Analog Output (D/A)

PCI/PXI-6733 Analog Output block

Library

Simulink Real-Time Library for National Instruments

Note

The analog output range of this board is set -10 to +10 volts.

Scaling Input to Output

I/O Module Output	Block Input Data Type	Scaling
Volts	Double	1

Block Parameters

Channel vector

Enter numbers between 1 and 8. This driver allows the selection of individual D/A channels in arbitrary order. The number of elements defines the number of D/A channels used. For example, to use the analog output channels 1 and 2, enter

[1,2]

Number the channels beginning with 1 even if this board manufacturer starts numbering the channels with 0.

Reset vector

The reset vector controls the behavior of the channel at model termination. Enter a scalar or a vector that is the same length as the channel vector. If you specify a scalar

value, that setting is replicated over the channel vector. If you specify a value of 1, the corresponding channel is reset to the value specified in the initial value vector. If you specify a value of 0, the channel remains at the last value attained while the model was running.

Initial value vector

The initial value vector contains the initial voltage values for the output channels. Enter a scalar or a vector that is the same length as the channel vector. If you specify a scalar value, that value is replicated as the initial value over the channel vector. The channels are set to the initial values between the time the model is downloaded and the time it is started.

Sample time

Enter the base sample time or a multiple of the base sample time (- 1 means sample time is inherited).

PCI slot (-1:autosearch)

If only one board of this type is in the target computer, enter - 1 to locate the board.

If two or more boards of this type are in the target computer, enter the bus number and the PCI slot number of the board associated with this driver block. Use the format **[BusNumber, SlotNumber]**.

To determine the bus number and the PCI slot number, type:

```
tg = slrt;  
getPCIInfo(tg, 'installed')
```

External Websites

- www.ni.com

National Instruments PCI/PXI-6733 Digital Input

PCI/PXI-6733 Digital Input block

Library

Simulink Real-Time Library for National Instruments

Scaling Input to Output

I/O Module Input	Block Output Data Type	Scaling
TTL	Double	TTL low = 0.0 TTL high = 1.0

Block Parameters

Channel vector

Enter numbers between 1 and 8 to select the digital input lines used with this block. This driver allows the selection of individual digital input lines in arbitrary order. The number of elements defines the number of digital lines used.

For example, to use all of the digital inputs with this block, enter

```
[1,2,3,4,5,6,7,8]
```

Each line can be used for input or output. If a line is not listed in this field, a digital output block using the same board can use that line.

Number the lines beginning with 1 even if this board manufacturer starts numbering the lines with 0.

Sample time

Enter the base sample time or a multiple of the base sample time (-1 means sample time is inherited).

PCI slot (-1:autosearch)

If only one board of this type is in the target computer, enter - 1 to locate the board.

If two or more boards of this type are in the target computer, enter the bus number and the PCI slot number of the board associated with this driver block. Use the format **[BusNumber,SlotNumber]**.

To determine the bus number and the PCI slot number, type:

```
tg = slrt;  
getPCIInfo(tg, 'installed')
```

External Websites

- www.ni.com

National Instruments PCI/PXI-6733 Digital Output

PCI/PXI-6733 Digital Output

Library

Simulink Real-Time Library for National Instruments

Scaling Input to Output

I/O Module Output	Block Input Data Type	Scaling
TTL	Double	$< 0.5 = \text{TTL low}$ $\geq 0.5 = \text{TTL high}$

Block Parameters

Channel vector

Enter numbers between 1 and 8 to select the digital output lines used with this block. This driver allows the selection of individual digital output lines in arbitrary order. The number of elements defines the number of digital lines used.

For example, to use all of the digital outputs with this block, enter

```
[1,2,3,4,5,6,7,8]
```

Each line can be used for input or output. If a line is not listed in this field, a digital input block using the same board can use that line.

Number the lines beginning with 1 even if this board manufacturer starts numbering the lines with 0.

Reset vector

The reset vector controls the behavior of the channel at model termination. Enter a scalar or a vector that is the same length as the channel vector. If you specify a scalar value, that setting is replicated over the channel vector. If you specify a value of 1, the corresponding channel is reset to the value specified in the initial value vector.

If you specify a value of 0, the channel remains at the last value attained while the model was running.

Initial value vector

The initial value vector contains the initial values (0 or 1) of the output channels. Enter a scalar or a vector that is the same length as the channel vector. If you enter a scalar, that value is replicated as the initial value over the channel vector. The channels are set to these initial values between the time the model is downloaded and the time it is started.

Sample time

Enter the base sample time or a multiple of the base sample time (- 1 means sample time is inherited).

PCI slot (-1:autosearch)

If only one board of this type is in the target computer, enter - 1 to locate the board.

If two or more boards of this type are in the target computer, enter the bus number and the PCI slot number of the board associated with this driver block. Use the format **[BusNumber, SlotNumber]**.

To determine the bus number and the PCI slot number, type:

```
tg = slrt;  
getPCIInfo(tg, 'installed')
```

External Websites

- www.ni.com

National Instruments PCI/PXI-6733 Pulse Generation

PCI/PXI-6733 Pulse Generation block

Library

Simulink Real-Time Library for National Instruments

Note

The inputs to the block should be a two-element vector. The first element is the number of counts (of the 20 MHz source clock) that the counter should maintain at a low level, and the second element is the number of clock ticks for a high level. For example, to generate a pulse train at 1 kHz with 25% low and 75% high, use the vector

```
[5000 15000]
```

Block Parameters

Counter

From the list, choose **Counter 0**, **Counter 1**, or **Both** to select the counter(s) to be used with this driver block. In each case, one block is required for each physical board.

Sample time

Enter the base sample time or a multiple of the base sample time (- 1 means sample time is inherited).

PCI slot (-1:autosearch)

If only one board of this type is in the target computer, enter - 1 to locate the board.

If two or more boards of this type are in the target computer, enter the bus number and the PCI slot number of the board associated with this driver block. Use the format **[BusNumber, SlotNumber]**.

To determine the bus number and the PCI slot number, type:

```
tg = slrt;  
getPCIInfo(tg, 'installed')
```

External Websites

- www.ni.com

National Instruments PCI/PXI-6733 Pulse Width/Period Measurement

PCI/PXI-6733 Pulse Width/Period Measurement block

Library

Simulink Real-Time Library for National Instruments

Block Parameters

Counter

From the list, select a counter, 0 or 1.

Trigger mode

From the list, choose **Level Triggered** or **Edge Triggered**. See the table below for an example of how **Trigger mode** and **Polarity** interact. In this table, the data in the Output column resulted from a 1 kHz pulse train with a 25% low and a 75% high pulse.

Polarity

From the list, choose **Active low** or **Active high**. See the table below for an example of how **Trigger mode** and **Polarity** interact. In this table, the data in the Output column resulted from a 1 kHz pulse train with a 25% low and a 75% high pulse.

Measurement Objective	Trigger Mode	Polarity	Output
Pulse width (low pulse)	Level triggered	Active low	5000
Pulse width (high pulse)	Level triggered	Active high	15000
Period	Edge triggered	NA	20000

In every case, the output of the block is the number of clock ticks (of the 20 MHz source clock) required for the specified measurement. When measuring pulse width,

the output reflects the number of clock ticks for which the input signal was in the specified (low or high) state. See the table above for an example.

Sample time

Enter the base sample time or a multiple of the base sample time (- 1 means sample time is inherited).

PCI slot (-1:autosearch)

If only one board of this type is in the target computer, enter - 1 to locate the board.

If two or more boards of this type are in the target computer, enter the bus number and the PCI slot number of the board associated with this driver block. Use the format **[BusNumber,SlotNumber]**.

To determine the bus number and the PCI slot number, type:

```
tg = slrt;  
getPCIInfo(tg, 'installed')
```

External Websites

- www.ni.com

National Instruments PCI-DIO-96

Support for National Instruments PCI-DIO-96 board

Board

National Instruments PCI-DIO-96

General Description

The PC-DIO-96 is an I/O board with 96 digital input and output lines.

The Simulink Real-Time block library supports this board with these driver blocks:

- National Instruments PCI-DIO-96 Digital Input
- National Instruments PCI-DIO-96 Digital Output

Board Characteristics

Board name	PC-DIO-96
Manufacturer	National Instruments
Bus type	PCI
Access method	I/O mapped
Multiple block instance support	Yes
Multiple board support	Yes

External Websites

- www.ni.com

National Instruments PCI-DIO-96 Digital Input

PCI-DIO-96 Digital Input block

Library

Simulink Real-Time Library for National Instruments

Note

The PC-DIO-96 has four 8255 chips with 3 ports (A,B,C). Each port has a maximum of 8 digital I/O lines that can be configured as inputs or outputs.

Use a separate driver block for each port. By selecting the digital input driver block, the port is configured as input.

Scaling of Input to Output

I/O Module Input	Block Output Data Type	Scaling
TTL	Double	TTL low = 0.0 TTL high = 1.0

Block Parameters

Channel vector

Enter numbers between 1 and 8 to select the digital input lines used with this port. This driver allows the selection of individual digital input lines in arbitrary order. The number of elements defines the number of digital lines used.

For example, to use all of the digital inputs for one port, enter

```
[1,2,3,4,5,6,7,8]
```

Number the lines beginning with 1 even if this board manufacturer starts numbering the lines with 0.

Port

From the list, choose either **A**, **B**, or **C**. The I/O board has four 8255 chips with 3 ports. The **Port** parameter defines which port of the 8255 chip is used for this driver block. Each port has a maximum of 8 digital lines that can be configured as inputs or outputs depending on which driver block is chosen. In each case, one block is required for each port.

Chip

From the list, choose 1, 2, 3, or 4.

Sample time

Enter the base sample time or a multiple of the base sample time (-1 means sample time is inherited).

PCI slot (-1:autosearch)

If only one board of this type is in the target computer, enter -1 to locate the board.

If two or more boards of this type are in the target computer, enter the bus number and the PCI slot number of the board associated with this driver block. Use the format **[BusNumber,SlotNumber]**.

To determine the bus number and the PCI slot number, type:

```
tg = slrt;  
getPCIInfo(tg, 'installed')
```

External Websites

- www.ni.com

National Instruments PCI-DIO-96 Digital Output

PCI-DIO-96 Digital Output block

Library

Simulink Real-Time Library for National Instruments

Note

The PC-DIO24 has four 8255 chips with 3 ports (A,B,C). Each port has a maximum of 8 digital I/O lines that can be configured as inputs or outputs.

Use a separate driver block for each port. By selecting the digital output driver block, the port is configured as output.

Scaling of Input to Output

I/O Module Output	Block Input Data Type	Scaling
TTL	Double	$< 0.5 = \text{TTL low}$ $\geq 0.5 = \text{TTL high}$

Block Parameters

Channel vector

Enter numbers between 1 and 8 to select the digital output lines used with this port. This driver allows the selection of individual digital output lines in arbitrary order. The number of elements defines the number of digital lines used.

For example, to use all of the digital outputs for one port, enter

```
[1,2,3,4,5,6,7,8]
```

Number the lines beginning with 1 even if this board manufacturer starts numbering the lines with 0.

Port

From the list, choose either **A**, **B**, or **C**. The I/O board has an 8255 chip with 3 ports. The **Port** parameter defines which port of the 8255 chip is used for this driver block. Each port has a maximum of 8 digital lines that can be configured as inputs or outputs depending on which driver block is chosen. In each case, one block is required for each port.

Reset vector

The reset vector controls the behavior of the channel at model termination. Enter a scalar or a vector that is the same length as the channel vector. If you specify a scalar value, that setting is replicated over the channel vector. If you specify a value of 1, the corresponding channel is reset to the value specified in the initial value vector. If you specify a value of 0, the channel remains at the last value attained while the model was running.

Initial value vector

The initial value vector contains the initial values (0 or 1) of the output channels. Enter a scalar or a vector that is the same length as the channel vector. If you enter a scalar, that value is replicated as the initial value over the channel vector. The channels are set to these initial values between the time the model is downloaded and the time it is started.

Chip

From the list, choose 1, 2, 3, or 4.

Sample time

Enter the base sample time or a multiple of the base sample time (-1 means sample time is inherited).

PCI slot (-1:autosearch)

If only one board of this type is in the target computer, enter -1 to locate the board.

If two or more boards of this type are in the target computer, enter the bus number and the PCI slot number of the board associated with this driver block. Use the format **[BusNumber, SlotNumber]**.

To determine the bus number and the PCI slot number, type:

```
tg = slrt;  
getPCIInfo(tg, 'installed')
```

External Websites

- www.ni.com

National Instruments PXI-6040E

Support for National Instruments PXI-6040E board

Board

National Instruments PXI-6040E

General Description

The PXI-6040E is an I/O board with 16 single or 8 differential analog input channels (12-bit) with a maximum sample rate of 500 kHz, 2 analog output channels (12-bit), 8 digital input and output lines, and 2 counter/timers (24-bit) with a maximum source clock rate of 20 MHz.

The Simulink Real-Time block library supports this board with these driver blocks:

- National Instruments PXI-6040E Analog Input (A/D)
- National Instruments PXI-6040E Analog Output (D/A)
- National Instruments PXI-6040E Digital Input
- National Instruments PXI-6040E Digital Output
- National Instruments PXI-6040E Pulse Generation
- National Instruments PXI-6040E Pulse Width/Period Measurement

Board Characteristics

Board name	PXI-6040E
Manufacturer	National Instruments
Bus type	PXI (Compact PCI)
Access method	Memory mapped
Multiple block instance support	A/D: No, D/A: No, Digital I/O: Yes; Pulse Width/Period measurement: Yes; Pulse Train Generation: No

Multiple board support

Yes

External Websites

- www.ni.com

National Instruments PXI-6040E Analog Input (A/D)

PXI-6040E Analog Input block

Library

Simulink Real-Time Library for National Instruments

Scaling Input to Output

I/O Module Input	Block Output Data Type	Scaling
Volts	Double	1

Block Parameters

Channel vector

Enter numbers between 1 and 16. This driver allows you to enter channel numbers in arbitrary order.

For example, to use the first, second, and fifth channels, enter

[1,2,5]

Number the channels beginning with 1 even if this board manufacturer starts numbering the channels with 0.

Range vector

Enter a range code for each of the channels in the channel vector. The range vector must be the same length as the channel vector. This driver allows each channel to be different.

The following table is a list of the ranges for this driver and the corresponding range codes.

Input Range (V)	Range Code
-10 to +10	-10

Input Range (V)	Range Code
-5 to +5	-5
-2 to +2	-2
-1 to +1	-1
-0.5 to +0.5	-0.5
-0.2 to +0.2	-0.2
-0.1 to +0.1	-0.1
-0.05 to +0.05	-0.05
0 to +10	10
0 to +5	5
0 to +2	2
0 to +1	1
0 to +0.5	0.5
0 to +0.2	0.2
0 to +0.1	0.1

For example, if the first channel is -10 to +10 volts and the second and fifth channels are 0 to +1 volts, enter

[-10, 1, 1]

Input coupling vector

Enter a coupling code for each of the channels in the channel vector. The coupling vector must be the same length as the channel vector. This driver allows a different coupling for each channel.

The following table is a list of the couplings for this driver and the corresponding coupling codes.

Coupling	Coupling Code	Description
RSE	0	Analog input line connected to the positive input of the PGIA. Analog input ground (AIGND) internally connected to the negative input of the PGIA. See the board manual.

Coupling	Coupling Code	Description
NRSE	1	Analog input line connected to the positive input of the PGIA. Analog input sense (AISENSE) connected to the negative input of the PGIA. See the board manual.
DIFF	2	First analog input line connected to the positive input of the PGIA. Second analog input line connected to the negative input of the PGIA. See the board manual.

For example, if the first and second channels are single input and the fifth channel is a differential input, enter

```
[0,0,2]
```

The driver selects a second differential input 8 channels higher than the first channel. In the example above, the driver would select the thirteenth channel as a differential input with the fifth channel.

If the board is set up for differential mode, you can read the data from either of the channels in the differential pair. For example, if you have a differential pair of 1 and 9, you can read the data from channel 1 or channel 9. However, you might want to read the lower channel number of the pair because it remains unchanged when you switch the input mode between single-ended and differential.

Sample time

Enter the base sample time or a multiple of the base sample time (- 1 means sample time is inherited).

PCI slot (-1:autosearch)

If only one board of this type is in the target computer, enter - 1 to locate the board.

If two or more boards of this type are in the target computer, enter the bus number and the PCI slot number of the board associated with this driver block. Use the format **[BusNumber,SlotNumber]**.

To determine the bus number and the PCI slot number, type:

```
tg = slrt;
getPCIInfo(tg, 'installed')
```

External Websites

- www.ni.com

National Instruments PXI-6040E Analog Output (D/A)

PXI-6040E Analog Output block

Library

Simulink Real-Time Library for National Instruments

Scaling of Input to Output

I/O Module Output	Block Input Data Type	Scaling
Volts	Double	1

Block Parameters

Channel vector

Enter 1 or 2. This driver allows the selection of individual D/A channels in arbitrary order. The number of elements defines the number of D/A channels used. For example, to use both of the analog output channels, enter

[1,2]

Number the channels beginning with 1 even if this board manufacturer starts numbering the channels with 0.

Range vector

Enter a range code for each of the channels in the channel vector. The range vector must be the same length as the channel vector. This board allows the range of each channel to be different.

The following table is a list of the ranges for this driver and the corresponding range codes.

Input Range (V)	Range Code
-10 to +10	-10

Input Range (V)	Range Code
0 to +10	10

For example, if the first channel is -10 to +10 volts and the second channel is 0 to +10 volts, enter

```
[ -10, 10]
```

Reset vector

The reset vector controls the behavior of the channel at model termination. Enter a scalar or a vector that is the same length as the channel vector. If you specify a scalar value, that setting is replicated over the channel vector. If you specify a value of 1, the corresponding channel is reset to the value specified in the initial value vector. If you specify a value of 0, the channel remains at the last value attained while the model was running.

Initial value vector

The initial value vector contains the initial voltage values for the output channels. Enter a scalar or a vector that is the same length as the channel vector. If you specify a scalar value, that value is replicated as the initial value over the channel vector. The channels are set to the initial values between the time the model is downloaded and the time it is started.

Sample time

Enter the base sample time or a multiple of the base sample time (-1 means sample time is inherited).

PCI slot (-1:autosearch)

If only one board of this type is in the target computer, enter -1 to locate the board.

If two or more boards of this type are in the target computer, enter the bus number and the PCI slot number of the board associated with this driver block. Use the format **[BusNumber, SlotNumber]**.

To determine the bus number and the PCI slot number, type:

```
tg = slrt;
getPCIInfo(tg, 'installed')
```

External Websites

- www.ni.com

National Instruments PXI-6040E Digital Input

PXI-6040E Digital Input block

Library

Simulink Real-Time Library for National Instruments

Scaling Input to Output

I/O Module Input	Block Output Data Type	Scaling
TTL	Double	TTL low = 0.0 TTL high = 1.0

Block Parameters

Channel vector

Enter numbers between 1 and 8 to select the digital input lines used with this port. This driver allows the selection of individual digital input lines in arbitrary order. The number of elements defines the number of digital lines used.

For example, to use all of the digital inputs for one port, enter

```
[1,2,3,4,5,6,7,8]
```

Number the lines beginning with 1 even if this board manufacturer starts numbering the lines with 0.

Sample time

Enter the base sample time or a multiple of the base sample time (-1 means sample time is inherited).

PCI slot (-1:autosearch)

If only one board of this type is in the target computer, enter -1 to locate the board.

If two or more boards of this type are in the target computer, enter the bus number and the PCI slot number of the board associated with this driver block. Use the format **[BusNumber,SlotNumber]**.

To determine the bus number and the PCI slot number, type:

```
tg = slrt;  
getPCIInfo(tg, 'installed')
```

External Websites

- www.ni.com

National Instruments PXI-6040E Digital Output

PXI-6040E Digital Output block

Library

Simulink Real-Time Library for National Instruments

Scaling Input to Output

I/O Module Output	Block Input Data Type	Scaling
TTL	Double	TTL low = 0.0 TTL high = 1.0

Block Parameters

Channel vector

Enter numbers between 1 and 8 to select the digital output lines used with this port. This driver allows the selection of individual digital output lines in arbitrary order. The number of elements defines the number of digital lines used.

For example, to use all of the digital outputs for one port, enter

[1,2,3,4,5,6,7,8]

Number the lines beginning with 1 even if this board manufacturer starts numbering the lines with 0.

Reset vector

The reset vector controls the behavior of the channel at model termination. Enter a scalar or a vector that is the same length as the channel vector. If you specify a scalar value, that setting is replicated over the channel vector. If you specify a value of 1, the corresponding channel is reset to the value specified in the initial value vector. If you specify a value of 0, the channel remains at the last value attained while the model was running.

Initial value vector

The initial value vector contains the initial values (0 or 1) of the output channels. Enter a scalar or a vector that is the same length as the channel vector. If you enter a scalar, that value is replicated as the initial value over the channel vector. The channels are set to these initial values between the time the model is downloaded and the time it is started.

Sample time

Enter the base sample time or a multiple of the base sample time (- 1 means sample time is inherited).

PCI slot (-1:autosearch)

If only one board of this type is in the target computer, enter - 1 to locate the board.

If two or more boards of this type are in the target computer, enter the bus number and the PCI slot number of the board associated with this driver block. Use the format **[BusNumber,SlotNumber]**.

To determine the bus number and the PCI slot number, type:

```
tg = slrt;  
getPCIInfo(tg, 'installed')
```

External Websites

- www.ni.com

National Instruments PXI-6040E Pulse Generation

PXI-6040E Pulse Generation block

Library

Simulink Real-Time Library for National Instruments

Note

The inputs to the block should be a two-element vector. The first element is the number of counts (of the 20 MHz source clock) that the counter should maintain at a low level, and the second element is the number of clock ticks for a high level. For example, to generate a pulse train at 1 kHz with 25% low and 75% high, use the vector

```
[5000 15000]
```

Block Parameters

Counter

From the list, choose **Counter 0**, **Counter 1**, or **Both** to select the counter(s) to be used with this driver block. In each case, one block is required for each physical board.

Sample time

Enter the base sample time or a multiple of the base sample time (-1 means sample time is inherited).

PCI slot (-1:autosearch)

If only one board of this type is in the target computer, enter -1 to locate the board.

If two or more boards of this type are in the target computer, enter the bus number and the PCI slot number of the board associated with this driver block. Use the format **[BusNumber, SlotNumber]**.

To determine the bus number and the PCI slot number, type:

```
tg = slrt;  
getPCIInfo(tg, 'installed')
```

External Websites

- www.ni.com

National Instruments PXI-6040E Pulse Width/Period Measurement

PXI-6040E Pulse Width/Period Measurement block

Library

Simulink Real-Time Library for National Instruments

Note

Connect the signal you want to measure to the GATE input of the chosen counter. The signal must have fast rise and fall times; otherwise, the counter might experience false triggering. Use signal voltage levels between 0 and 5 volts (TTL levels).

Block Parameters

Counter

From the list, select a counter, 0 or 1.

Trigger mode

From the list, choose **Level Triggered** or **Edge Triggered**. See the table below for an example of how **Trigger mode** and **Polarity** interact. In this table, the data in the Output column resulted from a 1 kHz pulse train with a 25% low and a 75% high pulse.

Polarity

From the list, choose **Active low** or **Active high**. See the table below for an example of how **Trigger mode** and **Polarity** interact. In this table, the data in the Output column resulted from a 1 kHz pulse train with a 25% low and a 75% high pulse.

Measurement Objective	Trigger Mode	Polarity	Output
Pulse width (low pulse)	Level triggered	Active low	5000

Measurement Objective	Trigger Mode	Polarity	Output
Pulse width (high pulse)	Level triggered	Active high	15000
Period	Edge triggered	NA	20000

In every case, the output of the block is the number of clock ticks (of the 20 MHz source clock) required for the specified measurement. When measuring pulse width, the output reflects the number of clock ticks for which the input signal was in the specified (low or high) state. See the table above for an example.

Sample time

Enter the base sample time or a multiple of the base sample time (- 1 means sample time is inherited).

PCI slot (-1:autosearch)

If only one board of this type is in the target computer, enter - 1 to locate the board.

If two or more boards of this type are in the target computer, enter the bus number and the PCI slot number of the board associated with this driver block. Use the format **[BusNumber,SlotNumber]**.

To determine the bus number and the PCI slot number, type:

```
tg = slrt;
getPCIInfo(tg, 'installed')
```

External Websites

- www.ni.com

National Instruments PXI-6070E

Support for National Instruments PXI-6070E board

Board

National Instruments PXI-6070E

General Description

The PXI-6070E is an I/O board with 16 single or 8 differential analog input channels (12-bit) with a maximum sample rate of 1.25 MHz, 2 analog output channels (12-bit), 8 digital input and output lines, and 2 counter/timers (24-bit) with a maximum source clock rate of 20 MHz.

The Simulink Real-Time block library supports this board with these driver blocks:

- National Instruments PXI-6070E Analog Input (A/D)
- National Instruments PXI-6070E Analog Output (D/A)
- National Instruments PXI-6070E Digital Input
- National Instruments PXI-6070E Digital Output
- National Instruments PXI-6070E Pulse Generation
- National Instruments PXI-6070E Pulse Width/Period Measurement

Board Characteristics

Board name	PXI-6070E
Manufacturer	National Instruments
Bus type	PXI (Compact PCI)
Multiple block instance support	A/D: No, D/A: No, Digital I/O: Yes; Pulse Width/Period measurement: Yes; Pulse Train Generation: No
Multiple board support	Yes

External Websites

- www.ni.com

National Instruments PXI-6070E Analog Input (A/D)

PXI-6070E Analog Input block

Library

Simulink Real-Time Library for National Instruments

Scaling Input to Output

I/O Module Input	Block Output Data Type	Scaling
Volts	Double	1

Block Parameters

Channel vector

Enter numbers between 1 and 16. This driver allows you to enter channel numbers in arbitrary order.

For example, to use the first, second, and fifth channels, enter

[1,2,5]

Number the channels beginning with 1 even if this board manufacturer starts numbering the channels with 0.

Range vector

Enter a range code for each of the channels in the channel vector. The range vector must be the same length as the channel vector. This driver allows each channel to be different.

The following table is a list of the ranges for this driver and the corresponding range codes.

Input Range (V)	Range Code
-10 to +10	-10

Input Range (V)	Range Code
-5 to +5	-5
-2 to +2	-2
-1 to +1	-1
-0.5 to +0.5	-0.5
-0.2 to +0.2	-0.2
-0.1 to +0.1	-0.1
-0.05 to +0.05	-0.05
0 to +10	10
0 to +5	5
0 to +2	2
0 to +1	1
0 to +0.5	0.5
0 to +0.2	0.2
0 to +0.1	0.1

For example, if the first channel is -10 to +10 volts and the second and fifth channels are 0 to +1 volts, enter

[-10, 1, 1]

Input coupling vector

Enter a coupling code for each of the channels in the channel vector. The coupling vector must be the same length as the channel vector. This driver allows a different coupling for each channel.

The following table is a list of the couplings for this driver and the corresponding coupling codes.

Coupling	Coupling Code	Description
RSE	0	Analog input line connected to the positive input of the PGIA. Analog input ground (AIGND) internally connected to the negative input of the PGIA. See the board manual.

Coupling	Coupling Code	Description
NRSE	1	Analog input line connected to the positive input of the PGIA. Analog input sense (AISENSE) connected to the negative input of the PGIA. See the board manual.
DIFF	2	First analog input line connected to the positive input of the PGIA. Second analog input line connected to the negative input of the PGIA. See the board manual.

For example, if the first and second channels are single input and the fifth channel is a differential input, enter

```
[0,0,2]
```

The driver selects a second differential input 8 channels higher than the first channel. In the example above, the driver would select the thirteenth channel as a differential input with the fifth channel.

If the board is set up for differential mode, you can read the data from either of the channels in the differential pair. For example, if you have a differential pair of 1 and 9, you can read the data from channel 1 or channel 9. However, you might want to read the lower channel number of the pair because it remains unchanged when you switch the input mode between single-ended and differential.

Sample time

Enter the base sample time or a multiple of the base sample time (- 1 means sample time is inherited).

PCI slot (-1:autosearch)

If only one board of this type is in the target computer, enter - 1 to locate the board.

If two or more boards of this type are in the target computer, enter the bus number and the PCI slot number of the board associated with this driver block. Use the format **[BusNumber,SlotNumber]**.

To determine the bus number and the PCI slot number, type:

```
tg = slrt;
getPCIInfo(tg, 'installed')
```

External Websites

- www.ni.com

National Instruments PXI-6070E Analog Output (D/A)

PXI-6070E Analog Output block

Library

Simulink Real-Time Library for National Instruments

Scaling Input to Output

I/O Module Output	Block Input Data Type	Scaling
Volts	Double	1

Block Parameters

Channel vector

Enter 1 or 2. This driver allows the selection of individual D/A channels in arbitrary order. The number of elements defines the number of D/A channels used. For example, to use both of the analog output channels, enter

[1,2]

Number the channels beginning with 1 even if this board manufacturer starts numbering the channels with 0.

Range vector

Enter a range code for each of the channels in the channel vector. The range vector must be the same length as the channel vector. This board allows the range of each channel to be different.

The following table is a list of the ranges for this driver and the corresponding range codes.

Input Range (V)	Range Code
-10 to +10	-10

Input Range (V)	Range Code
0 to +10	10

For example, if the first channel is -10 to +10 volts and the second channel is 0 to +10 volts, enter

```
[ -10, 10]
```

Reset vector

The reset vector controls the behavior of the channel at model termination. Enter a scalar or a vector that is the same length as the channel vector. If you specify a scalar value, that setting is replicated over the channel vector. If you specify a value of 1, the corresponding channel is reset to the value specified in the initial value vector. If you specify a value of 0, the channel remains at the last value attained while the model was running.

Initial value vector

The initial value vector contains the initial voltage values for the output channels. Enter a scalar or a vector that is the same length as the channel vector. If you specify a scalar value, that value is replicated as the initial value over the channel vector. The channels are set to the initial values between the time the model is downloaded and the time it is started.

Sample time

Enter the base sample time or a multiple of the base sample time (-1 means sample time is inherited).

PCI slot (-1:autosearch)

If only one board of this type is in the target computer, enter -1 to locate the board.

If two or more boards of this type are in the target computer, enter the bus number and the PCI slot number of the board associated with this driver block. Use the format **[BusNumber, SlotNumber]**.

To determine the bus number and the PCI slot number, type:

```
tg = slrt;
getPCIInfo(tg, 'installed')
```

External Websites

- www.ni.com

National Instruments PXI-6070E Digital Input

PXI-6070E Digital Input block

Library

Simulink Real-Time Library for National Instruments

Scaling Input to Output

I/O Module Input	Block Output Data Type	Scaling
TTL	Double	TTL low = 0.0 TTL high = 1.0

Block Parameters

Channel vector

Enter numbers between 1 and 8 to select the digital input lines used with this port. This driver allows the selection of individual digital input lines in arbitrary order. The number of elements defines the number of digital lines used.

For example, to use all of the digital inputs for one port, enter

```
[1,2,3,4,5,6,7,8]
```

Number the lines beginning with 1 even if this board manufacturer starts numbering the lines with 0.

Sample time

Enter the base sample time or a multiple of the base sample time (-1 means sample time is inherited).

PCI slot (-1:autosearch)

If only one board of this type is in the target computer, enter -1 to locate the board.

If two or more boards of this type are in the target computer, enter the bus number and the PCI slot number of the board associated with this driver block. Use the format **[BusNumber,SlotNumber]**.

To determine the bus number and the PCI slot number, type:

```
tg = slrt;  
getPCIInfo(tg, 'installed')
```

External Websites

- www.ni.com

National Instruments PXI-6070E Digital Output

PXI-6070E Digital Output block

Library

Simulink Real-Time Library for National Instruments

Scaling Input to Output

I/O Module Output	Block Input Data Type	Scaling
TTL	Double	$< 0.5 = \text{TTL low}$ $\geq 0.5 = \text{TTL high}$

Block Parameters

Channel vector

Enter numbers between 1 and 8 to select the digital output lines used with this port. This driver allows the selection of individual digital output lines in arbitrary order. The number of elements defines the number of digital lines used.

For example, to use all of the digital outputs for one port, enter

[1,2,3,4,5,6,7,8]

Number the lines beginning with 1 even if this board manufacturer starts numbering the lines with 0.

Reset vector

The reset vector controls the behavior of the channel at model termination. Enter a scalar or a vector that is the same length as the channel vector. If you specify a scalar value, that setting is replicated over the channel vector. If you specify a value of 1, the corresponding channel is reset to the value specified in the initial value vector. If you specify a value of 0, the channel remains at the last value attained while the model was running.

Initial value vector

The initial value vector contains the initial values (0 or 1) of the output channels. Enter a scalar or a vector that is the same length as the channel vector. If you enter a scalar, that value is replicated as the initial value over the channel vector. The channels are set to these initial values between the time the model is downloaded and the time it is started.

Sample time

Enter the base sample time or a multiple of the base sample time (- 1 means sample time is inherited).

PCI slot (-1:autosearch)

If only one board of this type is in the target computer, enter - 1 to locate the board.

If two or more boards of this type are in the target computer, enter the bus number and the PCI slot number of the board associated with this driver block. Use the format [**BusNumber**,**SlotNumber**].

To determine the bus number and the PCI slot number, type:

```
tg = slrt;  
getPCIInfo(tg, 'installed')
```

External Websites

- www.ni.com

National Instruments PXI-6070E Pulse Generation

PXI-6070E Pulse Generation block

Library

Simulink Real-Time Library for National Instruments

Note

The inputs to the block should be a two-element vector. The first element is the number of counts (of the 20 MHz source clock) that the counter should maintain at a low level, and the second element is the number of clock ticks for a high level. For example, to generate a pulse train at 1 kHz with 25% low and 75% high, use the vector

```
[5000 15000]
```

Block Parameters

Counter

From the list, choose **Counter 0**, **Counter 1**, or **Both** to select the counter(s) to be used with this driver block. In each case, one block is required for each physical board.

Sample time

Enter the base sample time or a multiple of the base sample time (-1 means sample time is inherited).

PCI slot (-1:autosearch)

If only one board of this type is in the target computer, enter -1 to locate the board.

If two or more boards of this type are in the target computer, enter the bus number and the PCI slot number of the board associated with this driver block. Use the format **[BusNumber, SlotNumber]**.

To determine the bus number and the PCI slot number, type:

```
tg = slrt;  
getPCIInfo(tg, 'installed')
```

External Websites

- www.ni.com

National Instruments PXI-6070E Pulse Width/Period Measurement

PXI-6070E Pulse Width/Period Measurement block

Library

Simulink Real-Time Library for National Instruments

Note

Connect the signal you want to measure to the GATE input of the chosen counter. The signal must have fast rise and fall times; otherwise, the counter might experience false triggering. Use signal voltage levels between 0 and 5 volts (TTL levels).

Block Parameters

Counter

From the list, select a counter, 0 or 1.

Trigger mode

From the list, choose **Level Triggered** or **Edge Triggered**. See the table below for an example of how **Trigger mode** and **Polarity** interact. In this table, the data in the Output column resulted from a 1 kHz pulse train with a 25% low and a 75% high pulse.

Polarity

From the list, choose **Active low** or **Active high**. See the table below for an example of how **Trigger mode** and **Polarity** interact. In this table, the data in the Output column resulted from a 1 kHz pulse train with a 25% low and a 75% high pulse.

Measurement Objective	Trigger Mode	Polarity	Output
Pulse width (low pulse)	Level triggered	Active low	5000

Measurement Objective	Trigger Mode	Polarity	Output
Pulse width (high pulse)	Level triggered	Active high	15000
Period	Edge triggered	NA	20000

In every case, the output of the block is the number of clock ticks (of the 20 MHz source clock) required for the specified measurement. When measuring pulse width, the output reflects the number of clock ticks for which the input signal was in the specified (low or high) state. See the table above for an example.

Sample time

Enter the base sample time or a multiple of the base sample time (- 1 means sample time is inherited).

PCI slot (-1:autosearch)

If only one board of this type is in the target computer, enter - 1 to locate the board.

If two or more boards of this type are in the target computer, enter the bus number and the PCI slot number of the board associated with this driver block. Use the format **[BusNumber,SlotNumber]**.

To determine the bus number and the PCI slot number, type:

```
tg = slrt;
getPCIInfo(tg, 'installed')
```

External Websites

- www.ni.com

National Instruments PXI-6071E

Support for National Instruments PXI-6071E board

Board

National Instruments PXI-6071E

General Description

The PXI-6071E is an I/O board with 64 single or 32 differential analog input (A/D) channels (12-bit) with a maximum sample rate of 1.25 MHz, 2 analog output (D/A) channels (12-bit), 8 digital input and output lines, and 2 counter/timers (24-bit) with a maximum source clock rate of 20 MHz.

The Simulink Real-Time block library supports this board with these driver blocks:

- National Instruments PXI-6071E Analog Input (A/D)
- National Instruments PXI-6071E Analog Output (D/A)
- National Instruments PXI-6071E Digital Input
- National Instruments PXI-6071E Digital Output
- National Instruments PXI-6071E Pulse Generation
- National Instruments PXI-6071E Pulse Width/Period Measurement

Board Characteristics

Board Name	PXI-6071E
Manufacturer	National Instruments
Bus type	PXI
Access method	Memory mapped
Multiple block instance support	A/D: No, D/A: No, Digital I/O: Yes; Pulse Width/Period measurement: Yes; Pulse Train Generation: No

Multiple board support

Yes

External Websites

- www.ni.com

National Instruments PXI-6071E Analog Input (A/D)

PXI-6071E Analog Input block

Library

Simulink Real-Time Library for National Instruments

Scaling Input to Output

I/O Module Input	Block Output Data Type	Scaling
Volts	Double	1

Block Parameters

Channel vector

Enter numbers between 1 and 64. This driver allows you to enter channel numbers in arbitrary order.

For example, to use the first, second, and fifth channels, enter

[1,2,5]

Number the channels beginning with 1 even if this board manufacturer starts numbering the channels with 0.

Range vector

Enter a range code for each of the channels in the channel vector. The range vector must be the same length as the channel vector. This driver allows each channel to be different.

The following table is a list of the ranges for this driver and the corresponding range codes.

Input Range (V)	Range Code
-10 to +10	-10

Input Range (V)	Range Code
-5 to +5	-5
-2 to +2	-2
-1 to +1	-1
-0.5 to +0.5	-0.5
-0.2 to +0.2	-0.2
-0.1 to +0.1	-0.1
-0.05 to +0.05	-0.05
0 to +10	10
0 to +5	5
0 to +2	2
0 to +1	1
0 to +0.5	0.5
0 to +0.2	0.2
0 to +0.1	0.1

For example, if the first channel is -10 to +10 volts and the second and fifth channels are 0 to +1 volts, enter

[-10, 1, 1]

Input coupling vector

Enter a coupling code for each of the channels in the channel vector. The coupling vector must be the same length as the channel vector. This driver allows a different coupling for each channel.

The following table is a list of the couplings for this driver and the corresponding coupling codes.

Coupling	Coupling Code	Description
RSE	0	Analog input line connected to the positive input of the PGIA. Analog input ground (AIGND) internally connected to the negative input of the PGIA. See the board manual.

Coupling	Coupling Code	Description
NRSE	1	Analog input line connected to the positive input of the PGIA. Analog input sense (AISENSE) connected to the negative input of the PGIA. See the board manual.
DIFF	2	First analog input line connected to the positive input of the PGIA. Second analog input line connected to the negative input of the PGIA. See the board manual.

For example, if the first and second channels are single input and the fifth channel is a differential input, enter

```
[0,0,2]
```

The driver selects a second differential input 8 channels higher than the first channel. In the example above, the driver would select the thirteenth channel as a differential input with the fifth channel.

If the board is set up for differential mode, you can read the data from either of the channels in the differential pair. For example, if you have a differential pair of 1 and 9, you can read the data from channel 1 or channel 9. However, you might want to read the lower channel number of the pair because it remains unchanged when you switch the input mode between single-ended and differential.

Sample time

Enter the base sample time or a multiple of the base sample time (- 1 means sample time is inherited).

PCI slot (-1:autosearch)

If only one board of this type is in the target computer, enter - 1 to locate the board.

If two or more boards of this type are in the target computer, enter the bus number and the PCI slot number of the board associated with this driver block. Use the format **[BusNumber,SlotNumber]**.

To determine the bus number and the PCI slot number, type:

```
tg = slrt;
getPCIInfo(tg, 'installed')
```

External Websites

- www.ni.com

National Instruments PXI-6071E Analog Output (D/A)

PXI-6071E Analog Output block

Library

Simulink Real-Time Library for National Instruments

Scaling Input to Output

I/O Module Output	Block Input Data Type	Scaling
Volts	Double	1

Block Parameters

Channel vector

Enter 1 or 2. This driver allows the selection of individual D/A channels in arbitrary order. The number of elements defines the number of D/A channels used. For example, to use both of the analog output channels, enter

[1,2]

Number the channels beginning with 1 even if this board manufacturer starts numbering the channels with 0.

Range vector

Enter a range code for each of the channels in the channel vector. The range vector must be the same length as the channel vector. This board allows the range of each channel to be different.

The following table is a list of the ranges for this driver and the corresponding range codes.

Input Range (V)	Range Code
-10 to +10	-10

Input Range (V)	Range Code
0 to +10	10

For example, if the first channel is -10 to +10 volts and the second channel is 0 to +10 volts, enter

```
[-10, 10]
```

Reset vector

The reset vector controls the behavior of the channel at model termination. Enter a scalar or a vector that is the same length as the channel vector. If you specify a scalar value, that setting is replicated over the channel vector. If you specify a value of 1, the corresponding channel is reset to the value specified in the initial value vector. If you specify a value of 0, the channel remains at the last value attained while the model was running.

Initial value vector

The initial value vector contains the initial voltage values for the output channels. Enter a scalar or a vector that is the same length as the channel vector. If you specify a scalar value, that value is replicated as the initial value over the channel vector. The channels are set to the initial values between the time the model is downloaded and the time it is started.

Sample time

Enter the base sample time or a multiple of the base sample time (-1 means sample time is inherited).

PCI slot (-1:autosearch)

If only one board of this type is in the target computer, enter -1 to locate the board.

If two or more boards of this type are in the target computer, enter the bus number and the PCI slot number of the board associated with this driver block. Use the format **[BusNumber, SlotNumber]**.

To determine the bus number and the PCI slot number, type:

```
tg = slrt;
getPCIInfo(tg, 'installed')
```

External Websites

- www.ni.com

National Instruments PXI-6071E Digital Input

PXI-6071E Digital Input block

Library

Simulink Real-Time Library for National Instruments

Scaling Input to Output

I/O Module Input	Block Output Data Type	Scaling
TTL	Double	TTL TTL high = 1.0

Block Parameters

Channel vector

Enter numbers between 1 and 8 to select the digital input lines used with this port. This driver allows the selection of individual digital input lines in arbitrary order. The number of elements defines the number of digital lines used.

For example, to use all of the digital inputs for one port, enter

```
[1,2,3,4,5,6,7,8]
```

Number the lines beginning with 1 even if this board manufacturer starts numbering the lines with 0.

Sample time

Enter the base sample time or a multiple of the base sample time (-1 means sample time is inherited).

PCI slot (-1:autosearch)

If only one board of this type is in the target computer, enter -1 to locate the board.

If two or more boards of this type are in the target computer, enter the bus number and the PCI slot number of the board associated with this driver block. Use the format **[BusNumber,SlotNumber]**.

To determine the bus number and the PCI slot number, type:

```
tg = slrt;  
getPCIInfo(tg, 'installed')
```

External Websites

- www.ni.com

National Instruments PXI-6071E Digital Output

PXI-6071E Digital Output block

Library

Simulink Real-Time Library for National Instruments

Scaling Input to Output

I/O Module Output	Block Input Data Type	Scaling
TTL	Double	$< 0.5 = \text{TTL low}$ $\geq 0.5 = \text{TTL high}$

Block Parameters

Channel vector

Enter numbers between 1 and 8 to select the digital output lines used with this port. This driver allows the selection of individual digital output lines in arbitrary order. The number of elements defines the number of digital lines used.

For example, to use all of the digital outputs for one port, enter

[1,2,3,4,5,6,7,8]

Number the lines beginning with 1 even if this board manufacturer starts numbering the lines with 0.

Reset vector

The reset vector controls the behavior of the channel at model termination. Enter a scalar or a vector that is the same length as the channel vector. If you specify a scalar value, that setting is replicated over the channel vector. If you specify a value of 1, the corresponding channel is reset to the value specified in the initial value vector. If you specify a value of 0, the channel remains at the last value attained while the model was running.

Initial value vector

The initial value vector contains the initial values (0 or 1) of the output channels. Enter a scalar or a vector that is the same length as the channel vector. If you enter a scalar, that value is replicated as the initial value over the channel vector. The channels are set to these initial values between the time the model is downloaded and the time it is started.

Sample time

Enter the base sample time or a multiple of the base sample time (- 1 means sample time is inherited).

PCI slot (-1:autosearch)

If only one board of this type is in the target computer, enter - 1 to locate the board.

If two or more boards of this type are in the target computer, enter the bus number and the PCI slot number of the board associated with this driver block. Use the format **[BusNumber,SlotNumber]**.

To determine the bus number and the PCI slot number, type:

```
tg = slrt;  
getPCIInfo(tg, 'installed')
```

External Websites

- www.ni.com

National Instruments PXI-6071E Pulse Generation

PXI-6071E Pulse Generation block

Library

Simulink Real-Time Library for National Instruments

Note

The inputs to the block should be a two-element vector. The first element is the number of counts (of the 20 MHz source clock) that the counter should maintain at a low level, and the second element is the number of clock ticks for a high level. For example, to generate a pulse train at 1 kHz with 25% low and 75% high, use the vector

```
[5000 15000]
```

Block Parameters

Counter

From the list, choose **Counter 0**, **Counter 1**, or **Both** to select the counter(s) to be used with this driver block. In each case, one block is required for each physical board.

Sample time

Enter the base sample time or a multiple of the base sample time (-1 means sample time is inherited).

PCI slot (-1:autosearch)

If only one board of this type is in the target computer, enter -1 to locate the board.

If two or more boards of this type are in the target computer, enter the bus number and the PCI slot number of the board associated with this driver block. Use the format **[BusNumber, SlotNumber]**.

To determine the bus number and the PCI slot number, type:

```
tg = slrt;  
getPCIInfo(tg, 'installed')
```

External Websites

- www.ni.com

National Instruments PXI-6071E Pulse Width/Period Measurement

PXI-6071E Pulse Width/Period Measurement block

Library

Simulink Real-Time Library for National Instruments

Note

Connect the signal you want to measure to the GATE input of the chosen counter. The signal must have fast rise and fall times; otherwise, the counter might experience false triggering. Use signal voltage levels between 0 and 5 volts (TTL levels).

Block Parameters

Counter

From the list, select a counter, 0 or 1.

Trigger mode

From the list, choose **Level Triggered** or **Edge Triggered**. See the table below for an example of how **Trigger mode** and **Polarity** interact. In this table, the data in the Output column resulted from a 1 kHz pulse train with a 25% low and a 75% high pulse.

Polarity

From the list, choose **Active low** or **Active high**. See the table below for an example of how **Trigger mode** and **Polarity** interact. In this table, the data in the Output column is the result of a 1 kHz pulse train with a 25% low and a 75% high pulse.

Measurement Objective	Trigger Mode	Polarity	Output
Pulse width (low pulse)	Level triggered	Active low	5000

Measurement Objective	Trigger Mode	Polarity	Output
Pulse width (high pulse)	Level triggered	Active high	15000
Period	Edge triggered	NA	20000

In every case, the output of the block is the number of clock ticks (of the 20 MHz source clock) required for the specified measurement. When measuring pulse width, the output reflects the number of clock ticks for which the input signal was in the specified (low or high) state. See the table above for an example.

Sample time

Enter the base sample time or a multiple of the base sample time (- 1 means sample time is inherited).

PCI slot (-1:autosearch)

If only one board of this type is in the target computer, enter - 1 to locate the board.

If two or more boards of this type are in the target computer, enter the bus number and the PCI slot number of the board associated with this driver block. Use the format **[BusNumber,SlotNumber]**.

To determine the bus number and the PCI slot number, type:

```
tg = slrt;
getPCIInfo(tg, 'installed')
```

External Websites

- www.ni.com

National Instruments PXI-6508

Support for National Instruments PXI-6508 board

Board

National Instruments PXI-6508

General Description

The PXI-6508 is an I/O board with 96 digital input and output lines.

The Simulink Real-Time block library supports this board with these driver blocks:

- National Instruments PXI-6508 Digital Input
- National Instruments PXI-6508 Digital Output

Board Characteristics

Board name	PXI-6508
Manufacturer	National Instruments
Bus type	PXI (Compact PCI)
Access method	I/O mapped
Multiple block instance support	Yes
Multiple board support	Yes

External Websites

- www.ni.com

National Instruments PXI-6508 Digital Input

PXI-6508 Digital Input block

Library

Simulink Real-Time Library for National Instruments

Note

The PXI-6508 has four 8255 chips with 3 ports (A,B,C). Each port has a maximum of 8 digital I/O lines that can be configured as inputs or outputs.

Use a separate driver block for each port. By selecting the digital input driver block, the port is configured as input.

Scaling of Input to Output

I/O Module Input	Block Output Data Type	Scaling
TTL	Double	TTL low = 0.0 TTL high = 1.0

Block Parameters

Channel vector

Enter numbers between 1 and 8 to select the digital input lines used with this port. This driver allows the selection of individual digital input lines in arbitrary order. The number of elements defines the number of digital lines used.

For example, to use all of the digital inputs for one port, enter

```
[1,2,3,4,5,6,7,8]
```

Number the lines beginning with 1 even if this board manufacturer starts numbering the lines with 0.

Port

From the list, choose either A, B, or C. The I/O board has an 8255 chip with 3 ports. The **Port** parameter defines which port of the 8255 chip is used for this driver block. Each port has a maximum of 8 digital lines that can be configured as inputs or outputs depending on which driver block is chosen. In each case, one block is required for each port.

Chip

From the list, choose 1, 2, 3, or 4.

Sample time

Enter the base sample time or a multiple of the base sample time (-1 means sample time is inherited).

PCI slot (-1:autosearch)

If only one board of this type is in the target computer, enter -1 to locate the board.

If two or more boards of this type are in the target computer, enter the bus number and the PCI slot number of the board associated with this driver block. Use the format **[BusNumber,SlotNumber]**.

To determine the bus number and the PCI slot number, type:

```
tg = slrt;  
getPCIInfo(tg, 'installed')
```

External Websites

- www.ni.com

National Instruments PXI-6508 Digital Output

PXI-6508 Digital Output block

Library

Simulink Real-Time Library for National Instruments

Note

The PXI-6508 has four 8255 chips with 3 ports (A,B,C). Each port has a maximum of 8 digital I/O lines that can be configured as inputs or outputs.

Use a separate driver block for each port. By selecting the digital output driver block, the port is configured as output.

Scaling of Input to Output

I/O Module Output	Block Input Data Type	Scaling
TTL	Double	$< 0.5 = \text{TTL low}$ $\geq 0.5 = \text{TTL high}$

Block Parameters

Channel vector

Enter numbers between 1 and 8 to select the digital output lines used with this port. This driver allows the selection of individual digital output lines in arbitrary order. The number of elements defines the number of digital lines used.

For example, to use all of the digital outputs for one port, enter

[1,2,3,4,5,6,7,8]

Number the lines beginning with 1 even if this board manufacturer starts numbering the lines with 0.

Port

From the list, choose either **A**, **B**, or **C**. The I/O board has an 8255 chip with 3 ports. The **Port** parameter defines which port of the 8255 chip is used for this driver block. Each port has a maximum of 8 digital lines that can be configured as inputs or outputs depending on which driver block is chosen. In each case, one block is required for each port.

Reset vector

The reset vector controls the behavior of the channel at model termination. Enter a scalar or a vector that is the same length as the channel vector. If you specify a scalar value, that setting is replicated over the channel vector. If you specify a value of 1, the corresponding channel is reset to the value specified in the initial value vector. If you specify a value of 0, the channel remains at the last value attained while the model was running.

Initial value vector

The initial value vector contains the initial values (0 or 1) of the output channels. Enter a scalar or a vector that is the same length as the channel vector. If you enter a scalar, that value is replicated as the initial value over the channel vector. The channels are set to these initial values between the time the model is downloaded and the time it is started.

Chip

From the list, choose 1, 2, 3, or 4.

Sample time

Enter the base sample time or a multiple of the base sample time (-1 means sample time is inherited).

PCI slot (-1:autosearch)

If only one board of this type is in the target computer, enter -1 to locate the board.

If two or more boards of this type are in the target computer, enter the bus number and the PCI slot number of the board associated with this driver block. Use the format **[BusNumber, SlotNumber]**.

To determine the bus number and the PCI slot number, type:

```
tg = slrt;  
getPCIInfo(tg, 'installed')
```

External Websites

- www.ni.com

National Instruments PXI-6527

Support for National Instruments PXI-6527 board

Board

National Instruments PXI-6527

General Description

The PXI-6527 is an I/O board with 24 filtered digital input lines and 24 digital output lines. You can individually turn input filtering on or off for each of the 24 input lines, but the same filter time applies to each line.

The Simulink Real-Time block library supports this board with these driver blocks:

- National Instruments PXI-6527 Digital Input
- National Instruments PXI-6527 Digital Output

Board Characteristics

Board name	PXI-6527
Manufacturer	National Instruments
Bus type	PXI
Access method	Memory mapped
Multiple block instance support	Digital I/O: Yes
Multiple board support	Yes

External Websites

- www.ni.com

National Instruments PXI-6527 Digital Input

PXI-6527 Digital Input block

Library

Simulink Real-Time Library for National Instruments

Note

The PXI-6527 has one chip with 3 ports (A,B,C) for digital input. Each port has a maximum of 8 digital I/O lines. Use a separate driver block for each port.

Note: The interrupt on change capability of this board is not used.

Scaling of Input to Output

I/O Module Input	Block Input Data Type	Scaling
OPTO	Double	$< 0.5 = 0$ $\geq 0.5 = 1$

Block Parameters

Channel vector

Enter numbers between 1 and 8 to select the digital input lines used with this port. This driver allows the selection of individual digital input lines in arbitrary order. The number of elements defines the number of digital lines used.

For example, to use all of the digital inputs for one port, enter

[1,2,3,4,5,6,7,8]

Number the lines beginning with 1 even if this board manufacturer starts numbering the lines with 0.

Port

From the list, choose either **A**, **B**, or **C**. The **Port** parameter defines which port is used for this driver block. Each port has a maximum of 8 digital inputs. In each case, one block is required for each port.

The documentation for this board from National Instruments labels these ports 0, 1, and 2.

Filter vector

This is a Boolean vector that selects which input lines to filter. For example, if you enter a **Channel vector** of [1, 3, 5], and you want to filter all three lines, enter

```
[ 1, 1, 1 ]
```

If you want to filter lines 1 and 5, but not line 3, then enter

```
[ 1, 0, 1 ]
```

If the filter vector is a single element, then it is scalar expanded to the same width as the **Channel vector**. In the example above, if the **Filter vector** is [0], it is expanded to [0, 0, 0]. Likewise, if the **Filter vector** is [1] it is expanded to [1, 1, 1].

Filter interval

Enter the time interval the filter uses to determine a stable pulse. If the input pulse is shorter than this interval, it is ignored. The same filter interval applies to each filtered input, and if you filter on more than one digital input block for this board, you must enter the same **Filter interval** for each block.

A reasonable value for the **Filter interval** would be 200 to 300 us.

Sample time

Enter the base sample time or a multiple of the base sample time (- 1 means sample time is inherited).

PCI slot (-1:autosearch)

If only one board of this type is in the target computer, enter - 1 to locate the board.

If two or more boards of this type are in the target computer, enter the bus number and the PCI slot number of the board associated with this driver block. Use the format [**BusNumber**, **SlotNumber**].

To determine the bus number and the PCI slot number, type:

```
tg = slrt;  
getPCIInfo(tg, 'installed')
```

External Websites

- www.ni.com

National Instruments PXI-6527 Digital Output

PXI-6527 Digital Output block

Library

Simulink Real-Time Library for National Instruments

Note

The PXI-6527 has one chip with 3 ports (A,B,C) for digital output. Each port has a maximum of 8 digital output lines. Use a separate driver block for each port.

Scaling of Input to Output

I/O Module Output	Block Output Data Type	Scaling
OPTO	Double	<0.5 = OPTO is OFF, current not flowing ≥ 0.5 = OPTO is ON, current can flow

Block Parameters

Channel vector

Enter numbers between 1 and 8 to select the digital output lines used with this port. This driver allows the selection of individual digital output lines in arbitrary order. The number of elements defines the number of digital lines used.

For example, to use all of the digital outputs for one port, enter

[1,2,3,4,5,6,7,8]

Number the lines beginning with 1 even if this board manufacturer starts numbering the lines with 0.

Port

From the list, choose either **A**, **B**, or **C**. The **Port** parameter defines which port is used for this driver block. Each port has a maximum of 8 digital output lines. In each case, one block is required for each port.

The documentation for this board from National Instruments labels these ports 3, 4, and 5.

Reset vector

The reset vector controls the behavior of the channel at model termination. Enter a scalar or a vector that is the same length as the channel vector. If you specify a scalar value, that setting is replicated over the channel vector. If you specify a value of 1, the corresponding channel is reset to the value specified in the initial value vector. If you specify a value of 0, the channel remains at the last value attained while the model was running.

Initial value vector

The initial value vector contains the initial voltage values for the output channels. Enter a scalar or a vector that is the same length as the channel vector. If you specify a scalar value, that value is replicated as the initial value over the channel vector. The channels are set to the initial values between the time the model is downloaded and the time it is started.

Sample time

Enter the base sample time or a multiple of the base sample time (-1 means sample time is inherited).

PCI slot (-1:autosearch)

If only one board of this type is in the target computer, enter -1 to locate the board.

If two or more boards of this type are in the target computer, enter the bus number and the PCI slot number of the board associated with this driver block. Use the format [**BusNumber**, **SlotNumber**].

To determine the bus number and the PCI slot number, type:

```
tg = slrt;  
getPCIInfo(tg, 'installed')
```

External Websites

- www.ni.com

National Instruments PXI-6704

Support for National Instruments PXI-6704 board

Board

National Instruments PXI-6704

General Description

The PXI-6704 is an I/O board with 16 voltage outputs, 16 current outputs, and 8 digital I/O lines.

The Simulink Real-Time block library supports this board with this driver block:

- National Instruments PXI-6704 Analog Output (D/A)

Board Characteristics

Board name	PXI-6704
Manufacturer	National Instruments
Bus type	PXI
Access method	Memory mapped
Multiple block instance support	No
Multiple board support	Yes

External Websites

- www.ni.com

National Instruments PXI-6704 Analog Output (D/A)

PXI-6704 Analog Output block

Library

Simulink Real-Time Library for National Instruments

Scaling Input to Output

I/O Module Output	Block Input Data Type	Scaling
Volts	Double	1

Block Parameters

Channel vector

Enter numbers between 1 and 32. Channels 1-16 refer to the voltage output channels, and 17-32 the current output channels. The number of elements defines the number of D/A channels used. For example, to use the first and second analog output (D/A) channels, enter

```
[1,2]
```

Number the channels beginning with 1 even if this board manufacturer starts numbering the channels with 0.

Sample time

Enter the base sample time or a multiple of the base sample time (-1 means sample time is inherited).

PCI slot (-1:autosearch)

If only one board of this type is in the target computer, enter -1 to locate the board.

If two or more boards of this type are in the target computer, enter the bus number and the PCI slot number of the board associated with this driver block. Use the format **[BusNumber,SlotNumber]**.

To determine the bus number and the PCI slot number, type:

```
tg = slrt;  
getPCIInfo(tg, 'installed')
```

External Websites

- www.ni.com

NAll, Quanser, Real Time Devices

North Atlantic Industries, Inc.

This topic describes the North Atlantic Industries, Inc. (NAII, formerly Apex) I/O boards supported by the Simulink Real-Time product (www.naii.com).

NAII (Apex) 73LD3

Support for NAII (Apex) 73LD3 positioning sensor I/O board

Board

NAII (Apex) 73LD3

General Description

The NAII (Apex) 73LD3 is an I/O board with up to six input channels for LVDT/RVDT position sensors. The capabilities of this board vary according to its part number designation. There can be 2, 4, or 6 channels. The board might contain an on-board reference. If this reference is present, the supported frequency range is board dependent. The acceptable ranges of values for the block parameters vary according to board type.

The Simulink Real-Time block library supports this board with this driver:

- NAII 73LD3 LVDT/RVDT Converter

The Simulink Real-Time product does not support the digital I/O functionality of this board.

Board Characteristics

Board name	73LD3
Manufacturer	NAII
Bus type	ISA
Access method	I/O mapped
Multiple block instance support	No
Multiple board support	Yes

External Websites

- www.naii.com

NAII 73LD3 LVDT/RVDT Converter

73LD3 LVDT/RVDT Converter block

Library

Simulink Real-Time Library for NAI

Scaling Input to Output

Hardware Input	Block Output Data Type	Scaling
LVDT or RVDT	Double	-32768...32767

Block Parameters

Channel vector

Enter a vector of numbers to specify the input channels. For example, to use the first three analog input (A/D) channels, enter

[1, 2, 3]

The channel numbers can occur in arbitrary order. Number them beginning with 1 even if this board manufacturer numbers them beginning with 0. The maximum allowable channel number can be 2, 4, or 6 depending on the board type.

Signal scale vector

For two-wire systems, enter the transformation ratio so that the full range of motion results in a full scale output signal from -32768 through 32767. For three- or four-wire systems, a setting of 65535 results in a full scale output signal. You can choose this scale factor for each channel independently. If you enter a scalar value, it is applied to all channels.

Velocity scale vector

Enter the velocity (strokes/s or rev/s) that results in an output signal equal to 32767, the maximum 16-bit integer. This scale factor can be chosen for each channel independently. If a scalar value is entered, it is applied to all channels.

Show input ports for dynamic velocity scaling

Select this check box if you want to be able to update the velocity scale vector at run-time. If this check box is selected, the block displays one input port for each output channel selected. These input ports are of width 1 and can be used to update the velocity scale vector dynamically. Even if you select this check box and provide values to the input ports, you still must enter a velocity scale vector to specify the initial values.

Output format

From the list select an output format for all channels:

- **position** — A signal width of 1 that contains the linear position.
- **position-status** — A signal width of 2 that contains the linear position and status.
- **position-velocity** — A signal width of 2 that contains the linear position and velocity.
- **position-velocity-status** — A signal width of 3 that contains the linear position, velocity, and status.

The following notes apply to these formats:

- The position and velocity values are each normalized to be between -1 and 1 .
- Position and velocity are returned in radians and radians per second, respectively.
- The status value is encoded in a 3-bit integer that is returned as a double. The status value consists of the following status information for the channel:
 - Test status, weight of 1
 - Signal status, weight of 2
 - Reference status, weight of 4

Each status is a binary value (0 is OK, 1 is FAILURE). The driver encodes these binary values into a single signal. For example, a status value of 5 (100), means the test status is OK and both signal status and reference status are FAILURE. If the board does not provide a reference/excitation, the test status and reference status do nothing.

When you request a format with status, you also enable the automatic background (bit D2 of the Test Enable Register) testing.

Wiring

From the list, select either 2 wire or 3 or 4 wire.

Excitation frequency (Hz)

Enter the reference frequency of the board in hertz. Note that the possible ranges of reference frequencies depend on the board type and the jumper settings on the board.

Excitation voltage (RMS)

Enter the reference root-mean-square voltage value. Note that the possible ranges of reference voltages depend on the board type.

Sample time

Enter the base sample time or a multiple of the base sample time (- 1 means sample time is inherited).

Base address

Enter the base address of the board. This entry must correspond to the DIP switch setting on the board. For example, if the DIP switch setting is 300 (hexadecimal), enter 0x300.

External Websites

- www.naii.com

NAII (Apex) 73SD3

Support for NAII (Apex) 73SD3 positioning sensor I/O board

Board

NAII (Apex) 73SD3

General Description

The NAII (Apex) 73SD3 is an I/O board with up to six Synchro/Resolver-to-digital channels. The capabilities of this board vary according to its part number designation. There can be 2, 4, or 6 channels. The board might contain an on-board reference. If this reference is present, the supported frequency range is board dependent. The acceptable ranges of values for the block parameters vary according to board type.

The Simulink Real-Time block library supports this board with one driver block:

- NAII 73SD3 Synchro/Resolver

Board Characteristics

Board name	73SD3
Manufacturer	NAII
Bus type	ISA
Access method	Memory mapped
Multiple block instance support	No
Multiple board support	Yes

External Websites

- www.naii.com

NAII 73SD3 Synchro/Resolver

NAII 73SD3 Synchro/Resolver block

Library

Simulink Real-Time Library for NAI

Scaling Input to Output

Hardware Input	Block Output Data Type	Scaling
Synchro or Resolver	Double	position: radians velocity: radians/second

Block Parameters

Channel vector

Enter a vector of numbers to specify the measurement (input) channels. For example, to use the Synchro/Resolver channels 1 and 4, enter

[1, 4]

The channel numbers can occur in arbitrary order. The maximum allowable channel number can be 2, 4, or 6 depending on the board type.

Two-speed ratio vector (1: single speed; greater than 1: two-speed)

Enter a two-speed ratio vector of integers greater than 0. This must be either a scalar or a vector the same length as the channel vector.

The two-speed ratio is normally 1 unless you are using a contiguous odd-even channel pair (such as 3 and 4) as a single two-speed channel. In this case, the two-speed ratio represents the gear ratio between the odd (coarse) and even (fine) channels of the pair. Include only the even member of a two-speed channel pair in the channel vector. For example, if you want to use channels 3 and 4 as a two-speed channel geared in the ratio of 36:1, perform the following:

- Add the value 4 (but not the value 3) to the **Channel vector** value
- Set the corresponding **Two-speed ratio vector** value to 36

High resolution vector (0: 16-bit; 1:24-bit)

Enter a high resolution vector for the channels. This must be a scalar or a vector the same length as the **Channel vector** value. Enter one of the following values:

- 0 — Specifies a 16-bit channel
- 1 — Specifies a 24-bit channel

Note, you can specify high resolution only for the even-numbered channels of a two-speed channel pair. Specifying high resolution incurs a small additional overhead.

Encoder vector (4, 6, 8: commutator poles; 12-16: encoder bits)

Enter a scalar or a vector that is the same length as the **Channel vector** value. The encoder vector controls the encoder or commutation outputs on connector JP5. Enter values according to the following:

- Commutator — Enter values from the set [4 6 8]. These values specify the number of poles for a commutator output.
- Encoder — Enter values from the set [12 13 14 15 16]. These values specify the number of bits for an encoder output.

Output format

From the list select an output format for all channels:

- **position** — A signal width of 1 that contains the linear position.
- **position-status** — A signal width of 2 that contains the linear position and status.
- **position-velocity** — A signal width of 2 the contains the linear position and velocity.
- **position-velocity-status** — A signal width of 3 that contains the linear position, velocity, and status.

The following notes apply to these formats:

- The position and velocity values are each normalized to be between -1 and 1 .
- Position and velocity are returned in radians and radians per second, respectively.

- The status value is encoded in a 3-bit integer that is returned as a double. The status value consists of the following status information for the channel:
 - Test status, weight of 1
 - Signal status, weight of 2
 - Reference status, weight of 4

Each status is a binary value (0 is OK, 1 is FAILURE). The driver encodes these binary values into a single signal. For example, a status value of 5 (100), means the test status is OK and both signal status and reference status are FAILURE. If the board does not provide a reference/excitation, the test status and reference status do nothing.

When you request a format with status, you also enable the automatic background (bit D2 of the Test Enable Register) testing.

Max RPS vector

Enter the maximum measurable velocity (in revolutions per second) for each channel. This value sets the velocity scale for each channel. This value must be a scalar or a vector that is the same length as the **Channel vector** value. Enter positive numbers less than 152.

Show input ports for dynamic max RPS

Select this check box to display an input port for each channel to be used for specifying the maximum RPS dynamically. When you select this check box, the input port signal is internally limited to between 9.5367 and 152.5878 RPS.

Latch all channels before reading position data

Select this check box to latch all channels before reading them. The channels are sampled at the same time. Note that selecting this option incurs a small additional resource overhead.

Excitation frequency (47-10000)

Enter the frequency of the on-board reference/excitation.

Excitation voltage (0, 2-28, or 115)

Enter the voltage of the on-board reference/excitation.

Sample time

Enter the base sample time or a multiple of the base sample time (- 1 means sample time is inherited).

Base address

Enter the base address of the board. This entry must correspond to the DIP switch setting on the board. For example, if the DIP switch setting is 300 (hexadecimal), enter 0x300.

External Websites

- www.naii.com

NAII (Apex) 76LD1

Support for NAII (Apex) 76LD1 positioning sensor I/O board

Board

NAII (Apex) 76LD1

General Description

The NAII (Apex) 76LD1 is an I/O board with up to 12 2-wire or up to six 3-wire or 4-wire stimulus (output) channels. The capabilities of this board vary according to its part number designation. The board might contain an on-board reference. If this reference is present, the supported frequency range is board dependent. The acceptable ranges of values for the block parameters vary according to board type.

The Simulink Real-Time block library supports this board with one driver block:

- NAII 76LD1 L/D

Board Characteristics

Board name	76LD1
Manufacturer	NAII
Bus type	PCI
Access method	Memory mapped
Multiple block instance support	No
Multiple board support	Yes

External Websites

- www.naii.com

NAII 76LD1 L/D

NAII 76LD1 L/D block

Library

Simulink Real-Time Library for NAI

Scaling Input to Output

Hardware Input	Block Output Data Type	Scaling
LVDT or RVDT	Double	-1...1

Block Parameters

Channel vector

Enter a vector of numbers to specify the measurement (input) channels. For example, to use the L/D channels 1 and 3, enter

[1, 3]

The channel numbers can occur in arbitrary order. The maximum allowable channel number can be 0, 2, 4, or 8 depending on the board type.

Wiring vector (2 for 2-wire;3 for 3-wire or 4-wire)

Enter the wire type for each of the channels in **Channel vector**. This entry must be either a scalar or a vector that is the same length as the **Channel vector** entry. Specify the wiring vector as follows:

- 2 — Specifies that the corresponding channel is 2-wire
- 3 — Specifies that the corresponding channel is 3-wire or 4-wire

For example, for a **Channel vector** entry of [1, 3], a **Wiring vector** entry of

[2, 3]

specifies that channel 1 is 2-wire and channel 3 is 3-wire or 4-wire.

Output format

From the list select an output format for all channels:

- **position** — A signal width of 1 that contains the linear position.
- **position-status** — A signal width of 2 that contains the linear position and status.
- **position-velocity** — A signal width of 2 the contains the linear position and velocity.
- **position-velocity-status** — A signal width of 3 that contains the linear position, velocity, and status.

The following notes apply to these formats:

- The position and velocity values are each normalized to be between -1 and 1 .
- Position and velocity are returned in radians and radians per second, respectively.
- The status value is encoded in a 3-bit integer that is returned as a double. The status value consists of the following status information for the channel:
 - Test status, weight of 1
 - Signal status, weight of 2
 - Reference status, weight of 4

Each status is a binary value (0 is OK, 1 is FAILURE). The driver encodes these binary values into a single signal. For example, a status value of 5 (100), means the test status is OK and both signal status and reference status are FAILURE. If the board does not provide a reference/excitation, the test status and reference status do nothing.

When you request a format with status, you also enable the automatic background (bit D2 of the Test Enable Register) testing.

Latch all channels before reading position data

Select this check box to latch all channels before reading them. The channels are sampled at the same time. Note that selecting this option incurs a small additional resource overhead.

Excitation frequency (360-10000)

Enter the frequency for the on-board reference/excitation signal.

Excitation voltage (0, 2-28, or 115)

Enter the voltage of the on-board reference/excitation signal.

Sample time

Enter the base sample time or a multiple of the base sample time (- 1 means sample time is inherited).

PCI slot (-1:autosearch)

If only one board of this type is in the target computer, enter - 1 to locate the board.

If two or more boards of this type are in the target computer, enter the bus number and the PCI slot number of the board associated with this driver block. Use the format [**BusNumber,SlotNumber**].

To determine the bus number and the PCI slot number, type:

```
tg = slrt;  
getPCIInfo(tg, 'installed')
```

External Websites

- www.naii.com

NAII (Apex) 76CL1

Support for NAII (Apex) 76CL1 positioning sensor I/O board

Board

NAII (Apex) 76CL1

Library

Simulink Real-Time Library for NAII

Description

The NAII (Apex) 76CL1 I/O board provides up to eight 2-wire or up to four 3-wire or 4-wire LVDT/RVDT measurement (input) channels. It also provides up to 12 2-wire or up to six 3-wire or 4-wire stimulus (output) channels. The capabilities of this board vary according to its part number designation. The board might contain an on-board reference. If this reference is present, the supported frequency range is board dependent. The acceptable ranges of values for the block parameters vary according to board type.

The Simulink Real-Time block library supports this board with two driver blocks:

- NAII 76CL1 L/D
- NAII 76CL1 D/L

Board Characteristics

Board name	76CL1
Manufacturer	NAII
Bus type	PCI
Access method	Memory mapped
Multiple block instance support	No

Multiple board support

Yes

External Websites

- www.naii.com

NAII 76CL1 L/D

NAII 76CL1 L/D block

Library

Simulink Real-Time Library for NAI

Scaling Input to Output

Hardware Input	Block Output Data Type	Scaling
LVDT or RVDT	Double	-1...1

Block Parameters

Channel vector

Enter a vector of numbers to specify the stimulus (output) channels. For example, to use the L/D channels 1 and 3, enter

[1, 3]

The channel numbers can occur in arbitrary order. The maximum allowable channel number can be 0, 2, 4, or 8 depending on the board type.

Wiring vector (2 for 2-wire;3 for 3-wire or 4-wire)

This must be either a scalar or a vector the same length as the **Channel vector** value. Enter a value of 2 to indicate that the corresponding channel is 2-wire. Enter a value of 3 to indicate the corresponding channel is 3-wire or 4-wire. For example, a **Channel vector** value of [1, 3] and a wiring vector setting of

[2, 3]

indicates that channel 1 is 2-wire and that channel 3 is 3-wire or 4-wire.

Output format

From the list select an output format for all channels:

- **position** — A signal width of 1 that contains the linear position.
- **position-status** — A signal width of 2 that contains the linear position and status.
- **position-velocity** — A signal width of 2 the contains the linear position and velocity.
- **position-velocity-status** — A signal width of 3 that contains the linear position, velocity, and status.

The following notes apply to these formats:

- The position and velocity values are each normalized to be between -1 and 1 .
- Position and velocity are returned in radians and radians per second, respectively.
- The status value is encoded in a 3-bit integer that is returned as a double. The status value consists of the following status information for the channel:
 - Test status, weight of 1
 - Signal status, weight of 2
 - Reference status, weight of 4

Each status is a binary value (0 is OK, 1 is FAILURE). The driver encodes these binary values into a single signal. For example, a status value of 5 (100), means the test status is OK and both signal status and reference status are FAILURE. If the board does not provide a reference/excitation, the test status and reference status do nothing.

When you request a format with status, you also enable the automatic background (bit D2 of the Test Enable Register) testing.

Latch all channels before reading position data

Select this check box to latch all channels before reading them. The channels are sampled at the same time. Note that selecting this option incurs a small additional resource overhead.

Excitation frequency (360-10000)

Enter the frequency of the on-board reference/excitation.

Excitation voltage (0, 2-28, or 115)

Enter the voltage of the on-board reference/excitation.

Sample time

Enter the base sample time or a multiple of the base sample time (- 1 means sample time is inherited).

PCI slot

If only one board of this type is in the target computer, enter - 1 to locate the board.

If two or more boards of this type are in the target computer, enter the bus number and the PCI slot number of the board associated with this driver block. Use the format **[BusNumber,SlotNumber]**. To determine the bus number and the PCI slot number, type:

```
tg = slrt;  
getPCIInfo(tg, 'installed')
```

External Websites

- www.naii.com

NAII 76CL1 D/L

NAII 76CL1 D/L block

Library

Simulink Real-Time Library for NAI

Scaling Input to Output

Hardware Input	Block Output Data Type	Scaling
LVDT/RVDT	Double	-1...1

Block Parameters

Channel vector

Enter a vector of numbers to specify the stimulus (output) channels. For example, to use the D/L channels 1 and 3, enter

[1, 3]

The channel numbers can occur in arbitrary order. The maximum allowable channel number can be 0, 2, 4, or 6 depending on the board type.

If a channel n is configured as a 2-wire channel pair (as specified in the **Wiring vector** parameter), enter only the A subchannels (B is implied) in **Channel vector** as n . The block input expects a vector that contains both channels. For example, if the channels are configured as 2-wire, the **Channel vector** value

[1, 2, 3, 4, 5, 6]

refers to channels 1A/1B, 2A/2B, and so on in that order.

Reset vector

The reset vector controls the behavior of the channel at model termination. Enter a scalar or a vector that is the same length as the channel vector. If you specify a scalar

value, that setting is replicated over the channel vector. If you specify a value of 1, the corresponding channel is reset to the value specified in the initial value vector. If you specify a value of 0, the channel remains at the last value attained while the model was running.

Initial value vector

Enter a scalar or a vector that is the same length as the **Channel vector** value. The initial value vector contains the initial voltage values (in the range -1 to 1) for the output channels. If you specify a scalar value, that value is replicated as the initial value over the channel vector. The channels are set to the initial values between the time the model is downloaded and the time it is started.

Wiring vector (2 for 2-wire;3 for 3-wire or 4-wire)

Enter the wire type for each of the channels in **Channel vector**. This entry must be either a scalar or a vector that is the same length as the **Channel vector** entry. Specify the wiring vector as follows:

- 2 — Specifies that the corresponding channel is 2-wire
- 3 — Specifies that the corresponding channel is 3-wire or 4-wire

If a channel is 2-wire, you can specify the A subchannels (B is implied) (as described for the **Channel vector** parameter).

For example, a **Channel vector** of

[5, 6]

and a **Wiring vector** value of

[2, 3]

indicates that channel 5 is 2-wire and channel 6 is 3-wire or 4-wire. In this channel vector, 5 refers to channels 5A and 5B. Channel 6, because it 3-wire or 4-wire, does not have this distinction. The corresponding input port on the block changes its label to 5AB when you click **Apply** or **OK**.

Transformation ratio vector

Enter the transformation ratio vector for the channels specified in the **Channel vector** value. This entry must be either a scalar or a vector that is the same length as the **Channel vector** value. Enter a ratio within the range 0-2. For 2-wire channels, the transformation ratio applies to both A and B channels.

Show output status port

Select this check box to enable the automatic background (bit D2 of the Test Enable Register) testing. This option displays a status output port labeled **S** when you click **Apply** or **OK**. This port emits a signal with a width of 3. The signal contains the following words for the board:

- Test status
- Signal status
- Excitation status

Excitation frequency (360-10000)

Enter the frequency of the on-board reference/excitation.

Excitation voltage (0, 2-28, or 115)

Enter the voltage of the on-board reference/excitation.

Sample time

Enter the base sample time or a multiple of the base sample time (- 1 means sample time is inherited).

PCI slot

If only one board of this type is in the target computer, enter - 1 to locate the board.

If two or more boards of this type are in the target computer, enter the bus number and the PCI slot number of the board associated with this driver block. Use the format [**BusNumber**, **SlotNumber**]. To determine the bus number and the PCI slot number, type:

```
tg = slrt;  
getPCIInfo(tg, 'installed')
```

External Websites

- www.naii.com

NAII (Apex) 76CS1

Support for NAII (Apex) 76CS1 positioning sensor I/O board

Board

NAII (Apex) 76CS1

General Description

The NAII (Apex) 76CS1 I/O board provides up to 8 synchro/resolver measurement (input, S/D) channels and up to six stimulus (output, D/S) channels. The capabilities of this board vary according to its part number designation. The board might contain an on-board reference. If this reference is present, the supported frequency range is board dependent.

The Simulink Real-Time block library supports this board with two driver blocks:

- NAII 76CS1 S/D
- NAII 76CS1 D/S

Board Characteristics

Board name	76CS1
Manufacturer	NAII
Bus type	PCI
Access method	Memory mapped
Multiple block instance support	No
Multiple board support	Yes

External Websites

- www.naii.com

NAII 76CS1 S/D

NAII 76CS1 S/D block

Library

Simulink Real-Time Library for NAI

Scaling Input to Output

Hardware Input	Block Output Data Type	Scaling
Synchro or Resolver	Double	position: radians velocity: radians/second

Block Parameters

Channel vector

Enter a vector of numbers to specify the input channels. For example, to use the measurement (S/D) channels 1 and 4, enter

[1, 4]

The channel numbers can occur in arbitrary order. The maximum allowable channel number can be 0, 2, 4, or 8 depending on the board type.

Two-speed ratio vector (1: single speed; greater than 1: two-speed)

Enter a two-speed ratio vector of integers greater than 0. This must be either a scalar or a vector the same length as the **Channel vector** value.

The two-speed ratio is normally 1 unless you are using a contiguous odd-even channel pair (such as 3 and 4) as a single two-speed channel. In this case, the two-speed ratio represents the gear ratio between the odd (coarse) and even (fine) channels of the pair. Include only the even member of a two-speed channel pair in the **Channel vector**. For example, if you want to use channels 3 and 4 as a two-speed channel geared in the ratio of 36:1, perform the following:

- Add the value 4 (but not the value 3) to the **Channel vector** value
- Set the corresponding **Two-speed ratio vector** value to 36

High resolution vector (0: 16-bit; 1:24-bit)

Enter a high resolution vector for the channels. This must be a scalar or a vector the same length as the **Channel vector** value. Enter one of the following values:

- 0 — Specifies a 16-bit channel
- 1 — Specifies a 24-bit channel

Note, you can specify high resolution only for the even-numbered channels of a two-speed channel pair. Specifying high resolution incurs a small additional overhead.

Synchro vector

Enter a value to indicate that a channel is synchro or resolver. This value must be a scalar or a vector that is the same length as the **Channel vector** value. For each channel, enter

- 1 to indicate that the corresponding channel is a synchro
- 0 to indicate that it is a resolver

Encoder vector (4, 6, 8: commutator poles; 12-16: encoder bits)

Enter a scalar or a vector that is the same length as the **Channel vector** value. The encoder vector controls the encoder or commutation outputs on connector JP5. Enter values according to the following:

- Commutator — Enter values from the set [4 6 8]. These values specify the number of poles for a commutator output.

Encoder

Enter values from the set [12 13 14 15 16]. These values specify the number of bits for an encoder output.

Output format

From the list select an output format for all channels:

- **position** — A signal width of 1 that contains the linear position.
- **position-status** — A signal width of 2 that contains the linear position and status.

- **position-velocity** — A signal width of 2 the contains the linear position and velocity.
- **position-velocity-status** — A signal width of 3 that contains the linear position, velocity, and status.

The following notes apply to these formats:

- The position and velocity values are each normalized to be between -1 and 1 .
- Position and velocity are returned in radians and radians per second, respectively.
- The status value is encoded in a 3-bit integer that is returned as a double. The status value consists of the following status information for the channel:
 - Test status, weight of 1
 - Signal status, weight of 2
 - Reference status, weight of 4

Each status value is a binary value (0 is OK, 1 is FAILURE). The driver encodes these binary values into a single signal. For example, a status value of 5 (100), means the test status is OK and both signal status and reference status are FAILURE. If the board does not provide a reference/excitation, the test status and reference status do nothing.

When you request a format with status, you also enable the automatic background (bit D2 of the Test Enable Register) testing.

Max RPS vector

Enter the maximum measurable velocity (in revolutions per second) for each channel. This value sets the velocity scale for each channel. This value must be a scalar or a vector that is the same length as the **Channel vector** value. Enter positive numbers less than 152.

Show input ports for dynamic max RPS

Select this check box to display an input port for each channel to be used for specifying the maximum RPS dynamically. When you select this check box, the input port signal is internally limited to between 9.5367 and 152.5878 RPS.

Latch all channels before reading position data

Select this check box to latch all channels before reading them. The channels are sampled at the same time. Note that selecting this option incurs a small additional resource overhead.

Save board setup at model termination (takes 5 seconds)

Select this check box to save the current board settings to the board at model termination. This action takes approximately 5 seconds. Wait for the save action to complete before removing power from the board. Upon save completion, the message

Setup has been saved

appears in the message window on the upper right of the target computer screen.

Excitation frequency (47-10000)

Enter the frequency of the on-board reference/excitation.

Excitation voltage (0, 2-28, or 115)

Enter the voltage of the on-board reference/excitation.

Sample time

Enter the base sample time or a multiple of the base sample time (- 1 means sample time is inherited).

PCI slot

If only one board of this type is in the target computer, enter - 1 to locate the board.

If two or more boards of this type are in the target computer, enter the bus number and the PCI slot number of the board associated with this driver block. Use the format [**BusNumber, SlotNumber**]. To determine the bus number and the PCI slot number, type:

```
tg = slrt;  
getPCIInfo(tg, 'installed')
```

External Websites

- www.naii.com

NAII 76CS1 D/S

NAII 76CS1 D/S block

Library

Simulink Real-Time Library for NAI

Scaling Input to Output

Hardware Input	Block Output Data Type	Scaling
Synchro or Resolver	Double	radians

Block Parameters

Channel vector

Enter a vector of numbers to specify the stimulus (output) channels. For example, to use the D/S channels 1 and 3, enter

[1, 3]

The channel numbers can occur in arbitrary order. The maximum allowable channel number can be 0, 2, 4, or 6 depending on the board type.

Reset vector

The reset vector controls the behavior of the channel at model termination. Enter a scalar or a vector that is the same length as the channel vector. If you specify a scalar value, that setting is replicated over the channel vector. If you specify a value of 1, the corresponding channel is reset to the value specified in the initial value vector. If you specify a value of 0, the channel remains at the last value attained while the model was running.

Initial value vector

Enter a scalar or a vector that is the same length as the channel vector. The initial value vector contains the initial values (in radians) for the output channels. If you specify a scalar value, that value is replicated as the initial value over the channel

vector. The channels are set to the initial values between the time the model is downloaded and the time it is started.

Two-speed ratio vector (1: single speed; greater than 1: two-speed)

Enter a two-speed ratio vector of integers greater than 0. This must be either a scalar or a vector the same length as the channel vector.

The two-speed ratio is normally 1 unless you are using a contiguous odd-even channel pair (such as 3 and 4) as a single two-speed channel. In this case, the two-speed ratio represents the gear ratio between the odd (coarse) and even (fine) channels of the pair. Include only the even member of a two-speed channel pair in the channel vector. For example, if you want to use channels 3 and 4 as a two-speed channel geared in the ratio of 36:1, perform the following:

- Add the value 4 (but not the value 3) to the **Channel vector** value
- Set the corresponding **Two-speed ratio vector** value to **36**

High resolution vector (0: 16-bit; 1:24-bit)

Enter a high resolution vector for the channels. This must be a scalar or a vector the same length as the **Channel vector** value. Enter one of the following values:

- 0 — Specifies a 16-bit channel
- 1 — Specifies a 24-bit channel

Note, you can specify high resolution only for the even-numbered channels of a two-speed channel pair. Specifying high resolution incurs a small additional overhead.

Show output status port

Select this check box to enable the automatic background (bit D2 of the Test Enable Register) testing. This option displays a status output port labeled S when you click **Apply** or **OK**. This port emits a signal with a width of 3. The signal contains the following words for the board:

- Test status
- Signal status
- Excitation status

Excitation frequency (47-10000)

Enter the frequency of the on-board reference/excitation.

Excitation voltage (0, 2-28, or 115)

Enter the voltage of the on-board reference/excitation.

Sample time

Enter the base sample time or a multiple of the base sample time (- 1 means sample time is inherited).

PCI slot

If only one board of this type is in the target computer, enter - 1 to locate the board.

If two or more boards of this type are in the target computer, enter the bus number and the PCI slot number of the board associated with this driver block. Use the format **[BusNumber,SlotNumber]**. To determine the bus number and the PCI slot number, type:

```
tg = slrt;  
getPCIInfo(tg, 'installed')
```

External Websites

- www.naii.com

Quanser

This topic describes the Quanser I/O board supported by the Simulink Real-Time product (www.quanser.com).

Quanser Q4

Support for the Quanser Q4 multifunction measurement and control board.

Board

Quanser Q4

General Description

The Quanser Q4 is a multifunction measurement and control board. It has four 14-bit singled-ended A/D converters, four 12-bit D/A voltage outputs, 16 digital communication channels (each of which can be used for digital input or digital output), four 24-bit encoder inputs, and two 32-bit counter/timers.

The Simulink Real-Time block library supports this board with these driver blocks:

- Quanser Q4 Analog Input
- Quanser Q4 Analog Output
- Quanser Q4 Digital Input
- Quanser Q4 Digital Output
- Quanser Q4 Incremental Encoder
- Quanser Q4 Counter

Board Characteristics

Board name	Q4
Manufacturer	Quanser
Bus type	PCI
Access method	Memory mapped
Multiple block instance support	No
Multiple board support	Yes

External Websites

- www.quanser.com

Quanser Q4 Analog Input

Q4 Analog Input block

Library

Simulink Real-Time Library for Quanser

Scaling of Input to Output

Hardware Input	Block Output Data Type	Scaling
Volts	Double	1

Block Parameters

Channel vector

Enter a vector of numbers between 1 and 4. This driver allows you to enter channel numbers in arbitrary order. For example, to use the first, second and fourth channels, enter

```
[1,2,4]
```

Number the channels beginning with 1 even if this board manufacturer starts numbering the channels with 0. Note that the input range is -10V to 10V for all channels and is not reconfigurable.

Sample time

Enter the base sample time or a multiple of the base sample time (-1 means sample time is inherited).

PCI slot

If only one board of this type is in the target computer, enter -1 to locate the board.

If two or more boards of this type are in the target computer, enter the bus number and the PCI slot number of the board associated with this driver block. Use the

format **[BusNumber,SlotNumber]**. To determine the bus number and the PCI slot number, type:

```
tg = slrt;  
getPCIInfo(tg, 'installed')
```

External Websites

- www.quanser.com

Quanser Q4 Analog Output

Q4 Analog Output block

Library

Simulink Real-Time Library for Quanser

Scaling of Input to Output

Hardware Output	Block Input Data Type	Scaling
Volts	Double	1

Block Parameters

Channel vector

Enter a vector of numbers between 1 and 4. This driver allows you to enter channel numbers in arbitrary order. For example, to use the first, second, and fourth channels, enter

[1,2,4]

Number the channels beginning with 1 even if this board manufacturer starts numbering the channels with 0.

Range vector

Enter a range code for each of the channels in the channel vector. The value can be a scalar or a vector that must be the same length as the channel vector. If you specify a scalar value, that setting is replicated over the channel vector. This board allows the range of each channel to be different.

The following table is a list of the ranges for this driver and the corresponding range codes.

Input Range (V)	Range Code
-10 to +10	-10

Input Range (V)	Range Code
-5 to +5	-5
0 to +10	10

For example, if the first channel is -10 to +10 volts and the second channel is -5 to +5 volts, enter

[-10, -5]

Simultaneous update

Choose this check box to set the outputs to update simultaneously (nontransparent mode).

Note that choosing this check box requires an extra register write per sample time and might cause some loss of performance.

Reset vector

The reset vector controls the behavior of the channel at model termination. Enter a scalar or a vector that is the same length as the channel vector. If you specify a scalar value, that setting is replicated over the channel vector. If you specify a value of 1, the corresponding channel is reset to the value specified in the initial value vector. If you specify a value of 0, the channel remains at the last value attained while the model was running.

Initial value vector

The initial value vector contains the initial voltage values for the output channels. Enter a scalar or a vector that is the same length as the channel vector. If you specify a scalar value, that value is replicated as the initial value over the channel vector. The channels are set to the initial values between the time the model is downloaded and the time it is started.

Sample time

Enter the base sample time or a multiple of the base sample time (-1 means sample time is inherited).

PCI slot

If only one board of this type is in the target computer, enter -1 to locate the board.

If two or more boards of this type are in the target computer, enter the bus number and the PCI slot number of the board associated with this driver block. Use the format [**BusNumber**, **SlotNumber**]. To determine the bus number and the PCI slot number, type:

```
tg = slrt;  
getPCIInfo(tg, 'installed')
```

External Websites

- www.quanser.com

Quanser Q4 Digital Input

Q4 Digital Input block

Library

Simulink Real-Time Library for Quanser

Scaling of Input to Output

Hardware Input	Block Output Data Type	Scaling
TTL	Double	TTL low=0 TTL high=1

Block Parameters

Channel vector

Enter a vector of numbers between 1 and 16. This driver allows you to enter channel numbers in arbitrary order. For example, to use the first, second and fifth digital channels for input, enter

```
[1,2,5]
```

Number the channels beginning with 1 even if this board manufacturer starts numbering the channels with 0.

The Q4 board has 16 digital channels. You can use each of these digital channels for input or output.

Note: If you have a Q4 digital input and digital output block corresponding to the same board (the same PCI slot), do not use the same digital channel number in both blocks.

Sample time

Enter the base sample time or a multiple of the base sample time (- 1 means sample time is inherited).

PCI slot

If only one board of this type is in the target computer, enter - 1 to locate the board.

If two or more boards of this type are in the target computer, enter the bus number and the PCI slot number of the board associated with this driver block. Use the format [**BusNumber**, **SlotNumber**]. To determine the bus number and the PCI slot number, type:

```
tg = slrt;  
getPCIInfo(tg, 'installed')
```

External Websites

- www.quanser.com

Quanser Q4 Digital Output

Q4 Digital Output block

Library

Simulink Real-Time Library for Quanser

Scaling of Input to Output

Hardware Input	Block Output Data Type	Scaling
Volts	Double	1

Block Parameters

Channel vector

Enter a vector of numbers between 1 and 16. This driver allows you to enter channel numbers in arbitrary order. For example, to use the first, second and fifth digital channels for input, enter

```
[1,2,5]
```

Number the channels beginning with 1 even if this board manufacturer starts numbering the channels with 0.

The Q4 board has 16 digital channels. You can use each of these digital channels for input or output.

Note: If you have a Q4 digital input and digital output block corresponding to the same board (the same PCI slot), do not use the same digital channel number in both blocks.

Reset vector

The reset vector controls the behavior of the channel at model termination. Enter a scalar or a vector that is the same length as the channel vector. If you specify a scalar value, that setting is replicated over the channel vector. If you specify a value of 1, the corresponding channel is reset to the value specified in the initial value vector. If you specify a value of 0, the channel remains at the last value attained while the model was running.

Initial value vector

The initial value vector contains the initial voltage values for the output channels. Enter a scalar or a vector that is the same length as the channel vector. If you specify a scalar value, that value is replicated as the initial value over the channel vector. The channels are set to the initial values between the time the model is downloaded and the time it is started.

Sample time

Enter the base sample time or a multiple of the base sample time (- 1 means sample time is inherited).

PCI slot

If only one board of this type is in the target computer, enter - 1 to locate the board.

If two or more boards of this type are in the target computer, enter the bus number and the PCI slot number of the board associated with this driver block. Use the format **[BusNumber, SlotNumber]**. To determine the bus number and the PCI slot number, type:

```
tg = slrt;  
getPCIInfo(tg, 'installed')
```

External Websites

- www.quanser.com

Quanser Q4 Incremental Encoder

Q4 Incremental Encoder block

Library

Simulink Real-Time Library for Quanser

Block Parameters

Channel vector

Enter a vector of numbers between 1 and 4. This driver allows you to enter channel numbers in arbitrary order. For example, to use the first two odd encoder input channels, enter

[1,3]

Number the channels beginning with 1 even if this board manufacturer starts numbering the channels with 0.

Note: If you specify four channels or fewer, it is more efficient to use channels that are all odd or all even.

Initial count vector

The initial value vector contains valid count values to be loaded into the preload register (PR) for the corresponding channel. After a counter decrements to zero, it reloads from the value in the preload register. Enter a scalar or a vector that is the same length as the channel vector. If you specify a scalar value, that value is replicated as initial count value over the channel vector.

Prescale vector

The prescale vector is a base prescale factor for digital filtering. Enter a scalar or a vector that is the same length as the channel vector. If you specify a scalar value, that setting is replicated over the channel vector. This filter clock frequency helps eliminate high frequency noise. Enter a value from 0 to 255. An entry of 0 corresponds to the highest possible available frequency of 16.7 MHz.

Quadrature vector

Enter the quadrature vector. Enter a scalar or a vector that is the same length as the channel vector. If you specify a scalar value, that setting is replicated over the channel vector. The allowable entries are

- 0 — Non-quadrature or normal. The driver treats the A input as count and the B input as direction.
- 1 — 1X quadrature. Counts up or down once per complete cycle of the quadrature signal
- 2 — 2X quadrature. Counts up or down twice per complete cycle of the quadrature signal
- 4 — 4X quadrature. Counts up or down four times per complete cycle of the quadrature signal

Mode vector

Enter the counting mode. Enter a scalar or a vector that is the same length as the channel vector. If you specify a scalar value, that setting is replicated over the channel vector. The allowable entries are

- 0 — Normal. The counter wraps from 0 to 0xFFFFFFFF when decremented and from 0xFFFFFFFF to 0 when incremented.
- 1 — Range Limit. The counter freezes upon reaching 0 from above and upon reaching the preload register (PR) value from below. In both cases, once counting has stopped, the counter resumes only when the count direction reverses.
- 2 — Non-recycle. Counting stops upon overflow or underflow and does not resume.
- 3 — Modulo-N. This mode is similar to normal mode except that the maximum count is specified by the preload register (PR).

Synchronous index vector

Enter the synchronous index vector. Enter a scalar or a vector that is the same length as the channel vector. If you specify a scalar value, that setting is replicated over the channel vector. The allowable entries are

- 0 — Disables index mode. This mode treats the index/load (I/LD) input as a level-sensitive asynchronous input.
- 1 — Enables index mode. This mode treats the index/load (I/LD) input as a level-sensitive synchronous input with the quadrature clocks.

Index polarity vector

Enter the index polarity mode vector. Enter a scalar or a vector that is the same length as the channel vector. If you specify a scalar value, that setting is replicated over the channel vector. The allowable entries are

- 0 — Active Low, for a negative slope
- 1 — Active High, for a positive slope

Preserve counts vector

Enter the preserve counts vector. Enter a scalar or a vector that is the same length as the channel vector. If you specify a scalar value, that setting is replicated over the channel vector. The allowable entries are

- 0 — Do not preserve the current count for the corresponding channel. The driver loads its counter from its preload register (PR) when the model is restarted.
- 1 — Preserve the current count for the corresponding channel when the model is restarted. (Note that the count will be meaningless after power is recycled.)

Sample time

Enter the base sample time or a multiple of the base sample time (- 1 means sample time is inherited).

PCI slot

If only one board of this type is in the target computer, enter - 1 to locate the board.

If two or more boards of this type are in the target computer, enter the bus number and the PCI slot number of the board associated with this driver block. Use the format **[BusNumber, SlotNumber]**. To determine the bus number and the PCI slot number, type:

```
tg = slrt;  
getPCIInfo(tg, 'installed')
```

External Websites

- www.quanser.com

Quanser Q4 Counter

Q4 Counter block

Library

Simulink Real-Time Library for Quanser

Block Parameters

Channel vector

Enter a vector of numbers containing 1 or 2. This driver allows you to enter channel numbers in arbitrary order. Channel 1 references the counter channel, channel 2 references the watchdog channel. For example, to use both channels, enter

[1,2]

Mode vector

Enter the display port mode. Enter a scalar or a vector that is the same length as the channel vector. If you specify a scalar value, that setting is replicated over the channel vector. The allowable entries are

- 0 — Frequency Modulation (FM). Display a single input port for the corresponding channel. This port dynamically specifies the lengths (in 30 nanosecond units) of both the low and high phases of a square wave output over the channel.
- 1 — Pulse Width Modulation (PWM). Display a lo and a hi input port for each corresponding channel. These port dynamically specifies the lengths (in 30 nanosecond units) of the low and high phases respectively of a rectangular wave output over the channel.

Show arm input vector

Enter a scalar or a vector that is the same length as the channel vector. If you specify a scalar value, that setting is replicated over the channel vector. The allowable entries are

- 0 — Do not display the input arm input. The channel is already armed.

- **1** — Display the input arm input for the associated channel. This setting allows a channel to be armed or disarmed. You can use this port to enable or disable the channel output dynamically. To enable or disable the channel output, connect a signal to the input arm input. A signal value of 1 enables the channel output, a value of 0 disables the channel output.

When you disarm a channel, its output is continuously high. When you arm a channel, the corresponding input port(s) control the output, as usual.

The value of an input port is undefined for the time between when a model is downloaded and the time it is started. If an input port is armed, its initial value is determined by the corresponding **Initial low count vector** and **Initial high count vector** values:

- If either the **Initial low count vector** or **Initial high count vector** value is nonzero, the channel will be armed between download time and model start time
- If both the **Initial low count vector** or **Initial high count vector** value is zero, the channel will be disarmed.

Reset vector

The reset vector controls the behavior of the channel at model termination. Enter a scalar or a vector that is the same length as the channel vector. If you specify a scalar value, that setting is replicated over the channel vector. If you specify a value of 1, the corresponding channel is reset to the value specified in the initial value vector. If you specify a value of 0, the channel remains at the last value attained while the model was running.

Initial low count vector

This parameter specifies the initial width (the time after model download and prior to model start) in 30 nanosecond intervals of the low portion of the output signal for the corresponding channel. Enter a scalar or a vector that is the same length as the channel vector. If you specify a scalar value, that setting is replicated over the channel vector.

Initial high count vector

This parameter specifies the initial width (the time after model download and prior to model start) in 30 nanosecond intervals of the high portion of the output signal for the corresponding channel. Enter a scalar or a vector that is the same length as the channel vector. If you specify a scalar value, that setting is replicated over the channel vector.

Sample time

Enter the base sample time or a multiple of the base sample time (- 1 means sample time is inherited).

PCI slot

If only one board of this type is in the target computer, enter - 1 to locate the board.

If two or more boards of this type are in the target computer, enter the bus number and the PCI slot number of the board associated with this driver block. Use the format **[BusNumber, SlotNumber]**. To determine the bus number and the PCI slot number, type:

```
tg = slrt;  
getPCIInfo(tg, 'installed')
```

External Websites

- www.quanser.com

Quanser Q8

Support for the Quanser Q8 multifunction measurement and control board.

Board

Quanser Q8

General Description

The Quanser Q8 is a multifunction measurement and control board. It has eight 14-bit singled-ended A/D converters (supported by two A/D chips with four channels per chip), eight 12-bit D/A voltage outputs, 32 digital communication channels (each of which can be used for digital input or digital output), eight 24-bit encoder inputs, and two 32-bit counter/timers.

The Simulink Real-Time block library supports this board with these driver blocks:

- Quanser Q8 Analog Input
- Quanser Q8 Analog Output
- Quanser Q8 Digital Input
- Quanser Q8 Digital Output
- Quanser Q8 Incremental Encoder
- Quanser Q8 Counter

Board Characteristics

Board name	Q8
Manufacturer	Quanser
Bus type	PCI
Access method	Memory mapped
Multiple block instance support	No
Multiple board support	Yes

External Websites

- www.quanser.com

Quanser Q8 Analog Input

Q8 Analog Input block

Library

Simulink Real-Time Library for Quanser

Scaling of Input to Output

Hardware Input	Block Output Data Type	Scaling
Volts	Double	1

Block Parameters

Channel vector

Enter a vector of numbers between 1 and 8. This driver allows you to enter channel numbers in arbitrary order. For example, to use the first, second and fifth channels, enter

```
[1,2,5]
```

Number the channels beginning with 1 even if this board manufacturer starts numbering the channels with 0. Note that the input range is -10V to 10V for all channels and is not reconfigurable.

Two A/D chips on the Q8 board convert these channels. One A/D chip converts channels 1 to 4, the second A/D chip converts channels 5 to 8. To maximize throughput, balance the conversion load between the two groups of channels. For example, if you want to convert four channels, a channel vector value like the following has one A/D chip convert channels 1 and 2 and the other A/D chip convert channels 5 and 6:

```
[1, 2, 5, 6]
```

Sample time

Enter the base sample time or a multiple of the base sample time (- 1 means sample time is inherited).

PCI slot

If only one board of this type is in the target computer, enter - 1 to locate the board.

If two or more boards of this type are in the target computer, enter the bus number and the PCI slot number of the board associated with this driver block. Use the format **[BusNumber,SlotNumber]**. To determine the bus number and the PCI slot number, type:

```
tg = slrt;  
getPCIInfo(tg, 'installed')
```

External Websites

- www.quanser.com

Quanser Q8 Analog Output

Q8 Analog Output block

Library

Simulink Real-Time Library for Quanser

Scaling of Input to Output

Hardware Output	Block Input Data Type	Scaling
Volts	Double	1

Block Parameters

Channel vector

Enter a vector of numbers between 1 and 8. This driver allows you to enter channel numbers in arbitrary order. For example, to use the first, second and fifth channels, enter

```
[1,2,5]
```

Number the channels beginning with 1 even if this board manufacturer starts numbering the channels with 0.

Two A/D chips on the Q8 board convert these channels. One A/D chip converts channels 1 to 4, the second A/D chip converts channels 5 to 8. To maximize throughput, balance the conversion load between the two groups of channels. For example, if you want to convert four channels, a channel vector value like the following has one A/D chip convert channels 1 and 2 and the other A/D chip convert channels 5 and 6:

```
[1,2,5,6]
```

Range vector

Enter a range code for each of the channels in the channel vector. The value can be a scalar or a vector that must be the same length as the channel vector. If you specify a

scalar value, that setting is replicated over the channel vector. This board allows the range of each channel to be different.

The following table is a list of the ranges for this driver and the corresponding range codes.

Input Range (V)	Range Code
-10 to +10	-10
-5 to +5	-5
0 to +10	10

For example, if the first channel is -10 to +10 volts and the second channel is -5 to +5 volts, enter

[-10, -5]

Simultaneous update

Choose this check box to set the outputs to update simultaneously (nontransparent mode).

Note that choosing this check box requires an extra register write per sample time and might cause some loss of performance.

Reset vector

The reset vector controls the behavior of the channel at model termination. Enter a scalar or a vector that is the same length as the channel vector. If you specify a scalar value, that setting is replicated over the channel vector. If you specify a value of 1, the corresponding channel is reset to the value specified in the initial value vector. If you specify a value of 0, the channel remains at the last value attained while the model was running.

Initial value vector

The initial value vector contains the initial voltage values for the output channels. Enter a scalar or a vector that is the same length as the channel vector. If you specify a scalar value, that value is replicated as the initial value over the channel vector. The channels are set to the initial values between the time the model is downloaded and the time it is started.

Sample time

Enter the base sample time or a multiple of the base sample time (-1 means sample time is inherited).

PCI slot

If only one board of this type is in the target computer, enter -1 to locate the board.

If two or more boards of this type are in the target computer, enter the bus number and the PCI slot number of the board associated with this driver block. Use the format **[BusNumber,SlotNumber]**. To determine the bus number and the PCI slot number, type:

```
tg = slrt;  
getPCIInfo(tg, 'installed')
```

External Websites

- www.quanser.com

Quanser Q8 Digital Input

Q8 Digital Input block

Library

Simulink Real-Time Library for Quanser

Scaling of Input to Output

Hardware Input	Block Output Data Type	Scaling
TTL	Double	TTL low=0 TTL high=1

Block Parameters

Channel vector

Enter a vector of numbers between 1 and 32. This driver allows you to enter channel numbers in arbitrary order. For example, to use the first, second and fifth digital channels for input, enter

```
[1,2,5]
```

Number the channels beginning with 1 even if this board manufacturer starts numbering the channels with 0.

The Q8 board has 32 digital channels. You can use each of these digital channels for input or output.

Note: If you have a Q8 digital input and digital output block corresponding to the same board (the same PCI slot), do not use the same digital channel number in both blocks.

Sample time

Enter the base sample time or a multiple of the base sample time (- 1 means sample time is inherited).

PCI slot

If only one board of this type is in the target computer, enter - 1 to locate the board.

If two or more boards of this type are in the target computer, enter the bus number and the PCI slot number of the board associated with this driver block. Use the format **[BusNumber,SlotNumber]**. To determine the bus number and the PCI slot number, type:

```
tg = slrt;  
getPCIInfo(tg, 'installed')
```

External Websites

- www.quanser.com

Quanser Q8 Digital Output

Q8 Digital Output block

Library

Simulink Real-Time Library for Quanser

Scaling of Input to Output

Hardware Input	Block Output Data Type	Scaling
Volts	Double	1

Block Parameters

Channel vector

Enter a vector of numbers between 1 and 32. This driver allows you to enter channel numbers in arbitrary order. For example, to use the first, second and fifth digital channels for input, enter

```
[1,2,5]
```

Number the channels beginning with 1 even if this board manufacturer starts numbering the channels with 0.

The Q8 board has 32 digital channels. You can use each of these digital channels for input or output.

Note: If you have a Q8 digital input and digital output block corresponding to the same board (the same PCI slot), do not use the same digital channel number in both blocks.

Reset vector

The reset vector controls the behavior of the channel at model termination. Enter a scalar or a vector that is the same length as the channel vector. If you specify a scalar value, that setting is replicated over the channel vector. If you specify a value of 1, the corresponding channel is reset to the value specified in the initial value vector. If you specify a value of 0, the channel remains at the last value attained while the model was running.

Initial value vector

The initial value vector contains the initial voltage values for the output channels. Enter a scalar or a vector that is the same length as the channel vector. If you specify a scalar value, that value is replicated as the initial value over the channel vector. The channels are set to the initial values between the time the model is downloaded and the time it is started.

Sample time

Enter the base sample time or a multiple of the base sample time (- 1 means sample time is inherited).

PCI slot

If only one board of this type is in the target computer, enter - 1 to locate the board.

If two or more boards of this type are in the target computer, enter the bus number and the PCI slot number of the board associated with this driver block. Use the format **[BusNumber, SlotNumber]**. To determine the bus number and the PCI slot number, type:

```
tg = slrt;  
getPCIInfo(tg, 'installed')
```

External Websites

- www.quanser.com

Quanser Q8 Incremental Encoder

Q8 Incremental Encoder block

Library

Simulink Real-Time Library for Quanser

Block Parameters

Channel vector

Enter a vector of numbers between 1 and 8. This driver allows you to enter channel numbers in arbitrary order. For example, to use the first three odd encoder input channels, enter

[1,3,5]

Number the channels beginning with 1 even if this board manufacturer starts numbering the channels with 0.

Note: If you specify four channels or fewer, it is more efficient to use channels that are all odd or all even.

Initial count vector

The initial value vector contains valid count values to be loaded into the preload register (PR) for the corresponding channel. After a counter decrements to zero, it reloads from the value in the preload register. Enter a scalar or a vector that is the same length as the channel vector. If you specify a scalar value, that value is replicated as initial count value over the channel vector.

Prescale vector

The prescale vector is a base prescale factor for digital filtering. Enter a scalar or a vector that is the same length as the channel vector. If you specify a scalar value, that setting is replicated over the channel vector. This filter clock frequency helps eliminate high frequency noise. Enter a value from 0 to 255. An entry of 0 corresponds to the highest possible available frequency of 16.7 MHz.

Quadrature vector

Enter the quadrature vector. Enter a scalar or a vector that is the same length as the channel vector. If you specify a scalar value, that setting is replicated over the channel vector. The allowable entries are

- 0 — Non-quadrature or normal. The driver treats the A input as count and the B input as direction.
- 1 — 1X quadrature. Counts up or down once per complete cycle of the quadrature signal
- 2 — 2X quadrature. Counts up or down twice per complete cycle of the quadrature signal
- 4 — 4X quadrature. Counts up or down four times per complete cycle of the quadrature signal

Mode vector

Enter the counting mode. Enter a scalar or a vector that is the same length as the channel vector. If you specify a scalar value, that setting is replicated over the channel vector. The allowable entries are

- 0 — Normal. The counter wraps from 0 to 0xFFFFFFFF when decremented and from 0xFFFFFFFF to 0 when incremented.
- 1 — Range Limit. The counter freezes upon reaching 0 from above and upon reaching the preload register (PR) value from below. In both cases, once counting has stopped, the counter resumes only when the count direction reverses.
- 2 — Non-recycle. Counting stops upon overflow or underflow and does not resume.
- 3 — Modulo-N. This mode is similar to normal mode except that the maximum count is specified by the preload register (PR).

Synchronous index vector

Enter the synchronous index vector. Enter a scalar or a vector that is the same length as the channel vector. If you specify a scalar value, that setting is replicated over the channel vector. The allowable entries are

- 0 — Disables index mode. This mode treats the index/load (I/LD) input as a level-sensitive asynchronous input.
- 1 — Enables index mode. This mode treats the index/load (I/LD) input as a level-sensitive synchronous input with the quadrature clocks.

Index polarity vector

Enter the index polarity mode vector. Enter a scalar or a vector that is the same length as the channel vector. If you specify a scalar value, that setting is replicated over the channel vector. The allowable entries are

- 0 — Active Low, for a negative slope
- 1 — Active High, for a positive slope

Preserve counts vector

Enter the preserve counts vector. Enter a scalar or a vector that is the same length as the channel vector. If you specify a scalar value, that setting is replicated over the channel vector. The allowable entries are

- 0 — Do not preserve the current count for the corresponding channel. The driver loads its counter from its preload register (PR) when the model is restarted.
- 1 — Preserve the current count for the corresponding channel when the model is restarted. (Note that the count will be meaningless after power is recycled.)

Sample time

Enter the base sample time or a multiple of the base sample time (- 1 means sample time is inherited).

PCI slot

If only one board of this type is in the target computer, enter - 1 to locate the board.

If two or more boards of this type are in the target computer, enter the bus number and the PCI slot number of the board associated with this driver block. Use the format **[BusNumber, SlotNumber]**. To determine the bus number and the PCI slot number, type:

```
tg = slrt;  
getPCIInfo(tg, 'installed')
```

External Websites

- www.quanser.com

Quanser Q8 Counter

Q8 Counter block

Library

Simulink Real-Time Library for Quanser

Block Parameters

Channel vector

Enter a vector of numbers containing 1 or 2. This driver allows you to enter channel numbers in arbitrary order. Channel 1 references the counter channel, channel 2 references the watchdog channel. For example, to use both channels, enter

[1,2]

Mode vector

Enter the display port mode. Enter a scalar or a vector that is the same length as the channel vector. If you specify a scalar value, that setting is replicated over the channel vector. The allowable entries are

- 0 — Frequency Modulation (FM). Display a single input port for the corresponding channel. This port dynamically specifies the lengths (in 30 nanosecond units) of both the low and high phases of a square wave output over the channel.
- 1 — Pulse Width Modulation (PWM). Display a lo and a hi input port for each corresponding channel. These port dynamically specifies the lengths (in 30 nanosecond units) of the low and high phases respectively of a rectangular wave output over the channel.

Show arm input vector

Enter a scalar or a vector that is the same length as the channel vector. If you specify a scalar value, that setting is replicated over the channel vector. The allowable entries are

- 0 — Do not display the input arm input. The channel is already armed.

- 1 — Display the input arm input for the associated channel. This setting allows a channel to be armed or disarmed. You can use this port to enable or disable the channel output dynamically. To enable or disable the channel output, connect a signal to the input arm input. A signal value of 1 enables the channel output, a value of 0 disables the channel output.

When you disarm a channel, its output is continuously high. When you arm a channel, the corresponding input port(s) control the output, as usual.

The value of an input port is undefined for the time between when a model is downloaded and the time it is started. If an input port is armed, its initial value is determined by the corresponding **Initial low count vector** and **Initial high count vector** values:

- If either the **Initial low count vector** or **Initial high count vector** value is nonzero, the channel will be armed between download time and model start time
- If both the **Initial low count vector** or **Initial high count vector** value is zero, the channel will be disarmed.

Reset vector

The reset vector controls the behavior of the channel at model termination. Enter a scalar or a vector that is the same length as the channel vector. If you specify a scalar value, that setting is replicated over the channel vector. If you specify a value of 1, the corresponding channel is reset to the value specified in the initial value vector. If you specify a value of 0, the channel remains at the last value attained while the model was running.

Initial low count vector

This parameter specifies the initial width (the time after model download and prior to model start) in 30 nanosecond intervals of the low portion of the output signal for the corresponding channel. Enter a scalar or a vector that is the same length as the channel vector. If you specify a scalar value, that setting is replicated over the channel vector.

Initial high count vector

This parameter specifies the initial width (the time after model download and prior to model start) in 30 nanosecond intervals of the high portion of the output signal for the corresponding channel. Enter a scalar or a vector that is the same length as the channel vector. If you specify a scalar value, that setting is replicated over the channel vector.

Sample time

Enter the base sample time or a multiple of the base sample time (- 1 means sample time is inherited).

PCI slot

If only one board of this type is in the target computer, enter - 1 to locate the board.

If two or more boards of this type are in the target computer, enter the bus number and the PCI slot number of the board associated with this driver block. Use the format **[BusNumber, SlotNumber]**. To determine the bus number and the PCI slot number, type:

```
tg = slrt;  
getPCIInfo(tg, 'installed')
```

External Websites

- www.quanser.com

Real Time Devices

This topic describes Real Time Devices I/O boards supported by the Simulink Real-Time product (www.rtd.com).

Real Time Devices DM6420

Support for the RTD DM6420 I/O board.

Board

Real Time Devices DM6420

General Description

The DM6420 is an I/O board with 16 single or 8 differential analog input (A/D) channels (12-bit) with a maximum sample rate of 500 kHz, 2 analog output (D/A) channels (12-bit), 8 independent digital I/O lines, 8 dependent digital I/O lines, and 2 counter/timers (16-bit).

The Simulink Real-Time block library supports this board with these driver blocks:

- Real Time Devices DM6420 Analog Input (A/D)
- Real Time Devices DM6420 Analog Output (D/A)
- Real Time Devices DM6420 Digital Input
- Real Time Devices DM6420 Digital Output

Note: The Simulink Real-Time software does not support the counter/timers on this board.

Board Characteristics

Board name	DM6420
Manufacturer	Real Time Devices
Bus type	PC/104
Access method	I/O mapped
Multiple block instance support	No

Multiple board support

Yes

External Websites

- www.rtd.com

Real Time Devices DM6420 Analog Input (A/D)

DM6420 Analog Input block

Library

Simulink Real-Time Library for Real Time Devices

Scaling Input to Output

Hardware Input	Block Output Data Type	Scaling
Volts	Double	1

Block Parameters

Channel vector

Enter numbers between 1 and 16. This driver allows the selection of individual A/D channels in arbitrary order. The number of elements defines the number of A/D channels used.

For example, to use the first, second and fifth channels, enter

```
[1,2,5]
```

Number the channels beginning with 1 even if this board manufacturer starts numbering the channels with 0.

Input coupling vector

Enter either 1 (single-ended) or 2 (differential) for each of the channels in the channel vector to choose the coupling code. The coupling vector must be the same length as the channel vector. This driver allows the coupling of each channel to be different.

For example, if the first and second channels are single-ended and the fifth channel is a differential input, enter

```
[1,1,2]
```

The driver selects a second differential input 8 channels higher than the first channel. In the example above, the driver would select the thirteenth channel as a differential input with the fifth channel.

Range vector

Enter a range code for each of the channels entered in the channel vector. The range vector must be the same length as the channel vector. This driver allows a different range for each channel.

The following table is a list of the ranges for this driver and the corresponding range codes.

Input Range (V)	Range Code
-10 to +10	-10
-5 to +5	-5
0 to +10	10

For example, if the first channel is -10 to + 10 volts and the second and fifth channels are -5 to +5 volts, enter

[-10, -5, -5]

Gain vector

Enter 1, 2, 4, or 8 for each of the channels in the channel vector to choose the gain code of that channel. The gain vector must be the same length as the channel vector. This driver allows the gain of each channel to be different.

Note: While this board has programmable input ranges of ± 5 , ± 10 and 0 to 10, this driver sets the input range to +10, and then lets you select different input ranges by choosing different gains.

The following table is a list of the ranges for this driver given the gain entered in the gain vector.

Gain	Range (V)
1	-10 to 10
2	-5 to +5

Gain	Range (V)
4	-2.5 to 2.5
8	-1.25 to 1.25

Notice that by increasing the gain code the voltage range is decreased. The gain divides the input voltage range.

For example, if the first channel has a gain code of 1 (10 volt range) and the second and fifth channels have a gain code of 2 (5 volt range), enter

[1,2,2]

Sample time

Enter the base sample time or a multiple of the base sample time (- 1 means sample time is inherited).

Base address

Enter the base address of the board. This entry must correspond to the DIP switch setting on the board. For example, if the DIP switch setting is 300 (hexadecimal), enter 0x300.

External Websites

- www.rtd.com

Real Time Devices DM6420 Analog Output (D/A)

DM6420 Analog Output block

Library

Simulink Real-Time Library for Real Time Devices

Scaling of Input to Output

Hardware Output	Block Input Data Type	Scaling
Volts	Double	1

Block Parameters

Channel vector

Enter numbers between 1 and 8 to select the analog output (D/A) channels used. This driver allows the selection of individual channels in arbitrary order. The number of elements defines the number of D/A channels used.

For example, to use the first, second, and fifth channels, enter

```
[1,2,5]
```

Number the channels beginning with 1 even if this board manufacturer starts numbering the channels with 0.

Range vector

Enter a range code for each of the channels entered in the channel vector. The range vector must be the same length as the channel vector. This driver allows a different range for each channel.

The following table is a list of the ranges for this driver and the corresponding range codes.

Input Range (V)	Range Code
-5 to +5	-5
0 to +10	10
0 to +5	5

For example, if the first channel is 0 to + 10 volts and the second and fifth channels are 0 to +5 volts, enter

[10,5,5]

Sample time

Enter the base sample time or a multiple of the base sample time (- 1 means sample time is inherited).

Base address

Enter the base address of the board. This entry must correspond to the DIP switch setting on the board. For example, if the DIP switch setting is 300 (hexadecimal), enter 0x300.

External Websites

- www.rtd.com

Real Time Devices DM6420 Digital Input

DM6420 Digital Input block

Library

Simulink Real-Time Library for Real Time Devices

Note

The DAS1601/16 has an 8255 chip with 3 ports (A,B,C). Each port has a maximum of 8 digital I/O lines that can be configured as inputs or outputs.

Use a separate driver block for each port. By selecting the digital input driver block, the port is configured as input.

Scaling Input to Output

Hardware Input	Block Output Data Type	Scaling
TTL	Double	TTL low = 0.0 TTL high = 1.0

Block Parameters

Channel vector

Enter numbers between 1 and 8 to select the digital input lines used with this port. This driver allows the selection of individual digital input lines in arbitrary order. The number of elements defines the number of digital lines used.

For example, to use all of the digital inputs for one port, enter

```
[1,2,3,4,5,6,7,8]
```

Number the lines beginning with 1 even if this board manufacturer starts numbering the lines with 0.

Port

From the list choose either **A**, **B**, or **C**. The port name defines which port is used for this driver block. Each port has a maximum of 8 digital lines that can be configured as inputs. One block is required for each port used.

Sample time

Enter the base sample time or a multiple of the base sample time (- 1 means sample time is inherited).

Base address

Enter the base address of the board. This entry must correspond to the DIP switch setting on the board. For example, if the DIP switch setting is 300 (hexadecimal), enter **0x300**.

External Websites

- www.rtd.com

Real Time Devices DM6420 Digital Output

DM6420 Digital Output block

Library

Simulink Real-Time Library for Real Time Devices

Note

The DAS1601/16 has an 8255 chip with 2 ports (1,2). Each port has a maximum of 8 digital I/O lines that can be configured as inputs or outputs.

Use a separate driver block for each port. By selecting the digital output driver block, the port is configured as output.

Scaling Input to Output

Hardware Output	Block Input Data Type	Scaling
TTL	Double	$< 0.5 = \text{TTL low}$ $\geq 0.5 = \text{TTL high}$

Block Parameters

Channel vector

Enter numbers between 1 and 8 to select the digital output lines used with this port. This driver allows the selection of individual digital output lines in arbitrary order. The number of elements defines the number of digital lines used.

For example, to use all of the digital outputs for one port, enter

```
[1,2,3,4,5,6,7,8]
```

Number the lines beginning with 1 even if this board manufacturer starts numbering the lines with 0.

Port

From the list choose either 1 or 2. The port name defines which port is used for this driver block. Each port has a maximum of 8 digital lines that can be configured as outputs. One block is required for each port used.

Sample time

Enter the base sample time or a multiple of the base sample time (- 1 means sample time is inherited).

Base address

Enter the base address of the board. This entry must correspond to the DIP switch setting on the board. For example, if the DIP switch setting is 300 (hexadecimal), enter 0x300.

External Websites

- www.rtd.com

Real Time Devices DM6430

Support for the RTD DM6430 I/O board.

Board

Real Time Devices DM6430

General Description

The DM6430 is an PC/104 I/O board with 16 single or 8 differential analog input (A/D) channels (16-bit) with a maximum sample rate of 100 kHz, 1 analog output (D/A) channel (16-bit), 16 digital I/O lines, and 2 counter/timers (16-bit).

The Simulink Real-Time block library supports this board with these driver blocks:

- Real Time Devices DM6430 Analog Input (A/D)
- Real Time Devices DM6430 Analog Output (D/A)
- Real Time Devices DM6430 Digital Input
- Real Time Devices DM6430 Digital Output

Note: The Simulink Real-Time software does not support the counter/timers on this board.

Board Characteristics

Board name	DM6430
Manufacturer	Real Time Devices
Bus type	PC/104
Access method	I/O mapped
Multiple block instance support	No
Multiple board support	Yes

External Websites

- www.rtd.com

Real Time Devices DM6430 Analog Input (A/D)

DM6430 Analog Input block

Library

Simulink Real-Time Library for Real Time Devices

Scaling Input to Output

Hardware Input	Block Output Data Type	Scaling
Volts	Double	1

Block Parameters

Channel vector

Enter numbers between 1 and 16. This driver allows the selection of individual A/D channels in arbitrary order. The number of elements defines the number of A/D channels used.

For example, to use the first, second and fifth channels, enter

[1,2,5]

Number the channels beginning with 1 even if this board manufacturer starts numbering the channels with 0.

Gain vector

Enter 1, 2, 4, or 8 for each of the channels in the channel vector to choose the gain code of that channel. The gain vector must be the same length as the channel vector. This driver allows the gain of each channel to be different.

The following table is a list of the ranges for this driver given the gain entered in the gain vector.

Gain	Range (V)
1	-10 to 10

Gain	Range (V)
2	-5 to +5
4	-2.5 to 2.5
8	-1.25 to 1.25

Notice that by increasing the gain code the voltage range is decreased. The gain divides the input voltage range.

For example, if the first channel has a gain code of 1 (10 volt range) and the second and fifth channels have a gain code of 2 (5 volt range), enter

```
[1,2,2]
```

Input coupling vector

Enter either 1 (single-ended) or 2 (differential) for each of the channels in the channel vector to choose the coupling code. The coupling vector must be the same length as the channel vector. This driver allows the coupling of each channel to be different.

For example, if the first and second channels are single-ended and the fifth channel is a differential input, enter

```
[1,1,2]
```

The driver selects a second differential input 8 channels higher than the first channel. In the example above, the driver would select the thirteenth channel as a differential input with the fifth channel.

Sample time

Enter the base sample time or a multiple of the base sample time (- 1 means sample time is inherited).

Base address

Enter the base address of the board. This entry must correspond to the DIP switch setting on the board. For example, if the DIP switch setting is 300 (hexadecimal), enter 0x300.

External Websites

- www.rtd.com

Real Time Devices DM6430 Analog Output (D/A)

DM6430 Analog Output block

Library

Simulink Real-Time Library for Real Time Devices

Scaling Input to Output

Hardware Output	Block Input Data Type	Scaling
Volts	Double	1

Block Parameters

This board has 2 analog outputs (D/A) with a fixed range of -10 to +10 volts.

Channel vector

Enter 1 or 2 to select the digital output lines used with this port. This driver allows the selection of individual digital input lines in arbitrary order. The number of elements defines the number of digital lines used.

For example, to use all of the digital outputs for one port, enter

[1,2]

Number the lines beginning with 1 even if this board manufacturer starts numbering the lines with 0.

Reset vector

The reset vector controls the behavior of the channel at model termination. Enter a scalar or a vector that is the same length as the channel vector. If you specify a scalar value, that setting is replicated over the channel vector. If you specify a value of 1, the corresponding channel is reset to the value specified in the initial value vector. If you specify a value of 0, the channel remains at the last value attained while the model was running.

Initial value vector

The initial value vector contains the initial voltage values for the output channels.

Enter a scalar or a vector that is the same length as the channel vector. If you specify a scalar value, that value is replicated as the initial value over the channel vector.

The channels are set to the initial values between the time the model is downloaded and the time it is started.

Sample time

Enter the base sample time or a multiple of the base sample time (- 1 means sample time is inherited).

Base address

Enter the base address of the board. This entry must correspond to the DIP switch setting on the board. For example, if the DIP switch setting is 300 (hexadecimal), enter 0x300.

External Websites

- www.rtd.com

Real Time Devices DM6430 Digital Input

DM6430 Digital Input block

Library

Simulink Real-Time Library for Real Time Devices

Note

The DM6430 has an 8255 chip with 2 ports (1,2). Each port has a maximum of 8 digital I/O lines that can be configured as inputs or outputs.

Use a separate driver block for each port. By selecting the digital input driver block, the port is configured as input.

Scaling Input to Output

Hardware Input	Block Output Data Type	Scaling
TTL	Double	TTL low = 0.0 TTL high = 1.0

Block Parameters

Channel vector

Enter numbers between 1 and 8 to select the digital input lines used with this port. This driver allows the selection of individual digital input lines in arbitrary order. The number of elements defines the number of digital lines used.

For example, to use all of the digital inputs for one port, enter

```
[1,2,3,4,5,6,7,8]
```

Number the lines beginning with 1 even if this board manufacturer starts numbering the lines with 0.

Port

From the list choose either 1 or 2. The port name defines which port is used for this driver block. Each port has a maximum of 8 digital lines that can be configured as inputs. One block is required for each port used.

Sample time

Enter the base sample time or a multiple of the base sample time (- 1 means sample time is inherited).

Base address

Enter the base address of the board. This entry must correspond to the DIP switch setting on the board. For example, if the DIP switch setting is 300 (hexadecimal), enter 0x300.

External Websites

- www.rtd.com

Real Time Devices DM6430 Digital Output

DM6430 Digital Output

Library

Simulink Real-Time Library for Real Time Devices

Note

The DM6430 has an 8255 chip with 2 ports (1,2). Each port has a maximum of 8 digital I/O lines that can be configured as inputs or outputs.

Use a separate driver block for each port. By selecting the digital output driver block, the port is configured as output.

Scaling Input to Output

Hardware Output	Block Input Data Type	Scaling
TTL	Double	$< 0.5 = \text{TTL low}$ $\geq 0.5 = \text{TTL high}$

Block Parameters

Channel vector

Enter numbers between 1 and 8 to select the digital output lines used with this port. This driver allows the selection of individual digital output lines in arbitrary order. The number of elements defines the number of digital lines used.

For example, to use all of the digital outputs for one port, enter

```
[1,2,3,4,5,6,7,8]
```

Number the lines beginning with 1 even if this board manufacturer starts numbering the lines with 0.

Port

From the list choose either 1 or 2. The port name defines which port is used for this driver block. Each port has a maximum of 8 digital lines that can be configured as outputs. One block is required for each port used.

Sample time

Enter the base sample time or a multiple of the base sample time (- 1 means sample time is inherited).

Base address

Enter the base address of the board. This entry must correspond to the DIP switch setting on the board. For example, if the DIP switch setting is 300 (hexadecimal), enter 0x300.

External Websites

- www.rtd.com

Real Time Devices DM6604

Support for the RTD DM6604 I/O board.

Board

Real Time Devices DM6604

General Description

The DM6604 is an PC/104 I/O board with 8 analog output (D/A) channels (12-bit), and 24 digital I/O lines.

The Simulink Real-Time block library supports this board with these driver blocks:

- Real Time Devices DM6604 Analog Output (D/A)
- Real Time Devices DM6604 Digital Input
- Real Time Devices DM6604 Digital Output

Board Characteristics

Board name	DM6604
Manufacturer	Real Time Devices
Bus type	PC/104
Access method	I/O mapped
Multiple block instance support	Yes
Multiple board support	Yes

External Websites

- www.rtd.com

Real Time Devices DM6604 Analog Output (D/A)

DM6604 Analog Output block

Library

Simulink Real-Time Library for Real Time Devices

Scaling of Input to Output

Hardware Output	Block Input Data Type	Scaling
Volts	Double	1

Block Parameters

Channel vector

Enter numbers between 1 and 8 to select the analog output (D/A) channels used. This driver allows the selection of individual channels in arbitrary order. The number of elements defines the number of D/A channels used.

For example, to use the first, second, and fifth channels, enter

[1,2,5]

Number the channels beginning with 1 even if this board manufacturer starts numbering the channels with 0.

Range vector

Enter a range code for each of the channels entered in the channel vector. The range vector must be the same length as the channel vector. This driver allows a different range for each channel.

The following table is a list of the ranges for this driver and the corresponding range codes.

Input Range (V)	Range Code
-10 to +10	-10

Input Range (V)	Range Code
-5 to +5	-5
0 to +10	10
0 to +5	5

For example, if the first channel is -10 to +10 volts and the second and fifth channels are 0 to +5 volts, enter

[-10,5,5]

Sample time

Enter the base sample time or a multiple of the base sample time (- 1 means sample time is inherited).

Base address

Enter the base address of the board. This entry must correspond to the DIP switch setting on the board. For example, if the DIP switch setting is 300 (hexadecimal), enter 0x300.

External Websites

- www.rtd.com

Real Time Devices DM6604 Digital Input

DM6604 Digital Input block

Library

Simulink Real-Time Library for Real Time Devices

Block Parameters

Channel vector

Enter numbers between 1 and 8 to select the digital input lines used with this port. This driver allows the selection of individual digital input lines in arbitrary order. The number of elements defines the number of digital lines used.

For example, to use all of the digital inputs for one port, enter

```
[1,2,3,4,5,6,7,8]
```

Number the lines beginning with 1 even if this board manufacturer starts numbering the lines with 0.

Port

From the list choose either A, B, or C. The port name defines which port is used for this driver block. Each port has a maximum of 8 digital lines that can be configured as inputs. One block is required for each port used.

Sample time

Enter the base sample time or a multiple of the base sample time (- 1 means sample time is inherited).

Base address

Enter the base address of the board. This entry must correspond to the DIP switch setting on the board. For example, if the DIP switch setting is 300 (hexadecimal), enter 0x300.

External Websites

- www.rtd.com

Real Time Devices DM6604 Digital Output

DM6604 Digital Output block

Library

Simulink Real-Time Library for Real Time Devices

Block Parameters

Channel vector

Enter numbers between 1 and 8 to select the digital output lines used with this port. This driver allows the selection of individual digital output lines in arbitrary order. The number of elements defines the number of digital lines used.

For example, to use all of the digital outputs for one port, enter

```
[1,2,3,4,5,6,7,8]
```

Number the lines beginning with 1 even if this board manufacturer starts numbering the lines with 0.

Port

From the list choose either A, B, or C. The port name defines which port is used for this driver block. Each port has a maximum of 8 digital lines that can be configured as outputs. One block is required for each port used.

Reset vector

The reset vector controls the behavior of the channel at model termination. Enter a scalar or a vector that is the same length as the channel vector. If you specify a scalar value, that setting is replicated over the channel vector. If you specify a value of 1, the corresponding channel is reset to the value specified in the initial value vector. If you specify a value of 0, the channel remains at the last value attained while the model was running.

Initial value vector

The initial value vector contains the initial values (0 or 1) of the output channels. Enter a scalar or a vector that is the same length as the channel vector. If you enter

a scalar, that value is replicated as the initial value over the channel vector. The channels are set to these initial values between the time the model is downloaded and the time it is started.

Sample time

Enter the base sample time or a multiple of the base sample time (- 1 means sample time is inherited).

Base address

Enter the base address of the board. This entry must correspond to the DIP switch setting on the board. For example, if the DIP switch setting is 300 (hexadecimal), enter 0x300.

External Websites

- www.rtd.com

Real Time Devices DM6804

Support for the RTD DM6804 I/O board.

Board

Real Time Devices DM6804

General Description

The DM6804 is an PC/104 I/O board with 24 digital I/O lines.

It contains one 8255 chip with 3 digital I/O ports.

The Simulink Real-Time block library supports this board with these driver blocks:

- Real Time Devices DM6804 Digital Input
- Real Time Devices DM6804 Digital Output

Board Characteristics

Board name	DM6804
Manufacturer	Real Time Devices
Bus type	PC/104
Access method	I/O mapped
Multiple block instance support	Yes
Multiple board support	Yes

External Websites

- www.rtd.com

Real Time Devices DM6804 Digital Input

DM6804 Digital Input block

Library

Simulink Real-Time Library for Real Time Devices

Note

The DM6804 has an 8255 chip with 3 ports (A, B, C). Each port has a maximum of 8 digital I/O lines that can be configured as inputs or outputs.

Use a separate driver block for each port. By selecting the digital input driver block, the port is configured as input.

Block Parameters

Channel vector

Enter numbers between 1 and 8 to select the digital input lines used with this port. This driver allows the selection of individual digital input lines in arbitrary order. The number of elements defines the number of digital lines used.

For example, to use all of the digital inputs for one port, enter

```
[1,2,3,4,5,6,7,8]
```

Number the lines beginning with 1 even if this board manufacturer starts numbering the lines with 0.

Port

From the list choose either A, B, or C. The port name defines which port is used for this driver block. Each port has a maximum of 8 digital lines that can be configured as inputs. One block is required for each port used.

Sample time

Enter the base sample time or a multiple of the base sample time (-1 means sample time is inherited).

Base address

Enter the base address of the board. This entry must correspond to the DIP switch setting on the board. For example, if the DIP switch setting is 300 (hexadecimal), enter 0x300.

External Websites

- www.rtd.com

Real Time Devices DM6804 Digital Output

DM6804 Digital Output block

Library

Simulink Real-Time Library for Real Time Devices

Note

The DM6804 has an 8255 chip with 3 ports (A, B, C). Each port has a maximum of 8 digital I/O lines that can be configured as inputs or outputs.

Use a separate driver block for each port. By selecting the digital output driver block, the port is configured as output.

Block Parameters

Channel vector

Enter numbers between 1 and 8 to select the digital output lines used with this port. This driver allows the selection of individual digital output lines in arbitrary order. The number of elements defines the number of digital lines used.

For example, to use all of the digital outputs for one port, enter

```
[1,2,3,4,5,6,7,8]
```

Number the lines beginning with 1 even if this board manufacturer starts numbering the lines with 0.

Port

From the list choose either A, B, or C. The port name defines which port is used for this driver block. Each port has a maximum of 8 digital lines that can be configured as outputs. One block is required for each port used.

Reset vector

The reset vector controls the behavior of the channel at model termination. Enter a scalar or a vector that is the same length as the channel vector. If you specify a scalar

value, that setting is replicated over the channel vector. If you specify a value of 1, the corresponding channel is reset to the value specified in the initial value vector. If you specify a value of 0, the channel remains at the last value attained while the model was running.

Initial value vector

The initial value vector contains the initial values (0 or 1) of the output channels. Enter a scalar or a vector that is the same length as the channel vector. If you enter a scalar, that value is replicated as the initial value over the channel vector. The channels are set to these initial values between the time the model is downloaded and the time it is started.

Sample time

Enter the base sample time or a multiple of the base sample time (- 1 means sample time is inherited).

Base address

Enter the base address of the board. This entry must correspond to the DIP switch setting on the board. For example, if the DIP switch setting is 300 (hexadecimal), enter 0x300.

External Websites

- www.rtd.com

Real Time Devices DM6814

Support for the RTD DM6814 I/O board.

Board

Real Time Devices DM6814

General Description

The DM6814 is a 16-bit counting board with three channels. This board typically connects to incremental encoders. Incremental encoders convert physical motion into electrical pulses that can be used to determine velocity, direction, and distance.

Each board also three I/O ports, with each port containing eight digital I/O lines.

The Simulink Real-Time block library supports this board with these driver blocks:

- Real Time Devices DM6814 Incremental Encoder
- Real Time Devices DM6814 Digital Input
- Real Time Devices DM6814 Digital Output

Note: The Simulink Real-Time software does not support the 12 digital input lines on this board.

Board Characteristics

Board name	DM6814
Manufacturer	Real Time Devices
Bus type	PC/104
Access method	I/O mapped
Multiple block instance support	Yes
Multiple board support	Yes

External Websites

- www.rtd.com

Real Time Devices DM6814 Incremental Encoder

DM6814 Incremental Encoder block

Library

Simulink Real-Time Library for Real Time Devices

Scaling Input to Output

Hardware Output	Block Input Data Type	Scaling
TTL	Double	counts

Block Parameters

Encode Channel

From the list choose, 1, 2, or 3. This parameter specifies which channel you use for this block. For the same board (same base address) two blocks cannot have the same channel number.

Counter initial value

Enter the initial value of the counter. The value must be between 1 and $2^{16} - 1$.

Enable counter reset on px.2 (index input)

If this check box is selected, the counter is reset to its initial value (default zero) whenever the incremental encoder is moved over its index mark.

For this purpose you must connect the incremental encoder index output to pin P0.2 for encoder channel 1, P2.2 for channel 2, and P4.2 for channel 3.

Sample time

Enter the base sample time or a multiple of the base sample time (-1 means sample time is inherited).

Base address

Enter the base address of the board. This entry must correspond to the DIP switch setting on the board. For example, if the DIP switch setting is 300 (hexadecimal), enter 0x300.

External Websites

- www.rtd.com

Real Time Devices DM6814 Digital Input

DM6814 Digital Input block

Library

Simulink Real-Time Library for Real Time Devices

Note

You can use only one digital input block per port. You can use an input and an output block for the same port, but then each block must use channels different from those in the other block.

Scaling Input to Output

Hardware Input	Block Output Data Type	Scaling
TTL	Double	TTL low = 0.0 TTL high = 1.0

Block Parameters

Channel Vector

Enter numbers between 1 and 8 to select the digital input lines used with this port. This driver allows the selection of individual digital input lines in arbitrary order. The number of elements defines the number of digital lines used.

For example, to use all the digital inputs for the current port, enter

```
[1,2,3,4,5,6,7,8]
```

Number the lines beginning with 1 even if this board manufacturer starts numbering the lines with 0.

Port

Select port A, B, or C.

Sample time

Enter the base sample time or a multiple of the base sample time (- 1 means sample time is inherited).

Base address

Enter the base address of the board. This entry must correspond to the DIP switch setting on the board. For example, if the DIP switch setting is 300 (hexadecimal), enter 0x300.

External Websites

- www.rtd.com

Real Time Devices DM6814 Digital Output

DM6814 Digital Output block

Library

Simulink Real-Time Library for Real Time Devices

Note

You can configure two digital I/O lines for output. You can use only one digital input block per port. You can use an input and an output block for the same port, but then each block must use channels different from those in the other block.

Scaling Input to Output

Hardware Output	Block Input Data Type	Scaling
TTL	Double	<0.5 = TTL low ≥0.5 = TTL high

Block Parameters

Channel Vector

Enter either numbers 1 or 2 to select the digital output lines you use with this port. This driver allows the selection of individual digital output lines in arbitrary order. The number of elements defines the number of digital lines used.

For example, to use all available digital outputs for the current port, enter

[1,2]

Number the lines beginning with 1 even if this board manufacturer starts numbering the lines with 0.

Port

Select port A, B, or C.

Reset vector

The reset vector controls the behavior of the channel at model termination. Enter a scalar or a vector that is the same length as the channel vector. If you specify a scalar value, that setting is replicated over the channel vector. If you specify a value of 1, the corresponding channel is reset to the value specified in the initial value vector. If you specify a value of 0, the channel remains at the last value attained while the model was running.

Initial value vector

The initial value vector contains the initial values (0 or 1) of the output channels. Enter a scalar or a vector that is the same length as the channel vector. If you enter a scalar, that value is replicated as the initial value over the channel vector. The channels are set to these initial values between the time the model is downloaded and the time it is started.

Sample time

Enter the base sample time or a multiple of the base sample time (- 1 means sample time is inherited).

Base address

Enter the base address of the board. This entry must correspond to the DIP switch setting on the board. For example, if the DIP switch setting is 300 (hexadecimal), enter 0x300.

External Websites

- www.rtd.com

Real Time Devices DM6816

Support for the RTD DM6816 I/O board.

Board

Real Time Devices DM6816

General Description

The DM6816 is an PC/104 I/O board with 9 independent PWM channels, 8-bit resolution, 3 16-bit timer/counters, and an on-board 8 MHz clock.

The Simulink Real-Time block library supports this board with this driver block:

- Real Time Devices DM6816 PWM

Board Characteristics

Board name	DM6816
Manufacturer	Real Time Devices
Bus type	PC/104
Access method	I/O mapped
Multiple block instance support	No
Multiple board support	Yes

External Websites

- www.rtd.com

Real Time Devices DM6816 PWM

DM6816 PWM block

Library

Simulink Real-Time Library for Real Time Devices

Note

As input to the DM6816 PWM block, use a number ranging from 0 to 255. This range corresponds to the duty cycle, where 256 is a duty cycle of 100 percent and 0 is 0 percent. The maximum duty cycle that can be given as an input is $255/256 = 0.996$.

For example, to get a duty cycle of 0.06, input $0.06 * 256 = 15.36$ as the input to the channel. The nearest integer will be used such that the duty cycle will actually be $15/256 = 0.05859$.

Block Parameters

Channel vector

Enter numbers between 1 and 9 to select the PWM channel. This driver allows the selection of individual PWM channels in arbitrary order. The number of elements defines the number of channels used.

For example, to use all of the channels, enter

```
[1,2,3,4,5,6,7,8,9]
```

Number the lines beginning with 1 even if this board manufacturer starts numbering the lines with 0.

Clock source for channels 1, 2, 3

From the list choose either **8 MHz clock** or **Timer 1 output** as the clock source for the channels. By default, it is **Timer 1 output**. This parameter affects channels 1, 2, or 3.

Clock source for channels 4, 5, 6

From the list choose either **8 MHz clock** or **Timer 1 output** as the clock source for the channels. By default, it is **Timer 1 output**. This parameter affects channels 4, 5, or 6.

Clock source for channels 7, 8, 9

From the list choose either **8 MHz clock** or **Timer 1 output** as the clock source for the channels. By default, it is **Timer 1 output**. This parameter affects channels 7, 8, or 9.

Frequency divisors for timers 0, 1, 2

Enter a vector [d0 d1 d2] of integers, with each integer in the range from 2 to 65535. The driver uses these integers as frequency divisors for the timers 0, 1, and 2, respectively. For example, if timer 0 uses the 8 MHz clock as a source, a frequency divisor value of 4 for d0 causes timer 0 to run at 2 MHz (8 MHz/4).

If you specify one integer in the vector, that value applies to all timers.

Sample time

Enter the base sample time or a multiple of the base sample time (-1 means sample time is inherited).

Base address (e.g. 0xd000)

Enter the base address of the board. It is important that this entry corresponds to the DIP-switch settings on the board. For example, if the base address is d000 (hexadecimal), enter 0xd000.

External Websites

- www.rtd.com

Sensoray, Speedgoat, Texas Instruments

Sensoray

This topic describes the Sensoray I/O boards supported by the Simulink Real-Time product (www.sensoray.com).

Sensoray 526

Support for the Sensoray 526 measurement and control board

Board

Sensoray 526

General Description

The Sensoray 526 is a multifunction measurement and control board. It has eight 16-bit analog inputs, four 16-bit analog outputs, four 24-bit quadrature encoder inputs, and eight digital I/O channels.

The Simulink Real-Time software supports this board with these driver blocks:

- Sensoray526 AD
- Sensoray526 Dual AD
- Sensoray526 DA
- Sensoray526 Dual DA
- Sensoray526 DI
- Sensoray526 DO
- Sensoray526 Encoder Input

Board Characteristics

Board name	526
Manufacturer	Sensoray
Bus type	PC/104
Access method	I/O mapped
Multiple block instance support	No
Multiple board support	Yes

External Websites

- www.sensoray.com

Sensoray526 AD

Sensoray526 AD block

Library

Simulink Real-Time Library for Sensoray

Scaling of Input to Output

Hardware Input	Block Output Data Type	Scaling
Volts [-10, +10]	Double [-10,+10]	1

Block Parameters

Channels

Enter a vector of numbers between 1 and 8. Do not repeat channel numbers. For example, to use the first, second and fifth channels, enter

[1, 2, 5]

Number the channels beginning with 1 even if this board manufacturer numbers them beginning with 0.

Sample time

Enter the base sample time or a multiple of the base sample time (- 1 means sample time is inherited).

Base address (i.e. 0x2c0)

Enter the base address of the board. This entry must correspond to the base address DIP switch settings on the board. For example, if the base address is 2C0 (hexadecimal), enter

0x2C0

Note that the Sensoray 526 board ships from the manufacturer with a base address of 0x2C0. If you want to change the base address, see the board manufacturer documentation for allowed values.

External Websites

- www.sensoray.com

Sensoray526 Dual AD

Sensoray526 Dual AD block

Library

Simulink Real-Time Library for Sensoray

Note

The Sensoray526 Dual AD block controls two boards simultaneously. This enables simultaneous conversion for both boards. Each board does not have to wait for the other to finish converting data before starting its own conversion. Acquisition overlaps result in considerable time savings.

Scaling of Input to Output

Hardware Input	Block Output Data Type	Scaling
Volts [-10,+10]	Double [-10,+10]	1

Block Parameters

Board A Channels/Board B Channels

For each board, enter a vector of numbers between 1 and 8. Do not repeat channel numbers. For example, to use the first, second and fifth channels, enter

[1, 2, 5]

Note, for better performance, equally split the active channels between the two boards. If you need eight channels, use four channels on each board.

Number the channels beginning with 1 even if this board manufacturer numbers them beginning with 0.

Sample time

Enter the base sample time or a multiple of the base sample time (- 1 means sample time is inherited).

Board A base address/Board B base address

Enter the base address of the board. This entry must correspond to the base address DIP switch settings on the board. For example, if the base address is 2C0 (hexadecimal), enter

0x2C0

Note that the Sensoray 526 board ships from the manufacturer with a base address of 0x2C0. If you want to change the base address, see the board manufacturer documentation for allowed values. For dual boards, change the base address of at least one of the boards. The boards cannot have the same base address.

External Websites

- www.sensoray.com

Sensoray526 DA

Sensoray526 DA block

Library

Simulink Real-Time Library for Sensoray

Scaling of Input to Output

Hardware Output	Block Input Data Type	Scaling
Volts [10, +10]	Double [10, +10]	1

Block Parameters

Channels

Enter a vector of numbers between 1 and 4. Do not repeat channel numbers. For example, to use the first, second and fourth channels, enter

[1, 2, 4]

Number the channels beginning with 1 even if this board manufacturer numbers them beginning with 0.

Reset vector

The reset vector controls the behavior of the channel at model termination. Enter a scalar or a vector that is the same length as the channel vector. If you specify a scalar value, that setting is replicated over the channel vector. If you specify a value of 1, the corresponding channel is reset to the value specified in the initial value vector. If you specify a value of 0, the channel remains at the last value attained while the model was running.

Initial value vector

The initial value vector contains the initial voltage values for the output channels, used by the block at initialization. If **Reset vector** has a value of 1, the board sets the corresponding channel to the value of the **Initial value vector** when execution

stops. Enter a double precision voltage value in the range -10 to +10. This must be scalar or a vector that is the same length as the channel vector. If you specify a scalar value, that value is replicated as initial value over the channel vector. The channels are set to the initial values between the time the model is downloaded and the time it is started.

Sample time

Enter the base sample time or a multiple of the base sample time (- 1 means sample time is inherited).

Base address

Enter the base address of the board. This entry must correspond to the base address DIP switch settings on the board. For example, if the base address is 2C0 (hexadecimal), enter

0x2C0

Note that the Sensoray 526 board ships from the manufacturer with a base address of 0x2C0. If you want to change the base address, see the board manufacturer documentation for allowed values.

External Websites

- www.sensoray.com

Sensoray526 Dual DA

Sensoray526 Dual DA block

Library

Simulink Real-Time Library for Sensoray

Note

The Sensoray526 Dual AD block controls two boards simultaneously. This enables the block to write the output registers to both boards before the conversion start bits are written on both boards.

Output from the second board changes state approximately 1 to 2 microseconds after the first board. This change is independent of the number of channels in use.

Scaling of Input to Output

Hardware Output	Block Input Data Type	Scaling
Volts [-10,+10]	Double [-10,+10]	1

Block Parameters

Board A Channels/Board B Channels

Enter a vector of numbers between 1 and 4. Do not repeat channel numbers. For example, to use the first, second and fourth channels, enter

[1, 2, 4]

Number the channels beginning with 1 even if this board manufacturer numbers them beginning with 0.

Board A Reset vector/Board B Reset vector

The reset vector controls the behavior of the channel at model termination. Enter a scalar or a vector that is the same length as the channel vector. If you specify a scalar value, that setting is replicated over the channel vector. If you specify a value of 1, the corresponding channel is reset to the value specified in the initial value vector. If you specify a value of 0, the channel remains at the last value attained while the model was running.

Board A Initial value vector/Board B Initial value vector

The initial value vector contains the initial voltage values for the output channels, used by the block at initialization. If **Reset vector** has a value of 1, the board sets the corresponding channel to the value of the **Initial value vector** when execution stops. Enter a double precision voltage value in the range -10 to +10. This must be scalar or a vector that is the same length as the channel vector. If you specify a scalar value, that value is replicated as initial value over the channel vector. The channels are set to the initial values between the time the model is downloaded and the time it is started.

Sample time

Enter the base sample time or a multiple of the base sample time (- 1 means sample time is inherited).

Base address

Enter the base address of the board. This entry must correspond to the base address DIP switch settings on the board. For example, if the base address is 2C0 (hexadecimal), enter

0x2C0

Note that the Sensoray 526 board ships from the manufacturer with a base address of 0x2C0. If you want to change the base address, see the board manufacturer documentation for allowed values. For dual boards, change the base address of at least one of the boards. The boards cannot have the same base address.

External Websites

- www.sensoray.com

Sensoray526 DI

Sensoray526 DI block

Library

Simulink Real-Time Library for Sensoray

Scaling of Input to Output

Hardware Input	Block Output Data Type	Scaling
TTL (0 or +5) volts	Double (0 or 1)	1

Block Parameters

Channels

Enter a vector of numbers between 1 and 8. These are the channels to which the board writes output. Each group, 1 to 4 and 5 to 8, can be either input or output. Do not combine them. For example, if channels 1 to 4 are the input channels, you cannot have output on channel 2. Instead, you can use channels 5 to 8 to be the output channels.

Number the channels beginning with 1 even if this board manufacturer numbers them beginning with 0.

Sample time

Enter the base sample time or a multiple of the base sample time (-1 means sample time is inherited).

Base address

Enter the base address of the board. This entry must correspond to the base address DIP switch settings on the board. For example, if the base address is 2C0 (hexadecimal), enter

0x2C0

Note that the Sensoray 526 board ships from the manufacturer with a base address of 0x2C0. If you want to change the base address, see the board manufacturer documentation for allowed values.

External Websites

- www.sensoray.com

Sensoray526 DO

Sensoray526 DO block

Library

Simulink Real-Time Library for Sensoray

Scaling of Input to Output

Hardware Output	Block Input Data Type	Scaling
TTL (0 or +5) volts	input < 0.5, output = 0 volts input ≥ 0.5, output = 5 volts	1

Block Parameters

Channels

Enter a vector of numbers between 1 and 8. These are the channels to which the board writes output. Each group, 1 to 4 and 5 to 8, can be either input or output. Do not combine them. For example, if channels 1 to 4 are the input channels, you cannot have output on channel 2. Instead, you can use channels 5 to 8 to be the output channels.

Number the channels beginning with 1 even if this board manufacturer numbers them beginning with 0.

Reset vector

The reset vector controls the behavior of the channel at model termination. Enter a scalar or a vector that is the same length as the channel vector. If you specify a scalar value, that setting is replicated over the channel vector. If you specify a value of 1, the corresponding channel is reset to the value specified in the initial value vector. If you specify a value of 0, the channel remains at the last value attained while the model was running.

Initial value vector

The initial value vector contains the initial logic values for the output channels, used by the block at initialization. Enter a 0 or 1. If **Reset vector** has a value of 1, the board sets the corresponding channel to the value of the **Initial value vector** when execution stops. Enter a scalar or a vector that is the same length as the channel vector. If you specify a scalar value, that value is replicated as initial value over the channel vector. The channels are set to the initial values between the time the model is downloaded and the time it is started.

Sample time

Enter the base sample time or a multiple of the base sample time (- 1 means sample time is inherited).

Base address

Enter the base address of the board. This entry must correspond to the base address DIP switch settings on the board. For example, if the base address is 2C0 (hexadecimal), enter

0x2C0

Note that the Sensoray 526 board ships from the manufacturer with a base address of 0x2C0. If you want to change the base address, see the board manufacturer documentation for allowed values.

External Websites

- www.sensoray.com

Sensoray526 Encoder Input

Sensoray526 Encoder Input block

Library

Simulink Real-Time Library for Sensoray

Block Parameters

Channel

From the list, select 1, 2, 3, or 4. This parameter specifies the encoder input channel that this block reads.

Index reset mode

From the list, choose one of the following. This is the event on the index input that resets the counter to the value of **Reset value**.

- Rising edge on index
- Falling edge on index
- Both edges
- None

Reset value

The reset value contains the value of the counter when the event that the **Index reset mode** parameter specifies occurs on the index input.

Initial value

The initial value vector contains the value that is initially loaded into the counter when model execution starts. The counter is set to the initial value between the time the model is downloaded and the time it is started.

Output range

This parameter controls the way the 24-bit integer count is converted to the double precision signal output. From the list, select

- Signed $\pm 2^{23}$ — If the block interprets the high order bit as a sign bit, the output takes values in the range -2^{23} to $(+2^{23})-1$.

- **Unsigned 0 -> $2^{24}-1$** — If the block interprets the 24-bit counter as an unsigned quantity, the output is in the range 0 to $(2^{24})-1$.

Count speed

From the list, select a counting mode. Choose one of the following:

- **1x** — If counting up, count on the rising edge of CLKA. If counting down, count on the falling edge of CLKA.
- **2x** — Count both edges of CLKA, up or down.
- **4x** — Count both edges of both CLKA and CLKB, up or down.

Refer to the board manufacturer documentation for details on the counting mode.

Sample time

Enter the base sample time or a multiple of the base sample time (- 1 means sample time is inherited).

Base address

Enter the base address of the board. This entry must correspond to the base address DIP switch settings on the board. For example, if the base address is 2C0 (hexadecimal), enter

0x2C0

Note that the Sensoray 526 board ships from the manufacturer with a base address of 0x2C0. If you want to change the base address, see the board manufacturer documentation for allowed values.

External Websites

- www.sensoray.com

Speedgoat Support

Speedgoat Real-Time Target Machines

Speedgoat GmbH offers target machines optimized for you to use with Simulink Real-Time software.

You can find Speedgoat target machine configuration documentation here:

www.speedgoat.ch/support/real-time_targets

Speedgoat target machines include:

- Performance — Highest performance, cost-effective system for office or lab.
- Mobile — Small, rugged, fanless, and expandable with up to 14 I/O modules. For mobile and in-vehicle use, and for use in confined areas. Extended temperature support.
- Openframe — Small, rugged, and fanless system mounted on aluminum plate, expandable with up to 14 I/O modules. Extended temperature support.
- Education — Industrial-grade system for use in academic institutions. Very attractive price.
- Modular — Expandable system, for large-scale projects and hardware-in-the-loop (HIL) simulators.
- Audio — System optimized for audio applications, such as hearing aids and car acoustics.
- Automation — System designed for machine cabinet installation, for around-the-clock operation.

You can find Speedgoat target machine product information here:

www.speedgoat.ch/products/real-timetargetmachines

Speedgoat I/O Modules

Speedgoat GmbH offers I/O modules optimized for you to use with Simulink Real-Time software.

You can find Speedgoat I/O module documentation here:

www.speedgoat.ch/support/iomodules

Speedgoat I/O modules include support for:

- Analog I/O: A/D, D/A, sample- or frame-based, with or without isolation, 16–24 bit, voltage and current
- Digital I/O: LVCMOS, TTL, RS422, LVDS
- Multifunctional, reconfigurable FPGA-based:
 - Interrupt
 - PWM generation and capture, pulse patterns
 - Quadrature Decoding and Encoding (Measurement or Simulation)
 - SSI Master and Slave (Measurement and Simulation)
 - SSI2 (Codechamp encoders)
 - EnDat 2.2 (Heidenhain encoders)
 - BiSS (Renishaw encoders)
 - Hiperface
 - SPI Master and Slave, SPI Sniffer
 - I²C Master and Slave
 - Cam and Crank simulation
- LVDT/RVDT and Synchro/Resolver measurement and simulation
- Serial:
 - RS232, RS422, RS485
 - SDLC, HDLC
- Camera Link and UVC-compliant USB video cameras (webcams)
- Shared memory
- Thermocouple, RTD, and Strain Gage measurement and simulation

- IEPE/ICP measurement
- Programmable Resistors and Potentiometers
- SPDT, SPST, and DPST Reed Relays
- Fault insertion

You can find Speedgoat I/O module product information here:

www.speedgoat.ch/products/iomodels

Speedgoat Communication Protocols

Speedgoat GmbH offers communication protocol modules optimized for you to use with Simulink Real-Time software.

You can find Speedgoat protocol module documentation here:

www.speedgoat.ch/support/iomodules

Speedgoat communication protocols include:

- CAN, LIN, SAE J1939, K-Line
- XCP over Ethernet, XCP over CAN
- FlexRay
- MIL-STD-1553, ARINC-429
- EtherCAT Master, EtherCAT Slave, Real-Time UDP, Real-Time Raw Ethernet
- EtherNet/IP™ Scanner (Master) and EtherNet/IP Adapter (Slave)
- PROFINET Master and PROFINET Slave
- PROFIBUS, Modbus TCP, Modbus RTU, Ethernet POWERLINK
- Timing and synchronization: PTP (Precision Time Protocol, IEEE 1588), GPS, IRIG

You can find Speedgoat protocol product information here:

www.speedgoat.ch/products/iomodules

Speedgoat Blocks

Speedgoat IO301

FPGA board providing 64 bidirectional TTL I/O lines

Board

Speedgoat IO301

General Description

The **Speedgoat IO301** is a field-programmable gate array (FPGA) board that provides 64 bidirectional TTL I/O lines. This board is based on a Xilinx® Virtex-II chip with 6912 logic cells. Design tools supporting this chip include the Xilinx ISE Design Suite, version 10.1 (www.xilinx.com).

The default clock rate for this board is 33 MHz.

The Simulink Real-Time block library supports this board with these driver blocks:

- Speedgoat IO301 PCI Setup
- Speedgoat IO301 PCI Read
- Speedgoat IO301 PCI Write

The Speedgoat FPGA I/O board block descriptions are for informational purposes only. The HDL Coder™ HDL Workflow Advisor uses these blocks to generate a Simulink Real-Time interface subsystem. The subsystem mask controls the block parameters. Do not edit the parameters directly.

The Speedgoat IO301 68 Pin Connector Map lists the I/O channel to connector pin assignments.

Speedgoat IO301 68 Pin Connector Map

Connector Pin	I/O Channel	Direction	Transceiver
1	0	Input/Output	TTL
2	1		
3	2	Input/Output	TTL

Connector Pin	I/O Channel	Direction	Transceiver
4	3		
5	4	Input/Output	TTL
6	5		
7	6	Input/Output	TTL
8	7		
9	8	Input/Output	TTL
10	9		
11	10	Input/Output	TTL
12	11		
13	12	Input/Output	TTL
14	13		
15	14	Input/Output	TTL
16	15		
17	Ground		
18	Ground		
19	16	Input/Output	TTL
20	17		
21	18	Input/Output	TTL
22	19		
23	20	Input/Output	TTL
24	21		
25	22	Input/Output	TTL
26	23		
27	24	Input/Output	TTL
28	25		
29	26	Input/Output	TTL
30	27		
31	28	Input/Output	TTL

Connector Pin	I/O Channel	Direction	Transceiver
32	29		
33	30	Input/Output	TTL
34	31		
35	Ground		
36	Ground		
37	32	Input/Output	TTL
38	33		
39	34	Input/Output	TTL
40	35		
41	36	Input/Output	TTL
42	37		
43	38	Input/Output	TTL
44	39		
45	40	Input/Output	TTL
46	41		
47	42	Input/Output	TTL
48	43		
49	44	Input/Output	TTL
50	45		
51	46	Input/Output	TTL
52	47		
53	48	Input/Output	TTL
54	49		
55	50	Input/Output	TTL
56	51		
57	52	Input/Output	TTL
58	53		
59	54	Input/Output	TTL

Connector Pin	I/O Channel	Direction	Transceiver
60	55		
61	56	Input/Output	TTL
62	57		
63	58	Input/Output	TTL
64	59		
65	60	Input/Output	TTL
66	61		
67	62	Input/Output	TTL
68	63		

Board Characteristics

Board name	IO301
Clock rate	24–100 MHz, default 33 MHz
Manufacturer	Speedgoat
Bus type	PCI
Multiple block instance support	Yes
Multiple board support	Yes

Related Examples

- “FPGA Programming and Configuration”

External Websites

- www.speedgoat.ch

Speedgoat IO301 PCI Read

Speedgoat IO301 PCI Read block

Description

The Speedgoat IO301 PCI Read block reads a 32-bit data value from a PCI port offset address. Output is a `uint32` data type.

The Speedgoat FPGA I/O board block descriptions are for informational purposes only. The HDL Coder HDL Workflow Advisor uses these blocks to generate a Simulink Real-Time interface subsystem. The subsystem mask controls the block parameters. Do not edit the parameters directly.

Library

Simulink Real-Time Library for FPGA

Block Parameters

Device index

Enter a number between 0 and 7. The maximum number of allowed boards is 8.

Port name

Enter the FPGA output port name.

Port offset

Enter the PCI register offset address for the ports being read.

Valid offset addresses begin at 0x8000. Each PCI address must be unique and 32-bit aligned, such as `hex2dec('8000')`, `hex2dec('8004')`, and so on.

Port type

Enter the data type of the ports being read (`uint32` (fixed)).

Port dimension

Enter the dimension of the ports being read (*number of addresses to read*). If **Port dimension** is greater than 1, you must use a strobe.

Strobe offset

Enter the PCI register offset address for the signal being used to latch data from the FPGA into the ports being read. If **Strobe offset** is 0, the strobe is not used.

Valid offset addresses begin at 0x8000. Each PCI address must be unique and 32-bit aligned, such as `hex2dec('8000')`, `hex2dec('8004')`, and so on.

Sample time

Enter the base sample time or a multiple of the base sample time (-1 means sample time is inherited).

Related Examples

- “FPGA Programming and Configuration”

External Websites

- www.speedgoat.ch

Speedgoat IO301 PCI Setup

Speedgoat IO301 PCI Setup block

Description

The Speedgoat IO301 PCI Setup block performs the setup and configuration to use the Speedgoat IO301 board.

The Speedgoat FPGA I/O board block descriptions are for informational purposes only. The HDL Coder HDL Workflow Advisor uses these blocks to generate a Simulink Real-Time interface subsystem. The subsystem mask controls the block parameters. Do not edit the parameters directly.

Library

Simulink Real-Time Library for FPGA

Block Parameters

FPGA model/subsystem name

Enter a string to identify the model and subsystem containing the Setup block.

Run FPGA only when Simulink Real-Time runs

Select this check box for the FPGA to execute only when the real-time application is running.

Clear this check box for the FPGA to start immediately after the real-time application is loaded.

Reset FPGA states on start

Select this check box for the FPGA to reset the initial state of the FPGA variables and registers to the default state on startup. Takes effect only when you select the check box **Run FPGA only when Simulink Real-Time runs**.

Clear this check box for the FPGA to retain the end state of the previous execution. To return to the initial state, download the model to the target again and restart the simulation.

The default setting is **Selected**.

Device index

Enter a number between 0 and 7. The maximum number of allowed boards is 8.

PCI slot (-1:autosearch)

If only one board of this type is in the Speedgoat target machine, enter -1 to locate the board.

If two or more boards of this type are in the Speedgoat target machine, enter the bus number and the PCI slot number of the board associated with this driver block. Use the format **[BusNumber,SlotNumber]**.

To determine the bus number and the PCI slot number, type:

```
tg = slrt;  
getPCIInfo(tg, 'installed')
```

Related Examples

- “FPGA Programming and Configuration”

External Websites

- www.speedgoat.ch

Speedgoat IO301 PCI Write

Speedgoat IO301 PCI Write block

Description

The Speedgoat IO301 PCI Write block writes a 32-bit data value to a PCI port offset address. Input must be a `uint32` data type.

The Speedgoat FPGA I/O board block descriptions are for informational purposes only. The HDL Coder HDL Workflow Advisor uses these blocks to generate a Simulink Real-Time interface subsystem. The subsystem mask controls the block parameters. Do not edit the parameters directly.

Library

Simulink Real-Time Library for FPGA

Block Parameters

Device index

Enter a number between 0 and 7. The maximum number of allowed boards is 8.

Port name

Enter the FPGA output port name.

Port offset

Enter the PCI register offset address for the ports being read.

Valid offset addresses begin at 0x8000. Each PCI address must be unique and 32-bit aligned, such as `hex2dec('8000')`, `hex2dec('8004')`, and so on.

Port type

Enter the data type of the ports being read (`uint32` (fixed)).

Port dimension

Enter the dimension of the ports being read (*number of addresses to read*). If **Port dimension** is greater than 1, you must use a strobe.

Strobe offset

Enter the PCI register offset address for the signal being used to latch data from the FPGA into the ports being read. If **Strobe offset** is 0, the strobe is not used.

Valid offset addresses begin at 0x8000. Each PCI address must be unique and 32-bit aligned, such as `hex2dec('8000')`, `hex2dec('8004')`, and so on.

Sample time

Enter the base sample time or a multiple of the base sample time (-1 means sample time is inherited).

Related Examples

- “FPGA Programming and Configuration”

External Websites

- www.speedgoat.ch

Speedgoat IO302

FPGA board providing 32 bidirectional RS-422 I/O lines

Board

Speedgoat IO302

General Description

The **Speedgoat IO302** is a field-programmable gate array (FPGA) board that provides 32 bidirectional RS-422 I/O lines. This board is based on a Xilinx Virtex-II chip with 6912 logic cells. Design tools supporting this chip include the Xilinx ISE Design Suite, version 10.1 (www.xilinx.com).

The default clock rate for this board is 33 MHz.

The Simulink Real-Time block library supports this board with these driver blocks:

- Speedgoat IO302 PCI Setup
- Speedgoat IO302 PCI Read
- Speedgoat IO302 PCI Write

The Speedgoat FPGA I/O board block descriptions are for informational purposes only. The HDL Coder HDL Workflow Advisor uses these blocks to generate a Simulink Real-Time interface subsystem. The subsystem mask controls the block parameters. Do not edit the parameters directly.

The Speedgoat IO302 68 Pin Connector Map lists the I/O channel to connector pin assignments.

Speedgoat IO302 68 Pin Connector Map

Connector Pin	I/O Channel	Direction	Transceiver
1	0(+)	Input/Output	RS-422
2	0(-)		
3	1(+)	Input/Output	RS-422

Connector Pin	I/O Channel	Direction	Transceiver
4	1(-)		
5	2(+)	Input/Output	RS-422
6	2(-)		
7	3(+)	Input/Output	RS-422
8	3(-)		
9	4(+)	Input/Output	RS-422
10	4(-)		
11	5(+)	Input/Output	RS-422
12	5(-)		
13	6(+)	Input/Output	RS-422
14	6(-)		
15	7(+)	Input/Output	RS-422
16	7(-)		
17	Ground		
18	Ground		
19	8(+)	Input/Output	RS-422
20	8(-)		
21	9(+)	Input/Output	RS-422
22	9(-)		
23	10(+)	Input/Output	RS-422
24	10(-)		
25	11(+)	Input/Output	RS-422
26	11(-)		
27	12(+)	Input/Output	RS-422
28	12(-)		
29	13(+)	Input/Output	RS-422
30	13(-)		
31	14(+)	Input/Output	RS-422

Connector Pin	I/O Channel	Direction	Transceiver
32	14(-)		
33	15(+)	Input/Output	RS-422
34	15(-)		
35		Ground	
36		Ground	
37	16(+)	Input/Output	RS-422
38	16(-)		
39	17(+)	Input/Output	RS-422
40	17(-)		
41	18(+)	Input/Output	RS-422
42	18(-)		
43	19(+)	Input/Output	RS-422
44	19(-)		
45	20(+)	Input/Output	RS-422
46	20(-)		
47	21(+)	Input/Output	RS-422
48	21(-)		
49	22(+)	Input/Output	RS-422
50	22(-)		
51	23(+)	Input/Output	RS-422
52	23(-)		
53	24(+)	Input/Output	RS-422
54	24(-)		
55	25(+)	Input/Output	RS-422
56	25(-)		
57	26(+)	Input/Output	RS-422
58	26(-)		
59	27(+)	Input/Output	RS-422

Connector Pin	I/O Channel	Direction	Transceiver
60	27(-)		
61	28(+)	Input/Output	RS-422
62	28(-)		
63	29(+)	Input/Output	RS-422
64	29(-)		
65	30(+)	Input/Output	RS-422
66	30(-)		
67	31(+)	Input/Output	RS-422
68	31(-)		

Board Characteristics

Board name	IO302
Clock rate	24–100 MHz, default 33 MHz
Manufacturer	Speedgoat
Bus type	PCI
Multiple block instance support	Yes
Multiple board support	Yes

Related Examples

- “FPGA Programming and Configuration”

External Websites

- www.speedgoat.ch

Speedgoat IO302 PCI Read

Speedgoat IO302 PCI Read block

Description

The Speedgoat IO302 PCI Read block reads a 32-bit data value from a PCI port offset address. Output is a `uint32` data type.

The Speedgoat FPGA I/O board block descriptions are for informational purposes only. The HDL Coder HDL Workflow Advisor uses these blocks to generate a Simulink Real-Time interface subsystem. The subsystem mask controls the block parameters. Do not edit the parameters directly.

Library

Simulink Real-Time Library for FPGA

Block Parameters

Device index

Enter a number between 0 and 7. The maximum number of allowed boards is 8.

Port name

Enter the FPGA output port name.

Port offset

Enter the PCI register offset address for the ports being read.

Valid offset addresses begin at 0x8000. Each PCI address must be unique and 32-bit aligned, such as `hex2dec('8000')`, `hex2dec('8004')`, and so on.

Port type

Enter the data type of the ports being read (`uint32` (fixed)).

Port dimension

Enter the dimension of the ports being read (*number of addresses to read*). If **Port dimension** is greater than 1, you must use a strobe.

Strobe offset

Enter the PCI register offset address for the signal being used to latch data from the FPGA into the ports being read. If **Strobe offset** is 0, the strobe is not used.

Valid offset addresses begin at 0x8000. Each PCI address must be unique and 32-bit aligned, such as `hex2dec('8000')`, `hex2dec('8004')`, and so on.

Sample time

Enter the base sample time or a multiple of the base sample time (-1 means sample time is inherited).

Related Examples

- “FPGA Programming and Configuration”

External Websites

- www.speedgoat.ch

Speedgoat IO302 PCI Setup

Speedgoat IO302 PCI Setup block

Description

The Speedgoat IO302 PCI Setup block performs the setup and configuration to use the Speedgoat IO302 board.

The Speedgoat FPGA I/O board block descriptions are for informational purposes only. The HDL Coder HDL Workflow Advisor uses these blocks to generate a Simulink Real-Time interface subsystem. The subsystem mask controls the block parameters. Do not edit the parameters directly.

Library

Simulink Real-Time Library for FPGA

Block Parameters

FPGA model/subsystem name

Enter a string to identify the model and subsystem containing the Setup block.

Run FPGA only when Simulink Real-Time runs

Select this check box for the FPGA to execute only when the real-time application is running.

Clear this check box for the FPGA to start immediately after the real-time application is loaded.

Reset FPGA states on start

Select this check box for the FPGA to reset the initial state of the FPGA variables and registers to the default state on startup. Takes effect only when you select the check box **Run FPGA only when Simulink Real-Time runs**.

Clear this check box for the FPGA to retain the end state of the previous execution. To return to the initial state, download the model to the target again and restart the simulation.

The default setting is **Selected**.

Device index

Enter a number between 0 and 7. The maximum number of allowed boards is 8.

Related Examples

- “FPGA Programming and Configuration”

External Websites

- www.speedgoat.ch

Speedgoat IO302 PCI Write

Speedgoat IO302 PCI Write block

Description

The Speedgoat IO302 PCI Write block writes a 32-bit data value to a PCI port offset address. Input must be a `uint32` data type.

The Speedgoat FPGA I/O board block descriptions are for informational purposes only. The HDL Coder HDL Workflow Advisor uses these blocks to generate a Simulink Real-Time interface subsystem. The subsystem mask controls the block parameters. Do not edit the parameters directly.

Library

Simulink Real-Time Library for FPGA

Block Parameters

Device index

Enter a number between 0 and 7. The maximum number of allowed boards is 8.

Port name

Enter the FPGA output port name.

Port offset

Enter the PCI register offset address for the ports being read.

Valid offset addresses begin at 0x8000. Each PCI address must be unique and 32-bit aligned, such as `hex2dec('8000')`, `hex2dec('8004')`, and so on.

Port type

Enter the data type of the ports being read (`uint32 (fixed)`).

Port dimension

Enter the dimension of the ports being read (*number of addresses to read*). If **Port dimension** is greater than 1, you must use a strobe.

Strobe offset

Enter the PCI register offset address for the signal being used to latch data from the FPGA into the ports being read. If **Strobe offset** is 0, the strobe is not used.

Valid offset addresses begin at 0x8000. Each PCI address must be unique and 32-bit aligned, such as `hex2dec('8000')`, `hex2dec('8004')`, and so on.

Sample time

Enter the base sample time or a multiple of the base sample time (-1 means sample time is inherited).

Related Examples

- “FPGA Programming and Configuration”

External Websites

- www.speedgoat.ch

Speedgoat IO303

FPGA board providing 16 bidirectional TTL and 24 bidirectional RS-422 I/O lines

Board

Speedgoat IO303

General Description

The **Speedgoat IO303** is a field-programmable gate array (FPGA) board that provides 16 bidirectional TTL and 24 bidirectional RS-422 I/O lines. This board is based on a Xilinx Virtex-II chip with 6912 logic cells. Design tools supporting this chip include the Xilinx ISE Design Suite, version 10.1 (www.xilinx.com).

The default clock rate for this board is 33 MHz.

The Simulink Real-Time block library supports this board with these driver blocks:

- Speedgoat IO303 PCI Setup
- Speedgoat IO303 PCI Read
- Speedgoat IO303 PCI Write

The Speedgoat FPGA I/O board block descriptions are for informational purposes only. The HDL Coder HDL Workflow Advisor uses these blocks to generate a Simulink Real-Time interface subsystem. The subsystem mask controls the block parameters. Do not edit the parameters directly.

The Speedgoat IO303 68 Pin Connector Map lists the I/O channel to connector pin assignments.

Speedgoat IO303 68 Pin Connector Map

Connector Pin	I/O Channel	Direction	Transceiver
1	0	Input/Output	TTL
2	1		
3	2	Input/Output	TTL

Connector Pin	I/O Channel	Direction	Transceiver
4	3		
5	4	Input/Output	TTL
6	5		
7	6	Input/Output	TTL
8	7		
9	8	Input/Output	TTL
10	9		
11	10	Input/Output	TTL
12	11		
13	12	Input/Output	TTL
14	13		
15	14	Input/Output	TTL
16	15		
17	Ground		
18	Ground		
19	0(+)	Input/Output	RS-422
20	0(-)		
21	1(+)	Input/Output	RS-422
22	1(-)		
23	2(+)	Input/Output	RS-422
24	2(-)		
25	3(+)	Input/Output	RS-422
26	3(-)		
27	4(+)	Input/Output	RS-422
28	4(-)		
29	5(+)	Input/Output	RS-422
30	5(-)		
31	6(+)	Input/Output	RS-422

Connector Pin	I/O Channel	Direction	Transceiver
32	6(-)		
33	7(+)	Input/Output	RS-422
34	7(-)		
35	Ground		
36	Ground		
37	8(+)	Input/Output	RS-422
38	8(-)		
39	9(+)	Input/Output	RS-422
40	9(-)		
41	10(+)	Input/Output	RS-422
42	10(-)		
43	11(+)	Input/Output	RS-422
44	11(-)		
45	12(+)	Input/Output	RS-422
46	12(-)		
47	13(+)	Input/Output	RS-422
48	13(-)		
49	14(+)	Input/Output	RS-422
50	14(-)		
51	15(+)	Input/Output	RS-422
52	15(-)		
53	16(+)	Input/Output	RS-422
54	16(-)		
55	17(+)	Input/Output	RS-422
56	17(-)		
57	18(+)	Input/Output	RS-422
58	18(-)		
59	19(+)	Input/Output	RS-422

Connector Pin	I/O Channel	Direction	Transceiver
60	19(-)		
61	20(+)	Input/Output	RS-422
62	20(-)		
63	21(+)	Input/Output	RS-422
64	21(-)		
65	22(+)	Input/Output	RS-422
66	22(-)		
67	23(+)	Input/Output	RS-422
68	23(-)		

Board Characteristics

Board name	IO303
Clock rate	24–100 MHz, default 33 MHz
Manufacturer	Speedgoat
Bus type	PCI
Multiple block instance support	Yes
Multiple board support	Yes

Related Examples

- “FPGA Programming and Configuration”

External Websites

- www.speedgoat.ch

Speedgoat IO303 PCI Read

Speedgoat IO303 PCI Read block

Description

The Speedgoat IO303 PCI Read block reads a 32-bit data value from a PCI port offset address. Output is a `uint32` data type.

The Speedgoat FPGA I/O board block descriptions are for informational purposes only. The HDL Coder HDL Workflow Advisor uses these blocks to generate a Simulink Real-Time interface subsystem. The subsystem mask controls the block parameters. Do not edit the parameters directly.

Library

Simulink Real-Time Library for FPGA

Block Parameters

Device index

Enter a number between 0 and 7. The maximum number of allowed boards is 8.

Port name

Enter the FPGA output port name.

Port offset

Enter the PCI register offset address for the ports being read.

Valid offset addresses begin at 0x8000. Each PCI address must be unique and 32-bit aligned, such as `hex2dec('8000')`, `hex2dec('8004')`, and so on.

Port type

Enter the data type of the ports being read (`uint32` (fixed)).

Port dimension

Enter the dimension of the ports being read (*number of addresses to read*). If **Port dimension** is greater than 1, you must use a strobe.

Strobe offset

Enter the PCI register offset address for the signal being used to latch data from the FPGA into the ports being read. If **Strobe offset** is 0, the strobe is not used.

Valid offset addresses begin at 0x8000. Each PCI address must be unique and 32-bit aligned, such as `hex2dec('8000')`, `hex2dec('8004')`, and so on.

Sample time

Enter the base sample time or a multiple of the base sample time (-1 means sample time is inherited).

Related Examples

- “FPGA Programming and Configuration”

External Websites

- www.speedgoat.ch

Speedgoat IO303 PCI Setup

Speedgoat IO303 PCI Setup block

Description

The Speedgoat IO303 PCI Setup block performs the setup and configuration to use the Speedgoat IO303 board.

The Speedgoat FPGA I/O board block descriptions are for informational purposes only. The HDL Coder HDL Workflow Advisor uses these blocks to generate a Simulink Real-Time interface subsystem. The subsystem mask controls the block parameters. Do not edit the parameters directly.

Library

Simulink Real-Time Library for FPGA

Block Parameters

FPGA model/subsystem name

Enter a string to identify the model and subsystem containing the Setup block.

Run FPGA only when Simulink Real-Time runs

Select this check box for the FPGA to execute only when the real-time application is running.

Clear this check box for the FPGA to start immediately after the real-time application is loaded.

Reset FPGA states on start

Select this check box for the FPGA to reset the initial state of the FPGA variables and registers to the default state on startup. Takes effect only when you select the check box **Run FPGA only when Simulink Real-Time runs**.

Clear this check box for the FPGA to retain the end state of the previous execution. To return to the initial state, download the model to the target again and restart the simulation.

The default setting is **Selected**.

Device index

Enter a number between 0 and 7. The maximum number of allowed boards is 8.

PCI slot (-1:autosearch)

If only one board of this type is in the Speedgoat target machine, enter -1 to locate the board.

If two or more boards of this type are in the Speedgoat target machine, enter the bus number and the PCI slot number of the board associated with this driver block. Use the format **[BusNumber,SlotNumber]**.

To determine the bus number and the PCI slot number, type:

```
tg = slrt;  
getPCIInfo(tg, 'installed')
```

Related Examples

- “FPGA Programming and Configuration”

External Websites

- www.speedgoat.ch

Speedgoat IO303 PCI Write

Speedgoat IO303 PCI Write block

Description

The Speedgoat IO303 PCI Write block writes a 32-bit data value to a PCI port offset address. Input must be a `uint32` data type.

The Speedgoat FPGA I/O board block descriptions are for informational purposes only. The HDL Coder HDL Workflow Advisor uses these blocks to generate a Simulink Real-Time interface subsystem. The subsystem mask controls the block parameters. Do not edit the parameters directly.

Library

Simulink Real-Time Library for FPGA

Block Parameters

Device index

Enter a number between 0 and 7. The maximum number of allowed boards is 8.

Port name

Enter the FPGA output port name.

Port offset

Enter the PCI register offset address for the ports being read.

Valid offset addresses begin at 0x8000. Each PCI address must be unique and 32-bit aligned, such as `hex2dec('8000')`, `hex2dec('8004')`, and so on.

Port type

Enter the data type of the ports being read (`uint32` (fixed)).

Port dimension

Enter the dimension of the ports being read (*number of addresses to read*). If **Port dimension** is greater than 1, you must use a strobe.

Strobe offset

Enter the PCI register offset address for the signal being used to latch data from the FPGA into the ports being read. If **Strobe offset** is 0, the strobe is not used.

Valid offset addresses begin at 0x8000. Each PCI address must be unique and 32-bit aligned, such as `hex2dec('8000')`, `hex2dec('8004')`, and so on.

Sample time

Enter the base sample time or a multiple of the base sample time (-1 means sample time is inherited).

Related Examples

- “FPGA Programming and Configuration”

External Websites

- www.speedgoat.ch

Speedgoat IO311

FPGA board providing 64 bidirectional TTL I/O lines

Board

Speedgoat IO311

General Description

The Speedgoat IO311 is a field-programmable gate array (FPGA) board that provides 64 bidirectional TTL I/O lines. This board is based on a Xilinx Virtex-II chip with 24192 logic cells. Design tools supporting this chip include the Xilinx ISE Design Suite, version 10.1 (www.xilinx.com).

The default clock rate for this board is 33 MHz.

The Simulink Real-Time block library supports this board with these driver blocks:

- Speedgoat IO311 PCI Setup
- Speedgoat IO311 PCI Read
- Speedgoat IO311 PCI Write

The Speedgoat FPGA I/O board block descriptions are for informational purposes only. The HDL Coder HDL Workflow Advisor uses these blocks to generate a Simulink Real-Time interface subsystem. The subsystem mask controls the block parameters. Do not edit the parameters directly.

The Speedgoat IO311 68 Pin Connector Map lists the I/O channel to connector pin assignments.

Speedgoat IO311 68 Pin Connector Map

Connector Pin	I/O Channel	Direction	Transceiver
1	0	Input/Output	TTL
2	1		
3	2	Input/Output	TTL

Connector Pin	I/O Channel	Direction	Transceiver
4	3		
5	4	Input/Output	TTL
6	5		
7	6	Input/Output	TTL
8	7		
9	8	Input/Output	TTL
10	9		
11	10	Input/Output	TTL
12	11		
13	12	Input/Output	TTL
14	13		
15	14	Input/Output	TTL
16	15		
17	Ground		
18	Ground		
19	16	Input/Output	TTL
20	17		
21	18	Input/Output	TTL
22	19		
23	20	Input/Output	TTL
24	21		
25	22	Input/Output	TTL
26	23		
27	24	Input/Output	TTL
28	25		
29	26	Input/Output	TTL
30	27		
31	28	Input/Output	TTL

Connector Pin	I/O Channel	Direction	Transceiver
32	29		
33	30	Input/Output	TTL
34	31		
35	Ground		
36	Ground		
37	32	Input/Output	TTL
38	33		
39	34	Input/Output	TTL
40	35		
41	36	Input/Output	TTL
42	37		
43	38	Input/Output	TTL
44	39		
45	40	Input/Output	TTL
46	41		
47	42	Input/Output	TTL
48	43		
49	44	Input/Output	TTL
50	45		
51	46	Input/Output	TTL
52	47		
53	48	Input/Output	TTL
54	49		
55	50	Input/Output	TTL
56	51		
57	52	Input/Output	TTL
58	53		
59	54	Input/Output	TTL

Connector Pin	I/O Channel	Direction	Transceiver
60	55		
61	56	Input/Output	TTL
62	57		
63	58	Input/Output	TTL
64	59		
65	60	Input/Output	TTL
66	61		
67	62	Input/Output	TTL
68	63		

Board Characteristics

Board name	IO311
Clock rate	24–100 MHz, default 33 MHz
Manufacturer	Speedgoat
Bus type	PCI
Multiple block instance support	Yes
Multiple board support	Yes

Related Examples

- “FPGA Programming and Configuration”

External Websites

- www.speedgoat.ch

Speedgoat IO311 PCI Read

Speedgoat IO311 PCI Read block

Description

The Speedgoat IO311 PCI Read block reads a 32-bit data value from a PCI port offset address. Output is a `uint32` data type.

The Speedgoat FPGA I/O board block descriptions are for informational purposes only. The HDL Coder HDL Workflow Advisor uses these blocks to generate a Simulink Real-Time interface subsystem. The subsystem mask controls the block parameters. Do not edit the parameters directly.

Library

Simulink Real-Time Library for FPGA

Block Parameters

Device index

Enter a number between 0 and 7. The maximum number of allowed boards is 8.

Port name

Enter the FPGA output port name.

Port offset

Enter the PCI register offset address for the ports being read.

Valid offset addresses begin at 0x8000. Each PCI address must be unique and 32-bit aligned, such as `hex2dec('8000')`, `hex2dec('8004')`, and so on.

Port type

Enter the data type of the ports being read (`uint32` (fixed)).

Port dimension

Enter the dimension of the ports being read (*number of addresses to read*). If **Port dimension** is greater than 1, you must use a strobe.

Strobe offset

Enter the PCI register offset address for the signal being used to latch data from the FPGA into the ports being read. If **Strobe offset** is 0, the strobe is not used.

Valid offset addresses begin at 0x8000. Each PCI address must be unique and 32-bit aligned, such as `hex2dec('8000')`, `hex2dec('8004')`, and so on.

Sample time

Enter the base sample time or a multiple of the base sample time (-1 means sample time is inherited).

Related Examples

- “FPGA Programming and Configuration”

External Websites

- www.speedgoat.ch

Speedgoat IO311 PCI Setup

Speedgoat IO311 PCI Setup block

Description

The Speedgoat IO311 PCI Setup block performs the setup and configuration to use the Speedgoat IO311 board.

The Speedgoat FPGA I/O board block descriptions are for informational purposes only. The HDL Coder HDL Workflow Advisor uses these blocks to generate a Simulink Real-Time interface subsystem. The subsystem mask controls the block parameters. Do not edit the parameters directly.

Library

Simulink Real-Time Library for FPGA

Block Parameters

FPGA model/subsystem name

Enter a string to identify the model and subsystem containing the Setup block.

Run FPGA only when Simulink Real-Time runs

Select this check box for the FPGA to execute only when the real-time application is running.

Clear this check box for the FPGA to start immediately after the real-time application is loaded.

Reset FPGA states on start

Select this check box for the FPGA to reset the initial state of the FPGA variables and registers to the default state on startup. Takes effect only when you select the check box **Run FPGA only when Simulink Real-Time runs**.

Clear this check box for the FPGA to retain the end state of the previous execution. To return to the initial state, download the model to the target again and restart the simulation.

The default setting is **Selected**.

Device index

Enter a number between 0 and 7. The maximum number of allowed boards is 8.

PCI slot (-1:autosearch)

If only one board of this type is in the Speedgoat target machine, enter -1 to locate the board.

If two or more boards of this type are in the Speedgoat target machine, enter the bus number and the PCI slot number of the board associated with this driver block. Use the format **[BusNumber,SlotNumber]**.

To determine the bus number and the PCI slot number, type:

```
tg = slrt;  
getPCIInfo(tg, 'installed')
```

Related Examples

- “FPGA Programming and Configuration”

External Websites

- www.speedgoat.ch

Speedgoat IO311 PCI Write

Speedgoat IO311 PCI Write block

Description

The Speedgoat IO311 PCI Write block writes a 32-bit data value to a PCI port offset address. Input must be a `uint32` data type.

The Speedgoat FPGA I/O board block descriptions are for informational purposes only. The HDL Coder HDL Workflow Advisor uses these blocks to generate a Simulink Real-Time interface subsystem. The subsystem mask controls the block parameters. Do not edit the parameters directly.

Library

Simulink Real-Time Library for FPGA

Block Parameters

Device index

Enter a number between 0 and 7. The maximum number of allowed boards is 8.

Port name

Enter the FPGA output port name.

Port offset

Enter the PCI register offset address for the ports being read.

Valid offset addresses begin at 0x8000. Each PCI address must be unique and 32-bit aligned, such as `hex2dec('8000')`, `hex2dec('8004')`, and so on.

Port type

Enter the data type of the ports being read (`uint32` (fixed)).

Port dimension

Enter the dimension of the ports being read (*number of addresses to read*). If **Port dimension** is greater than 1, you must use a strobe.

Strobe offset

Enter the PCI register offset address for the signal being used to latch data from the FPGA into the ports being read. If **Strobe offset** is 0, the strobe is not used.

Valid offset addresses begin at 0x8000. Each PCI address must be unique and 32-bit aligned, such as `hex2dec('8000')`, `hex2dec('8004')`, and so on.

Sample time

Enter the base sample time or a multiple of the base sample time (-1 means sample time is inherited).

Related Examples

- “FPGA Programming and Configuration”

External Websites

- www.speedgoat.ch

Speedgoat IO312

FPGA board providing 32 bidirectional RS-422 I/O lines

Board

Speedgoat IO312

General Description

The Speedgoat IO312 is a field-programmable gate array (FPGA) board that provides 32 bidirectional RS-422 I/O lines. This board is based on a Xilinx Virtex-II chip with 24192 logic cells. Design tools supporting this chip include the Xilinx ISE Design Suite, version 10.1 (www.xilinx.com).

The default clock rate for this board is 33 MHz.

The Simulink Real-Time block library supports this board with these driver blocks:

- Speedgoat IO312 PCI Setup
- Speedgoat IO312 PCI Read
- Speedgoat IO312 PCI Write

The Speedgoat FPGA I/O board block descriptions are for informational purposes only. The HDL Coder HDL Workflow Advisor uses these blocks to generate a Simulink Real-Time interface subsystem. The subsystem mask controls the block parameters. Do not edit the parameters directly.

The Speedgoat IO312 68 Pin Connector Map lists the I/O channel to connector pin assignments.

Speedgoat IO312 68 Pin Connector Map

Connector Pin	I/O Channel	Direction	Transceiver
1	0(+)	Input/Output	RS-422
2	0(-)		
3	1(+)	Input/Output	RS-422

Connector Pin	I/O Channel	Direction	Transceiver
4	1(-)		
5	2(+)	Input/Output	RS-422
6	2(-)		
7	3(+)	Input/Output	RS-422
8	3(-)		
9	4(+)	Input/Output	RS-422
10	4(-)		
11	5(+)	Input/Output	RS-422
12	5(-)		
13	6(+)	Input/Output	RS-422
14	6(-)		
15	7(+)	Input/Output	RS-422
16	7(-)		
17	Ground		
18	Ground		
19	8(+)	Input/Output	RS-422
20	8(-)		
21	9(+)	Input/Output	RS-422
22	9(-)		
23	10(+)	Input/Output	RS-422
24	10(-)		
25	11(+)	Input/Output	RS-422
26	11(-)		
27	12(+)	Input/Output	RS-422
28	12(-)		
29	13(+)	Input/Output	RS-422
30	13(-)		
31	14(+)	Input/Output	RS-422

Connector Pin	I/O Channel	Direction	Transceiver
32	14(-)		
33	15(+)	Input/Output	RS-422
34	15(-)		
35		Ground	
36		Ground	
37	16(+)	Input/Output	RS-422
38	16(-)		
39	17(+)	Input/Output	RS-422
40	17(-)		
41	18(+)	Input/Output	RS-422
42	18(-)		
43	19(+)	Input/Output	RS-422
44	19(-)		
45	20(+)	Input/Output	RS-422
46	20(-)		
47	21(+)	Input/Output	RS-422
48	21(-)		
49	22(+)	Input/Output	RS-422
50	22(-)		
51	23(+)	Input/Output	RS-422
52	23(-)		
53	24(+)	Input/Output	RS-422
54	24(-)		
55	25(+)	Input/Output	RS-422
56	25(-)		
57	26(+)	Input/Output	RS-422
58	26(-)		
59	27(+)	Input/Output	RS-422

Connector Pin	I/O Channel	Direction	Transceiver
60	27(-)		
61	28(+)	Input/Output	RS-422
62	28(-)		
63	29(+)	Input/Output	RS-422
64	29(-)		
65	30(+)	Input/Output	RS-422
66	30(-)		
67	31(+)	Input/Output	RS-422
68	31(-)		

Board Characteristics

Board name	IO312
Clock rate	24–100 MHz, default 33 MHz
Manufacturer	Speedgoat
Bus type	PCI
Multiple block instance support	Yes
Multiple board support	Yes

Related Examples

- “FPGA Programming and Configuration”

External Websites

- www.speedgoat.ch

Speedgoat IO312 PCI Read

Speedgoat IO312 PCI Read block

Description

The Speedgoat IO312 PCI Read block reads a 32-bit data value from a PCI port offset address. Output is a `uint32` data type.

The Speedgoat FPGA I/O board block descriptions are for informational purposes only. The HDL Coder HDL Workflow Advisor uses these blocks to generate a Simulink Real-Time interface subsystem. The subsystem mask controls the block parameters. Do not edit the parameters directly.

Library

Simulink Real-Time Library for FPGA

Block Parameters

Device index

Enter a number between 0 and 7. The maximum number of allowed boards is 8.

Port name

Enter the FPGA output port name.

Port offset

Enter the PCI register offset address for the ports being read.

Valid offset addresses begin at 0x8000. Each PCI address must be unique and 32-bit aligned, such as `hex2dec('8000')`, `hex2dec('8004')`, and so on.

Port type

Enter the data type of the ports being read (`uint32` (fixed)).

Port dimension

Enter the dimension of the ports being read (*number of addresses to read*). If **Port dimension** is greater than 1, you must use a strobe.

Strobe offset

Enter the PCI register offset address for the signal being used to latch data from the FPGA into the ports being read. If **Strobe offset** is 0, the strobe is not used.

Valid offset addresses begin at 0x8000. Each PCI address must be unique and 32-bit aligned, such as `hex2dec('8000')`, `hex2dec('8004')`, and so on.

Sample time

Enter the base sample time or a multiple of the base sample time (-1 means sample time is inherited).

Related Examples

- “FPGA Programming and Configuration”

External Websites

- www.speedgoat.ch

Speedgoat IO312 PCI Setup

Speedgoat IO312 PCI Setup block

Description

The Speedgoat IO312 PCI Setup block performs the setup and configuration to use the Speedgoat IO312 board.

The Speedgoat FPGA I/O board block descriptions are for informational purposes only. The HDL Coder HDL Workflow Advisor uses these blocks to generate a Simulink Real-Time interface subsystem. The subsystem mask controls the block parameters. Do not edit the parameters directly.

Library

Simulink Real-Time Library for FPGA

Block Parameters

FPGA model/subsystem name

Enter a string to identify the model and subsystem containing the Setup block.

Run FPGA only when Simulink Real-Time runs

Select this check box for the FPGA to execute only when the real-time application is running.

Clear this check box for the FPGA to start immediately after the real-time application is loaded.

Reset FPGA states on start

Select this check box for the FPGA to reset the initial state of the FPGA variables and registers to the default state on startup. Takes effect only when you select the check box **Run FPGA only when Simulink Real-Time runs**.

Clear this check box for the FPGA to retain the end state of the previous execution. To return to the initial state, download the model to the target again and restart the simulation.

The default setting is **Selected**.

Device index

Enter a number between 0 and 7. The maximum number of allowed boards is 8.

PCI slot (-1:autosearch)

If only one board of this type is in the Speedgoat target machine, enter -1 to locate the board.

If two or more boards of this type are in the Speedgoat target machine, enter the bus number and the PCI slot number of the board associated with this driver block. Use the format **[BusNumber,SlotNumber]**.

To determine the bus number and the PCI slot number, type:

```
tg = slrt;  
getPCIInfo(tg, 'installed')
```

Related Examples

- “FPGA Programming and Configuration”

External Websites

- www.speedgoat.ch

Speedgoat IO312 PCI Write

Speedgoat IO312 PCI Write block

Description

The Speedgoat IO312 PCI Write block writes a 32-bit data value to a PCI port offset address. Input must be a `uint32` data type.

The Speedgoat FPGA I/O board block descriptions are for informational purposes only. The HDL Coder HDL Workflow Advisor uses these blocks to generate a Simulink Real-Time interface subsystem. The subsystem mask controls the block parameters. Do not edit the parameters directly.

Library

Simulink Real-Time Library for FPGA

Block Parameters

Device index

Enter a number between 0 and 7. The maximum number of allowed boards is 8.

Port name

Enter the FPGA output port name.

Port offset

Enter the PCI register offset address for the ports being read.

Valid offset addresses begin at 0x8000. Each PCI address must be unique and 32-bit aligned, such as `hex2dec('8000')`, `hex2dec('8004')`, and so on.

Port type

Enter the data type of the ports being read (`uint32` (fixed)).

Port dimension

Enter the dimension of the ports being read (*number of addresses to read*). If **Port dimension** is greater than 1, you must use a strobe.

Strobe offset

Enter the PCI register offset address for the signal being used to latch data from the FPGA into the ports being read. If **Strobe offset** is 0, the strobe is not used.

Valid offset addresses begin at 0x8000. Each PCI address must be unique and 32-bit aligned, such as `hex2dec('8000')`, `hex2dec('8004')`, and so on.

Sample time

Enter the base sample time or a multiple of the base sample time (-1 means sample time is inherited).

Related Examples

- “FPGA Programming and Configuration”

External Websites

- www.speedgoat.ch

Speedgoat IO313

FPGA board providing 16 bidirectional TTL and 24 bidirectional RS-422 I/O lines

Board

Speedgoat IO313

General Description

The Speedgoat IO313 is a field-programmable gate array (FPGA) board that provides 16 bidirectional TTL and 24 bidirectional RS-422 I/O lines. This board is based on a Xilinx Virtex-II chip with 24192 logic cells. Design tools supporting this chip include the Xilinx ISE Design Suite, version 10.1 (www.xilinx.com).

The default clock rate for this board is 33 MHz.

The Simulink Real-Time block library supports this board with these driver blocks:

- Speedgoat IO313 PCI Setup
- Speedgoat IO313 PCI Read
- Speedgoat IO313 PCI Write

The Speedgoat FPGA I/O board block descriptions are for informational purposes only. The HDL Coder HDL Workflow Advisor uses these blocks to generate a Simulink Real-Time interface subsystem. The subsystem mask controls the block parameters. Do not edit the parameters directly.

The Speedgoat IO313 68 Pin Connector Map lists the I/O channel to connector pin assignments.

Speedgoat IO313 68 Pin Connector Map

Connector Pin	I/O Channel	Direction	Transceiver
1	0	Input/Output	TTL
2	1		
3	2	Input/Output	TTL

Connector Pin	I/O Channel	Direction	Transceiver
4	3		
5	4	Input/Output	TTL
6	5		
7	6	Input/Output	TTL
8	7		
9	8	Input/Output	TTL
10	9		
11	10	Input/Output	TTL
12	11		
13	12	Input/Output	TTL
14	13		
15	14	Input/Output	TTL
16	15		
17	Ground		
18	Ground		
19	0(+)	Input/Output	RS-422
20	0(-)		
21	1(+)	Input/Output	RS-422
22	1(-)		
23	2(+)	Input/Output	RS-422
24	2(-)		
25	3(+)	Input/Output	RS-422
26	3(-)		
27	4(+)	Input/Output	RS-422
28	4(-)		
29	5(+)	Input/Output	RS-422
30	5(-)		
31	6(+)	Input/Output	RS-422

Connector Pin	I/O Channel	Direction	Transceiver
32	6(-)		
33	7(+)	Input/Output	RS-422
34	7(-)		
35	Ground		
36	Ground		
37	8(+)	Input/Output	RS-422
38	8(-)		
39	9(+)	Input/Output	RS-422
40	9(-)		
41	10(+)	Input/Output	RS-422
42	10(-)		
43	11(+)	Input/Output	RS-422
44	11(-)		
45	12(+)	Input/Output	RS-422
46	12(-)		
47	13(+)	Input/Output	RS-422
48	13(-)		
49	14(+)	Input/Output	RS-422
50	14(-)		
51	15(+)	Input/Output	RS-422
52	15(-)		
53	16(+)	Input/Output	RS-422
54	16(-)		
55	17(+)	Input/Output	RS-422
56	17(-)		
57	18(+)	Input/Output	RS-422
58	18(-)		
59	19(+)	Input/Output	RS-422

Connector Pin	I/O Channel	Direction	Transceiver
60	19(-)		
61	20(+)	Input/Output	RS-422
62	20(-)		
63	21(+)	Input/Output	RS-422
64	21(-)		
65	22(+)	Input/Output	RS-422
66	22(-)		
67	23(+)	Input/Output	RS-422
68	23(-)		

Board Characteristics

Board name	IO313
Clock rate	24–100 MHz, default 33 MHz
Manufacturer	Speedgoat
Bus type	PCI
Multiple block instance support	Yes
Multiple board support	Yes

Related Examples

- “FPGA Programming and Configuration”

External Websites

- www.speedgoat.ch

Speedgoat IO313 PCI Read

Speedgoat IO313 PCI Read block

Description

The Speedgoat IO313 PCI Read block reads a 32-bit data value from a PCI port offset address. Output is a `uint32` data type.

The Speedgoat FPGA I/O board block descriptions are for informational purposes only. The HDL Coder HDL Workflow Advisor uses these blocks to generate a Simulink Real-Time interface subsystem. The subsystem mask controls the block parameters. Do not edit the parameters directly.

Library

Simulink Real-Time Library for FPGA

Block Parameters

Device index

Enter a number between 0 and 7. The maximum number of allowed boards is 8.

Port name

Enter the FPGA output port name.

Port offset

Enter the PCI register offset address for the ports being read.

Valid offset addresses begin at 0x8000. Each PCI address must be unique and 32-bit aligned, such as `hex2dec('8000')`, `hex2dec('8004')`, and so on.

Port type

Enter the data type of the ports being read (`uint32` (fixed)).

Port dimension

Enter the dimension of the ports being read (*number of addresses to read*). If **Port dimension** is greater than 1, you must use a strobe.

Strobe offset

Enter the PCI register offset address for the signal being used to latch data from the FPGA into the ports being read. If **Strobe offset** is 0, the strobe is not used.

Valid offset addresses begin at 0x8000. Each PCI address must be unique and 32-bit aligned, such as `hex2dec('8000')`, `hex2dec('8004')`, and so on.

Sample time

Enter the base sample time or a multiple of the base sample time (-1 means sample time is inherited).

Related Examples

- “FPGA Programming and Configuration”

External Websites

- www.speedgoat.ch

Speedgoat IO313 PCI Setup

Speedgoat IO313 PCI Setup block

Description

The Speedgoat IO313 PCI Setup block performs the setup and configuration to use the Speedgoat IO313 board.

The Speedgoat FPGA I/O board block descriptions are for informational purposes only. The HDL Coder HDL Workflow Advisor uses these blocks to generate a Simulink Real-Time interface subsystem. The subsystem mask controls the block parameters. Do not edit the parameters directly.

Library

Simulink Real-Time Library for FPGA

Block Parameters

FPGA model/subsystem name

Enter a string to identify the model and subsystem containing the Setup block.

Run FPGA only when Simulink Real-Time runs

Select this check box for the FPGA to execute only when the real-time application is running.

Clear this check box for the FPGA to start immediately after the real-time application is loaded.

Reset FPGA states on start

Select this check box for the FPGA to reset the initial state of the FPGA variables and registers to the default state on startup. Takes effect only when you select the check box **Run FPGA only when Simulink Real-Time runs**.

Clear this check box for the FPGA to retain the end state of the previous execution. To return to the initial state, download the model to the target again and restart the simulation.

The default setting is **Selected**.

Device index

Enter a number between 0 and 7. The maximum number of allowed boards is 8.

PCI slot (-1:autosearch)

If only one board of this type is in the Speedgoat target machine, enter -1 to locate the board.

If two or more boards of this type are in the Speedgoat target machine, enter the bus number and the PCI slot number of the board associated with this driver block. Use the format **[BusNumber,SlotNumber]**.

To determine the bus number and the PCI slot number, type:

```
tg = slrt;  
getPCIInfo(tg, 'installed')
```

Related Examples

- “FPGA Programming and Configuration”

External Websites

- www.speedgoat.ch

Speedgoat IO313 PCI Write

Speedgoat IO313 PCI Write block

Description

The Speedgoat IO313 PCI Write block writes a 32-bit data value to a PCI port offset address. Input must be a `uint32` data type.

The Speedgoat FPGA I/O board block descriptions are for informational purposes only. The HDL Coder HDL Workflow Advisor uses these blocks to generate a Simulink Real-Time interface subsystem. The subsystem mask controls the block parameters. Do not edit the parameters directly.

Library

Simulink Real-Time Library for FPGA

Block Parameters

Device index

Enter a number between 0 and 7. The maximum number of allowed boards is 8.

Port name

Enter the FPGA output port name.

Port offset

Enter the PCI register offset address for the ports being read.

Valid offset addresses begin at 0x8000. Each PCI address must be unique and 32-bit aligned, such as `hex2dec('8000')`, `hex2dec('8004')`, and so on.

Port type

Enter the data type of the ports being read (`uint32` (fixed)).

Port dimension

Enter the dimension of the ports being read (*number of addresses to read*). If **Port dimension** is greater than 1, you must use a strobe.

Strobe offset

Enter the PCI register offset address for the signal being used to latch data from the FPGA into the ports being read. If **Strobe offset** is 0, the strobe is not used.

Valid offset addresses begin at 0x8000. Each PCI address must be unique and 32-bit aligned, such as `hex2dec('8000')`, `hex2dec('8004')`, and so on.

Sample time

Enter the base sample time or a multiple of the base sample time (-1 means sample time is inherited).

Related Examples

- “FPGA Programming and Configuration”

External Websites

- www.speedgoat.ch

Speedgoat IO314

FPGA board providing 32 bidirectional LVDS I/O lines

Board

Speedgoat IO314

General Description

The **Speedgoat IO314** is a field-programmable gate array (FPGA) board that provides 32 bidirectional LVDS I/O lines. This board is based on a Xilinx Virtex-II chip with 24192 logic cells. Design tools supporting this chip include the Xilinx ISE Design Suite, version 10.1 (www.xilinx.com).

The default clock rate for this board is 33 MHz.

The Simulink Real-Time block library supports this board with these driver blocks:

- Speedgoat IO314 PCI Setup
- Speedgoat IO314 PCI Read
- Speedgoat IO314 PCI Write

The Speedgoat FPGA I/O board block descriptions are for informational purposes only. The HDL Coder HDL Workflow Advisor uses these blocks to generate a Simulink Real-Time interface subsystem. The subsystem mask controls the block parameters. Do not edit the parameters directly.

The **Speedgoat IO314** provides up to 32 channels of 2.5 volt LVDS. See **Speedgoat IO314 68 Pin Connector Map (LVDS)** for more information on channel/pin assignment.

Speedgoat IO314 68 Pin Connector Map (LVDS)

Connector Pin	I/O Channel	Direction	Transceiver
1	0(+)	Input/Output	LVDS
35	0(-)		
2	1(+)	Input/Output	LVDS

Connector Pin	I/O Channel	Direction	Transceiver
36	1(-)		
3	2(+)	Input/Output	LVDS
37	2(-)		
4	3(+)	Input/Output	LVDS
38	3(-)		
5	4(+)	Input/Output	LVDS
39	4(-)		
6	5(+)	Input/Output	LVDS
40	5(-)		
7	6(+)	Input/Output	LVDS
41	6(-)		
8	7(+)	Input/Output	LVDS
42	7(-)		
9	8(+)	Input/Output	LVDS
43	8(-)		
10	9(+)	Input/Output	LVDS
44	9(-)		
11	10(+)	Input/Output	LVDS
45	10(-)		
12		Ground	
46		Ground	
13	11(+)	Input/Output	LVDS
47	11(-)		
14	12(+)	Input/Output	LVDS
48	12(-)		
15	13(+)	Input/Output	LVDS
49	13(-)		
16	14(+)	Input/Output	LVDS

Connector Pin	I/O Channel	Direction	Transceiver
50	14(-)		
17	15(+)	Input/Output	LVDS
51	15(-)		
18	16(+)	Input/Output	LVDS
52	16(-)		
19	17(+)	Input/Output	LVDS
53	17(-)		
20	18(+)	Input/Output	LVDS
54	18(-)		
21	19(+)	Input/Output	LVDS
55	19(-)		
22	20(+)	Input/Output	LVDS
56	20(-)		
23		Ground	
57		Ground	
24	21(+)	Input/Output	LVDS
58	21(-)		
25	22(+)	Input/Output	LVDS
59	22(-)		
26	23(+)	Input/Output	LVDS
60	23(-)		
27	24(+)	Input/Output	LVDS
61	24(-)		
28	25(+)	Input/Output	LVDS
62	25(-)		
29	26(+)	Input/Output	LVDS
63	26(-)		
30	27(+)	Input/Output	LVDS

Connector Pin	I/O Channel	Direction	Transceiver
64	27(-)		
31	28(+)	Input/Output	LVDS
65	28(-)		
32	29(+)	Input/Output	LVDS
66	29(-)		
33	30(+)	Input/Output	LVDS
67	30(-)		
34	31(+)	Input/Output	LVDS
68	31(-)		

Board Characteristics

Board name	IO314
Clock rate	24–100 MHz, default 33 MHz
Manufacturer	Speedgoat
Bus type	PCI
Multiple block instance support	Yes
Multiple board support	Yes

Related Examples

- “FPGA Programming and Configuration”

External Websites

- www.speedgoat.ch

Speedgoat IO314 PCI Read

Speedgoat IO314 PCI Read block

Description

The Speedgoat IO314 PCI Read block reads a 32-bit data value from a PCI port offset address. Output is a `uint32` data type.

The Speedgoat FPGA I/O board block descriptions are for informational purposes only. The HDL Coder HDL Workflow Advisor uses these blocks to generate a Simulink Real-Time interface subsystem. The subsystem mask controls the block parameters. Do not edit the parameters directly.

Library

Simulink Real-Time Library for FPGA

Block Parameters

Device index

Enter a number between 0 and 7. The maximum number of allowed boards is 8.

Port name

Enter the FPGA output port name.

Port offset

Enter the PCI register offset address for the ports being read.

Valid offset addresses begin at 0x8000. Each PCI address must be unique and 32-bit aligned, such as `hex2dec('8000')`, `hex2dec('8004')`, and so on.

Port type

Enter the data type of the ports being read (`uint32` (fixed)).

Port dimension

Enter the dimension of the ports being read (*number of addresses to read*). If **Port dimension** is greater than 1, you must use a strobe.

Strobe offset

Enter the PCI register offset address for the signal being used to latch data from the FPGA into the ports being read. If **Strobe offset** is 0, the strobe is not used.

Valid offset addresses begin at 0x8000. Each PCI address must be unique and 32-bit aligned, such as `hex2dec('8000')`, `hex2dec('8004')`, and so on.

Sample time

Enter the base sample time or a multiple of the base sample time (-1 means sample time is inherited).

Related Examples

- “FPGA Programming and Configuration”

External Websites

- www.speedgoat.ch

Speedgoat IO314 PCI Setup

Speedgoat IO314 PCI Setup block

Description

The Speedgoat IO314 PCI Setup block performs the setup and configuration to use the Speedgoat IO314 board.

The Speedgoat FPGA I/O board block descriptions are for informational purposes only. The HDL Coder HDL Workflow Advisor uses these blocks to generate a Simulink Real-Time interface subsystem. The subsystem mask controls the block parameters. Do not edit the parameters directly.

Library

Simulink Real-Time Library for FPGA

Block Parameters

FPGA model/subsystem name

Enter a string to identify the model and subsystem containing the Setup block.

Run FPGA only when Simulink Real-Time runs

Select this check box for the FPGA to execute only when the real-time application is running.

Clear this check box for the FPGA to start immediately after the real-time application is loaded.

Reset FPGA states on start

Select this check box for the FPGA to reset the initial state of the FPGA variables and registers to the default state on startup. Takes effect only when you select the check box **Run FPGA only when Simulink Real-Time runs**.

Clear this check box for the FPGA to retain the end state of the previous execution. To return to the initial state, download the model to the target again and restart the simulation.

The default setting is **Selected**.

Device index

Enter a number between 0 and 7. The maximum number of allowed boards is 8.

PCI slot (-1:autosearch)

If only one board of this type is in the Speedgoat target machine, enter -1 to locate the board.

If two or more boards of this type are in the Speedgoat target machine, enter the bus number and the PCI slot number of the board associated with this driver block. Use the format **[BusNumber,SlotNumber]**.

To determine the bus number and the PCI slot number, type:

```
tg = slrt;  
getPCIInfo(tg, 'installed')
```

Related Examples

- “FPGA Programming and Configuration”

External Websites

- www.speedgoat.ch

Speedgoat IO314 PCI Write

Speedgoat IO314 PCI Write block

Description

The Speedgoat IO314 PCI Write block writes a 32-bit value to a PCI port offset address. Input must be a `uint32` data type.

The Speedgoat FPGA I/O board block descriptions are for informational purposes only. The HDL Coder HDL Workflow Advisor uses these blocks to generate a Simulink Real-Time interface subsystem. The subsystem mask controls the block parameters. Do not edit the parameters directly.

Library

Simulink Real-Time Library for FPGA

Block Parameters

Device index

Enter a number between 0 and 7. The maximum number of allowed boards is 8.

Port name

Enter the FPGA output port name.

Port offset

Enter the PCI register offset address for the ports being read.

Valid offset addresses begin at 0x8000. Each PCI address must be unique and 32-bit aligned, such as `hex2dec('8000')`, `hex2dec('8004')`, and so on.

Port type

Enter the data type of the ports being read (`uint32` (fixed)).

Port dimension

Enter the dimension of the ports being read (*number of addresses to read*). If **Port dimension** is greater than 1, you must use a strobe.

Strobe offset

Enter the PCI register offset address for the signal being used to latch data from the FPGA into the ports being read. If **Strobe offset** is 0, the strobe is not used.

Valid offset addresses begin at 0x8000. Each PCI address must be unique and 32-bit aligned, such as `hex2dec('8000')`, `hex2dec('8004')`, and so on.

Sample time

Enter the base sample time or a multiple of the base sample time (-1 means sample time is inherited).

Related Examples

- “FPGA Programming and Configuration”

External Websites

- www.speedgoat.ch

Speedgoat IO321

FPGA board providing 64 bidirectional LVC MOS or 32 bidirectional LVDS I/O lines (four input only)

Board

Speedgoat IO321

General Description

The Speedgoat IO321 is a field-programmable gate array (FPGA) board that provides 64 bidirectional LVC MOS or 32 bidirectional LVDS I/O lines (four are input only). The Speedgoat IO321-5 also provides two 16-bit 105 MHz analog input channels. This board is based on a Xilinx Virtex-4 chip with 41472 logic cells. Design tools supporting this chip include the Xilinx ISE Design Suite, version 10.1 (www.xilinx.com).

The Speedgoat IO321 is the base board. The Speedgoat IO321-5 is the Speedgoat IO321 plus the AXM-A30 high-speed A/D port subassembly.

The default clock rate for this board is 66 MHz.

The Simulink Real-Time block library supports this board with these driver blocks:

- Speedgoat IO321 PCI Setup
- Speedgoat IO321-5 A/D Calibration
- Speedgoat IO321 PCI Read
- Speedgoat IO321 PCI Write

The Speedgoat FPGA I/O board block descriptions are for informational purposes only. The HDL Coder HDL Workflow Advisor uses these blocks to generate a Simulink Real-Time interface subsystem. The subsystem mask controls the block parameters. Do not edit the parameters directly.

The Speedgoat IO321 provides up to 64 channels of 2.5 volt LVC MOS and up to 32 channels of 2.5 volt LVDS. You can use both LVC MOS and LVDS channels in a single system. However, channel selection must uniquely map to connector pins. For example, you cannot concurrently use the same connector pins for both LVC MOS and LVDS. For

more information, see the Speedgoat IO321 68 Pin Connector Map (LVCMOS) and the Speedgoat IO321 68 Pin Connector Map (LVDS).

The Speedgoat IO321-5 configuration adds two analog input ports to those provided by the Speedgoat IO321. For more information, see “Speedgoat IO321-5 A/D Input Ports” on page 52-78.

When defining...	Use Table
LVCMOS channels	Speedgoat IO321 68 Pin Connector Map (LVCMOS)
LVDS channels	Speedgoat IO321 68 Pin Connector Map (LVDS)

Speedgoat IO321 68 Pin Connector Map (LVCMOS)

Connector Pin	I/O Channel	Direction	Transceiver
1	0	Input/Output	LVCMOS
35	1	Input/Output	LVCMOS
2	2	Input/Output	LVCMOS
36	3	Input/Output	LVCMOS
3	4	Input/Output	LVCMOS
37	5	Input/Output	LVCMOS
4	6	Input/Output	LVCMOS
38	7	Input/Output	LVCMOS
5	8	Input/Output	LVCMOS
39	9	Input/Output	LVCMOS
6	10	Input/Output	LVCMOS
40	11	Input/Output	LVCMOS
7	12	Input/Output	LVCMOS
41	13	Input/Output	LVCMOS
8	14	Input/Output	LVCMOS
42	15	Input/Output	LVCMOS
9	16	Input/Output	LVCMOS
43	17	Input/Output	LVCMOS
10	18	Input/Output	LVCMOS

Connector Pin	I/O Channel	Direction	Transceiver
44	19	Input/Output	LVC MOS
11	20	Input/Output	LVC MOS
45	21	Input/Output	LVC MOS
12	22	Input/Output	LVC MOS
46	23	Input/Output	LVC MOS
13	24	Input/Output	LVC MOS
47	25	Input/Output	LVC MOS
14	26	Input/Output	LVC MOS
48	27	Input/Output	LVC MOS
15	28	Input/Output	LVC MOS
49	29	Input/Output	LVC MOS
16	30	Input/Output	LVC MOS
50	31	Input/Output	LVC MOS
17	32	Input/Output	LVC MOS
51	33	Input/Output	LVC MOS
18	34	Input/Output	LVC MOS
52	35	Input/Output	LVC MOS
19	36	Input/Output	LVC MOS
53	37	Input/Output	LVC MOS
20	38	Input/Output	LVC MOS
54	39	Input/Output	LVC MOS
21	40	Input/Output	LVC MOS
55	41	Input/Output	LVC MOS
22	42	Input/Output	LVC MOS
56	43	Input/Output	LVC MOS
23	44	Input/Output	LVC MOS
57	45	Input/Output	LVC MOS
24	46	Input/Output	LVC MOS

Connector Pin	I/O Channel	Direction	Transceiver
58	47	Input/Output	LVC MOS
25	48	Input/Output	LVC MOS
59	49	Input/Output	LVC MOS
26	50	Input/Output	LVC MOS
60	51	Input/Output	LVC MOS
27	52	Input/Output	LVC MOS
61	53	Input/Output	LVC MOS
28	54	Input/Output	LVC MOS
62	55	Input/Output	LVC MOS
29	56	Input/Output	LVC MOS
63	57	Input/Output	LVC MOS
30	58	Input/Output	LVC MOS
64	59	Input/Output	LVC MOS
31	60	Input/Output	LVC MOS
65	61	Input/Output	LVC MOS
32	62	Input/Output	LVC MOS
66	63	Input/Output	LVC MOS
33	Ground		
67	Ground		
34	Ground		
68	Ground		

Speedgoat IO321 68 Pin Connector Map (LVDS)

Connector Pin	I/O Channel	Direction	Transceiver
1	0(+)	Input	LVDS
35	0(-)		
2	1(+)	Input/Output	LVDS
36	1(-)		

Connector Pin	I/O Channel	Direction	Transceiver
3	2(+)	Input/Output	LVDS
37	2(-)		
4	3(+)	Input/Output	LVDS
38	3(-)		
5	4(+)	Input/Output	LVDS
39	4(-)		
6	5(+)	Input	LVDS
40	5(-)		
7	6(+)	Input/Output	LVDS
41	6(-)		
8	7(+)	Input/Output	LVDS
42	7(-)		
9	8(+)	Input/Output	LVDS
43	8(-)		
10	9(+)	Input/Output	LVDS
44	9(-)		
11	10(+)	Input/Output	LVDS
45	10(-)		
12	11(+)	Input/Output	LVDS
46	11(-)		
13	12(+)	Input/Output	LVDS
47	12(-)		
14	13(+)	Input/Output	LVDS
48	13(-)		
15	14(+)	Input/Output	LVDS
49	14(-)		
16	15(+)	Input	LVDS
50	15(-)		

Connector Pin	I/O Channel	Direction	Transceiver
17	16(+)	Input/Output	LVDS
51	16(-)		
18	17(+)	Input/Output	LVDS
52	17(-)		
19	18(+)	Input/Output	LVDS
53	18(-)		
20	19(+)	Input/Output	LVDS
54	19(-)		
21	20(+)	Input/Output	LVDS
55	20(-)		
22	21(+)	Input/Output	LVDS
56	21(-)		
23	22(+)	Input/Output	LVDS
57	22(-)		
24	23(+)	Input	LVDS
58	23(-)		
25	24(+)	Input/Output	LVDS
59	24(-)		
26	25(+)	Input/Output	LVDS
60	25(-)		
27	26(+)	Input/Output	LVDS
61	26(-)		
28	27(+)	Input/Output	LVDS
62	27(-)		
29	28(+)	Input/Output	LVDS
63	28(-)		
30	29(+)	Input/Output	LVDS
64	29(-)		

Connector Pin	I/O Channel	Direction	Transceiver
31	30(+)	Input/Output	LVDS
65	30(-)		
32	31(+)	Input/Output	LVDS
66	31(-)		
33	Ground		
67	Ground		
34	Ground		
68	Ground		

Board Characteristics

Board name	IO321
Clock rate	32–100 MHz, default 66 MHz
Manufacturer	Speedgoat
Bus type	PCI
Multiple block instance support	Yes
Multiple board support	Yes

Speedgoat IO321-5 A/D Input Ports

The Speedgoat IO321-5 high-speed A/D port subassembly supports two analog input ports that connect to a 16-bit A/D converter. It transmits their measured voltage to the FPGA as signed 16-bit fixed-point integers.

- **+32767** represents +1.6 V
- **0** represents 0 V
- **-32767** represents -1.6 V

Voltages scale linearly.

When you assign an input port to the A/D in HDL Coder HDL Workflow Advisor, the software adds calibration parameters to the interface block. For more information, see “Generate Simulink Real-Time Interface for Speedgoat Boards”.

Calibration Procedure

Calibration requires a precision voltage source. This source must be capable of generating the required calibration voltages into a 50 Ω load to the accuracy and precision that you want.

To calibrate the Speedgoat IO321-5 A/D port assembly for **Ch 1** and **Ch 2**.

- 1 In the subsystem interface block mask, initialize parameter **Gain_{Ch}** to 1.0. For information on the **Gain** and **Offset** data entry format, see Speedgoat IO321-5 A/D Calibration.
- 2 Connect the voltage source to channel **Ch**.
- 3 Apply 0 V to **Ch**. Read the measured value from the A/D several times, recording your measurements. (The measured value is noisy, with a typical uncertainty of ± 30 units.)
- 4 Choose an average value.
- 5 Open the subsystem interface block mask. Into the **Offset** parameter for channel **Ch**, enter the negative of the average value, leaving **Gain_{Ch}** set to 1.0.
- 6 Rebuild your model and check the results.
- 7 If the average value is acceptably close to 0, continue with step 8. Otherwise, repeat steps 1–6 until you have refined **Offset_{Ch}** to the accuracy and precision that you want.
- 8 Choose a calibration voltage. Calculate its expected value depending upon the scaling that you want. For example, if you want 1.6 V to produce 32767 units and the calibration voltage is 1.0 V:

$$1.6 / 32767 = 1.0 / \textit{ExpectedValue}$$

$$\textit{ExpectedValue} = 1.0 / 1.6 * 32767$$

$$\textit{ExpectedValue} = 20479$$

- 9 Apply the calibration voltage (1 V) to the channel. From the A/D, read the measured value. Calculate **Gain_{Ch}** using the following equation:

$$Gain = ExpectedValue / MeasuredValue$$

- 10 Open the subsystem interface block mask. Enter the calculated **Gain_{Ch}** value into the block parameters for channel **Ch**.
- 11 Rebuild your model and check the results.
- 12 Repeat steps 1–11 for the other channel.

During execution, the A/D applies the calibration factors to each channel using the following equation:

$$CalibratedOutput_{Ch} = (MeasuredValue_{Ch} + Offset_{Ch}) * Gain_{Ch}$$

For instance, suppose **Ch 1** calibrates as follows:

Expected Value	Measured Value	Offset	Gain
0 (~0 V)	425	-425	—
20479 (~1 V)	20000	—	1.024

During execution, if the measured value at **Ch 1** is 10000, the calibrated value is:

$$CalibratedOutput_{Ch1} = (10000 + (-425)) * 1.024 = 9805$$

or approximately 0.48 V.

Port Characteristics

Name	AXM-A30
Input configuration	Two differential channels using two Analog Devices [®] AD9460 A/D converters
Manufacturer	Acromag
A/D resolution	16 bits
Input range	3.4 V peak-to-peak, centered at 0V, into 50 Ω load
Operating Temperature	0–70 °C
Signal-to-noise ratio	69 dB (25 °C) typical

Signal-to-noise and distortion	67dB (25 °C) typical
Clock rate	66 MHz (fixed)
Maximum throughput rate (1 and 2 channel)	9.5 nS (105 MHz)
A/D trigger	FPGA controlled
Connectors	Four SMA PCB jack receptacle connectors (non-isolated)

Speedgoat IO321 A/D Input Port Connector Map

SMA Connector	Connector Description
1	Analog Input Ch1
2	External Clock (not used)
3	External Trigger (not used)
4	Analog Input Ch2

Related Examples

- “FPGA Programming and Configuration”

External Websites

- www.speedgoat.ch

Speedgoat IO321-5 A/D Calibration

Speedgoat IO321-5 AXM-A30 Calibration block factors

Description

The Speedgoat IO321-5 A/D Calibration block generates A/D gain and offset corrections for the Speedgoat IO321-5 A/D Input Port Assembly.

The Speedgoat FPGA I/O board block descriptions are for informational purposes only. The HDL Coder HDL Workflow Advisor uses these blocks to generate a Simulink Real-Time interface subsystem. The subsystem mask controls the block parameters. Do not edit the parameters directly.

Library

Simulink Real-Time Library for FPGA

Block Parameters

Device index

Enter a number between 0 and 7. The maximum number of allowed boards is 8.

A/D Gain Corrections in the range [0:1.999]

Enter pairs of the form **[Ch1Gain,Ch2Gain]**. **Ch1Gain** is the gain correction (**double**) for channel 1. **Ch2Gain** is the gain correction (**double**) for channel 2.

A/D Offset Corrections

Enter pairs of the form **[Ch10ffset,Ch20ffset]**. **Ch10ffset** is the offset correction (**int16**) for channel 1. **Ch20ffset** is the offset correction (**int16**) for channel 2.

For more information on how to calculate these factors, see “Speedgoat IO321-5 A/D Input Ports” on page 52-78.

Related Examples

- “FPGA Programming and Configuration”

External Websites

- www.speedgoat.ch

Speedgoat IO321 PCI Read

Speedgoat IO321 PCI Read block

Description

The Speedgoat IO321 PCI Read block reads a 32-bit data value from a PCI port offset address. Output is a `uint32` data type.

The Speedgoat FPGA I/O board block descriptions are for informational purposes only. The HDL Coder HDL Workflow Advisor uses these blocks to generate a Simulink Real-Time interface subsystem. The subsystem mask controls the block parameters. Do not edit the parameters directly.

Library

Simulink Real-Time Library for FPGA

Block Parameters

Device index

Enter a number between 0 and 7. The maximum number of allowed boards is 8.

Port name

Enter the FPGA output port name.

Port offset

Enter the PCI register offset address for the ports being read.

Valid offset addresses begin at 0x8000. Each PCI address must be unique and 32-bit aligned, such as `hex2dec('8000')`, `hex2dec('8004')`, and so on.

Port type

Enter the data type of the ports being read (`uint32` (fixed)).

Port dimension

Enter the dimension of the ports being read (*number of addresses to read*). If **Port dimension** is greater than 1, you must use a strobe.

Strobe offset

Enter the PCI register offset address for the signal being used to latch data from the FPGA into the ports being read. If **Strobe offset** is 0, the strobe is not used.

Valid offset addresses begin at 0x8000. Each PCI address must be unique and 32-bit aligned, such as `hex2dec('8000')`, `hex2dec('8004')`, and so on.

Sample time

Enter the base sample time or a multiple of the base sample time (-1 means sample time is inherited).

Related Examples

- “FPGA Programming and Configuration”

External Websites

- www.speedgoat.ch

Speedgoat IO321 PCI Setup

Speedgoat IO321 PCI Setup block

Description

The Speedgoat IO321 PCI Setup block performs the setup and configuration to use the Speedgoat IO321 board.

The Speedgoat FPGA I/O board block descriptions are for informational purposes only. The HDL Coder HDL Workflow Advisor uses these blocks to generate a Simulink Real-Time interface subsystem. The subsystem mask controls the block parameters. Do not edit the parameters directly.

Library

Simulink Real-Time Library for FPGA

Block Parameters

FPGA model/subsystem name

Enter a string to identify the model and subsystem containing the Setup block.

Run FPGA only when Simulink Real-Time runs

Select this check box for the FPGA to execute only when the real-time application is running.

Clear this check box for the FPGA to start immediately after the real-time application is loaded.

Reset FPGA states on start

Select this check box for the FPGA to reset the initial state of the FPGA variables and registers to the default state on startup. Takes effect only when you select the check box **Run FPGA only when Simulink Real-Time runs**.

Clear this check box for the FPGA to retain the end state of the previous execution. To return to the initial state, download the model to the target again and restart the simulation.

The default setting is **Selected**.

Device index

Enter a number between 0 and 7. The maximum number of allowed boards is 8.

PCI slot (-1:autosearch)

If only one board of this type is in the Speedgoat target machine, enter -1 to locate the board.

If two or more boards of this type are in the Speedgoat target machine, enter the bus number and the PCI slot number of the board associated with this driver block. Use the format **[BusNumber,SlotNumber]**.

To determine the bus number and the PCI slot number, type:

```
tg = slrt;  
getPCIInfo(tg, 'installed')
```

Related Examples

- “FPGA Programming and Configuration”

External Websites

- www.speedgoat.ch

Speedgoat IO321 PCI Write

Speedgoat IO321 PCI Write block

Description

The Speedgoat IO321 PCI Write block writes a 32-bit value to a PCI port offset address. Input must be a `uint32` data type.

The Speedgoat FPGA I/O board block descriptions are for informational purposes only. The HDL Coder HDL Workflow Advisor uses these blocks to generate a Simulink Real-Time interface subsystem. The subsystem mask controls the block parameters. Do not edit the parameters directly.

Library

Simulink Real-Time Library for FPGA

Block Parameters

Device index

Enter a number between 0 and 7. The maximum number of allowed boards is 8.

Port name

Enter the FPGA output port name.

Port offset

Enter the PCI register offset address for the ports being read.

Valid offset addresses begin at 0x8000. Each PCI address must be unique and 32-bit aligned, such as `hex2dec('8000')`, `hex2dec('8004')`, and so on.

Port type

Enter the data type of the ports being read (`uint32 (fixed)`).

Port dimension

Enter the dimension of the ports being read (*number of addresses to read*). If **Port dimension** is greater than 1, you must use a strobe.

Strobe offset

Enter the PCI register offset address for the signal being used to latch data from the FPGA into the ports being read. If **Strobe offset** is 0, the strobe is not used.

Valid offset addresses begin at 0x8000. Each PCI address must be unique and 32-bit aligned, such as `hex2dec('8000')`, `hex2dec('8004')`, and so on.

Sample time

Enter the base sample time or a multiple of the base sample time (-1 means sample time is inherited).

Related Examples

- “FPGA Programming and Configuration”

External Websites

- www.speedgoat.ch

Speedgoat IO331

FPGA board providing 64 bidirectional LVC MOS or 32 bidirectional LVDS I/O lines

Board

Speedgoat IO331

General Description

The Speedgoat IO331 is a field-programmable gate array (FPGA) board that provides 64 bidirectional LVC MOS or 32 bidirectional LVDS I/O lines. This board is based on a Xilinx Spartan® 6 chip with 147333 logic cells. Design tools supporting this chip include the Xilinx ISE Design Suite, version 14.7 (www.xilinx.com).

The Speedgoat IO331 is the base board. The Speedgoat IO331-6 is the AXM-A75 A/D converter, an add-on to the Speedgoat IO331.

The default clock rate for this board is 75 MHz. When you use the AXM-A75 A/D or D/A interfaces, the clock rate cannot exceed 75 MHz.

The Simulink Real-Time block library supports this board with these driver blocks:

- Speedgoat IO3xx PCI Setup
- Speedgoat IO3xx PCI Read
- Speedgoat IO3xx PCI Write
- Speedgoat IO3xx PCI Read/Write
- Speedgoat IO331-6 A/D Range

The Speedgoat FPGA I/O board block descriptions are for informational purposes only. The HDL Coder HDL Workflow Advisor uses these blocks to generate a Simulink Real-Time interface subsystem. The subsystem mask controls the block parameters. Do not edit the parameters directly.

The Speedgoat IO331 provides up to 64 channels of 2.5 volt LVC MOS and up to 32 channels of 2.5 volt LVDS. You can use both LVC MOS and LVDS channels in a single system. However, channel selection must uniquely map to connector pins. For example,

you cannot concurrently use the same connector pins for both LVCMOS and LVDS. For more information on channel/pin assignment, see the following tables.

The Speedgoat IO331-6 configuration adds 16 differential analog input channels, 8 analog output channels, and 16 digital I/O channels to those provided by the Speedgoat IO331. For more information, see “Speedgoat IO331-6 A/D and D/A Converter” on page 52-96.

When defining...	Use Table
LVCMOS channels	Speedgoat IO331 68 Pin Connector Map (LVCMOS)
LVDS channels	Speedgoat IO331 68 Pin Connector Map (LVDS)

Speedgoat IO331 68 Pin Connector Map (LVCMOS)

Connector Pin	I/O Channel	Direction	Transceiver
1	0	Input/Output	LVCMOS
2	1	Input/Output	LVCMOS
35	2	Input/Output	LVCMOS
36	3	Input/Output	LVCMOS
3	4	Input/Output	LVCMOS
4	5	Input/Output	LVCMOS
37	6	Input/Output	LVCMOS
38	7	Input/Output	LVCMOS
5	8	Input/Output	LVCMOS
6	9	Input/Output	LVCMOS
39	10	Input/Output	LVCMOS
40	11	Input/Output	LVCMOS
7	12	Input/Output	LVCMOS
8	13	Input/Output	LVCMOS
41	14	Input/Output	LVCMOS
42	15	Input/Output	LVCMOS
9	16	Input/Output	LVCMOS
10	17	Input/Output	LVCMOS

Connector Pin	I/O Channel	Direction	Transceiver
43	18	Input/Output	LVC MOS
44	19	Input/Output	LVC MOS
11	20	Input/Output	LVC MOS
12	21	Input/Output	LVC MOS
45	22	Input/Output	LVC MOS
46	23	Input/Output	LVC MOS
13	24	Input/Output	LVC MOS
14	25	Input/Output	LVC MOS
47	26	Input/Output	LVC MOS
48	27	Input/Output	LVC MOS
15	28	Input/Output	LVC MOS
16	29	Input/Output	LVC MOS
49	30	Input/Output	LVC MOS
50	31	Input/Output	LVC MOS
17	32	Input/Output	LVC MOS
18	33	Input/Output	LVC MOS
51	34	Input/Output	LVC MOS
52	35	Input/Output	LVC MOS
19	36	Input/Output	LVC MOS
20	37	Input/Output	LVC MOS
53	38	Input/Output	LVC MOS
54	39	Input/Output	LVC MOS
21	40	Input/Output	LVC MOS
22	41	Input/Output	LVC MOS
55	42	Input/Output	LVC MOS
56	43	Input/Output	LVC MOS
23	44	Input/Output	LVC MOS
24	45	Input/Output	LVC MOS

Connector Pin	I/O Channel	Direction	Transceiver
57	46	Input/Output	LVC MOS
58	47	Input/Output	LVC MOS
25	48	Input/Output	LVC MOS
26	49	Input/Output	LVC MOS
59	50	Input/Output	LVC MOS
60	51	Input/Output	LVC MOS
27	52	Input/Output	LVC MOS
28	53	Input/Output	LVC MOS
61	54	Input/Output	LVC MOS
62	55	Input/Output	LVC MOS
29	56	Input/Output	LVC MOS
30	57	Input/Output	LVC MOS
63	58	Input/Output	LVC MOS
64	59	Input/Output	LVC MOS
31	60	Input/Output	LVC MOS
32	61	Input/Output	LVC MOS
65	62	Input/Output	LVC MOS
66	63	Input/Output	LVC MOS
33	Ground		
34	Ground		
67	Ground		
68	Ground		

Speedgoat IO331 68 Pin Connector Map (LVDS)

Connector Pin	I/O Channel	Direction	Transceiver
1	0(+)	Input/Output	LVDS
2	0(-)		
35	1(+)	Input/Output	LVDS

Connector Pin	I/O Channel	Direction	Transceiver
36	1(-)		
3	2(+)	Input/Output	LVDS
4	2(-)		
37	3(+)	Input/Output	LVDS
38	3(-)		
5	4(+)	Input/Output	LVDS
6	4(-)		
39	5(+)	Input/Output	LVDS
40	5(-)		
7	6(+)	Input/Output	LVDS
8	6(-)		
41	7(+)	Input/Output	LVDS
42	7(-)		
9	8(+)	Input/Output	LVDS
10	8(-)		
43	9(+)	Input/Output	LVDS
44	9(-)		
11	10(+)	Input/Output	LVDS
12	10(-)		
45	11(+)	Input/Output	LVDS
46	11(-)		
13	12(+)	Input/Output	LVDS
14	12(-)		
47	13(+)	Input/Output	LVDS
48	13(-)		
15	14(+)	Input/Output	LVDS
16	14(-)		
49	15(+)	Input/Output	LVDS

Connector Pin	I/O Channel	Direction	Transceiver
50	15(-)		
17	16(+)	Input/Output	LVDS
18	16(-)		
51	17(+)	Input/Output	LVDS
52	17(-)		
19	18(+)	Input/Output	LVDS
20	18(-)		
53	19(+)	Input/Output	LVDS
54	19(-)		
21	20(+)	Input/Output	LVDS
22	20(-)		
55	21(+)	Input/Output	LVDS
56	21(-)		
23	22(+)	Input/Output	LVDS
24	22(-)		
57	23(+)	Input/Output	LVDS
58	23(-)		
25	24(+)	Input/Output	LVDS
26	24(-)		
59	25(+)	Input/Output	LVDS
60	25(-)		
27	26(+)	Input/Output	LVDS
28	26(-)		
61	27(+)	Input/Output	LVDS
62	27(-)		
29	28(+)	Input/Output	LVDS
30	28(-)		
63	29(+)	Input/Output	LVDS

Connector Pin	I/O Channel	Direction	Transceiver
64	29(-)		
31	30(+)	Input/Output	LVDS
32	30(-)		
65	31(+)	Input/Output	LVDS
66	31(-)		
33		Ground	
34		Ground	
67		Ground	
68		Ground	

Board Characteristics

Board name	IO331
Clock rate	10–125 MHz, default 75 MHz
Manufacturer	Speedgoat
Bus type	PCI
Multiple block instance support	Yes
Multiple board support	Yes

Speedgoat IO331-6 A/D and D/A Converter

The Speedgoat IO331-6 A/D converter supports 16 differential analog input channels. It transmits their measured voltage to the FPGA as signed 16-bit fixed-point integers. The IO331-6 D/A converter supports 8 analog output channels and receives their voltage setting from the FPGA as signed 16-bit fixed-point integers.

For both input and output channels:

- +32767 represents the positive end of the input range
- 0 represents 0 V

- -32767 represents the negative end of the input range

When the board is running at its maximum clock rate of 75 MHz, the A/D sampling rate is approximately 500 kHz. As the board clock rate drops to 10 MHz, the sampling rate decreases linearly to 200 kHz.

The D/A sampling rate is approximately 100 kHz.

When you use the A/D or D/A interfaces, the IO331-6 clock rate cannot exceed 75 MHz.

Port Characteristics

Name	AXM-A75
Manufacturer	Acromag
Analog input configuration	16 differential channels using 16 Analog Devices AD7686 A/D converters
Input range	± 10.24 , ± 5.12 , ± 2.56 , ± 1.28 V
A/D resolution	16 bits
Maximum A/D trigger rate	500 kHz
Analog output configuration	8 channels using 8 Analog Devices AD5764RB D/A converters
Output range	± 10 , ± 10.2564 , ± 10.5263 V
D/A resolution	16 bits
D/A trigger rate (fixed)	100 kHz
Digital I/O	16 TTL channels
Operating temperature	0–70 °C
Maximum clock rate	75 MHz
Connectors	68-pin VHDCI receptacle

In the J1 connector map, the pin names are adapted from the manufacturer's data sheet. The pin names, which are zero-based, map to the names used in HDL Coder HDL Workflow Advisor as follows:

- VIN — A/D Input Channel
- VOUT — D/A Output Channel
- DIO — TTL I/O (AXM-A75) Channel [0:15]

Each digital I/O pin can be configured as either input or output, but not as both at the same time.

Speedgoat IO331-6 A/D Converter 68-Pin J1 Connector Map

Pin Description	Number	Pin Description	Number
GND	1	DIO0	35
DIO1	2	DIO2	36
DIO3	3	DIO4	37
DIO5	4	DIO6	38
DIO7	5	GND	39
DIO8	6	DIO9	40
DIO10	7	DIO11	41
DIO12	8	DIO13	42
DIO14	9	DIO15	43
GND	10	VOUT0	44
GND	11	VOUT1	45
GND	12	VOUT2	46
GND	13	VOUT3	47
GND	14	VOUT4	48
GND	15	VOUT5	49
GND	16	VOUT6	50
GND	17	VOUT7	51
GND	18	GND	52
VIN15-	19	VIN15+	53
VIN14-	20	VIN14+	54
VIN13-	21	VIN13+	55
VIN12-	22	VIN12+	56
VIN11-	23	VIN11+	57
VIN10-	24	VIN10+	58

Pin Description	Number	Pin Description	Number
VIN9-	25	VIN9+	59
VIN8-	26	VIN8+	60
VIN7-	27	VIN7+	61
VIN6-	28	VIN6+	62
VIN5-	29	VIN5+	63
VIN4-	30	VIN4+	64
VIN3-	31	VIN3+	65
VIN2-	32	VIN2+	66
VIN1-	33	VIN1+	67
VIN0-	34	VIN0+	68

Related Examples

- “FPGA Programming and Configuration”

External Websites

- www.speedgoat.ch

Speedgoat IO3xx PCI Setup

Speedgoat IO3xx PCI Setup block

Description

The **Speedgoat IO3xx PCI Setup** block performs the setup and configuration to use the Speedgoat IO3xx boards.

The Speedgoat FPGA I/O board block descriptions are for informational purposes only. The HDL Coder HDL Workflow Advisor uses these blocks to generate a Simulink Real-Time interface subsystem. The subsystem mask controls the block parameters. Do not edit the parameters directly.

Library

Simulink Real-Time Library for FPGA

Block Parameters

FPGA model/subsystem name

Enter a string to identify the model and subsystem containing the **Setup** block.

FPGA board type

Select the type of FPGA being set up. You can use this block for all of the Speedgoat IO3xx FPGA I/O boards.

Run FPGA only when Simulink Real-Time runs

Select this check box for the FPGA to execute only when the real-time application is running.

Clear this check box for the FPGA to start immediately after the real-time application is loaded.

Reset FPGA states on start

Select this check box for the FPGA to reset the initial state of the FPGA variables and registers to the default state on startup. Takes effect only when you select the check box **Run FPGA only when Simulink Real-Time runs**.

Clear this check box for the FPGA to retain the end state of the previous execution. To return to the initial state, download the model to the target again and restart the simulation.

The default setting is **Selected**.

Device index

Enter a number between 0 and 7. The maximum number of allowed boards is 8.

PCI slot (-1:autosearch)

If only one board of this type is in the Speedgoat target machine, enter -1 to locate the board.

If two or more boards of this type are in the Speedgoat target machine, enter the bus number and the PCI slot number of the board associated with this driver block. Use the format **[BusNumber, SlotNumber]**.

To determine the bus number and the PCI slot number, type:

```
tg = slrt;  
getPCIInfo(tg, 'installed')
```

Related Examples

- “FPGA Programming and Configuration”

External Websites

- www.speedgoat.ch

Speedgoat IO3xx PCI Read

Speedgoat IO3xx PCI Read block

Description

The Speedgoat IO3xx PCI Read block reads a 32-bit data value from a PCI port offset address. Output is a `uint32` data type.

The Speedgoat FPGA I/O board block descriptions are for informational purposes only. The HDL Coder HDL Workflow Advisor uses these blocks to generate a Simulink Real-Time interface subsystem. The subsystem mask controls the block parameters. Do not edit the parameters directly.

Library

Simulink Real-Time Library for FPGA

Block Parameters

Device index

Enter a number between 0 and 7. The maximum number of allowed boards is 8.

Port name

Enter the FPGA output port name.

Port offset

Enter the PCI register offset address for the ports being read.

Valid offset addresses begin at 0x8000. Each PCI address must be unique and 32-bit aligned, such as `hex2dec('8000')`, `hex2dec('8004')`, and so on.

Port type

Enter the data type of the ports being read (`uint32` (fixed)).

Port dimension

Enter the dimension of the ports being read (*number of addresses to read*). If **Port dimension** is greater than 1, you must use a strobe.

Strobe offset

Enter the PCI register offset address for the signal being used to latch data from the FPGA into the ports being read. If **Strobe offset** is 0, the strobe is not used.

Valid offset addresses begin at 0x8000. Each PCI address must be unique and 32-bit aligned, such as `hex2dec('8000')`, `hex2dec('8004')`, and so on.

Sample time

Enter the base sample time or a multiple of the base sample time (-1 means sample time is inherited).

Related Examples

- “FPGA Programming and Configuration”

External Websites

- www.speedgoat.ch

Speedgoat IO3xx PCI Write

Speedgoat IO3xx PCI Write block

Description

The Speedgoat IO3xx PCI Write block writes a 32-bit data value to a PCI port offset address. Input must be a `uint32` data type.

The Speedgoat FPGA I/O board block descriptions are for informational purposes only. The HDL Coder HDL Workflow Advisor uses these blocks to generate a Simulink Real-Time interface subsystem. The subsystem mask controls the block parameters. Do not edit the parameters directly.

Library

Simulink Real-Time Library for FPGA

Block Parameters

Device index

Enter a number between 0 and 7. The maximum number of allowed boards is 8.

Port name

Enter the FPGA output port name.

Port offset

Enter the PCI register offset address for the ports being read.

Valid offset addresses begin at 0x8000. Each PCI address must be unique and 32-bit aligned, such as `hex2dec('8000')`, `hex2dec('8004')`, and so on.

Port type

Enter the data type of the ports being read (`uint32` (fixed)).

Port dimension

Enter the dimension of the ports being read (*number of addresses to read*). If **Port dimension** is greater than 1, you must use a strobe.

Strobe offset

Enter the PCI register offset address for the signal being used to latch data from the FPGA into the ports being read. If **Strobe offset** is 0, the strobe is not used.

Valid offset addresses begin at 0x8000. Each PCI address must be unique and 32-bit aligned, such as `hex2dec('8000')`, `hex2dec('8004')`, and so on.

Sample time

Enter the base sample time or a multiple of the base sample time (-1 means sample time is inherited).

Related Examples

- “FPGA Programming and Configuration”

External Websites

- www.speedgoat.ch

Speedgoat IO3xx PCI Read/Write

Speedgoat IO3xx PCI Read/Write block

Description

The Speedgoat IO3xx PCI Read/Write block reads one or more 32-bit data values from a PCI port offset address. The block output is of data type `uint32`. The Read/Write block writes one or more 32-bit data values to a PCI port offset address. The block input must be of data type `uint32`.

The block supports three synchronization modes:

- Free running
- Coprocessing – blocking
- Coprocessing – nonblocking with delay

For more information about these modes, see “FPGA Synchronization Modes”.

The Speedgoat FPGA I/O board block descriptions are for informational purposes only. The HDL Coder HDL Workflow Advisor uses these blocks to generate a Simulink Real-Time interface subsystem. The subsystem mask controls the block parameters. Do not edit the parameters directly.

Library

Simulink Real-Time Library for FPGA

Block Parameters

Device index

Enter a number between 0 and 7. The maximum number of allowed boards is 8.

Operating mode

Select one of the following:

- **Free running (default)** — Nonsynchronized. The CPU and the FPGA each run continuously and in parallel. When using the FPGA as an I/O module, select this mode.
- **Coprocessing – blocking** — Synchronized. When the FPGA execution time is short compared to the Speedgoat target machine sample time, select this coprocessor mode.
- **Coprocessing – nonblocking with delay** — Synchronized. When the FPGA execution time is long compared to the Speedgoat target machine sample time, select this coprocessor mode.

Non-streaming write offset

Enter the PCI register offset address for the ports being written with non-streaming data.

Valid offset addresses begin at 0x8000. Each PCI address must be unique and 32-bit aligned, such as `hex2dec('8000')`, `hex2dec('8004')`, and so on.

Non-streaming write types

Enter a cell array containing the data type of each port being written with non-streaming data `uint32` (fixed). For example, enter `{'uint32'}`.

Non-streaming write lengths

Enter a cell array containing the number of vector elements in the port being written with non-streaming data. For example, enter `[1]`.

If the sum of the values in **Non-streaming write lengths** is greater than 1, you must set **Write strobe offset** to a nonzero value. For example, both `[5]` and `[1 1]` require a strobe.

Streaming write offset

For internal use only.

Streaming write types

For internal use only.

Streaming write length

For internal use only.

Write strobe offset

Enter the PCI register offset address for the signal being used to latch data into the FPGA from the ports being written. If **Write strobe offset** is 0, the strobe is not used.

Valid offset addresses begin at 0x8000. Each PCI address must be unique and 32-bit aligned, such as `hex2dec('8000')`, `hex2dec('8004')`, and so on.

Non-streaming read offset

Enter the PCI register offset address for the ports being read as non-streaming data.

Valid offset addresses begin at 0x8000. Each PCI address must be unique and 32-bit aligned, such as `hex2dec('8000')`, `hex2dec('8004')`, and so on.

Non-streaming read types

Enter a cell array containing the data type of each port being read as non-streaming data `uint32` (fixed). For example, enter `{'uint32'}`.

Non-streaming read lengths

Enter a cell array containing the number of vector elements in the port being read as non-streaming data. For example, enter `[1]`.

If the sum of the values in **Non-streaming read lengths** is greater than 1, you must set **Read strobe offset** to a nonzero value. For example, both `[5]` and `[1 1]` require a strobe.

Streaming read offset

For internal use only.

Streaming read types

For internal use only.

Streaming read length

For internal use only.

Read strobe offset

Enter the PCI register offset address for the signal being used to latch data into the FPGA from the ports being read. If **Read strobe offset** is 0, the strobe is not used.

Valid offset addresses begin at 0x8000. Each PCI address must be unique and 32-bit aligned, such as `hex2dec('8000')`, `hex2dec('8004')`, and so on.

Sample time

Enter the base sample time or a multiple of the base sample time (-1 means sample time is inherited).

Related Examples

- “FPGA Programming and Configuration”

External Websites

- www.speedgoat.ch

Speedgoat IO331-6 A/D Range

Speedgoat IO331-6 AXM-A75 A/D range setup block

Description

The Speedgoat IO331-6 A/D Range block specifies the voltage range for the Speedgoat IO331-6 A/D converter.

The Speedgoat FPGA I/O board block descriptions are for informational purposes only. The HDL Coder HDL Workflow Advisor uses these blocks to generate a Simulink Real-Time interface subsystem. The subsystem mask controls the block parameters. Do not edit the parameters directly.

Library

Simulink Real-Time Library for FPGA

Block Parameters

Device index

Enter a number between 0 and 7. The maximum number of allowed boards is 8.

Range

Select the voltage range for the analog input. Legal values are:

- ± 10.24 volts
- ± 5.12 volts
- ± 2.56 volts
- ± 1.28 volts

Related Examples

- “FPGA Programming and Configuration”

External Websites

- www.speedgoat.ch

UEI, Versallogic, Asynchronous Events

United Electronic Industries (UEI)

This topic describes how to use the UEI groups of boards supported by the Simulink Real-Time product (www.ueidaq.com).

A/D Frame Acquisition

In A/D frame acquisition, also called hardware-timed acquisition, the board acquires a set of data points equally spaced in time. This set of data points is called a frame. To process a frame, the hardware raises an interrupt, which triggers the model to process the frame. Because the board acquires the entire frame before raising the interrupt, the frame does not have data gaps at the boundaries.

You can model high-throughput environmental sensors and audio processing using A/D frame blocks.

Specifying UEI Boards

The United Electronic Industries (UEI) PowerDAQ board series contains a large number of boards. The board names follow a standard pattern:

[Form Factor]-[Board Type]-[Channel]-[Speed]/[Resolution][Gain]

For example, one UEI board is named PD2-MF-16-1M/12L. The possibilities for the parts of the name are

- **Form Factor** — The form factor can be one of two things. PD2 denotes a 32-bit, 33 MHz PCI bus board. PDXI indicates a 32-bit, 33 MHz PXI/PCI bus board.
- **Board Type** — The board type can be one of three things. MF indicates a multifunction board. MFS indicates a multifunction board with sample and hold. AO indicates an analog output board.
- **Channel** — For MF and MFS board types, the channel is the number of analog input channels. For AO board types, the channel is the number of analog output channels.
- **Speed** — The speed is the number of samples per second supported by the board.
- **Resolution** — For MF and MFS boards, the Resolution is the analog input resolution. For AO board types, the Resolution is the analog output resolution.
- **Gain** — Gain is denoted by letters that represent ranges. DG indicates a gain of 1, 2, 5, or 10. L indicates a range of 1, 10, 100, or 1000. H indicates a range of 1, 2, 4, or 8.

For example, the PD2-MF-16-1M/12L is a PCI multifunction board with sixteen 12-bit analog input channels supporting one million (1M) samples per second with available gains of 1, 10, 100, or 1000.

Changing the Board Associated with the Block

Note that the board displayed on the block is the current board type. To specify a different board, double-click on the block. In the **Board Type** list, choose a different board.

Getting Information on a Specific Board

The boards in this manual are grouped by Form Factor, Board Type, and Resolution. For more information on a specific board, open the MATLAB Help browser. Click on the **Search** tab. Verify that the **Product Filter** is set to **All** or that the Simulink Real-Time

product is one of your selected products. In the **Search type** list, choose **Full Text**. In the **Search for** text box, type the name of your board. Click **Go**. Browse through the search results for more information on your board.

Analog Input Frame Driver Blocks

In this section...

- “Introduction” on page 53-5
- “Notes on Master and Slave Boards” on page 53-5
- “Interrupt Numbers” on page 53-6
- “IRQ Source Block” on page 53-8
- “Example Models” on page 53-8

Introduction

The following UEI PowerDAQ board series have Analog Input frame driver blocks:

- PD2-MF — 12, 14, and 16-bit series
- PD2-MFS — 12, 14, and 16-bit series
- PDXI-MF — 12, 14, and 16-bit series
- PDXI-MFS — 12, 14, and 16-bit series

In frame-based mode, the boards for these driver blocks send interrupts to the Simulink Real-Time software. The Simulink Real-Time model is executed when each frame completes on the board. To use the UEI frame driver blocks, note the IRQ values for each UEI board in the model and configure those boards with the model Configuration Parameters dialog box.

Note: To use the UEI PowerDAQ board series with the Simulink Real-Time Analog Input frame driver blocks, you need to upgrade the UEI PowerDAQ boards. Contact your UEI representative and request the Simulink Real-Time upgrade for these boards.

Notes on Master and Slave Boards

Before you begin, observe the following usage notes for the UEI boards in a master/slave configuration:

- You should set the slowest board as the master. If you do not want to use the slowest board as the master, you can explicitly set the **Acquisition frequency**

parameter of the master board driver block to one that enables the slowest board in the configuration to work. You can derive the maximum speed of the board from the board name.

- Slave boards do not need to be identical to the master board.
- In the model, set the priority of slave blocks higher than master blocks. Right-click the slave or master block and select **Properties**. In the dialog, enter a value in the **Priority** property. For example, if you have multiple slave blocks, you can enter values of 2 for the slave blocks and 3 for the master block, where a lower number indicates a higher priority.
- The number of channels in use on the master does not need to be the same as those used on the slave boards.
- Connect the master and its slave(s) with the J6 connectors on the boards and cables. This connects the acquisition clock and scan clock from the master board to the slave boards.
- The number of slaves you can have is limited by the number of connection points available on the cable and the availability of PCI slots.

Interrupt Numbers

This topic describes how you determine the interrupt number to which the board is set. The methods vary depending on your target computer configuration.

This topic includes

- “Single UEI Board” on page 53-7 — How to use `SimulinkRealTime.target.getPCIInfo` to get information about the PCI devices installed on the target computer. This method works if you have one UEI board in your system. The target computer BIOS assigns the IRQ number.
- “Guidelines for Multiple UEI Boards” on page 53-7 — How to get information about the PCI devices if you have two or more UEI boards configured in a master/slave configuration. This is an iterative method that requires you to restart the target computer with the insertion of each UEI board.

Note: To allow the PCI BIOS to set up the plugged-in PCI cards, disable (set to **NO**) the Plug-and-Play (PnP) operating system feature. The Simulink Real-Time kernel is not a PnP operating system; you must disable this feature or PCI devices will not work on the Simulink Real-Time software.

Single UEI Board

If you have one UEI board for your target computer, that board is the master.

- 1 Insert the UEI board in a slot of your target computer.
- 2 Reboot the target computer.
- 3 On the development computer, open the model that you want to use with the UEI board.
- 4 In the **Simulink > Model Configuration Parameters** dialog box, expand node **Code Generation** and select the **Simulink Real-Time Options** node.
- 5 In the **Real-time interrupt source** parameter, select **Auto (PCI only)**.
- 6 From the **I/O board generating the interrupt** list, select the value **UEI -MFx**. This specifies that the UEI MFx board generates the interrupt.
- 7 For the **PCI slot (-1: autosearch)** parameter, enter the same PCI address as for the UEI MFx Frame block **PCI slot** parameter. Enter -1 (for autodetection) if this is the only UEI board in the target system.
- 8 Click **OK** and save the model.

Guidelines for Multiple UEI Boards

If you have two or more UEI boards in a master/slave configuration, use the following procedure. Note which UEI board you want to use as the master.

- 1 Insert a board into the target computer.
- 2 Reboot the target computer.
- 3 On the development computer, open the model that you want to use with the multiple UEI boards.
- 4 In the **Simulink > Model Configuration Parameters** dialog box, expand node **Code Generation** and select the **Simulink Real-Time Options** node.
- 5 In the **Real-time interrupt source** parameter, select **Auto (PCI only)**.
- 6 From the **I/O board generating the interrupt** list, select the value **UEI -MFx**. This specifies that the UEI MFx board generates the interrupt.
- 7 From a MATLAB Command Window running on the development computer, type

```
tg = slrt;
getPCIInfo(tg, 'all')
```
- 8 Note the slot numbers for the UEI boards.

- 9 Determine the slot number for the master board.
- 10 For the **PCI slot (-1: autosearch)** parameter, enter the bus and the slot number of the master board. Use the format [bus, slot].
- 11 Click **OK** and save the model.

IRQ Source Block

If the UEI A/D frame block is in a Function-Call Subsystem called from an IRQ Source block,

- 1 In the model, select the IRQ Source block.
- 2 From the **IRQ line number** list, select **Auto (PCI only)**.
- 3 From the **I/O board generating the interrupt** list, select the value **UEI -MFx**. This specifies that a UEI MFx board generates the interrupt.
- 4 For the **PCI slot (-1: autosearch)** parameter, enter the same PCI address as for the UEI MFx Frame block **PCI slot (-1: autosearch)** parameter.
 - Only enter -1 (for autodetection) if this is the only UEI board in the target system.
 - If more than one UEI board is or will be in the target system, enter the bus and slot number using the format [bus, slot].
- 5 Click **OK**.
- 6 Repeat this procedure for each IRQ Source block calling separate subsystems.

Example Models

Example models that illustrate the use of UEI frame driver blocks are in the `xpcdemos` folder. To operate these models requires you to set the required interrupt source in the simulation parameters dialog box.

Note that these examples use the UEI PD2-MF-16-333/16H driver block. Replace the block as required by your model.

- `xpcUEIFrame` — A simple frame-based model that outputs to a Simulink Real-Time scope. The model runs each time the board completes a frame of data.
- `xpcUEIMasterSlaveframe` — A master/slave frame-based model.

- `xpcUEIasync` — A model that implements a UEI A/D frame block in a Function-Call Subsystem called by an IRQ Source block. To set the interrupt for the UEI board, you work with the IRQ Source block parameters.

In this example, the interval at which the IRQ Source block triggers the Function-Call Subsystem is the board frame completion time. The rest of the model runs at the model sample time. This latter point implies that there may or may not be a new frame of output data in the output signal when the rest of the model executes. However, if you process the data in the Function-Call Subsystem, this is not an issue.

Note: Even if the frame time at which the board runs is set to the same time as the model sample time, the times will drift relative to each other because the times derive from different sources.

- `xpcUEIDualasync` — A model that implements multiple UEI A/D frame blocks in Function-Call Subsystems called by IRQ Source blocks. To set the interrupt for the UEI boards, you work with the IRQ Source block parameters.
- `xpcFrameLoop` — A model that illustrates how to perform sample-based processing on a frame of data. Because the fastest interrupt available is the frame completion interrupt, the model cannot execute at a faster rate than frame completion. The For Iterator block executes once per frame completion and loops through the data.

United Electronic Industries (UEI): Boards and Blocks

This topic describes the UEI groups of boards supported by the Simulink Real-Time product (www.ueidaq.com).

UEI PD2-MF 12-Bit Series

UEI PD2-MF 12-Bit Series Analog Input (A/D)

UEI PD2-MF 12-Bit Series Frame Analog Input

UEI PD2-MF 12-Bit Series Analog Output (D/A)

UEI PD2-MF 12-Bit Series Digital Input

UEI PD2-MF 12-Bit Series Digital Output

UEI PD2-MF 14-Bit Series

UEI PD2-MF 14-Bit Series Analog Input (A/D)

UEI PD2-MF 14-Bit Series Frame Analog Input

UEI PD2-MF 14-Bit Series Analog Output (D/A)

UEI PD2-MF 14-Bit Series Digital Input

UEI PD2-MF 14-Bit Series Digital Output

UEI PD2-MF 16-Bit Series

UEI PD2-MF 16-Bit Series Analog Input (A/D)

UEI PD2-MF 16-Bit Series Frame Analog Input

UEI PD2-MF 16-Bit Series Analog Output (D/A)

UEI PD2-MF 16-Bit Series Digital Input

UEI PD2-MF 16-Bit Series Digital Output

UEI PD2-MFS 12-Bit Series

UEI PD2-MFS 12-Bit Series Analog Input (A/D)

UEI PD2-MFS 12-Bit Series Frame Analog Input

UEI PD2-MFS 12-Bit Series Analog Output (D/A)

UEI PD2-MFS 12-Bit Series Digital Input

UEI PD2-MFS 12-Bit Series Digital Output

UEI PD2-MFS 14-Bit Series

UEI PD2-MFS 14-Bit Series Analog Input (A/D)

UEI PD2-MFS 14-Bit Series Frame Analog Input

UEI PD2-MFS 14-Bit Series Analog Output (D/A)
UEI PD2-MFS 14-Bit Series Digital Input
UEI PD2-MFS 14-Bit Series Digital Output
UEI PD2-MFS 16-Bit Series
UEI PD2-MFS 16-Bit Series Analog Input (A/D)
UEI PD2-MFS 16-Bit Series Frame Analog Input
UEI PD2-MFS 16-Bit Series Analog Output (D/A)
UEI PD2-MFS 16-Bit Series Digital Input
UEI PD2-MFS 16-Bit Series Digital Output
UEI PDXI-MF 12-Bit Series
UEI PDXI-MF 12-Bit Series Analog Input (A/D)
UEI PDXI-MF 12-Bit Series Frame Analog Input
UEI PDXI-MF 12-Bit Series Analog Output (D/A)
UEI PDXI-MF 12-Bit Series Digital Input
UEI PDXI-MF 12-Bit Series Digital Output
UEI PDXI-MF 14-Bit Series
UEI PDXI-MF 14-Bit Series Analog Input (A/D)
UEI PDXI-MF 14-Bit Series Frame Analog Input
UEI PDXI-MF 14-Bit Series Analog Output (D/A)
UEI PDXI-MF 14-Bit Series Digital Input
UEI PDXI-MF 14-Bit Series Digital Output
UEI PDXI-MF 16-Bit Series
UEI PDXI-MF 16-Bit Series Analog Input (A/D)
UEI PDXI-MF 16-Bit Series Frame Analog Input
UEI PDXI-MF 16-Bit Series Analog Output (D/A)
UEI PDXI-MF 16-Bit Series Digital Input
UEI PDXI-MF 16-Bit Series Digital Output
UEI PDXI-MFS 12-Bit Series
UEI PDXI-MFS 12-Bit Series Analog Input (A/D)
UEI PDXI-MFS 12-Bit Series Frame Analog Input
UEI PDXI-MFS 12-Bit Series Analog Output (D/A)
UEI PDXI-MFS 12-Bit Series Digital Input
UEI PDXI-MFS 12-Bit Series Digital Output
UEI PDXI-MFS 14-Bit Series
UEI PDXI-MFS 14-Bit Series Analog Input (A/D)
UEI PDXI-MFS 14-Bit Series Frame Analog Input
UEI PDXI-MFS 14-Bit Series Analog Output (D/A)
UEI PDXI-MFS 14-Bit Series Digital Input
UEI PDXI-MFS 14-Bit Series Digital Output
UEI PDXI-MFS 16-Bit Series

UEI PDXI-MFS 16-Bit Series Analog Input (A/D)
UEI PDXI-MFS 16-Bit Series Frame Analog Input
UEI PDXI-MFS 16-Bit Series Analog Output (D/A)
UEI PDXI-MFS 16-Bit Series Digital Input
UEI PDXI-MFS 16-Bit Series Digital Output
UEI PD2-AO Series
UEI PD2-AO Analog Output (D/A)
UEI PD2-AO Digital Input
UEI PD2-AO Digital Output
UEI PD2-DIO-64
UEI PD2-DIO-64 Digital Input
UEI PD2-DIO-64 Digital Output
UEI PD2-DIO-128
UEI PD2-DIO-128 Digital Input
UEI PD2-DIO-128 Digital Output
UEI PD2-DIO-128i
UEI PD2-DIO-128i Digital Input
UEI PD2-DIO-128i Digital Output
UEI PDL-DIO-64
UEI PDL-DIO-64 Digital Input
UEI PDL-DIO-64 Digital Output
UEI PDXI-DIO-64
UEI PDXI-DIO-64 Digital Input
UEI PDXI-DIO-64 Digital Output
UEI PDXI-AO Series
UEI PDXI-AO Analog Output (D/A)
UEI PDXI-AO Digital Input
UEI PDXI-AO Digital Output

UEI PD2-MF 12-Bit Series

Support for the UEI PD2-MF 12-Bit Series I/O boards

Board Series

UEI PD2-MF 12-Bit Series

General Board Series Description

The PD2-MF 12-bit series contains I/O boards with 16 or 64 single or 8 or 32 differential analog input (A/D) channels (12-bit) with a maximum sample rate of 1.25 MHz or 3 MHz. The gain varies from 1 to 8 or 1 to 1000. The boards also have 2 analog output (D/A) channels (12-bit), 16 digital input, and 16 digital output lines. The Simulink Real-Time software does not support the counter/timers on these boards.

The Simulink Real-Time block library supports this series of boards with these driver blocks:

- UEI PD2-MF 12-Bit Series Analog Input (A/D)
- UEI PD2-MF 12-Bit Series Frame Analog Input
- UEI PD2-MF 12-Bit Series Analog Output (D/A)
- UEI PD2-MF 12-Bit Series Digital Input
- UEI PD2-MF 12-Bit Series Digital Output

Board Characteristics

Board type	PD2-MF-16-1M/12L
	PD2-MF-16-1M/12H
	PD2-MF-64-1M/12L
	PD2-MF-64-1M/12H
	PD2-MF-16-3M/12L
	PD2-MF-16-3M/12H
	PD2-MF-64-3M/12L
	PD2-MF-64-3M/12H

Manufacturer	United Electronic Industries (UEI)
Bus type	PCI
Access method	Memory mapped
Multiple block instance support	No
Multiple board support	Yes

More About

- “Specifying UEI Boards” on page 53-3

External Websites

- www.ueidaq.com

UEI PD2-MF 12-Bit Series Analog Input (A/D)

PD2-MF 12-Bit Series Analog Input block

Library

Simulink Real-Time Library for UEI

Scaling Input to Output

I/O Module Input	Block Output Data Type	Scaling
Volts	Double	1

Block Parameters

Board type

Select the specific board type from the list provided.

Channel vector

Enter a vector of numbers to specify the input channels. For example, use the first and third analog input (A/D) channels, enter

[1 3]

The channel numbers can occur in arbitrary order. Number the channels beginning with 1 even if this board manufacturer numbers them beginning with 0. The maximum allowable channel number is 4, 8, 16, or 64 depending on the board type.

Gain vector

Enter a vector of numbers to select the gains for each of the channels. Available gains vary depending on board type. MF PGL gains may be set to 1, 10, 100, or 1000. MF PGH gains may be set to 1, 2, 4, or 8. MF DG-option gains may be set to 1, 2, 5, or 10.

Mux settling time vector (slow bit)

This vector must be the same length as the channel vector. It contains values of 0 or 1. If 1, the corresponding channel has a longer settling time. This is useful when using a high gain such as 100 or 1000.

Range

Select the voltage range from the list provided. This applies to all channels.

Input coupling mode

From the list, select one from the following list of input coupling modes:

- Single Ended
- Differential

Refer to the UEI PowerDAQ documentation for input connections.

Sample time

Enter the base sample time or a multiple of the base sample time (- 1 means sample time is inherited).

PCI slot (-1:autosearch)

If only one board of this type is in the target computer, enter - 1 to locate the board.

If two or more boards of this type are in the target computer, enter the bus number and the PCI slot number of the board associated with this driver block. Use the format [**BusNumber,SlotNumber**].

To determine the bus number and the PCI slot number, type:

```
tg = slrt;  
getPCIInfo(tg, 'installed')
```

More About

- “Specifying UEI Boards” on page 53-3

External Websites

- www.ueidaq.com

UEI PD2-MF 12-Bit Series Frame Analog Input

PD2-MF 12-Bit Series Frame Analog Input block

Library

Simulink Real-Time Library for UEI

Scaling Input to Output

I/O Module Input	Block Output Data Type	Scaling
Volts	Double	1

Block Parameters

Board type

Select the specific board type from the list provided.

Channel vector

Enter a vector of numbers that make up one scan. For example, to read the first and fifth channels, enter

```
[1 5]
```

The channel numbers can occur in arbitrary order. Number the channels beginning with 1 even if this board manufacturer numbers them beginning with 0. The maximum allowable channel number is 4, 8, 16, or 64 depending on the board type.

Gain vector

Enter a vector of numbers to specify the gains for each of the channels in the scan. Enter a single value to replicate the gain value across the channels in the scan. Available gains vary depending on board type. Allowable values depend on the board type.

- L (Low level) boards — Specify the gain as one of 1, 10, 100, or 1000.
- H (High level) boards — Specify the gain as one of 1, 2, 4, or 8.
- DG-option boards — Specify the gain as one of 1, 2, 5, or 10.

Mux settling time vector (slow bit)

Enter a vector that is the same length as the channel vector. Each vector element must be a 0 or 1. If you specify 1, the corresponding channel has a longer settling time. To get a more accurate reading, you might want to specify a 1 for channels that have higher gains, such as 100 or 1000. Refer to the UEI PowerDAQ documentation for further information on the longer settling time. This time depends on the board type.

Caution With frame based acquisition, the additional time resulting from setting the **Mux settling time vector (slow bit)** might cause an acquisition overrun that the Simulink Real-Time software does not detect. For example, on a PD2-MF-xx-333/16H board, each acquisition takes 3 microseconds if the slow bit is 0. If the slow bit is 1, that same acquisition takes more than 10 microseconds. With the Simulink Real-Time software, the scan is performed at the maximum rate for a given board. This means that the slow acquisition takes a multiple of 3 microsecond ticks. For a PD2-MF-xx-333/16H board, this becomes 12 microseconds.

For example, assume that N scans of the channel vector compose a frame of data. Assume also that you have a PD2-MF-xx-333/16H board with a **Channel vector** value of [1 2 3 4] and a **Mux settling time vector (slow bit)** value of [0 1 0 1]. For the PD2-MF-xx-333/16H board, two of the acquisition delays are 3 microseconds, and two are 12 microseconds. With a **Frame time** value of 0.001 second, if N is greater than 38, the data will not be acceptable. If you set the slow bits to 0, N can have a value of up to 83. The software detects the limit at $N = 83$, but is not aware of the extra board dependent delay.

Range

From the list, select one of the following voltage ranges. The value you select applies to all channels.

- +-10 Volts
- +-5 Volts
- 0-10 Volts
- 0-5 Volts

Input coupling mode

From the list, select one from the following list of input coupling modes:

- Single Ended
- Differential

Refer to the UEI PowerDAQ documentation for input connections.

Frame size

Enter the number of samples per channel to return as a frame of data. Due to physical constraints in the I/O module, the total number of samples in a frame of data cannot exceed 512. The relationship between the number of samples, frame size, and number of channels is

$$\text{total number of samples} = \text{FrameSize} \times \text{nChannels}$$

For example, if you specify two channels, the frame size must be less than or equal to 256.

Output format

From the list, select either **Frame** or **Vector**.

- **Frame** — Select **Frame** if you expect the output signal from this block to be the input signal for a block that requires a frame. For example, a **Signal Processing** block.
- **Vector** — Select **Vector** if you expect the output signal from this block to be the input signal for a **Simulink Real-Time scope** or some other block that requires vector input.

Scan clock source

Select **Internal** or **External** to identify the clock source for the frame scans.

Scan time

Enter the time (in seconds) between scans as the interval.

Frame time

Enter the interval (in seconds) during which the board will interrupt. The driver block evenly spaces the scans in the frame across the **Frame time** interval. If the **Frame time** interval is too short, you will receive a buffer overrun error at run time. For optimal results, experimentally increase the **Frame time** value and reiterate the process. Rebuild the model when you change this value.

The **Frame size**, **Scan time**, and **Frame time** parameters are not independent, but are related by

$$\text{Frametime} = \text{Framesize} \times \text{Scantime}.$$

After you specify two of the parameters, specify -1 for the third parameter and the equation determines the third parameter.

Note: Because the Simulink Real-Time software uses this value to set parameters on the board, you cannot change the **Frame time** value at the MATLAB prompt.

Block is in an ISR

Select this check box if the block is in an interrupt service routine (ISR). Selecting this check box forces the block sample time to -1 , which enables the block to work in the ISR. If this check box is not selected, the block sample time is equal to the value of **Frame time**.

Slave board

If you have multiple boards configured in a master/slave combination, select this box for the slave boards only. Leave the box unchecked for the master board. (Note that a single board configuration is considered a master board.)

Note: In the model, set the priority of slave blocks higher than master blocks. Right-click the slave or master block and select **Properties**. In the dialog, enter a value in the **Priority** property. For example, if you have multiple slave blocks, you can enter values of 2 for the slave blocks and 3 for the master block, where a lower number indicates a higher priority.

Acquisition frequency

Enter the rate at which the high speed conversion clock runs. This is the clock used to acquire each scan in a frame. For example, with a PD2-MF-xx-333/16H board, the maximum clock is 333 kHz. At that rate, the second channel in a scan will be acquired 3 microseconds after the first one in every scan of the frame.

Specify -1 to select the maximum rate available for the specified board.

DMA burst size

From the list, select either 32, 16, or 8. The DMA engine transfers data in packets of the burst size or less. Between each burst, a new bus arbitration cycle must complete. Better performance is achieved with higher **DMA burst size** values, with 32 being

highest. However, in some architectures and with some PCI bus adaptors, a **DMA burst size** of 32 might cause problems. For example, it might lock up the target computer when DMA is attempted. In these cases, reduce the **DMA burst size** value to 8, rebuild and rerun the real-time application. If the DMA works at 8, select 16 and try again.

PCI slot (-1:autosearch)

If only one board of this type is in the target computer, enter - 1 to locate the board.

If two or more boards of this type are in the target computer, enter the bus number and the PCI slot number of the board associated with this driver block. Use the format **[BusNumber,SlotNumber]**.

To determine the bus number and the PCI slot number, type:

```
tg = slrt;  
getPCIInfo(tg, 'installed')
```

More About

- “Specifying UEI Boards” on page 53-3

External Websites

- www.ueidaq.com

UEI PD2-MF 12-Bit Series Analog Output (D/A)

PD2-MF 12-Bit Series Analog Output block

Library

Simulink Real-Time Library for UEI

Scaling Input to Output

I/O Module Output	Block Input Data Type	Scaling
Volts	Double	1

Block Parameters

Board type

Select the specific board type from the list provided.

Channel vector

Enter a vector of numbers to specify the output channels 1 or 2. For example, to use the first and second analog output (D/A) channels, enter

```
[1 2]
```

The channel numbers can occur in arbitrary order. Number the channels beginning with 1 even if this board manufacturer numbers them beginning with 0.

Reset vector

The reset vector must be the same length as the channel vector. It contains values of 0 or 1. This parameter controls the behavior at model termination. A value of 1 causes the corresponding channel to be reset to the value specified in the initial value vector. A value of 0 causes the channel to remain at the last value attained while the model was running.

Initial value vector

The initial value vector must be the same length as the channel vector and should contain the initial voltage values for the output channels. The channels are set to these values between the time the model is downloaded and the time it is started.

Sample time

Enter the base sample time or a multiple of the base sample time (- 1 means sample time is inherited).

PCI slot (-1:autosearch)

If only one board of this type is in the target computer, enter - 1 to locate the board.

If two or more boards of this type are in the target computer, enter the bus number and the PCI slot number of the board associated with this driver block. Use the format **[BusNumber,SlotNumber]**.

To determine the bus number and the PCI slot number, type:

```
tg = slrt;  
getPCIInfo(tg, 'installed')
```

More About

- “Specifying UEI Boards” on page 53-3

External Websites

- www.ueidaq.com

UEI PD2-MF 12-Bit Series Digital Input

PD2-MF 12-Bit Series Digital Input block

Library

Simulink Real-Time Library for UEI

Scaling Input to Output

I/O Module Input	Block Output Data Type	Scaling
TTL	Double	TTL low = 0.0 TTL high = 1.0

Block Parameters

Board type

Select the specific board type from the list provided.

Channel vector

Enter a vector of numbers to specify the input channels. For example, to use the first and third digital input channels, enter

```
[1 3]
```

The channel numbers can occur in arbitrary order. Number the channels beginning with 1 even if this board manufacturer numbers them beginning with 0. The maximum allowable channel number is 16 except for the PD2-AO and PDXI-AO series. For those boards, the maximum channel number is 8.

Sample time

Enter the base sample time or a multiple of the base sample time (-1 means sample time is inherited).

PCI slot (-1:autosearch)

If only one board of this type is in the target computer, enter -1 to locate the board.

If two or more boards of this type are in the target computer, enter the bus number and the PCI slot number of the board associated with this driver block. Use the format **[BusNumber,SlotNumber]**.

To determine the bus number and the PCI slot number, type:

```
tg = slrt;  
getPCIInfo(tg, 'installed')
```

More About

- “Specifying UEI Boards” on page 53-3

External Websites

- www.ueidaq.com

UEI PD2-MF 12-Bit Series Digital Output

PD2-MF 12-Bit Series Digital Output block

Library

Simulink Real-Time Library for UEI

Scaling Input to Output

I/O Module Output	Block Input Data Type	Scaling
TTL	Double	< 0.5 = TTL low > 0.5 = TTL high

Block Parameters

Board type

Select the specific board type from the list provided.

Channel vector

Enter a vector of numbers to specify the output channels. For example, to use the first and third digital output channels, enter

```
[1 3]
```

The channel numbers can occur in arbitrary order. Number the channels beginning with 1 even if this board manufacturer numbers them beginning with 0. The maximum allowable channel number is 16, except for the PD2-AO and PDXI-AO series. For those boards, the maximum channel number is 8.

Reset vector

The reset vector must be the same length as the channel vector. It contains values of 0 or 1. This parameter controls the behavior at model termination. A value of 1 causes the corresponding channel to be reset to the value specified in the initial value vector. A value of 0 causes the channel to remain at the last value attained while the model was running.

Initial value vector

The initial value vector must be the same length as the channel vector. It contains the initial values (0 or 1) for the output channels. The channels are set to these values between the time the model is downloaded and the time it is started.

Sample time

Enter the base sample time or a multiple of the base sample time (- 1 means sample time is inherited).

PCI slot (-1:autosearch)

If only one board of this type is in the target computer, enter - 1 to locate the board.

If two or more boards of this type are in the target computer, enter the bus number and the PCI slot number of the board associated with this driver block. Use the format [**BusNumber,SlotNumber**].

To determine the bus number and the PCI slot number, type:

```
tg = slrt;  
getPCIInfo(tg, 'installed')
```

More About

- “Specifying UEI Boards” on page 53-3

External Websites

- www.ueidaq.com

UEI PD2-MF 14-Bit Series

Support for the UEI PD2-MF 14-Bit Series I/O boards

Board Series

UEI PD2-MF 14-Bit Series

General Board Series Description

The PD2-MF 14-bit series contains I/O boards with 16 or 64 single or 8 or 32 differential analog input (A/D) channels (14-bit). The gain varies from 1 to 8 or 1 to 1000. The boards also have 2 analog output (D/A) channels (12-bit), 16 digital input lines, and 16 digital output lines. The Simulink Real-Time software does not support the counter/timers on these boards.

The Simulink Real-Time block library supports this series of boards with these driver blocks:

- UEI PD2-MF 14-Bit Series Analog Input (A/D)
- UEI PD2-MF 14-Bit Series Frame Analog Input
- UEI PD2-MF 14-Bit Series Analog Output (D/A)
- UEI PD2-MF 14-Bit Series Digital Input
- UEI PD2-MF 14-Bit Series Digital Output

Board Characteristics

Board type	PD2-MF-16-400/14L PD2-MF-16-400/14H PD2-MF-64-400/14L PD2-MF-64-400/14H PD2-MF-16-2M/14H PD2-MF-64-2M/14H
Manufacturer	United Electronic Industries (UEI)

Bus type	PCI
Access method	Memory mapped
Multiple block instance support	No
Multiple board support	Yes

More About

- “Specifying UEI Boards” on page 53-3

External Websites

- www.ueidaq.com

UEI PD2-MF 14-Bit Series Analog Input (A/D)

PD2-MF 14-Bit Series Analog Input block

Library

Simulink Real-Time Library for UEI

Scaling Input to Output

I/O Module Input	Block Output Data Type	Scaling
Volts	Double	1

Block Parameters

Board type

Select the specific board type from the list provided.

Channel vector

Enter a vector of numbers to specify the input channels. For example, use the first and third analog input (A/D) channels, enter

```
[1 3]
```

The channel numbers can occur in arbitrary order. Number the channels beginning with 1 even if this board manufacturer numbers them beginning with 0. The maximum allowable channel number is 4, 8, 16, or 64 depending on the board type.

Gain vector

Enter a vector of numbers to select the gains for each of the channels. Available gains vary depending on board type. MF PGL gains may be set to 1, 10, 100, or 1000. MF PGH gains may be set to 1, 2, 4, or 8. MF DG-option gains may be set to 1, 2, 5, or 10.

Mux settling time vector (slow bit)

This vector must be the same length as the channel vector. It contains values of 0 or 1. If 1, the corresponding channel has a longer settling time. This is useful when using a high gain such as 100 or 1000.

Range

Select the voltage range from the list provided. This applies to all channels.

Input coupling mode

From the list, select one from the following list of input coupling modes:

- Single Ended
- Differential

Refer to the UEI PowerDAQ documentation for input connections.

Sample time

Enter the base sample time or a multiple of the base sample time (- 1 means sample time is inherited).

PCI slot (-1:autosearch)

If only one board of this type is in the target computer, enter - 1 to locate the board.

If two or more boards of this type are in the target computer, enter the bus number and the PCI slot number of the board associated with this driver block. Use the format [**BusNumber,SlotNumber**].

To determine the bus number and the PCI slot number, type:

```
tg = slrt;  
getPCIInfo(tg, 'installed')
```

More About

- “Specifying UEI Boards” on page 53-3

External Websites

- www.ueidaq.com

UEI PD2-MF 14-Bit Series Frame Analog Input

PD2-MF 14-Bit Series Frame Analog Input block

Library

Simulink Real-Time Library for UEI

Scaling Input to Output

I/O Module Input	Block Output Data Type	Scaling
Volts	Double	1

Block Parameters

Board type

Select the specific board type from the list provided.

Channel vector

Enter a vector of numbers that make up one scan. For example, to read the first and fifth channels, enter

```
[1 5]
```

The channel numbers can occur in arbitrary order. Number the channels beginning with 1 even if this board manufacturer numbers them beginning with 0. The maximum allowable channel number is 4, 8, 16, or 64 depending on the board type.

Gain vector

Enter a vector of numbers to specify the gains for each of the channels in the scan.

Enter a single value to replicate the gain value across the channels in the scan.

Available gains vary depending on board type. Allowable values depend on the board type.

- L (Low level) boards — Specify the gain as one of 1, 10, 100, or 1000.
- H (High level) boards — Specify the gain as one of 1, 2, 4, or 8.
- DG-option boards — Specify the gain as one of 1, 2, 5, or 10.

Mux settling time vector (slow bit)

Enter a vector that is the same length as the channel vector. Each vector element must be a 0 or 1. If you specify 1, the corresponding channel has a longer settling time. To get a more accurate reading, you might want to specify a 1 for channels that have higher gains, such as 100 or 1000. Refer to the UEI PowerDAQ documentation for further information on the longer settling time. This time depends on the board type.

Caution With frame based acquisition, the additional time resulting from setting the **Mux settling time vector (slow bit)** might cause an acquisition overrun that the Simulink Real-Time software does not detect. For example, on a PD2-MF-xx-333/16H board, each acquisition takes 3 microseconds if the slow bit is 0. If the slow bit is 1, that same acquisition takes more than 10 microseconds. With the Simulink Real-Time software, the scan is performed at the maximum rate for a given board. This means that the slow acquisition takes a multiple of 3 microsecond ticks. For a PD2-MF-xx-333/16H board, this becomes 12 microseconds.

For example, assume that N scans of the channel vector compose a frame of data. Assume also that you have a PD2-MF-xx-333/16H board with a **Channel vector** value of [1 2 3 4] and a **Mux settling time vector (slow bit)** value of [0 1 0 1]. For the PD2-MF-xx-333/16H board, two of the acquisition delays are 3 microseconds, and two are 12 microseconds. With a **Frame time** value of 0.001 second, if N is greater than 38, the data will not be acceptable. If you set the slow bits to 0, N can have a value of up to 83. The software detects the limit at $N = 83$, but is not aware of the extra board dependent delay.

Range

From the list, select one of the following voltage ranges. The value you select applies to all channels.

- +-10 Volts
- +-5 Volts
- 0-10 Volts
- 0-5 Volts

Input coupling mode

From the list, select one from the following list of input coupling modes:

- Single Ended
- Differential

Refer to the UEI PowerDAQ documentation for input connections.

Frame size

Enter the number of samples per channel to return as a frame of data. Due to physical constraints in the I/O module, the total number of samples in a frame of data cannot exceed 512. The relationship between the number of samples, frame size, and number of channels is

$$\text{total number of samples} = \text{FrameSize} \times \text{nChannels}$$

For example, if you specify two channels, the frame size must be less than or equal to 256.

Output format

From the list, select either **Frame** or **Vector**.

- **Frame** — Select **Frame** if you expect the output signal from this block to be the input signal for a block that requires a frame. For example, a Signal Processing block.
- **Vector** — Select **Vector** if you expect the output signal from this block to be the input signal for a Simulink Real-Time scope or some other block that requires vector input.

Scan clock source

Select **Internal** or **External** to identify the clock source for the frame scans.

Scan time

Enter the time (in seconds) between scans as the interval.

Frame time

Enter the interval (in seconds) during which the board will interrupt. The driver block evenly spaces the scans in the frame across the **Frame time** interval. If the **Frame time** interval is too short, you will receive a buffer overrun error at run time. For optimal results, experimentally increase the **Frame time** value and reiterate the process. Rebuild the model when you change this value.

The **Frame size**, **Scan time**, and **Frame time** parameters are not independent, but are related by

$$\text{Frametime} = \text{Framesize} \times \text{Scantime}.$$

After you specify two of the parameters, specify -1 for the third parameter and the equation determines the third parameter.

Note: Because the Simulink Real-Time software uses this value to set parameters on the board, you cannot change the **Frame time** value at the MATLAB prompt.

Block is in an ISR

Select this check box if the block is in an interrupt service routine (ISR). Selecting this check box forces the block sample time to -1, which enables the block to work in the ISR. If this check box is not selected, the block sample time is equal to the value of **Frame time**.

Slave board

If you have multiple boards configured in a master/slave combination, select this box for the slave boards only. Leave the box unchecked for the master board. (Note that a single board configuration is considered a master board.)

Note: In the model, set the priority of slave blocks higher than master blocks. Right-click the slave or master block and select **Properties**. In the dialog, enter a value in the **Priority** property. For example, if you have multiple slave blocks, you can enter values of 2 for the slave blocks and 3 for the master block, where a lower number indicates a higher priority.

Acquisition frequency

Enter the rate at which the high speed conversion clock runs. This is the clock used to acquire each scan in a frame. For example, with a PD2-MF-xx-333/16H board, the maximum clock is 333 kHz. At that rate, the second channel in a scan will be acquired 3 microseconds after the first one in every scan of the frame.

Specify -1 to select the maximum rate available for the specified board.

DMA burst size

From the list, select either 32, 16, or 8. The DMA engine transfers data in packets of the burst size or less. Between each burst, a new bus arbitration cycle must complete. Better performance is achieved with higher **DMA burst size** values, with 32 being

highest. However, in some architectures and with some PCI bus adaptors, a **DMA burst size** of 32 might cause problems. For example, it might lock up the target computer when DMA is attempted. In these cases, reduce the **DMA burst size** value to 8, rebuild and rerun the real-time application. If the DMA works at 8, select 16 and try again.

PCI slot (-1:autosearch)

If only one board of this type is in the target computer, enter - 1 to locate the board.

If two or more boards of this type are in the target computer, enter the bus number and the PCI slot number of the board associated with this driver block. Use the format **[BusNumber,SlotNumber]**.

To determine the bus number and the PCI slot number, type:

```
tg = slrt;  
getPCIInfo(tg, 'installed')
```

More About

- “Specifying UEI Boards” on page 53-3

External Websites

- www.ueidaq.com

UEI PD2-MF 14-Bit Series Analog Output (D/A)

PD2-MF 14-Bit Series Analog Output block

Library

Simulink Real-Time Library for UEI

Scaling Input to Output

I/O Module Output	Block Input Data Type	Scaling
Volts	Double	1

Block Parameters

Board type

Select the specific board type from the list provided.

Channel vector

Enter a vector of numbers to specify the output channels 1 or 2. For example, to use the first and second analog output (D/A) channels, enter

```
[1 2]
```

The channel numbers can occur in arbitrary order. Number the channels beginning with 1 even if this board manufacturer numbers them beginning with 0.

Reset vector

The reset vector must be the same length as the channel vector. It contains values of 0 or 1. This parameter controls the behavior at model termination. A value of 1 causes the corresponding channel to be reset to the value specified in the initial value vector. A value of 0 causes the channel to remain at the last value attained while the model was running.

Initial value vector

The initial value vector must be the same length as the channel vector and should contain the initial voltage values for the output channels. The channels are set to these values between the time the model is downloaded and the time it is started.

Sample time

Enter the base sample time or a multiple of the base sample time (- 1 means sample time is inherited).

PCI slot (-1:autosearch)

If only one board of this type is in the target computer, enter - 1 to locate the board.

If two or more boards of this type are in the target computer, enter the bus number and the PCI slot number of the board associated with this driver block. Use the format **[BusNumber,SlotNumber]**.

To determine the bus number and the PCI slot number, type:

```
tg = slrt;  
getPCIInfo(tg, 'installed')
```

More About

- “Specifying UEI Boards” on page 53-3

External Websites

- www.ueidaq.com

UEI PD2-MF 14-Bit Series Digital Input

PD2-MF 14-Bit Series Digital Input block

Library

Simulink Real-Time Library for UEI

Scaling Input to Output

I/O Module Input	Block Output Data Type	Scaling
TTL	Double	TTL low = 0.0 TTL high = 1.0

Block Parameters

Board type

Select the specific board type from the list provided.

Channel vector

Enter a vector of numbers to specify the input channels. For example, to use the first and third digital input channels, enter

```
[1 3]
```

The channel numbers can occur in arbitrary order. Number the channels beginning with 1 even if this board manufacturer numbers them beginning with 0. The maximum allowable channel number is 16 except for the PD2-AO and PDXI-AO series. For those boards, the maximum channel number is 8.

Sample time

Enter the base sample time or a multiple of the base sample time (-1 means sample time is inherited).

PCI slot (-1:autosearch)

If only one board of this type is in the target computer, enter -1 to locate the board.

If two or more boards of this type are in the target computer, enter the bus number and the PCI slot number of the board associated with this driver block. Use the format **[BusNumber,SlotNumber]**.

To determine the bus number and the PCI slot number, type:

```
tg = slrt;  
getPCIInfo(tg, 'installed')
```

More About

- “Specifying UEI Boards” on page 53-3

External Websites

- www.ueidaq.com

UEI PD2-MF 14-Bit Series Digital Output

PD2-MF 14-Bit Series Digital Output block

Library

Simulink Real-Time Library for UEI

Scaling Input to Output

I/O Module Output	Block Input Data Type	Scaling
TTL	Double	< 0.5 = TTL low > 0.5 = TTL high

Block Parameters

Board type

Select the specific board type from the list provided.

Channel vector

Enter a vector of numbers to specify the output channels. For example, to use the first and third digital output channels, enter

```
[1 3]
```

The channel numbers can occur in arbitrary order. Number the channels beginning with 1 even if this board manufacturer numbers them beginning with 0. The maximum allowable channel number is 16, except for the PD2-AO and PDXI-AO series. For those boards, the maximum channel number is 8.

Reset vector

The reset vector must be the same length as the channel vector. It contains values of 0 or 1. This parameter controls the behavior at model termination. A value of 1 causes the corresponding channel to be reset to the value specified in the initial value vector. A value of 0 causes the channel to remain at the last value attained while the model was running.

Initial value vector

The initial value vector must be the same length as the channel vector. It contains the initial values (0 or 1) for the output channels. The channels are set to these values between the time the model is downloaded and the time it is started.

Sample time

Enter the base sample time or a multiple of the base sample time (- 1 means sample time is inherited).

PCI slot (-1:autosearch)

If only one board of this type is in the target computer, enter - 1 to locate the board.

If two or more boards of this type are in the target computer, enter the bus number and the PCI slot number of the board associated with this driver block. Use the format [**BusNumber,SlotNumber**].

To determine the bus number and the PCI slot number, type:

```
tg = slrt;  
getPCIInfo(tg, 'installed')
```

More About

- “Specifying UEI Boards” on page 53-3

External Websites

- www.ueidaq.com

UEI PD2-MF 16-Bit Series

Support for the UEI PD2-MF 16-Bit Series I/O boards

Board Series

UEI PD2-MF 16-Bit Series

General Board Series Description

The PD2-MF 16-bit series contains I/O boards with 16 or 64 single or 8 or 32 differential analog input (A/D) channels (16-bit). The gain varies from 1 to 8 or 1 to 1000. The boards also have 2 analog output (D/A) channels (12-bit), 16 digital input, and 16 digital output lines. The Simulink Real-Time software does not support the counter/timers on these boards.

The Simulink Real-Time block library supports this series of boards with these driver blocks:

- UEI PD2-MF 16-Bit Series Analog Input (A/D)
- UEI PD2-MF 16-Bit Series Frame Analog Input
- UEI PD2-MF 16-Bit Series Analog Output (D/A)
- UEI PD2-MF 16-Bit Series Digital Input
- UEI PD2-MF 16-Bit Series Digital Output

Board Characteristics

Board type	PD2-MF-16-50/16H
	PD2-MF-16-333/16L
	PD2-MF-16-333/16H
	PD2-MF-64-333/16L
	PD2-MF-64-333/16H
	PD2-MF-16-500/16L
	PD2-MF-16-500/16H
	PD2-MF-64-500/16L
	PD2-MF-64-500/16H

Manufacturer	United Electronic Industries (UEI)
Bus type	PCI
Access method	Memory mapped
Multiple block instance support	No
Multiple board support	Yes

More About

- “Specifying UEI Boards” on page 53-3

External Websites

- www.ueidaq.com

UEI PD2-MF 16-Bit Series Analog Input (A/D)

PD2-MF 16-Bit Series Analog Input block

Library

Simulink Real-Time Library for UEI

Scaling Input to Output

I/O Module Input	Block Output Data Type	Scaling
Volts	Double	1

Block Parameters

Board type

Select the specific board type from the list provided.

Channel vector

Enter a vector of numbers to specify the input channels. For example, use the first and third analog input (A/D) channels, enter

[1 3]

The channel numbers can occur in arbitrary order. Number the channels beginning with 1 even if this board manufacturer numbers them beginning with 0. The maximum allowable channel number is 4, 8, 16, or 64 depending on the board type.

Gain vector

Enter a vector of numbers to select the gains for each of the channels. Available gains vary depending on board type. MF PGL gains may be set to 1, 10, 100, or 1000. MF PGH gains may be set to 1, 2, 4, or 8. MF DG-option gains may be set to 1, 2, 5, or 10.

Mux settling time vector (slow bit)

This vector must be the same length as the channel vector. It contains values of 0 or 1. If 1, the corresponding channel has a longer settling time. This is useful when using a high gain such as 100 or 1000.

Range

Select the voltage range from the list provided. This applies to all channels.

Input coupling mode

From the list, select one from the following list of input coupling modes:

- Single Ended
- Differential

Refer to the UEI PowerDAQ documentation for input connections.

Sample time

Enter the base sample time or a multiple of the base sample time (- 1 means sample time is inherited).

PCI slot (-1:autosearch)

If only one board of this type is in the target computer, enter - 1 to locate the board.

If two or more boards of this type are in the target computer, enter the bus number and the PCI slot number of the board associated with this driver block. Use the format [**BusNumber,SlotNumber**].

To determine the bus number and the PCI slot number, type:

```
tg = slrt;  
getPCIInfo(tg, 'installed')
```

More About

- “Specifying UEI Boards” on page 53-3

External Websites

- www.ueidaq.com

UEI PD2-MF 16-Bit Series Frame Analog Input

PD2-MF 16-Bit Series Frame Analog Input block

Library

Simulink Real-Time Library for UEI

Scaling Input to Output

I/O Module Input	Block Output Data Type	Scaling
Volts	Double	1

Block Parameters

Board type

Select the specific board type from the list provided.

Channel vector

Enter a vector of numbers that make up one scan. For example, to read the first and fifth channels, enter

```
[1 5]
```

The channel numbers can occur in arbitrary order. Number the channels beginning with 1 even if this board manufacturer numbers them beginning with 0. The maximum allowable channel number is 4, 8, 16, or 64 depending on the board type.

Gain vector

Enter a vector of numbers to specify the gains for each of the channels in the scan. Enter a single value to replicate the gain value across the channels in the scan. Available gains vary depending on board type. Allowable values depend on the board type.

- L (Low level) boards — Specify the gain as one of 1, 10, 100, or 1000.
- H (High level) boards — Specify the gain as one of 1, 2, 4, or 8.
- DG-option boards — Specify the gain as one of 1, 2, 5, or 10.

Mux settling time vector (slow bit)

Enter a vector that is the same length as the channel vector. Each vector element must be a 0 or 1. If you specify 1, the corresponding channel has a longer settling time. To get a more accurate reading, you might want to specify a 1 for channels that have higher gains, such as 100 or 1000. Refer to the UEI PowerDAQ documentation for further information on the longer settling time. This time depends on the board type.

Caution With frame based acquisition, the additional time resulting from setting the **Mux settling time vector (slow bit)** might cause an acquisition overrun that the Simulink Real-Time software does not detect. For example, on a PD2-MF-xx-333/16H board, each acquisition takes 3 microseconds if the slow bit is 0. If the slow bit is 1, that same acquisition takes more than 10 microseconds. With the Simulink Real-Time software, the scan is performed at the maximum rate for a given board. This means that the slow acquisition takes a multiple of 3 microsecond ticks. For a PD2-MF-xx-333/16H board, this becomes 12 microseconds.

For example, assume that N scans of the channel vector compose a frame of data. Assume also that you have a PD2-MF-xx-333/16H board with a **Channel vector** value of [1 2 3 4] and a **Mux settling time vector (slow bit)** value of [0 1 0 1]. For the PD2-MF-xx-333/16H board, two of the acquisition delays are 3 microseconds, and two are 12 microseconds. With a **Frame time** value of 0.001 second, if N is greater than 38, the data will not be acceptable. If you set the slow bits to 0, N can have a value of up to 83. The software detects the limit at $N = 83$, but is not aware of the extra board dependent delay.

Range

From the list, select one of the following voltage ranges. The value you select applies to all channels.

- +-10 Volts
- +-5 Volts
- 0-10 Volts
- 0-5 Volts

Input coupling mode

From the list, select one from the following list of input coupling modes:

- Single Ended
- Differential

Refer to the UEI PowerDAQ documentation for input connections.

Frame size

Enter the number of samples per channel to return as a frame of data. Due to physical constraints in the I/O module, the total number of samples in a frame of data cannot exceed 512. The relationship between the number of samples, frame size, and number of channels is

total number of samples = FrameSize x nChannels

For example, if you specify two channels, the frame size must be less than or equal to 256.

Output format

From the list, select either **Frame** or **Vector**.

- **Frame** — Select **Frame** if you expect the output signal from this block to be the input signal for a block that requires a frame. For example, a **Signal Processing** block.
- **Vector** — Select **Vector** if you expect the output signal from this block to be the input signal for a **Simulink Real-Time scope** or some other block that requires vector input.

Scan clock source

Select **Internal** or **External** to identify the clock source for the frame scans.

Scan time

Enter the time (in seconds) between scans as the interval.

Frame time

Enter the interval (in seconds) during which the board will interrupt. The driver block evenly spaces the scans in the frame across the **Frame time** interval. If the **Frame time** interval is too short, you will receive a buffer overrun error at run time. For optimal results, experimentally increase the **Frame time** value and reiterate the process. Rebuild the model when you change this value.

The **Frame size**, **Scan time**, and **Frame time** parameters are not independent, but are related by

$$\text{Frametime} = \text{Framesize} \times \text{Scantime}.$$

After you specify two of the parameters, specify -1 for the third parameter and the equation determines the third parameter.

Note: Because the Simulink Real-Time software uses this value to set parameters on the board, you cannot change the **Frame time** value at the MATLAB prompt.

Block is in an ISR

Select this check box if the block is in an interrupt service routine (ISR). Selecting this check box forces the block sample time to -1 , which enables the block to work in the ISR. If this check box is not selected, the block sample time is equal to the value of **Frame time**.

Slave board

If you have multiple boards configured in a master/slave combination, select this box for the slave boards only. Leave the box unchecked for the master board. (Note that a single board configuration is considered a master board.)

Note: In the model, set the priority of slave blocks higher than master blocks. Right-click the slave or master block and select **Properties**. In the dialog, enter a value in the **Priority** property. For example, if you have multiple slave blocks, you can enter values of 2 for the slave blocks and 3 for the master block, where a lower number indicates a higher priority.

Acquisition frequency

Enter the rate at which the high speed conversion clock runs. This is the clock used to acquire each scan in a frame. For example, with a PD2-MF-xx-333/16H board, the maximum clock is 333 kHz. At that rate, the second channel in a scan will be acquired 3 microseconds after the first one in every scan of the frame.

Specify -1 to select the maximum rate available for the specified board.

DMA burst size

From the list, select either 32, 16, or 8. The DMA engine transfers data in packets of the burst size or less. Between each burst, a new bus arbitration cycle must complete. Better performance is achieved with higher **DMA burst size** values, with 32 being

highest. However, in some architectures and with some PCI bus adaptors, a **DMA burst size** of 32 might cause problems. For example, it might lock up the target computer when DMA is attempted. In these cases, reduce the **DMA burst size** value to 8, rebuild and rerun the real-time application. If the DMA works at 8, select 16 and try again.

PCI slot (-1:autosearch)

If only one board of this type is in the target computer, enter - 1 to locate the board.

If two or more boards of this type are in the target computer, enter the bus number and the PCI slot number of the board associated with this driver block. Use the format **[BusNumber,SlotNumber]**.

To determine the bus number and the PCI slot number, type:

```
tg = slrt;  
getPCIInfo(tg, 'installed')
```

More About

- “Specifying UEI Boards” on page 53-3

External Websites

- www.ueidaq.com

UEI PD2-MF 16-Bit Series Analog Output (D/A)

PD2-MF 16-Bit Series Analog Output block

Library

Simulink Real-Time Library for UEI

Scaling Input to Output

I/O Module Output	Block Input Data Type	Scaling
Volts	Double	1

Block Parameters

Board type

Select the specific board type from the list provided.

Channel vector

Enter a vector of numbers to specify the output channels 1 or 2. For example, to use the first and second analog output (D/A) channels, enter

```
[1 2]
```

The channel numbers can occur in arbitrary order. Number the channels beginning with 1 even if this board manufacturer numbers them beginning with 0.

Reset vector

The reset vector must be the same length as the channel vector. It contains values of 0 or 1. This parameter controls the behavior at model termination. A value of 1 causes the corresponding channel to be reset to the value specified in the initial value vector. A value of 0 causes the channel to remain at the last value attained while the model was running.

Initial value vector

The initial value vector must be the same length as the channel vector and should contain the initial voltage values for the output channels. The channels are set to these values between the time the model is downloaded and the time it is started.

Sample time

Enter the base sample time or a multiple of the base sample time (- 1 means sample time is inherited).

PCI slot (-1:autosearch)

If only one board of this type is in the target computer, enter - 1 to locate the board.

If two or more boards of this type are in the target computer, enter the bus number and the PCI slot number of the board associated with this driver block. Use the format **[BusNumber,SlotNumber]**.

To determine the bus number and the PCI slot number, type:

```
tg = slrt;  
getPCIInfo(tg, 'installed')
```

More About

- “Specifying UEI Boards” on page 53-3

External Websites

- www.ueidaq.com

UEI PD2-MF 16-Bit Series Digital Input

PD2-MF 16-Bit Series Digital Input block

Library

Simulink Real-Time Library for UEI

Scaling Input to Output

I/O Module Input	Block Output Data Type	Scaling
TTL	Double	TTL low = 0.0 TTL high = 1.0

Block Parameters

Board type

Select the specific board type from the list provided.

Channel vector

Enter a vector of numbers to specify the input channels. For example, to use the first and third digital input channels, enter

```
[1 3]
```

The channel numbers can occur in arbitrary order. Number the channels beginning with 1 even if this board manufacturer numbers them beginning with 0. The maximum allowable channel number is 16 except for the PD2-AO and PDXI-AO series. For those boards, the maximum channel number is 8.

Sample time

Enter the base sample time or a multiple of the base sample time (-1 means sample time is inherited).

PCI slot (-1:autosearch)

If only one board of this type is in the target computer, enter -1 to locate the board.

If two or more boards of this type are in the target computer, enter the bus number and the PCI slot number of the board associated with this driver block. Use the format **[BusNumber,SlotNumber]**.

To determine the bus number and the PCI slot number, type:

```
tg = slrt;  
getPCIInfo(tg, 'installed')
```

More About

- “Specifying UEI Boards” on page 53-3

External Websites

- www.ueidaq.com

UEI PD2-MF 16-Bit Series Digital Output

PD2-MF 16-Bit Series Digital Output block

Library

Simulink Real-Time Library for UEI

Scaling Input to Output

I/O Module Output	Block Input Data Type	Scaling
TTL	Double	< 0.5 = TTL low > 0.5 = TTL high

Block Parameters

Board type

Select the specific board type from the list provided.

Channel vector

Enter a vector of numbers to specify the output channels. For example, to use the first and third digital output channels, enter

```
[1 3]
```

The channel numbers can occur in arbitrary order. Number the channels beginning with 1 even if this board manufacturer numbers them beginning with 0. The maximum allowable channel number is 16, except for the PD2-AO and PDXI-AO series. For those boards, the maximum channel number is 8.

Reset vector

The reset vector must be the same length as the channel vector. It contains values of 0 or 1. This parameter controls the behavior at model termination. A value of 1 causes the corresponding channel to be reset to the value specified in the initial value vector. A value of 0 causes the channel to remain at the last value attained while the model was running.

Initial value vector

The initial value vector must be the same length as the channel vector. It contains the initial values (0 or 1) for the output channels. The channels are set to these values between the time the model is downloaded and the time it is started.

Sample time

Enter the base sample time or a multiple of the base sample time (- 1 means sample time is inherited).

PCI slot (-1:autosearch)

If only one board of this type is in the target computer, enter - 1 to locate the board.

If two or more boards of this type are in the target computer, enter the bus number and the PCI slot number of the board associated with this driver block. Use the format [**BusNumber,SlotNumber**].

To determine the bus number and the PCI slot number, type:

```
tg = slrt;  
getPCIInfo(tg, 'installed')
```

More About

- “Specifying UEI Boards” on page 53-3

External Websites

- www.ueidaq.com

UEI PD2-MFS 12-Bit Series

Support for the UEI PD2-MFS 12-Bit Series I/O boards

Board Series

UEI PD2-MFS 12-Bit Series

General Board Series Description

The PD2-MFS 12-bit series contains I/O boards with 4 or 8 single analog input (A/D) channels (12-bit). The boards also have 2 analog output (D/A) channels (12-bit), 16 digital input, and 16 digital output lines. The Simulink Real-Time software does not support the counter/timers on these boards.

The Simulink Real-Time block library supports this series of boards with these driver blocks:

- UEI PD2-MFS 12-Bit Series Analog Input (A/D)
- UEI PD2-MFS 12-Bit Series Frame Analog Input
- UEI PD2-MFS 12-Bit Series Analog Output (D/A)
- UEI PD2-MFS 12-Bit Series Digital Input
- UEI PD2-MFS 12-Bit Series Digital Output

Board Characteristics

Board type	PD2-MFS-4-1M/12 PD2-MFS-4-1M/12DG PD2-MFS-8-1M/12 PD2-MFS-8-1M/12DG
Manufacturer	United Electronic Industries (UEI)
Bus type	PCI
Access method	Memory mapped

Multiple block instance support	No
Multiple board support	Yes

More About

- “Specifying UEI Boards” on page 53-3

External Websites

- www.ueidaq.com

UEI PD2-MFS 12-Bit Series Analog Input (A/D)

PD2-MFS 12-Bit Series Analog Input block

Library

Simulink Real-Time Library for UEI

Scaling Input to Output

I/O Module Input	Block Output Data Type	Scaling
Volts	Double	1

Block Parameters

Board type

Select the specific board type from the list provided.

Channel vector

Enter a vector of numbers to specify the input channels. For example, use the first and third analog input (A/D) channels, enter

[1 3]

The channel numbers can occur in arbitrary order. Number the channels beginning with 1 even if this board manufacturer numbers them beginning with 0. The maximum allowable channel number is 4, 8, 16, or 64 depending on the board type.

Gain vector

Enter a vector of numbers to select the gains for each of the channels. Available gains vary depending on board type. MF PGL gains may be set to 1, 10, 100, or 1000. MF PGH gains may be set to 1, 2, 4, or 8. MF DG-option gains may be set to 1, 2, 5, or 10.

Mux settling time vector (slow bit)

This vector must be the same length as the channel vector. It contains values of 0 or 1. If 1, the corresponding channel has a longer settling time. This is useful when using a high gain such as 100 or 1000.

Range

Select the voltage range from the list provided. This applies to all channels.

Input coupling mode

From the list, select one from the following list of input coupling modes:

- Single Ended
- Differential

Refer to the UEI PowerDAQ documentation for input connections.

Sample time

Enter the base sample time or a multiple of the base sample time (- 1 means sample time is inherited).

PCI slot (-1:autosearch)

If only one board of this type is in the target computer, enter - 1 to locate the board.

If two or more boards of this type are in the target computer, enter the bus number and the PCI slot number of the board associated with this driver block. Use the format [**BusNumber,SlotNumber**].

To determine the bus number and the PCI slot number, type:

```
tg = slrt;  
getPCIInfo(tg, 'installed')
```

More About

- “Specifying UEI Boards” on page 53-3

External Websites

- www.ueidaq.com

UEI PD2-MFS 12-Bit Series Frame Analog Input

PD2-MFS 12-Bit Series Frame Analog Input block

Library

Simulink Real-Time Library for UEI

Scaling Input to Output

I/O Module Input	Block Output Data Type	Scaling
Volts	Double	1

Block Parameters

Board type

Select the specific board type from the list provided.

Channel vector

Enter a vector of numbers that make up one scan. For example, to read the first and fifth channels, enter

```
[1 5]
```

The channel numbers can occur in arbitrary order. Number the channels beginning with 1 even if this board manufacturer numbers them beginning with 0. The maximum allowable channel number is 4, 8, 16, or 64 depending on the board type.

Gain vector

Enter a vector of numbers to specify the gains for each of the channels in the scan.

Enter a single value to replicate the gain value across the channels in the scan.

Available gains vary depending on board type. Allowable values depend on the board type.

- L (Low level) boards — Specify the gain as one of 1, 10, 100, or 1000.
- H (High level) boards — Specify the gain as one of 1, 2, 4, or 8.
- DG-option boards — Specify the gain as one of 1, 2, 5, or 10.

Mux settling time vector (slow bit)

Enter a vector that is the same length as the channel vector. Each vector element must be a 0 or 1. If you specify 1, the corresponding channel has a longer settling time. To get a more accurate reading, you might want to specify a 1 for channels that have higher gains, such as 100 or 1000. Refer to the UEI PowerDAQ documentation for further information on the longer settling time. This time depends on the board type.

Caution With frame based acquisition, the additional time resulting from setting the **Mux settling time vector (slow bit)** might cause an acquisition overrun that the Simulink Real-Time software does not detect. For example, on a PD2-MF-xx-333/16H board, each acquisition takes 3 microseconds if the slow bit is 0. If the slow bit is 1, that same acquisition takes more than 10 microseconds. With the Simulink Real-Time software, the scan is performed at the maximum rate for a given board. This means that the slow acquisition takes a multiple of 3 microsecond ticks. For a PD2-MF-xx-333/16H board, this becomes 12 microseconds.

For example, assume that N scans of the channel vector compose a frame of data. Assume also that you have a PD2-MF-xx-333/16H board with a **Channel vector** value of [1 2 3 4] and a **Mux settling time vector (slow bit)** value of [0 1 0 1]. For the PD2-MF-xx-333/16H board, two of the acquisition delays are 3 microseconds, and two are 12 microseconds. With a **Frame time** value of 0.001 second, if N is greater than 38, the data will not be acceptable. If you set the slow bits to 0, N can have a value of up to 83. The software detects the limit at $N = 83$, but is not aware of the extra board dependent delay.

Range

From the list, select one of the following voltage ranges. The value you select applies to all channels.

- +-10 Volts
- +-5 Volts
- 0-10 Volts
- 0-5 Volts

Input coupling mode

From the list, select one from the following list of input coupling modes:

- Single Ended
- Differential

Refer to the UEI PowerDAQ documentation for input connections.

Frame size

Enter the number of samples per channel to return as a frame of data. Due to physical constraints in the I/O module, the total number of samples in a frame of data cannot exceed 512. The relationship between the number of samples, frame size, and number of channels is

$$\text{total number of samples} = \text{FrameSize} \times \text{nChannels}$$

For example, if you specify two channels, the frame size must be less than or equal to 256.

Output format

From the list, select either **Frame** or **Vector**.

- **Frame** — Select **Frame** if you expect the output signal from this block to be the input signal for a block that requires a frame. For example, a **Signal Processing** block.
- **Vector** — Select **Vector** if you expect the output signal from this block to be the input signal for a **Simulink Real-Time scope** or some other block that requires vector input.

Scan clock source

Select **Internal** or **External** to identify the clock source for the frame scans.

Scan time

Enter the time (in seconds) between scans as the interval.

Frame time

Enter the interval (in seconds) during which the board will interrupt. The driver block evenly spaces the scans in the frame across the **Frame time** interval. If the **Frame time** interval is too short, you will receive a buffer overrun error at run time. For optimal results, experimentally increase the **Frame time** value and reiterate the process. Rebuild the model when you change this value.

The **Frame size**, **Scan time**, and **Frame time** parameters are not independent, but are related by

$$\text{Frametime} = \text{Framesize} \times \text{Scantime}.$$

After you specify two of the parameters, specify -1 for the third parameter and the equation determines the third parameter.

Note: Because the Simulink Real-Time software uses this value to set parameters on the board, you cannot change the **Frame time** value at the MATLAB prompt.

Block is in an ISR

Select this check box if the block is in an interrupt service routine (ISR). Selecting this check box forces the block sample time to -1 , which enables the block to work in the ISR. If this check box is not selected, the block sample time is equal to the value of **Frame time**.

Slave board

If you have multiple boards configured in a master/slave combination, select this box for the slave boards only. Leave the box unchecked for the master board. (Note that a single board configuration is considered a master board.)

Note: In the model, set the priority of slave blocks higher than master blocks. Right-click the slave or master block and select **Properties**. In the dialog, enter a value in the **Priority** property. For example, if you have multiple slave blocks, you can enter values of 2 for the slave blocks and 3 for the master block, where a lower number indicates a higher priority.

Acquisition frequency

Enter the rate at which the high speed conversion clock runs. This is the clock used to acquire each scan in a frame. For example, with a PD2-MF-xx-333/16H board, the maximum clock is 333 kHz. At that rate, the second channel in a scan will be acquired 3 microseconds after the first one in every scan of the frame.

Specify -1 to select the maximum rate available for the specified board.

DMA burst size

From the list, select either 32, 16, or 8. The DMA engine transfers data in packets of the burst size or less. Between each burst, a new bus arbitration cycle must complete. Better performance is achieved with higher **DMA burst size** values, with 32 being

highest. However, in some architectures and with some PCI bus adaptors, a **DMA burst size** of 32 might cause problems. For example, it might lock up the target computer when DMA is attempted. In these cases, reduce the **DMA burst size** value to 8, rebuild and rerun the real-time application. If the DMA works at 8, select 16 and try again.

PCI slot (-1:autosearch)

If only one board of this type is in the target computer, enter - 1 to locate the board.

If two or more boards of this type are in the target computer, enter the bus number and the PCI slot number of the board associated with this driver block. Use the format **[BusNumber,SlotNumber]**.

To determine the bus number and the PCI slot number, type:

```
tg = slrt;  
getPCIInfo(tg, 'installed')
```

More About

- “Specifying UEI Boards” on page 53-3

External Websites

- www.ueidaq.com

UEI PD2-MFS 12-Bit Series Analog Output (D/A)

PD2-MFS 12-Bit Series Analog Output block

Library

Simulink Real-Time Library for UEI

Scaling Input to Output

I/O Module Output	Block Input Data Type	Scaling
Volts	Double	1

Block Parameters

Board type

Select the specific board type from the list provided.

Channel vector

Enter a vector of numbers to specify the output channels 1 or 2. For example, to use the first and second analog output (D/A) channels, enter

```
[1 2]
```

The channel numbers can occur in arbitrary order. Number the channels beginning with 1 even if this board manufacturer numbers them beginning with 0.

Reset vector

The reset vector must be the same length as the channel vector. It contains values of 0 or 1. This parameter controls the behavior at model termination. A value of 1 causes the corresponding channel to be reset to the value specified in the initial value vector. A value of 0 causes the channel to remain at the last value attained while the model was running.

Initial value vector

The initial value vector must be the same length as the channel vector and should contain the initial voltage values for the output channels. The channels are set to these values between the time the model is downloaded and the time it is started.

Sample time

Enter the base sample time or a multiple of the base sample time (- 1 means sample time is inherited).

PCI slot (-1:autosearch)

If only one board of this type is in the target computer, enter - 1 to locate the board.

If two or more boards of this type are in the target computer, enter the bus number and the PCI slot number of the board associated with this driver block. Use the format **[BusNumber,SlotNumber]**.

To determine the bus number and the PCI slot number, type:

```
tg = slrt;  
getPCIInfo(tg, 'installed')
```

More About

- “Specifying UEI Boards” on page 53-3

External Websites

- www.ueidaq.com

UEI PD2-MFS 12-Bit Series Digital Input

PD2-MFS 12-Bit Series Digital Input block

Library

Simulink Real-Time Library for UEI

Scaling Input to Output

I/O Module Input	Block Output Data Type	Scaling
TTL	Double	TTL low = 0.0 TTL high = 1.0

Block Parameters

Board type

Select the specific board type from the list provided.

Channel vector

Enter a vector of numbers to specify the input channels. For example, to use the first and third digital input channels, enter

```
[1 3]
```

The channel numbers can occur in arbitrary order. Number the channels beginning with 1 even if this board manufacturer numbers them beginning with 0. The maximum allowable channel number is 16 except for the PD2-AO and PDXI-AO series. For those boards, the maximum channel number is 8.

Sample time

Enter the base sample time or a multiple of the base sample time (-1 means sample time is inherited).

PCI slot (-1:autosearch)

If only one board of this type is in the target computer, enter -1 to locate the board.

If two or more boards of this type are in the target computer, enter the bus number and the PCI slot number of the board associated with this driver block. Use the format **[BusNumber,SlotNumber]**.

To determine the bus number and the PCI slot number, type:

```
tg = slrt;  
getPCIInfo(tg, 'installed')
```

More About

- “Specifying UEI Boards” on page 53-3

External Websites

- www.ueidaq.com

UEI PD2-MFS 12-Bit Series Digital Output

PD2-MFS 12-Bit Series Digital Output block

Library

Simulink Real-Time Library for UEI

Scaling Input to Output

I/O Module Output	Block Input Data Type	Scaling
TTL	Double	< 0.5 = TTL low > 0.5 = TTL high

Block Parameters

Board type

Select the specific board type from the list provided.

Channel vector

Enter a vector of numbers to specify the output channels. For example, to use the first and third digital output channels, enter

```
[1 3]
```

The channel numbers can occur in arbitrary order. Number the channels beginning with 1 even if this board manufacturer numbers them beginning with 0. The maximum allowable channel number is 16, except for the PD2-AO and PDXI-AO series. For those boards, the maximum channel number is 8.

Reset vector

The reset vector must be the same length as the channel vector. It contains values of 0 or 1. This parameter controls the behavior at model termination. A value of 1 causes the corresponding channel to be reset to the value specified in the initial value vector. A value of 0 causes the channel to remain at the last value attained while the model was running.

Initial value vector

The initial value vector must be the same length as the channel vector. It contains the initial values (0 or 1) for the output channels. The channels are set to these values between the time the model is downloaded and the time it is started.

Sample time

Enter the base sample time or a multiple of the base sample time (- 1 means sample time is inherited).

PCI slot (-1:autosearch)

If only one board of this type is in the target computer, enter - 1 to locate the board.

If two or more boards of this type are in the target computer, enter the bus number and the PCI slot number of the board associated with this driver block. Use the format [**BusNumber,SlotNumber**].

To determine the bus number and the PCI slot number, type:

```
tg = slrt;  
getPCIInfo(tg, 'installed')
```

More About

- “Specifying UEI Boards” on page 53-3

External Websites

- www.ueidaq.com

UEI PD2-MFS 14-Bit Series

Support for the EI PD2-MFS 14-Bit Series I/O boards

Board Series

UEI PD2-MFS 14-Bit Series

General Board Series Description

The PD2-MFS 14-bit series contains I/O boards with 4 or 8 single analog input (A/D) channels (14-bit). The boards also have 2 analog output (D/A) channels (12-bit), 16 digital input, and 16 digital output lines. The Simulink Real-Time software does not support the counter/timers on these boards.

The Simulink Real-Time block library supports this series of boards with these driver blocks:

- UEI PD2-MFS 14-Bit Series Analog Input (A/D)
- UEI PD2-MFS 14-Bit Series Frame Analog Input
- UEI PD2-MFS 14-Bit Series Analog Output (D/A)
- UEI PD2-MFS 14-Bit Series Digital Input
- UEI PD2-MFS 14-Bit Series Digital Output

Board Characteristics

Board type	PD2-MFS-4-500/14
	PD2-MFS-4-500/14DG
	PD2-MFS-8-500/14
	PD2-MFS-8-500/14DG
	PD2-MFS-4-800/14
	PD2-MFS-4-800/14DG
	PD2-MFS-8-800/14
	PD2-MFS-8-800/14DG
	PD2-MFS-4-2M/14

	PD2-MFS-4-2M/14DG
	PD2-MFS-8-2M/14
	PD2-MFS-8-2M/14DG
Manufacturer	United Electronic Industries (UEI)
Bus type	PCI
Access method	Memory mapped
Multiple block instance support	No
Multiple board support	Yes

More About

- “Specifying UEI Boards” on page 53-3

External Websites

- www.ueidaq.com

UEI PD2-MFS 14-Bit Series Analog Input (A/D)

PD2-MFS 14-Bit Series Analog Input block

Library

Simulink Real-Time Library for UEI

Scaling Input to Output

I/O Module Input	Block Output Data Type	Scaling
Volts	Double	1

Block Parameters

Board type

Select the specific board type from the list provided.

Channel vector

Enter a vector of numbers to specify the input channels. For example, use the first and third analog input (A/D) channels, enter

[1 3]

The channel numbers can occur in arbitrary order. Number the channels beginning with 1 even if this board manufacturer numbers them beginning with 0. The maximum allowable channel number is 4, 8, 16, or 64 depending on the board type.

Gain vector

Enter a vector of numbers to select the gains for each of the channels. Available gains vary depending on board type. MF PGL gains may be set to 1, 10, 100, or 1000. MF PGH gains may be set to 1, 2, 4, or 8. MF DG-option gains may be set to 1, 2, 5, or 10.

Mux settling time vector (slow bit)

This vector must be the same length as the channel vector. It contains values of 0 or 1. If 1, the corresponding channel has a longer settling time. This is useful when using a high gain such as 100 or 1000.

Range

Select the voltage range from the list provided. This applies to all channels.

Input coupling mode

From the list, select one from the following list of input coupling modes:

- Single Ended
- Differential

Refer to the UEI PowerDAQ documentation for input connections.

Sample time

Enter the base sample time or a multiple of the base sample time (- 1 means sample time is inherited).

PCI slot (-1:autosearch)

If only one board of this type is in the target computer, enter - 1 to locate the board.

If two or more boards of this type are in the target computer, enter the bus number and the PCI slot number of the board associated with this driver block. Use the format [**BusNumber,SlotNumber**].

To determine the bus number and the PCI slot number, type:

```
tg = slrt;  
getPCIInfo(tg, 'installed')
```

More About

- “Specifying UEI Boards” on page 53-3

External Websites

- www.ueidaq.com

UEI PD2-MFS 14-Bit Series Frame Analog Input

PD2-MFS 14-Bit Series Frame Analog Input block

Library

Simulink Real-Time Library for UEI

Scaling Input to Output

I/O Module Input	Block Output Data Type	Scaling
Volts	Double	1

Block Parameters

Board type

Select the specific board type from the list provided.

Channel vector

Enter a vector of numbers that make up one scan. For example, to read the first and fifth channels, enter

```
[1 5]
```

The channel numbers can occur in arbitrary order. Number the channels beginning with 1 even if this board manufacturer numbers them beginning with 0. The maximum allowable channel number is 4, 8, 16, or 64 depending on the board type.

Gain vector

Enter a vector of numbers to specify the gains for each of the channels in the scan.

Enter a single value to replicate the gain value across the channels in the scan.

Available gains vary depending on board type. Allowable values depend on the board type.

- L (Low level) boards — Specify the gain as one of 1, 10, 100, or 1000.
- H (High level) boards — Specify the gain as one of 1, 2, 4, or 8.
- DG-option boards — Specify the gain as one of 1, 2, 5, or 10.

Mux settling time vector (slow bit)

Enter a vector that is the same length as the channel vector. Each vector element must be a 0 or 1. If you specify 1, the corresponding channel has a longer settling time. To get a more accurate reading, you might want to specify a 1 for channels that have higher gains, such as 100 or 1000. Refer to the UEI PowerDAQ documentation for further information on the longer settling time. This time depends on the board type.

Caution With frame based acquisition, the additional time resulting from setting the **Mux settling time vector (slow bit)** might cause an acquisition overrun that the Simulink Real-Time software does not detect. For example, on a PD2-MF-xx-333/16H board, each acquisition takes 3 microseconds if the slow bit is 0. If the slow bit is 1, that same acquisition takes more than 10 microseconds. With the Simulink Real-Time software, the scan is performed at the maximum rate for a given board. This means that the slow acquisition takes a multiple of 3 microsecond ticks. For a PD2-MF-xx-333/16H board, this becomes 12 microseconds.

For example, assume that N scans of the channel vector compose a frame of data. Assume also that you have a PD2-MF-xx-333/16H board with a **Channel vector** value of [1 2 3 4] and a **Mux settling time vector (slow bit)** value of [0 1 0 1]. For the PD2-MF-xx-333/16H board, two of the acquisition delays are 3 microseconds, and two are 12 microseconds. With a **Frame time** value of 0.001 second, if N is greater than 38, the data will not be acceptable. If you set the slow bits to 0, N can have a value of up to 83. The software detects the limit at $N = 83$, but is not aware of the extra board dependent delay.

Range

From the list, select one of the following voltage ranges. The value you select applies to all channels.

- +-10 Volts
- +-5 Volts
- 0-10 Volts
- 0-5 Volts

Input coupling mode

From the list, select one from the following list of input coupling modes:

- Single Ended
- Differential

Refer to the UEI PowerDAQ documentation for input connections.

Frame size

Enter the number of samples per channel to return as a frame of data. Due to physical constraints in the I/O module, the total number of samples in a frame of data cannot exceed 512. The relationship between the number of samples, frame size, and number of channels is

$$\text{total number of samples} = \text{FrameSize} \times \text{nChannels}$$

For example, if you specify two channels, the frame size must be less than or equal to 256.

Output format

From the list, select either **Frame** or **Vector**.

- **Frame** — Select **Frame** if you expect the output signal from this block to be the input signal for a block that requires a frame. For example, a **Signal Processing** block.
- **Vector** — Select **Vector** if you expect the output signal from this block to be the input signal for a **Simulink Real-Time scope** or some other block that requires vector input.

Scan clock source

Select **Internal** or **External** to identify the clock source for the frame scans.

Scan time

Enter the time (in seconds) between scans as the interval.

Frame time

Enter the interval (in seconds) during which the board will interrupt. The driver block evenly spaces the scans in the frame across the **Frame time** interval. If the **Frame time** interval is too short, you will receive a buffer overrun error at run time. For optimal results, experimentally increase the **Frame time** value and reiterate the process. Rebuild the model when you change this value.

The **Frame size**, **Scan time**, and **Frame time** parameters are not independent, but are related by

$$\text{Frametime} = \text{Framesize} \times \text{Scantime}.$$

After you specify two of the parameters, specify -1 for the third parameter and the equation determines the third parameter.

Note: Because the Simulink Real-Time software uses this value to set parameters on the board, you cannot change the **Frame time** value at the MATLAB prompt.

Block is in an ISR

Select this check box if the block is in an interrupt service routine (ISR). Selecting this check box forces the block sample time to -1 , which enables the block to work in the ISR. If this check box is not selected, the block sample time is equal to the value of **Frame time**.

Slave board

If you have multiple boards configured in a master/slave combination, select this box for the slave boards only. Leave the box unchecked for the master board. (Note that a single board configuration is considered a master board.)

Note: In the model, set the priority of slave blocks higher than master blocks. Right-click the slave or master block and select **Properties**. In the dialog, enter a value in the **Priority** property. For example, if you have multiple slave blocks, you can enter values of 2 for the slave blocks and 3 for the master block, where a lower number indicates a higher priority.

Acquisition frequency

Enter the rate at which the high speed conversion clock runs. This is the clock used to acquire each scan in a frame. For example, with a PD2-MF-xx-333/16H board, the maximum clock is 333 kHz. At that rate, the second channel in a scan will be acquired 3 microseconds after the first one in every scan of the frame.

Specify -1 to select the maximum rate available for the specified board.

DMA burst size

From the list, select either 32, 16, or 8. The DMA engine transfers data in packets of the burst size or less. Between each burst, a new bus arbitration cycle must complete. Better performance is achieved with higher **DMA burst size** values, with 32 being

highest. However, in some architectures and with some PCI bus adaptors, a **DMA burst size** of 32 might cause problems. For example, it might lock up the target computer when DMA is attempted. In these cases, reduce the **DMA burst size** value to 8, rebuild and rerun the real-time application. If the DMA works at 8, select 16 and try again.

PCI slot (-1:autosearch)

If only one board of this type is in the target computer, enter - 1 to locate the board.

If two or more boards of this type are in the target computer, enter the bus number and the PCI slot number of the board associated with this driver block. Use the format **[BusNumber,SlotNumber]**.

To determine the bus number and the PCI slot number, type:

```
tg = slrt;  
getPCIInfo(tg, 'installed')
```

More About

- “Specifying UEI Boards” on page 53-3

External Websites

- www.ueidaq.com

UEI PD2-MFS 14-Bit Series Analog Output (D/A)

PD2-MFS 14-Bit Series Analog Output block

Library

Simulink Real-Time Library for UEI

Scaling Input to Output

I/O Module Output	Block Input Data Type	Scaling
Volts	Double	1

Block Parameters

Board type

Select the specific board type from the list provided.

Channel vector

Enter a vector of numbers to specify the output channels 1 or 2. For example, to use the first and second analog output (D/A) channels, enter

```
[1 2]
```

The channel numbers can occur in arbitrary order. Number the channels beginning with 1 even if this board manufacturer numbers them beginning with 0.

Reset vector

The reset vector must be the same length as the channel vector. It contains values of 0 or 1. This parameter controls the behavior at model termination. A value of 1 causes the corresponding channel to be reset to the value specified in the initial value vector. A value of 0 causes the channel to remain at the last value attained while the model was running.

Initial value vector

The initial value vector must be the same length as the channel vector and should contain the initial voltage values for the output channels. The channels are set to these values between the time the model is downloaded and the time it is started.

Sample time

Enter the base sample time or a multiple of the base sample time (- 1 means sample time is inherited).

PCI slot (-1:autosearch)

If only one board of this type is in the target computer, enter - 1 to locate the board.

If two or more boards of this type are in the target computer, enter the bus number and the PCI slot number of the board associated with this driver block. Use the format **[BusNumber,SlotNumber]**.

To determine the bus number and the PCI slot number, type:

```
tg = slrt;  
getPCIInfo(tg, 'installed')
```

More About

- “Specifying UEI Boards” on page 53-3

External Websites

- www.ueidaq.com

UEI PD2-MFS 14-Bit Series Digital Input

PD2-MFS 14-Bit Series Digital Input block

Library

Simulink Real-Time Library for UEI

Scaling Input to Output

I/O Module Input	Block Output Data Type	Scaling
TTL	Double	TTL low = 0.0 TTL high = 1.0

Block Parameters

Board type

Select the specific board type from the list provided.

Channel vector

Enter a vector of numbers to specify the input channels. For example, to use the first and third digital input channels, enter

```
[1 3]
```

The channel numbers can occur in arbitrary order. Number the channels beginning with 1 even if this board manufacturer numbers them beginning with 0. The maximum allowable channel number is 16 except for the PD2-AO and PDXI-AO series. For those boards, the maximum channel number is 8.

Sample time

Enter the base sample time or a multiple of the base sample time (-1 means sample time is inherited).

PCI slot (-1:autosearch)

If only one board of this type is in the target computer, enter -1 to locate the board.

If two or more boards of this type are in the target computer, enter the bus number and the PCI slot number of the board associated with this driver block. Use the format **[BusNumber,SlotNumber]**.

To determine the bus number and the PCI slot number, type:

```
tg = slrt;  
getPCIInfo(tg, 'installed')
```

More About

- “Specifying UEI Boards” on page 53-3

External Websites

- www.ueidaq.com

UEI PD2-MFS 14-Bit Series Digital Output

PD2-MFS 14-Bit Series Digital Output block

Library

Simulink Real-Time Library for UEI

Scaling Input to Output

I/O Module Output	Block Input Data Type	Scaling
TTL	Double	< 0.5 = TTL low > 0.5 = TTL high

Block Parameters

Board type

Select the specific board type from the list provided.

Channel vector

Enter a vector of numbers to specify the output channels. For example, to use the first and third digital output channels, enter

```
[1 3]
```

The channel numbers can occur in arbitrary order. Number the channels beginning with 1 even if this board manufacturer numbers them beginning with 0. The maximum allowable channel number is 16, except for the PD2-AO and PDXI-AO series. For those boards, the maximum channel number is 8.

Reset vector

The reset vector must be the same length as the channel vector. It contains values of 0 or 1. This parameter controls the behavior at model termination. A value of 1 causes the corresponding channel to be reset to the value specified in the initial value vector. A value of 0 causes the channel to remain at the last value attained while the model was running.

Initial value vector

The initial value vector must be the same length as the channel vector. It contains the initial values (0 or 1) for the output channels. The channels are set to these values between the time the model is downloaded and the time it is started.

Sample time

Enter the base sample time or a multiple of the base sample time (- 1 means sample time is inherited).

PCI slot (-1:autosearch)

If only one board of this type is in the target computer, enter - 1 to locate the board.

If two or more boards of this type are in the target computer, enter the bus number and the PCI slot number of the board associated with this driver block. Use the format [**BusNumber,SlotNumber**].

To determine the bus number and the PCI slot number, type:

```
tg = slrt;  
getPCIInfo(tg, 'installed')
```

More About

- “Specifying UEI Boards” on page 53-3

External Websites

- www.ueidaq.com

UEI PD2-MFS 16-Bit Series

Support for the UEI PD2-MFS 16-Bit Series I/O boards

Board Series

UEI PD2-MFS 16-Bit Series

General Board Series Description

The PD2-MFS 16-bit series contains I/O boards with 4 or 8 single analog input (A/D) channels (16-bit). The boards also have 2 analog output (D/A) channels (12-bit), 16 digital input, and 16 digital output lines. The Simulink Real-Time software does not support the counter/timers on these boards.

The Simulink Real-Time block library supports this series of boards with these driver blocks:

- UEI PD2-MFS 16-Bit Series Analog Input (A/D)
- UEI PD2-MFS 16-Bit Series Frame Analog Input
- UEI PD2-MFS 16-Bit Series Analog Output (D/A)
- UEI PD2-MFS 16-Bit Series Digital Input
- UEI PD2-MFS 16-Bit Series Digital Output

Board Characteristics

Board type	PD2-MFS-4-300/16
	PD2-MFS-4-300/16DG
	PD2-MFS-8-300/16
	PD2-MFS-8-300/16DG
	PD2-MFS-4-500/16
	PD2-MFS-4-500/16DG
	PD2-MFS-8-500/16
	PD2-MFS-8-500/16DG

Manufacturer	United Electronic Industries (UEI)
Bus type	PCI
Access method	Memory mapped
Multiple block instance support	No
Multiple board support	Yes

More About

- “Specifying UEI Boards” on page 53-3

External Websites

- www.ueidaq.com

UEI PD2-MFS 16-Bit Series Analog Input (A/D)

PD2-MFS 16-Bit Series Analog Input block

Library

Simulink Real-Time Library for UEI

Scaling Input to Output

I/O Module Input	Block Output Data Type	Scaling
Volts	Double	1

Block Parameters

Board type

Select the specific board type from the list provided.

Channel vector

Enter a vector of numbers to specify the input channels. For example, use the first and third analog input (A/D) channels, enter

[1 3]

The channel numbers can occur in arbitrary order. Number the channels beginning with 1 even if this board manufacturer numbers them beginning with 0. The maximum allowable channel number is 4, 8, 16, or 64 depending on the board type.

Gain vector

Enter a vector of numbers to select the gains for each of the channels. Available gains vary depending on board type. MF PGL gains may be set to 1, 10, 100, or 1000. MF PGH gains may be set to 1, 2, 4, or 8. MF DG-option gains may be set to 1, 2, 5, or 10.

Mux settling time vector (slow bit)

This vector must be the same length as the channel vector. It contains values of 0 or 1. If 1, the corresponding channel has a longer settling time. This is useful when using a high gain such as 100 or 1000.

Range

Select the voltage range from the list provided. This applies to all channels.

Input coupling mode

From the list, select one from the following list of input coupling modes:

- Single Ended
- Differential

Refer to the UEI PowerDAQ documentation for input connections.

Sample time

Enter the base sample time or a multiple of the base sample time (- 1 means sample time is inherited).

PCI slot (-1:autosearch)

If only one board of this type is in the target computer, enter - 1 to locate the board.

If two or more boards of this type are in the target computer, enter the bus number and the PCI slot number of the board associated with this driver block. Use the format [**BusNumber,SlotNumber**].

To determine the bus number and the PCI slot number, type:

```
tg = slrt;  
getPCIInfo(tg, 'installed')
```

More About

- “Specifying UEI Boards” on page 53-3

External Websites

- www.ueidaq.com

UEI PD2-MFS 16-Bit Series Frame Analog Input

PD2-MFS 16-Bit Series Frame Analog Input block

Library

Simulink Real-Time Library for UEI

Scaling Input to Output

I/O Module Input	Block Output Data Type	Scaling
Volts	Double	1

Block Parameters

Board type

Select the specific board type from the list provided.

Channel vector

Enter a vector of numbers that make up one scan. For example, to read the first and fifth channels, enter

```
[1 5]
```

The channel numbers can occur in arbitrary order. Number the channels beginning with 1 even if this board manufacturer numbers them beginning with 0. The maximum allowable channel number is 4, 8, 16, or 64 depending on the board type.

Gain vector

Enter a vector of numbers to specify the gains for each of the channels in the scan.

Enter a single value to replicate the gain value across the channels in the scan.

Available gains vary depending on board type. Allowable values depend on the board type.

- L (Low level) boards — Specify the gain as one of 1, 10, 100, or 1000.
- H (High level) boards — Specify the gain as one of 1, 2, 4, or 8.
- DG-option boards — Specify the gain as one of 1, 2, 5, or 10.

Mux settling time vector (slow bit)

Enter a vector that is the same length as the channel vector. Each vector element must be a 0 or 1. If you specify 1, the corresponding channel has a longer settling time. To get a more accurate reading, you might want to specify a 1 for channels that have higher gains, such as 100 or 1000. Refer to the UEI PowerDAQ documentation for further information on the longer settling time. This time depends on the board type.

Caution With frame based acquisition, the additional time resulting from setting the **Mux settling time vector (slow bit)** might cause an acquisition overrun that the Simulink Real-Time software does not detect. For example, on a PD2-MF-xx-333/16H board, each acquisition takes 3 microseconds if the slow bit is 0. If the slow bit is 1, that same acquisition takes more than 10 microseconds. With the Simulink Real-Time software, the scan is performed at the maximum rate for a given board. This means that the slow acquisition takes a multiple of 3 microsecond ticks. For a PD2-MF-xx-333/16H board, this becomes 12 microseconds.

For example, assume that N scans of the channel vector compose a frame of data. Assume also that you have a PD2-MF-xx-333/16H board with a **Channel vector** value of [1 2 3 4] and a **Mux settling time vector (slow bit)** value of [0 1 0 1]. For the PD2-MF-xx-333/16H board, two of the acquisition delays are 3 microseconds, and two are 12 microseconds. With a **Frame time** value of 0.001 second, if N is greater than 38, the data will not be acceptable. If you set the slow bits to 0, N can have a value of up to 83. The software detects the limit at $N = 83$, but is not aware of the extra board dependent delay.

Range

From the list, select one of the following voltage ranges. The value you select applies to all channels.

- +-10 Volts
- +-5 Volts
- 0-10 Volts
- 0-5 Volts

Input coupling mode

From the list, select one from the following list of input coupling modes:

- Single Ended
- Differential

Refer to the UEI PowerDAQ documentation for input connections.

Frame size

Enter the number of samples per channel to return as a frame of data. Due to physical constraints in the I/O module, the total number of samples in a frame of data cannot exceed 512. The relationship between the number of samples, frame size, and number of channels is

$$\text{total number of samples} = \text{FrameSize} \times \text{nChannels}$$

For example, if you specify two channels, the frame size must be less than or equal to 256.

Output format

From the list, select either **Frame** or **Vector**.

- **Frame** — Select **Frame** if you expect the output signal from this block to be the input signal for a block that requires a frame. For example, a Signal Processing block.
- **Vector** — Select **Vector** if you expect the output signal from this block to be the input signal for a Simulink Real-Time scope or some other block that requires vector input.

Scan clock source

Select **Internal** or **External** to identify the clock source for the frame scans.

Scan time

Enter the time (in seconds) between scans as the interval.

Frame time

Enter the interval (in seconds) during which the board will interrupt. The driver block evenly spaces the scans in the frame across the **Frame time** interval. If the **Frame time** interval is too short, you will receive a buffer overrun error at run time. For optimal results, experimentally increase the **Frame time** value and reiterate the process. Rebuild the model when you change this value.

The **Frame size**, **Scan time**, and **Frame time** parameters are not independent, but are related by

$$\text{Frametime} = \text{Framesize} \times \text{Scantime}.$$

After you specify two of the parameters, specify - 1 for the third parameter and the equation determines the third parameter.

Note: Because the Simulink Real-Time software uses this value to set parameters on the board, you cannot change the **Frame time** value at the MATLAB prompt.

Block is in an ISR

Select this check box if the block is in an interrupt service routine (ISR). Selecting this check box forces the block sample time to -1 , which enables the block to work in the ISR. If this check box is not selected, the block sample time is equal to the value of **Frame time**.

Slave board

If you have multiple boards configured in a master/slave combination, select this box for the slave boards only. Leave the box unchecked for the master board. (Note that a single board configuration is considered a master board.)

Note: In the model, set the priority of slave blocks higher than master blocks. Right-click the slave or master block and select **Properties**. In the dialog, enter a value in the **Priority** property. For example, if you have multiple slave blocks, you can enter values of 2 for the slave blocks and 3 for the master block, where a lower number indicates a higher priority.

Acquisition frequency

Enter the rate at which the high speed conversion clock runs. This is the clock used to acquire each scan in a frame. For example, with a PD2-MF-xx-333/16H board, the maximum clock is 333 kHz. At that rate, the second channel in a scan will be acquired 3 microseconds after the first one in every scan of the frame.

Specify - 1 to select the maximum rate available for the specified board.

DMA burst size

From the list, select either 32, 16, or 8. The DMA engine transfers data in packets of the burst size or less. Between each burst, a new bus arbitration cycle must complete. Better performance is achieved with higher **DMA burst size** values, with 32 being

highest. However, in some architectures and with some PCI bus adaptors, a **DMA burst size** of 32 might cause problems. For example, it might lock up the target computer when DMA is attempted. In these cases, reduce the **DMA burst size** value to 8, rebuild and rerun the real-time application. If the DMA works at 8, select 16 and try again.

PCI slot (-1:autosearch)

If only one board of this type is in the target computer, enter - 1 to locate the board.

If two or more boards of this type are in the target computer, enter the bus number and the PCI slot number of the board associated with this driver block. Use the format **[BusNumber,SlotNumber]**.

To determine the bus number and the PCI slot number, type:

```
tg = slrt;  
getPCIInfo(tg, 'installed')
```

More About

- “Specifying UEI Boards” on page 53-3

External Websites

- www.ueidaq.com

UEI PD2-MFS 16-Bit Series Analog Output (D/A)

PD2-MFS 16-Bit Series Analog Output block

Library

Simulink Real-Time Library for UEI

Scaling Input to Output

I/O Module Output	Block Input Data Type	Scaling
Volts	Double	1

Block Parameters

Board type

Select the specific board type from the list provided.

Channel vector

Enter a vector of numbers to specify the output channels 1 or 2. For example, to use the first and second analog output (D/A) channels, enter

```
[1 2]
```

The channel numbers can occur in arbitrary order. Number the channels beginning with 1 even if this board manufacturer numbers them beginning with 0.

Reset vector

The reset vector must be the same length as the channel vector. It contains values of 0 or 1. This parameter controls the behavior at model termination. A value of 1 causes the corresponding channel to be reset to the value specified in the initial value vector. A value of 0 causes the channel to remain at the last value attained while the model was running.

Initial value vector

The initial value vector must be the same length as the channel vector and should contain the initial voltage values for the output channels. The channels are set to these values between the time the model is downloaded and the time it is started.

Sample time

Enter the base sample time or a multiple of the base sample time (- 1 means sample time is inherited).

PCI slot (-1:autosearch)

If only one board of this type is in the target computer, enter - 1 to locate the board.

If two or more boards of this type are in the target computer, enter the bus number and the PCI slot number of the board associated with this driver block. Use the format **[BusNumber,SlotNumber]**.

To determine the bus number and the PCI slot number, type:

```
tg = slrt;  
getPCIInfo(tg, 'installed')
```

More About

- “Specifying UEI Boards” on page 53-3

External Websites

- www.ueidaq.com

UEI PD2-MFS 16-Bit Series Digital Input

PD2-MFS 16-Bit Series Digital Input block

Library

Simulink Real-Time Library for UEI

Scaling Input to Output

I/O Module Input	Block Output Data Type	Scaling
TTL	Double	TTL low = 0.0 TTL high = 1.0

Block Parameters

Board type

Select the specific board type from the list provided.

Channel vector

Enter a vector of numbers to specify the input channels. For example, to use the first and third digital input channels, enter

```
[1 3]
```

The channel numbers can occur in arbitrary order. Number the channels beginning with 1 even if this board manufacturer numbers them beginning with 0. The maximum allowable channel number is 16 except for the PD2-AO and PDXI-AO series. For those boards, the maximum channel number is 8.

Sample time

Enter the base sample time or a multiple of the base sample time (-1 means sample time is inherited).

PCI slot (-1:autosearch)

If only one board of this type is in the target computer, enter -1 to locate the board.

If two or more boards of this type are in the target computer, enter the bus number and the PCI slot number of the board associated with this driver block. Use the format **[BusNumber,SlotNumber]**.

To determine the bus number and the PCI slot number, type:

```
tg = slrt;  
getPCIInfo(tg, 'installed')
```

More About

- “Specifying UEI Boards” on page 53-3

External Websites

- www.ueidaq.com

UEI PD2-MFS 16-Bit Series Digital Output

PD2-MFS 16-Bit Series Digital Output

Library

Simulink Real-Time Library for UEI

Scaling Input to Output

I/O Module Output	Block Input Data Type	Scaling
TTL	Double	< 0.5 = TTL low > 0.5 = TTL high

Block Parameters

Board type

Select the specific board type from the list provided.

Channel vector

Enter a vector of numbers to specify the output channels. For example, to use the first and third digital output channels, enter

```
[1 3]
```

The channel numbers can occur in arbitrary order. Number the channels beginning with 1 even if this board manufacturer numbers them beginning with 0. The maximum allowable channel number is 16, except for the PD2-AO and PDXI-AO series. For those boards, the maximum channel number is 8.

Reset vector

The reset vector must be the same length as the channel vector. It contains values of 0 or 1. This parameter controls the behavior at model termination. A value of 1 causes the corresponding channel to be reset to the value specified in the initial value vector. A value of 0 causes the channel to remain at the last value attained while the model was running.

Initial value vector

The initial value vector must be the same length as the channel vector. It contains the initial values (0 or 1) for the output channels. The channels are set to these values between the time the model is downloaded and the time it is started.

Sample time

Enter the base sample time or a multiple of the base sample time (- 1 means sample time is inherited).

PCI slot (-1:autosearch)

If only one board of this type is in the target computer, enter - 1 to locate the board.

If two or more boards of this type are in the target computer, enter the bus number and the PCI slot number of the board associated with this driver block. Use the format [**BusNumber,SlotNumber**].

To determine the bus number and the PCI slot number, type:

```
tg = slrt;  
getPCIInfo(tg, 'installed')
```

More About

- “Specifying UEI Boards” on page 53-3

External Websites

- www.ueidaq.com

UEI PDXI-MF 12-Bit Series

Support for the UEI PDXI-MF 12-Bit Series I/O boards

Board Series

UEI PDXI-MF 12-Bit Series

General Board Series Description

The PDXI-MF 12-bit series contains I/O boards with 16 or 64 single or 8 or 32 differential analog input (A/D) channels (12-bit) with a maximum sample rate of 1.25 MHz or 3 MHz. The gain varies from 1 to 8 or 1 to 1000. The boards also have 2 analog output (D/A) channels (12-bit), 16 digital input, and 16 digital output lines. The Simulink Real-Time software does not support the counter/timers on these boards.

The Simulink Real-Time block library supports this series of boards with these driver blocks:

- UEI PDXI-MF 12-Bit Series Analog Input (A/D)
- UEI PDXI-MF 12-Bit Series Frame Analog Input
- UEI PDXI-MF 12-Bit Series Analog Output (D/A)
- UEI PDXI-MF 12-Bit Series Digital Input
- UEI PDXI-MF 12-Bit Series Digital Output

Board Characteristics

Board type	PDXI-MF-16-1M/12L
	PDXI-MF-16-1M/12H
	PDXI-MF-64-1M/12L
	PDXI-MF-64-1M/12H
	PDXI-MF-16-3M/12L
	PDXI-MF-16-3M/12H
	PDXI-MF-64-3M/12L
	PDXI-MF-64-3M/12H

Manufacturer	United Electronic Industries (UEI)
Bus type	CompactPCI, PXI
Access method	Memory mapped
Multiple block instance support	No
Multiple board support	Yes

More About

- “Specifying UEI Boards” on page 53-3

External Websites

- www.ueidaq.com

UEI PDXI-MF 12-Bit Series Analog Input (A/D)

PDXI-MF 12-Bit Series Analog Input block

Library

Simulink Real-Time Library for UEI

Scaling Input to Output

I/O Module Input	Block Output Data Type	Scaling
Volts	Double	1

Block Parameters

Board type

Select the specific board type from the list provided.

Channel vector

Enter a vector of numbers to specify the input channels. For example, use the first and third analog input (A/D) channels, enter

[1 3]

The channel numbers can occur in arbitrary order. Number the channels beginning with 1 even if this board manufacturer numbers them beginning with 0. The maximum allowable channel number is 4, 8, 16, or 64 depending on the board type.

Gain vector

Enter a vector of numbers to select the gains for each of the channels. Available gains vary depending on board type. MF PGL gains may be set to 1, 10, 100, or 1000. MF PGH gains may be set to 1, 2, 4, or 8. MF DG-option gains may be set to 1, 2, 5, or 10.

Mux settling time vector (slow bit)

This vector must be the same length as the channel vector. It contains values of 0 or 1. If 1, the corresponding channel has a longer settling time. This is useful when using a high gain such as 100 or 1000.

Range

Select the voltage range from the list provided. This applies to all channels.

Input coupling mode

From the list, select one from the following list of input coupling modes:

- Single Ended
- Differential

Refer to the UEI PowerDAQ documentation for input connections.

Sample time

Enter the base sample time or a multiple of the base sample time (- 1 means sample time is inherited).

PCI slot (-1:autosearch)

If only one board of this type is in the target computer, enter - 1 to locate the board.

If two or more boards of this type are in the target computer, enter the bus number and the PCI slot number of the board associated with this driver block. Use the format [**BusNumber,SlotNumber**].

To determine the bus number and the PCI slot number, type:

```
tg = slrt;  
getPCIInfo(tg, 'installed')
```

More About

- “Specifying UEI Boards” on page 53-3

External Websites

- www.ueidaq.com

UEI PDXI-MF 12-Bit Series Frame Analog Input

PDXI-MF 12-Bit Series Frame Analog Input block

Library

Simulink Real-Time Library for UEI

Scaling Input to Output

I/O Module Input	Block Output Data Type	Scaling
Volts	Double	1

Block Parameters

Board type

Select the specific board type from the list provided.

Channel vector

Enter a vector of numbers that make up one scan. For example, to read the first and fifth channels, enter

```
[1 5]
```

The channel numbers can occur in arbitrary order. Number the channels beginning with 1 even if this board manufacturer numbers them beginning with 0. The maximum allowable channel number is 4, 8, 16, or 64 depending on the board type.

Gain vector

Enter a vector of numbers to specify the gains for each of the channels in the scan.

Enter a single value to replicate the gain value across the channels in the scan.

Available gains vary depending on board type. Allowable values depend on the board type.

- L (Low level) boards — Specify the gain as one of 1, 10, 100, or 1000.
- H (High level) boards — Specify the gain as one of 1, 2, 4, or 8.
- DG-option boards — Specify the gain as one of 1, 2, 5, or 10.

Mux settling time vector (slow bit)

Enter a vector that is the same length as the channel vector. Each vector element must be a 0 or 1. If you specify 1, the corresponding channel has a longer settling time. To get a more accurate reading, you might want to specify a 1 for channels that have higher gains, such as 100 or 1000. Refer to the UEI PowerDAQ documentation for further information on the longer settling time. This time depends on the board type.

Caution With frame based acquisition, the additional time resulting from setting the **Mux settling time vector (slow bit)** might cause an acquisition overrun that the Simulink Real-Time software does not detect. For example, on a PD2-MF-xx-333/16H board, each acquisition takes 3 microseconds if the slow bit is 0. If the slow bit is 1, that same acquisition takes more than 10 microseconds. With the Simulink Real-Time software, the scan is performed at the maximum rate for a given board. This means that the slow acquisition takes a multiple of 3 microsecond ticks. For a PD2-MF-xx-333/16H board, this becomes 12 microseconds.

For example, assume that N scans of the channel vector compose a frame of data. Assume also that you have a PD2-MF-xx-333/16H board with a **Channel vector** value of [1 2 3 4] and a **Mux settling time vector (slow bit)** value of [0 1 0 1]. For the PD2-MF-xx-333/16H board, two of the acquisition delays are 3 microseconds, and two are 12 microseconds. With a **Frame time** value of 0.001 second, if N is greater than 38, the data will not be acceptable. If you set the slow bits to 0, N can have a value of up to 83. The software detects the limit at $N = 83$, but is not aware of the extra board dependent delay.

Range

From the list, select one of the following voltage ranges. The value you select applies to all channels.

- +-10 Volts
- +-5 Volts
- 0-10 Volts
- 0-5 Volts

Input coupling mode

From the list, select one from the following list of input coupling modes:

- Single Ended
- Differential

Refer to the UEI PowerDAQ documentation for input connections.

Frame size

Enter the number of samples per channel to return as a frame of data. Due to physical constraints in the I/O module, the total number of samples in a frame of data cannot exceed 512. The relationship between the number of samples, frame size, and number of channels is

total number of samples = FrameSize x nChannels

For example, if you specify two channels, the frame size must be less than or equal to 256.

Output format

From the list, select either **Frame** or **Vector**.

- **Frame** — Select **Frame** if you expect the output signal from this block to be the input signal for a block that requires a frame. For example, a **Signal Processing** block.
- **Vector** — Select **Vector** if you expect the output signal from this block to be the input signal for a **Simulink Real-Time** scope or some other block that requires vector input.

Scan clock source

Select **Internal** or **External** to identify the clock source for the frame scans.

Scan time

Enter the time (in seconds) between scans as the interval.

Frame time

Enter the interval (in seconds) during which the board will interrupt. The driver block evenly spaces the scans in the frame across the **Frame time** interval. If the **Frame time** interval is too short, you will receive a buffer overrun error at run time. For optimal results, experimentally increase the **Frame time** value and reiterate the process. Rebuild the model when you change this value.

The **Frame size**, **Scan time**, and **Frame time** parameters are not independent, but are related by

$$\text{Frametime} = \text{Framesize} \times \text{Scantime}.$$

After you specify two of the parameters, specify -1 for the third parameter and the equation determines the third parameter.

Note: Because the Simulink Real-Time software uses this value to set parameters on the board, you cannot change the **Frame time** value at the MATLAB prompt.

Block is in an ISR

Select this check box if the block is in an interrupt service routine (ISR). Selecting this check box forces the block sample time to -1 , which enables the block to work in the ISR. If this check box is not selected, the block sample time is equal to the value of **Frame time**.

Slave board

If you have multiple boards configured in a master/slave combination, select this box for the slave boards only. Leave the box unchecked for the master board. (Note that a single board configuration is considered a master board.)

Note: In the model, set the priority of slave blocks higher than master blocks. Right-click the slave or master block and select **Properties**. In the dialog, enter a value in the **Priority** property. For example, if you have multiple slave blocks, you can enter values of 2 for the slave blocks and 3 for the master block, where a lower number indicates a higher priority.

Acquisition frequency

Enter the rate at which the high speed conversion clock runs. This is the clock used to acquire each scan in a frame. For example, with a PD2-MF-xx-333/16H board, the maximum clock is 333 kHz. At that rate, the second channel in a scan will be acquired 3 microseconds after the first one in every scan of the frame.

Specify -1 to select the maximum rate available for the specified board.

DMA burst size

From the list, select either 32, 16, or 8. The DMA engine transfers data in packets of the burst size or less. Between each burst, a new bus arbitration cycle must complete. Better performance is achieved with higher **DMA burst size** values, with 32 being

highest. However, in some architectures and with some PCI bus adaptors, a **DMA burst size** of 32 might cause problems. For example, it might lock up the target computer when DMA is attempted. In these cases, reduce the **DMA burst size** value to 8, rebuild and rerun the real-time application. If the DMA works at 8, select 16 and try again.

PCI slot (-1:autosearch)

If only one board of this type is in the target computer, enter - 1 to locate the board.

If two or more boards of this type are in the target computer, enter the bus number and the PCI slot number of the board associated with this driver block. Use the format **[BusNumber,SlotNumber]**.

To determine the bus number and the PCI slot number, type:

```
tg = slrt;  
getPCIInfo(tg, 'installed')
```

More About

- “Specifying UEI Boards” on page 53-3

External Websites

- www.ueidaq.com

UEI PDXI-MF 12-Bit Series Analog Output (D/A)

PDXI-MF 12-Bit Series Analog Output block

Library

Simulink Real-Time Library for UEI

Scaling Input to Output

I/O Module Output	Block Input Data Type	Scaling
Volts	Double	1

Block Parameters

Board type

Select the specific board type from the list provided.

Channel vector

Enter a vector of numbers to specify the output channels 1 or 2. For example, to use the first and second analog output (D/A) channels, enter

```
[1 2]
```

The channel numbers can occur in arbitrary order. Number the channels beginning with 1 even if this board manufacturer numbers them beginning with 0.

Reset vector

The reset vector must be the same length as the channel vector. It contains values of 0 or 1. This parameter controls the behavior at model termination. A value of 1 causes the corresponding channel to be reset to the value specified in the initial value vector. A value of 0 causes the channel to remain at the last value attained while the model was running.

Initial value vector

The initial value vector must be the same length as the channel vector and should contain the initial voltage values for the output channels. The channels are set to these values between the time the model is downloaded and the time it is started.

Sample time

Enter the base sample time or a multiple of the base sample time (- 1 means sample time is inherited).

PCI slot (-1:autosearch)

If only one board of this type is in the target computer, enter - 1 to locate the board.

If two or more boards of this type are in the target computer, enter the bus number and the PCI slot number of the board associated with this driver block. Use the format **[BusNumber,SlotNumber]**.

To determine the bus number and the PCI slot number, type:

```
tg = slrt;  
getPCIInfo(tg, 'installed')
```

More About

- “Specifying UEI Boards” on page 53-3

External Websites

- www.ueidaq.com

UEI PDXI-MF 12-Bit Series Digital Input

PDXI-MF 12-Bit Series Digital Input block

Library

Simulink Real-Time Library for UEI

Scaling Input to Output

I/O Module Input	Block Output Data Type	Scaling
TTL	Double	TTL low = 0.0 TTL high = 1.0

Block Parameters

Board type

Select the specific board type from the list provided.

Channel vector

Enter a vector of numbers to specify the input channels. For example, to use the first and third digital input channels, enter

```
[1 3]
```

The channel numbers can occur in arbitrary order. Number the channels beginning with 1 even if this board manufacturer numbers them beginning with 0. The maximum allowable channel number is 16 except for the PD2-AO and PDXI-AO series. For those boards, the maximum channel number is 8.

Sample time

Enter the base sample time or a multiple of the base sample time (-1 means sample time is inherited).

PCI slot (-1:autosearch)

If only one board of this type is in the target computer, enter -1 to locate the board.

If two or more boards of this type are in the target computer, enter the bus number and the PCI slot number of the board associated with this driver block. Use the format **[BusNumber,SlotNumber]**.

To determine the bus number and the PCI slot number, type:

```
tg = slrt;  
getPCIInfo(tg, 'installed')
```

More About

- “Specifying UEI Boards” on page 53-3

External Websites

- www.ueidaq.com

UEI PDXI-MF 12-Bit Series Digital Output

PDXI-MF 12-Bit Series Digital Output block

Library

Simulink Real-Time Library for UEI

Scaling Input to Output

I/O Module Output	Block Input Data Type	Scaling
TTL	Double	< 0.5 = TTL low > 0.5 = TTL high

Block Parameters

Board type

Select the specific board type from the list provided.

Channel vector

Enter a vector of numbers to specify the output channels. For example, to use the first and third digital output channels, enter

```
[1 3]
```

The channel numbers can occur in arbitrary order. Number the channels beginning with 1 even if this board manufacturer numbers them beginning with 0. The maximum allowable channel number is 16, except for the PD2-AO and PDXI-AO series. For those boards, the maximum channel number is 8.

Reset vector

The reset vector must be the same length as the channel vector. It contains values of 0 or 1. This parameter controls the behavior at model termination. A value of 1 causes the corresponding channel to be reset to the value specified in the initial value vector. A value of 0 causes the channel to remain at the last value attained while the model was running.

Initial value vector

The initial value vector must be the same length as the channel vector. It contains the initial values (0 or 1) for the output channels. The channels are set to these values between the time the model is downloaded and the time it is started.

Sample time

Enter the base sample time or a multiple of the base sample time (- 1 means sample time is inherited).

PCI slot (-1:autosearch)

If only one board of this type is in the target computer, enter - 1 to locate the board.

If two or more boards of this type are in the target computer, enter the bus number and the PCI slot number of the board associated with this driver block. Use the format [**BusNumber,SlotNumber**].

To determine the bus number and the PCI slot number, type:

```
tg = slrt;  
getPCIInfo(tg, 'installed')
```

More About

- “Specifying UEI Boards” on page 53-3

External Websites

- www.ueidaq.com

UEI PDXI-MF 14-Bit Series

Support for the UEI PDXI-MF 14-Bit Series I/O boards

Board Series

UEI PDXI-MF 14-Bit Series

General Board Series Description

The PDXI-MF 14-bit series contains I/O boards with 16 or 64 single or 8 or 32 differential analog input (A/D) channels (14-bit). The boards also have 2 analog output (D/A) channels (12-bit), 16 digital input, and 16 digital output lines. the Simulink Real-Time software does not support the counter/timers on these boards.

The Simulink Real-Time block library supports this series of boards with these driver blocks:

- UEI PDXI-MF 14-Bit Series Analog Input (A/D)
- UEI PDXI-MF 14-Bit Series Frame Analog Input
- UEI PDXI-MF 14-Bit Series Analog Output (D/A)
- UEI PDXI-MF 14-Bit Series Digital Input
- UEI PDXI-MF 14-Bit Series Digital Output

Board Characteristics

Board type	PDXI-MF-16-400/14L PDXI-MF-16-400/14H PDXI-MF-64-400/14L PDXI-MF-64-400/14H PDXI-MF-16-2M/14H PDXI-MF-64-2M/14H
Manufacturer	United Electronic Industries (UEI)
Bus type	CompactPCI, PXI

Access method	Memory mapped
Multiple block instance support	No
Multiple board support	Yes

More About

- “Specifying UEI Boards” on page 53-3

External Websites

- www.ueidaq.com

UEI PDXI-MF 14-Bit Series Analog Input (A/D)

PDXI-MF 14-Bit Series Analog Input block

Library

Simulink Real-Time Library for UEI

Scaling Input to Output

I/O Module Input	Block Output Data Type	Scaling
Volts	Double	1

Block Parameters

Board type

Select the specific board type from the list provided.

Channel vector

Enter a vector of numbers to specify the input channels. For example, use the first and third analog input (A/D) channels, enter

```
[1 3]
```

The channel numbers can occur in arbitrary order. Number the channels beginning with 1 even if this board manufacturer numbers them beginning with 0. The maximum allowable channel number is 4, 8, 16, or 64 depending on the board type.

Gain vector

Enter a vector of numbers to select the gains for each of the channels. Available gains vary depending on board type. MF PGL gains may be set to 1, 10, 100, or 1000. MF PGH gains may be set to 1, 2, 4, or 8. MF DG-option gains may be set to 1, 2, 5, or 10.

Mux settling time vector (slow bit)

This vector must be the same length as the channel vector. It contains values of 0 or 1. If 1, the corresponding channel has a longer settling time. This is useful when using a high gain such as 100 or 1000.

Range

Select the voltage range from the list provided. This applies to all channels.

Input coupling mode

From the list, select one from the following list of input coupling modes:

- Single Ended
- Differential

Refer to the UEI PowerDAQ documentation for input connections.

Sample time

Enter the base sample time or a multiple of the base sample time (- 1 means sample time is inherited).

PCI slot (-1:autosearch)

If only one board of this type is in the target computer, enter - 1 to locate the board.

If two or more boards of this type are in the target computer, enter the bus number and the PCI slot number of the board associated with this driver block. Use the format [**BusNumber,SlotNumber**].

To determine the bus number and the PCI slot number, type:

```
tg = slrt;  
getPCIInfo(tg, 'installed')
```

More About

- “Specifying UEI Boards” on page 53-3

External Websites

- www.ueidaq.com

UEI PDXI-MF 14-Bit Series Frame Analog Input

PDXI-MF 14-Bit Series Frame Analog Input block

Library

Simulink Real-Time Library for UEI

Scaling Input to Output

I/O Module Input	Block Output Data Type	Scaling
Volts	Double	1

Block Parameters

Board type

Select the specific board type from the list provided.

Channel vector

Enter a vector of numbers that make up one scan. For example, to read the first and fifth channels, enter

```
[1 5]
```

The channel numbers can occur in arbitrary order. Number the channels beginning with 1 even if this board manufacturer numbers them beginning with 0. The maximum allowable channel number is 4, 8, 16, or 64 depending on the board type.

Gain vector

Enter a vector of numbers to specify the gains for each of the channels in the scan.

Enter a single value to replicate the gain value across the channels in the scan.

Available gains vary depending on board type. Allowable values depend on the board type.

- L (Low level) boards — Specify the gain as one of 1, 10, 100, or 1000.
- H (High level) boards — Specify the gain as one of 1, 2, 4, or 8.
- DG-option boards — Specify the gain as one of 1, 2, 5, or 10.

Mux settling time vector (slow bit)

Enter a vector that is the same length as the channel vector. Each vector element must be a 0 or 1. If you specify 1, the corresponding channel has a longer settling time. To get a more accurate reading, you might want to specify a 1 for channels that have higher gains, such as 100 or 1000. Refer to the UEI PowerDAQ documentation for further information on the longer settling time. This time depends on the board type.

Caution With frame based acquisition, the additional time resulting from setting the **Mux settling time vector (slow bit)** might cause an acquisition overrun that the Simulink Real-Time software does not detect. For example, on a PD2-MF-xx-333/16H board, each acquisition takes 3 microseconds if the slow bit is 0. If the slow bit is 1, that same acquisition takes more than 10 microseconds. With the Simulink Real-Time software, the scan is performed at the maximum rate for a given board. This means that the slow acquisition takes a multiple of 3 microsecond ticks. For a PD2-MF-xx-333/16H board, this becomes 12 microseconds.

For example, assume that N scans of the channel vector compose a frame of data. Assume also that you have a PD2-MF-xx-333/16H board with a **Channel vector** value of [1 2 3 4] and a **Mux settling time vector (slow bit)** value of [0 1 0 1]. For the PD2-MF-xx-333/16H board, two of the acquisition delays are 3 microseconds, and two are 12 microseconds. With a **Frame time** value of 0.001 second, if N is greater than 38, the data will not be acceptable. If you set the slow bits to 0, N can have a value of up to 83. The software detects the limit at $N = 83$, but is not aware of the extra board dependent delay.

Range

From the list, select one of the following voltage ranges. The value you select applies to all channels.

- +-10 Volts
- +-5 Volts
- 0-10 Volts
- 0-5 Volts

Input coupling mode

From the list, select one from the following list of input coupling modes:

- Single Ended
- Differential

Refer to the UEI PowerDAQ documentation for input connections.

Frame size

Enter the number of samples per channel to return as a frame of data. Due to physical constraints in the I/O module, the total number of samples in a frame of data cannot exceed 512. The relationship between the number of samples, frame size, and number of channels is

$$\text{total number of samples} = \text{FrameSize} \times \text{nChannels}$$

For example, if you specify two channels, the frame size must be less than or equal to 256.

Output format

From the list, select either **Frame** or **Vector**.

- **Frame** — Select **Frame** if you expect the output signal from this block to be the input signal for a block that requires a frame. For example, a Signal Processing block.
- **Vector** — Select **Vector** if you expect the output signal from this block to be the input signal for a Simulink Real-Time scope or some other block that requires vector input.

Scan clock source

Select **Internal** or **External** to identify the clock source for the frame scans.

Scan time

Enter the time (in seconds) between scans as the interval.

Frame time

Enter the interval (in seconds) during which the board will interrupt. The driver block evenly spaces the scans in the frame across the **Frame time** interval. If the **Frame time** interval is too short, you will receive a buffer overrun error at run time. For optimal results, experimentally increase the **Frame time** value and reiterate the process. Rebuild the model when you change this value.

The **Frame size**, **Scan time**, and **Frame time** parameters are not independent, but are related by

$$\text{Frametime} = \text{Framesize} \times \text{Scantime}.$$

After you specify two of the parameters, specify - 1 for the third parameter and the equation determines the third parameter.

Note: Because the Simulink Real-Time software uses this value to set parameters on the board, you cannot change the **Frame time** value at the MATLAB prompt.

Block is in an ISR

Select this check box if the block is in an interrupt service routine (ISR). Selecting this check box forces the block sample time to -1, which enables the block to work in the ISR. If this check box is not selected, the block sample time is equal to the value of **Frame time**.

Slave board

If you have multiple boards configured in a master/slave combination, select this box for the slave boards only. Leave the box unchecked for the master board. (Note that a single board configuration is considered a master board.)

Note: In the model, set the priority of slave blocks higher than master blocks. Right-click the slave or master block and select **Properties**. In the dialog, enter a value in the **Priority** property. For example, if you have multiple slave blocks, you can enter values of 2 for the slave blocks and 3 for the master block, where a lower number indicates a higher priority.

Acquisition frequency

Enter the rate at which the high speed conversion clock runs. This is the clock used to acquire each scan in a frame. For example, with a PD2-MF-xx-333/16H board, the maximum clock is 333 kHz. At that rate, the second channel in a scan will be acquired 3 microseconds after the first one in every scan of the frame.

Specify - 1 to select the maximum rate available for the specified board.

DMA burst size

From the list, select either 32, 16, or 8. The DMA engine transfers data in packets of the burst size or less. Between each burst, a new bus arbitration cycle must complete. Better performance is achieved with higher **DMA burst size** values, with 32 being

highest. However, in some architectures and with some PCI bus adaptors, a **DMA burst size** of 32 might cause problems. For example, it might lock up the target computer when DMA is attempted. In these cases, reduce the **DMA burst size** value to 8, rebuild and rerun the real-time application. If the DMA works at 8, select 16 and try again.

PCI slot (-1:autosearch)

If only one board of this type is in the target computer, enter - 1 to locate the board.

If two or more boards of this type are in the target computer, enter the bus number and the PCI slot number of the board associated with this driver block. Use the format **[BusNumber,SlotNumber]**.

To determine the bus number and the PCI slot number, type:

```
tg = slrt;  
getPCIInfo(tg, 'installed')
```

More About

- “Specifying UEI Boards” on page 53-3

External Websites

- www.ueidaq.com

UEI PDXI-MF 14-Bit Series Analog Output (D/A)

PDXI-MF 14-Bit Series Analog Output block

Library

Simulink Real-Time Library for UEI

Scaling Input to Output

I/O Module Output	Block Input Data Type	Scaling
Volts	Double	1

Block Parameters

Board type

Select the specific board type from the list provided.

Channel vector

Enter a vector of numbers to specify the output channels 1 or 2. For example, to use the first and second analog output (D/A) channels, enter

```
[1 2]
```

The channel numbers can occur in arbitrary order. Number the channels beginning with 1 even if this board manufacturer numbers them beginning with 0.

Reset vector

The reset vector must be the same length as the channel vector. It contains values of 0 or 1. This parameter controls the behavior at model termination. A value of 1 causes the corresponding channel to be reset to the value specified in the initial value vector. A value of 0 causes the channel to remain at the last value attained while the model was running.

Initial value vector

The initial value vector must be the same length as the channel vector and should contain the initial voltage values for the output channels. The channels are set to these values between the time the model is downloaded and the time it is started.

Sample time

Enter the base sample time or a multiple of the base sample time (- 1 means sample time is inherited).

PCI slot (-1:autosearch)

If only one board of this type is in the target computer, enter - 1 to locate the board.

If two or more boards of this type are in the target computer, enter the bus number and the PCI slot number of the board associated with this driver block. Use the format **[BusNumber,SlotNumber]**.

To determine the bus number and the PCI slot number, type:

```
tg = slrt;  
getPCIInfo(tg, 'installed')
```

More About

- “Specifying UEI Boards” on page 53-3

External Websites

- www.ueidaq.com

UEI PDXI-MF 14-Bit Series Digital Input

PDXI-MF 14-Bit Series Digital Input block

Library

Simulink Real-Time Library for UEI

Scaling Input to Output

I/O Module Input	Block Output Data Type	Scaling
TTL	Double	TTL low = 0.0 TTL high = 1.0

Block Parameters

Board type

Select the specific board type from the list provided.

Channel vector

Enter a vector of numbers to specify the input channels. For example, to use the first and third digital input channels, enter

```
[1 3]
```

The channel numbers can occur in arbitrary order. Number the channels beginning with 1 even if this board manufacturer numbers them beginning with 0. The maximum allowable channel number is 16 except for the PD2-AO and PDXI-AO series. For those boards, the maximum channel number is 8.

Sample time

Enter the base sample time or a multiple of the base sample time (-1 means sample time is inherited).

PCI slot (-1:autosearch)

If only one board of this type is in the target computer, enter -1 to locate the board.

If two or more boards of this type are in the target computer, enter the bus number and the PCI slot number of the board associated with this driver block. Use the format **[BusNumber,SlotNumber]**.

To determine the bus number and the PCI slot number, type:

```
tg = slrt;  
getPCIInfo(tg, 'installed')
```

More About

- “Specifying UEI Boards” on page 53-3

External Websites

- www.ueidaq.com

UEI PDXI-MF 14-Bit Series Digital Output

PDXI-MF 14-Bit Series Digital Output block

Library

Simulink Real-Time Library for UEI

Scaling Input to Output

I/O Module Output	Block Input Data Type	Scaling
TTL	Double	< 0.5 = TTL low > 0.5 = TTL high

Block Parameters

Board type

Select the specific board type from the list provided.

Channel vector

Enter a vector of numbers to specify the output channels. For example, to use the first and third digital output channels, enter

```
[1 3]
```

The channel numbers can occur in arbitrary order. Number the channels beginning with 1 even if this board manufacturer numbers them beginning with 0. The maximum allowable channel number is 16, except for the PD2-AO and PDXI-AO series. For those boards, the maximum channel number is 8.

Reset vector

The reset vector must be the same length as the channel vector. It contains values of 0 or 1. This parameter controls the behavior at model termination. A value of 1 causes the corresponding channel to be reset to the value specified in the initial value vector. A value of 0 causes the channel to remain at the last value attained while the model was running.

Initial value vector

The initial value vector must be the same length as the channel vector. It contains the initial values (0 or 1) for the output channels. The channels are set to these values between the time the model is downloaded and the time it is started.

Sample time

Enter the base sample time or a multiple of the base sample time (- 1 means sample time is inherited).

PCI slot (-1:autosearch)

If only one board of this type is in the target computer, enter - 1 to locate the board.

If two or more boards of this type are in the target computer, enter the bus number and the PCI slot number of the board associated with this driver block. Use the format **[BusNumber,SlotNumber]**.

To determine the bus number and the PCI slot number, type:

```
tg = slrt;  
getPCIInfo(tg, 'installed')
```

More About

- “Specifying UEI Boards” on page 53-3

External Websites

- www.ueidaq.com

UEI PDXI-MF 16-Bit Series

Support for the UEI PDXI-MF 16-Bit Series I/O boards

Board Series

UEI PDXI-MF 16-Bit Series

General Board Series Description

The PDXI-MF 16-bit series contains I/O boards with 16 or 64 single or 8 or 32 differential analog input (A/D) channels (16-bit). The boards also have 2 analog output (D/A) channels (12-bit), 16 digital input, and 16 digital output lines. The Simulink Real-Time software does not support the counter/timers on these boards.

The Simulink Real-Time block library supports this series of boards with these driver blocks:

- UEI PDXI-MF 16-Bit Series Analog Input (A/D)
- UEI PDXI-MF 16-Bit Series Frame Analog Input
- UEI PDXI-MF 16-Bit Series Analog Output (D/A)
- UEI PDXI-MF 16-Bit Series Digital Input
- UEI PDXI-MF 16-Bit Series Digital Output

Board Characteristics

Board type	PDXI-MF-16-333/16L PDXI-MF-16-333/16H PDXI-MF-64-333/16L PDXI-MF-64-333/16H PDXI-MF-16-500/16L PDXI-MF-16-500/16H PDXI-MF-64-500/16L PDXI-MF-64-500/16H
------------	--

Manufacturer	United Electronic Industries (UEI)
Bus type	CompactPCI, PXI
Access method	Memory mapped
Multiple block instance support	No
Multiple board support	Yes

More About

- “Specifying UEI Boards” on page 53-3

External Websites

- www.ueidaq.com

UEI PDXI-MF 16-Bit Series Analog Input (A/D)

PDXI-MF 16-Bit Series Analog Input block

Library

Simulink Real-Time Library for UEI

Scaling Input to Output

I/O Module Input	Block Output Data Type	Scaling
Volts	Double	1

Block Parameters

Board type

Select the specific board type from the list provided.

Channel vector

Enter a vector of numbers to specify the input channels. For example, use the first and third analog input (A/D) channels, enter

[1 3]

The channel numbers can occur in arbitrary order. Number the channels beginning with 1 even if this board manufacturer numbers them beginning with 0. The maximum allowable channel number is 4, 8, 16, or 64 depending on the board type.

Gain vector

Enter a vector of numbers to select the gains for each of the channels. Available gains vary depending on board type. MF PGL gains may be set to 1, 10, 100, or 1000. MF PGH gains may be set to 1, 2, 4, or 8. MF DG-option gains may be set to 1, 2, 5, or 10.

Mux settling time vector (slow bit)

This vector must be the same length as the channel vector. It contains values of 0 or 1. If 1, the corresponding channel has a longer settling time. This is useful when using a high gain such as 100 or 1000.

Range

Select the voltage range from the list provided. This applies to all channels.

Input coupling mode

From the list, select one from the following list of input coupling modes:

- Single Ended
- Differential

Refer to the UEI PowerDAQ documentation for input connections.

Sample time

Enter the base sample time or a multiple of the base sample time (- 1 means sample time is inherited).

PCI slot (-1:autosearch)

If only one board of this type is in the target computer, enter - 1 to locate the board.

If two or more boards of this type are in the target computer, enter the bus number and the PCI slot number of the board associated with this driver block. Use the format [**BusNumber,SlotNumber**].

To determine the bus number and the PCI slot number, type:

```
tg = slrt;  
getPCIInfo(tg, 'installed')
```

More About

- “Specifying UEI Boards” on page 53-3

External Websites

- www.ueidaq.com

UEI PDXI-MF 16-Bit Series Frame Analog Input

PDXI-MF 16-Bit Series Frame Analog Input block

Library

Simulink Real-Time Library for UEI

Scaling Input to Output

I/O Module Input	Block Output Data Type	Scaling
Volts	Double	1

Block Parameters

Board type

Select the specific board type from the list provided.

Channel vector

Enter a vector of numbers that make up one scan. For example, to read the first and fifth channels, enter

```
[1 5]
```

The channel numbers can occur in arbitrary order. Number the channels beginning with 1 even if this board manufacturer numbers them beginning with 0. The maximum allowable channel number is 4, 8, 16, or 64 depending on the board type.

Gain vector

Enter a vector of numbers to specify the gains for each of the channels in the scan.

Enter a single value to replicate the gain value across the channels in the scan.

Available gains vary depending on board type. Allowable values depend on the board type.

- L (Low level) boards — Specify the gain as one of 1, 10, 100, or 1000.
- H (High level) boards — Specify the gain as one of 1, 2, 4, or 8.
- DG-option boards — Specify the gain as one of 1, 2, 5, or 10.

Mux settling time vector (slow bit)

Enter a vector that is the same length as the channel vector. Each vector element must be a 0 or 1. If you specify 1, the corresponding channel has a longer settling time. To get a more accurate reading, you might want to specify a 1 for channels that have higher gains, such as 100 or 1000. Refer to the UEI PowerDAQ documentation for further information on the longer settling time. This time depends on the board type.

Caution With frame based acquisition, the additional time resulting from setting the **Mux settling time vector (slow bit)** might cause an acquisition overrun that the Simulink Real-Time software does not detect. For example, on a PD2-MF-xx-333/16H board, each acquisition takes 3 microseconds if the slow bit is 0. If the slow bit is 1, that same acquisition takes more than 10 microseconds. With the Simulink Real-Time software, the scan is performed at the maximum rate for a given board. This means that the slow acquisition takes a multiple of 3 microsecond ticks. For a PD2-MF-xx-333/16H board, this becomes 12 microseconds.

For example, assume that N scans of the channel vector compose a frame of data. Assume also that you have a PD2-MF-xx-333/16H board with a **Channel vector** value of [1 2 3 4] and a **Mux settling time vector (slow bit)** value of [0 1 0 1]. For the PD2-MF-xx-333/16H board, two of the acquisition delays are 3 microseconds, and two are 12 microseconds. With a **Frame time** value of 0.001 second, if N is greater than 38, the data will not be acceptable. If you set the slow bits to 0, N can have a value of up to 83. The software detects the limit at $N = 83$, but is not aware of the extra board dependent delay.

Range

From the list, select one of the following voltage ranges. The value you select applies to all channels.

- +-10 Volts
- +-5 Volts
- 0-10 Volts
- 0-5 Volts

Input coupling mode

From the list, select one from the following list of input coupling modes:

- Single Ended
- Differential

Refer to the UEI PowerDAQ documentation for input connections.

Frame size

Enter the number of samples per channel to return as a frame of data. Due to physical constraints in the I/O module, the total number of samples in a frame of data cannot exceed 512. The relationship between the number of samples, frame size, and number of channels is

total number of samples = FrameSize x nChannels

For example, if you specify two channels, the frame size must be less than or equal to 256.

Output format

From the list, select either **Frame** or **Vector**.

- **Frame** — Select **Frame** if you expect the output signal from this block to be the input signal for a block that requires a frame. For example, a **Signal Processing** block.
- **Vector** — Select **Vector** if you expect the output signal from this block to be the input signal for a **Simulink Real-Time scope** or some other block that requires vector input.

Scan clock source

Select **Internal** or **External** to identify the clock source for the frame scans.

Scan time

Enter the time (in seconds) between scans as the interval.

Frame time

Enter the interval (in seconds) during which the board will interrupt. The driver block evenly spaces the scans in the frame across the **Frame time** interval. If the **Frame time** interval is too short, you will receive a buffer overrun error at run time. For optimal results, experimentally increase the **Frame time** value and reiterate the process. Rebuild the model when you change this value.

The **Frame size**, **Scan time**, and **Frame time** parameters are not independent, but are related by

$$\text{Frametime} = \text{Framesize} \times \text{Scantime}.$$

After you specify two of the parameters, specify -1 for the third parameter and the equation determines the third parameter.

Note: Because the Simulink Real-Time software uses this value to set parameters on the board, you cannot change the **Frame time** value at the MATLAB prompt.

Block is in an ISR

Select this check box if the block is in an interrupt service routine (ISR). Selecting this check box forces the block sample time to -1 , which enables the block to work in the ISR. If this check box is not selected, the block sample time is equal to the value of **Frame time**.

Slave board

If you have multiple boards configured in a master/slave combination, select this box for the slave boards only. Leave the box unchecked for the master board. (Note that a single board configuration is considered a master board.)

Note: In the model, set the priority of slave blocks higher than master blocks. Right-click the slave or master block and select **Properties**. In the dialog, enter a value in the **Priority** property. For example, if you have multiple slave blocks, you can enter values of 2 for the slave blocks and 3 for the master block, where a lower number indicates a higher priority.

Acquisition frequency

Enter the rate at which the high speed conversion clock runs. This is the clock used to acquire each scan in a frame. For example, with a PD2-MF-xx-333/16H board, the maximum clock is 333 kHz. At that rate, the second channel in a scan will be acquired 3 microseconds after the first one in every scan of the frame.

Specify -1 to select the maximum rate available for the specified board.

DMA burst size

From the list, select either 32, 16, or 8. The DMA engine transfers data in packets of the burst size or less. Between each burst, a new bus arbitration cycle must complete. Better performance is achieved with higher **DMA burst size** values, with 32 being

highest. However, in some architectures and with some PCI bus adaptors, a **DMA burst size** of 32 might cause problems. For example, it might lock up the target computer when DMA is attempted. In these cases, reduce the **DMA burst size** value to 8, rebuild and rerun the real-time application. If the DMA works at 8, select 16 and try again.

PCI slot (-1:autosearch)

If only one board of this type is in the target computer, enter - 1 to locate the board.

If two or more boards of this type are in the target computer, enter the bus number and the PCI slot number of the board associated with this driver block. Use the format **[BusNumber,SlotNumber]**.

To determine the bus number and the PCI slot number, type:

```
tg = slrt;  
getPCIInfo(tg, 'installed')
```

More About

- “Specifying UEI Boards” on page 53-3

External Websites

- www.ueidaq.com

UEI PDXI-MF 16-Bit Series Analog Output (D/A)

PDXI-MF 16-Bit Series Analog Output block

Library

Simulink Real-Time Library for UEI

Scaling Input to Output

I/O Module Output	Block Input Data Type	Scaling
Volts	Double	1

Block Parameters

Board type

Select the specific board type from the list provided.

Channel vector

Enter a vector of numbers to specify the output channels 1 or 2. For example, to use the first and second analog output (D/A) channels, enter

```
[1 2]
```

The channel numbers can occur in arbitrary order. Number the channels beginning with 1 even if this board manufacturer numbers them beginning with 0.

Reset vector

The reset vector must be the same length as the channel vector. It contains values of 0 or 1. This parameter controls the behavior at model termination. A value of 1 causes the corresponding channel to be reset to the value specified in the initial value vector. A value of 0 causes the channel to remain at the last value attained while the model was running.

Initial value vector

The initial value vector must be the same length as the channel vector and should contain the initial voltage values for the output channels. The channels are set to these values between the time the model is downloaded and the time it is started.

Sample time

Enter the base sample time or a multiple of the base sample time (- 1 means sample time is inherited).

PCI slot (-1:autosearch)

If only one board of this type is in the target computer, enter - 1 to locate the board.

If two or more boards of this type are in the target computer, enter the bus number and the PCI slot number of the board associated with this driver block. Use the format **[BusNumber,SlotNumber]**.

To determine the bus number and the PCI slot number, type:

```
tg = slrt;  
getPCIInfo(tg, 'installed')
```

More About

- “Specifying UEI Boards” on page 53-3

External Websites

- www.ueidaq.com

UEI PDXI-MF 16-Bit Series Digital Input

PDXI-MF 16-Bit Series Digital Input block

Library

Simulink Real-Time Library for UEI

Scaling Input to Output

I/O Module Input	Block Output Data Type	Scaling
TTL	Double	TTL low = 0.0 TTL high = 1.0

Block Parameters

Board type

Select the specific board type from the list provided.

Channel vector

Enter a vector of numbers to specify the input channels. For example, to use the first and third digital input channels, enter

```
[1 3]
```

The channel numbers can occur in arbitrary order. Number the channels beginning with 1 even if this board manufacturer numbers them beginning with 0. The maximum allowable channel number is 16 except for the PD2-AO and PDXI-AO series. For those boards, the maximum channel number is 8.

Sample time

Enter the base sample time or a multiple of the base sample time (-1 means sample time is inherited).

PCI slot (-1:autosearch)

If only one board of this type is in the target computer, enter -1 to locate the board.

If two or more boards of this type are in the target computer, enter the bus number and the PCI slot number of the board associated with this driver block. Use the format **[BusNumber,SlotNumber]**.

To determine the bus number and the PCI slot number, type:

```
tg = slrt;  
getPCIInfo(tg, 'installed')
```

More About

- “Specifying UEI Boards” on page 53-3

External Websites

- www.ueidaq.com

UEI PDXI-MF 16-Bit Series Digital Output

PDXI-MF 16-Bit Series Digital Output block

Library

Simulink Real-Time Library for UEI

Scaling Input to Output

I/O Module Output	Block Input Data Type	Scaling
TTL	Double	< 0.5 = TTL low > 0.5 = TTL high

Block Parameters

Board type

Select the specific board type from the list provided.

Channel vector

Enter a vector of numbers to specify the output channels. For example, to use the first and third digital output channels, enter

```
[1 3]
```

The channel numbers can occur in arbitrary order. Number the channels beginning with 1 even if this board manufacturer numbers them beginning with 0. The maximum allowable channel number is 16, except for the PD2-AO and PDXI-AO series. For those boards, the maximum channel number is 8.

Reset vector

The reset vector must be the same length as the channel vector. It contains values of 0 or 1. This parameter controls the behavior at model termination. A value of 1 causes the corresponding channel to be reset to the value specified in the initial value vector. A value of 0 causes the channel to remain at the last value attained while the model was running.

Initial value vector

The initial value vector must be the same length as the channel vector. It contains the initial values (0 or 1) for the output channels. The channels are set to these values between the time the model is downloaded and the time it is started.

Sample time

Enter the base sample time or a multiple of the base sample time (- 1 means sample time is inherited).

PCI slot (-1:autosearch)

If only one board of this type is in the target computer, enter - 1 to locate the board.

If two or more boards of this type are in the target computer, enter the bus number and the PCI slot number of the board associated with this driver block. Use the format [**BusNumber,SlotNumber**].

To determine the bus number and the PCI slot number, type:

```
tg = slrt;  
getPCIInfo(tg, 'installed')
```

More About

- “Specifying UEI Boards” on page 53-3

External Websites

- www.ueidaq.com

UEI PDXI-MFS 12-Bit Series

Support for the UEI PDXI-MFS 12-Bit Series I/O boards

Board Series

UEI PDXI-MFS 12-Bit Series

General Description

The PDXI-MFS 12-bit series contains I/O boards with 4 or 8 single analog input (A/D) channels (12-bit). The boards also have 2 analog output (D/A) channels (12-bit), 16 digital input, and 16 digital output lines. The Simulink Real-Time software does not support the counter/timers on these boards.

The Simulink Real-Time block library supports this series of boards with these driver blocks:

- UEI PDXI-MFS 12-Bit Series Analog Input (A/D)
- UEI PDXI-MFS 12-Bit Series Frame Analog Input
- UEI PDXI-MFS 12-Bit Series Analog Output (D/A)
- UEI PDXI-MFS 12-Bit Series Digital Input
- UEI PDXI-MFS 12-Bit Series Digital Output

Board Characteristics

Board type	PDXI-MFS-4-1M/12 PDXI-MFS-4-1M/12DG PDXI-MFS-8-1M/12 PDXI-MFS-8-1M/12DG
Manufacturer	United Electronic Industries (UEI)
Bus type	CompactPCI, PXI
Access method	Memory mapped

Multiple block instance support	No
Multiple board support	Yes

More About

- “Specifying UEI Boards” on page 53-3

External Websites

- www.ueidaq.com

UEI PDXI-MFS 12-Bit Series Analog Input (A/D)

PDXI-MFS 12-Bit Series Analog Input block

Library

Simulink Real-Time Library for UEI

Scaling Input to Output

I/O Module Input	Block Output Data Type	Scaling
Volts	Double	1

Block Parameters

Board type

Select the specific board type from the list provided.

Channel vector

Enter a vector of numbers to specify the input channels. For example, use the first and third analog input (A/D) channels, enter

[1 3]

The channel numbers can occur in arbitrary order. Number the channels beginning with 1 even if this board manufacturer numbers them beginning with 0. The maximum allowable channel number is 4, 8, 16, or 64 depending on the board type.

Gain vector

Enter a vector of numbers to select the gains for each of the channels. Available gains vary depending on board type. MF PGL gains may be set to 1, 10, 100, or 1000. MF PGH gains may be set to 1, 2, 4, or 8. MF DG-option gains may be set to 1, 2, 5, or 10.

Mux settling time vector (slow bit)

This vector must be the same length as the channel vector. It contains values of 0 or 1. If 1, the corresponding channel has a longer settling time. This is useful when using a high gain such as 100 or 1000.

Range

Select the voltage range from the list provided. This applies to all channels.

Input coupling mode

From the list, select one from the following list of input coupling modes:

- Single Ended
- Differential

Refer to the UEI PowerDAQ documentation for input connections.

Sample time

Enter the base sample time or a multiple of the base sample time (- 1 means sample time is inherited).

PCI slot (-1:autosearch)

If only one board of this type is in the target computer, enter - 1 to locate the board.

If two or more boards of this type are in the target computer, enter the bus number and the PCI slot number of the board associated with this driver block. Use the format [**BusNumber,SlotNumber**].

To determine the bus number and the PCI slot number, type:

```
tg = slrt;  
getPCIInfo(tg, 'installed')
```

More About

- “Specifying UEI Boards” on page 53-3

External Websites

- www.ueidaq.com

UEI PDXI-MFS 12-Bit Series Frame Analog Input

PDXI-MFS 12-Bit Series Frame Analog Input block

Library

Simulink Real-Time Library for UEI

Scaling Input to Output

I/O Module Input	Block Output Data Type	Scaling
Volts	Double	1

Block Parameters

Board type

Select the specific board type from the list provided.

Channel vector

Enter a vector of numbers that make up one scan. For example, to read the first and fifth channels, enter

```
[1 5]
```

The channel numbers can occur in arbitrary order. Number the channels beginning with 1 even if this board manufacturer numbers them beginning with 0. The maximum allowable channel number is 4, 8, 16, or 64 depending on the board type.

Gain vector

Enter a vector of numbers to specify the gains for each of the channels in the scan.

Enter a single value to replicate the gain value across the channels in the scan.

Available gains vary depending on board type. Allowable values depend on the board type.

- L (Low level) boards — Specify the gain as one of 1, 10, 100, or 1000.
- H (High level) boards — Specify the gain as one of 1, 2, 4, or 8.
- DG-option boards — Specify the gain as one of 1, 2, 5, or 10.

Mux settling time vector (slow bit)

Enter a vector that is the same length as the channel vector. Each vector element must be a 0 or 1. If you specify 1, the corresponding channel has a longer settling time. To get a more accurate reading, you might want to specify a 1 for channels that have higher gains, such as 100 or 1000. Refer to the UEI PowerDAQ documentation for further information on the longer settling time. This time depends on the board type.

Caution With frame based acquisition, the additional time resulting from setting the **Mux settling time vector (slow bit)** might cause an acquisition overrun that the Simulink Real-Time software does not detect. For example, on a PD2-MF-xx-333/16H board, each acquisition takes 3 microseconds if the slow bit is 0. If the slow bit is 1, that same acquisition takes more than 10 microseconds. With the Simulink Real-Time software, the scan is performed at the maximum rate for a given board. This means that the slow acquisition takes a multiple of 3 microsecond ticks. For a PD2-MF-xx-333/16H board, this becomes 12 microseconds.

For example, assume that N scans of the channel vector compose a frame of data. Assume also that you have a PD2-MF-xx-333/16H board with a **Channel vector** value of [1 2 3 4] and a **Mux settling time vector (slow bit)** value of [0 1 0 1]. For the PD2-MF-xx-333/16H board, two of the acquisition delays are 3 microseconds, and two are 12 microseconds. With a **Frame time** value of 0.001 second, if N is greater than 38, the data will not be acceptable. If you set the slow bits to 0, N can have a value of up to 83. The software detects the limit at $N = 83$, but is not aware of the extra board dependent delay.

Range

From the list, select one of the following voltage ranges. The value you select applies to all channels.

- +-10 Volts
- +-5 Volts
- 0-10 Volts
- 0-5 Volts

Input coupling mode

From the list, select one from the following list of input coupling modes:

- Single Ended
- Differential

Refer to the UEI PowerDAQ documentation for input connections.

Frame size

Enter the number of samples per channel to return as a frame of data. Due to physical constraints in the I/O module, the total number of samples in a frame of data cannot exceed 512. The relationship between the number of samples, frame size, and number of channels is

$$\text{total number of samples} = \text{FrameSize} \times \text{nChannels}$$

For example, if you specify two channels, the frame size must be less than or equal to 256.

Output format

From the list, select either **Frame** or **Vector**.

- **Frame** — Select **Frame** if you expect the output signal from this block to be the input signal for a block that requires a frame. For example, a Signal Processing block.
- **Vector** — Select **Vector** if you expect the output signal from this block to be the input signal for a Simulink Real-Time scope or some other block that requires vector input.

Scan clock source

Select **Internal** or **External** to identify the clock source for the frame scans.

Scan time

Enter the time (in seconds) between scans as the interval.

Frame time

Enter the interval (in seconds) during which the board will interrupt. The driver block evenly spaces the scans in the frame across the **Frame time** interval. If the **Frame time** interval is too short, you will receive a buffer overrun error at run time. For optimal results, experimentally increase the **Frame time** value and reiterate the process. Rebuild the model when you change this value.

The **Frame size**, **Scan time**, and **Frame time** parameters are not independent, but are related by

$$\text{Frametime} = \text{Framesize} \times \text{Scantime}.$$

After you specify two of the parameters, specify - 1 for the third parameter and the equation determines the third parameter.

Note: Because the Simulink Real-Time software uses this value to set parameters on the board, you cannot change the **Frame time** value at the MATLAB prompt.

Block is in an ISR

Select this check box if the block is in an interrupt service routine (ISR). Selecting this check box forces the block sample time to -1 , which enables the block to work in the ISR. If this check box is not selected, the block sample time is equal to the value of **Frame time**.

Slave board

If you have multiple boards configured in a master/slave combination, select this box for the slave boards only. Leave the box unchecked for the master board. (Note that a single board configuration is considered a master board.)

Note: In the model, set the priority of slave blocks higher than master blocks. Right-click the slave or master block and select **Properties**. In the dialog, enter a value in the **Priority** property. For example, if you have multiple slave blocks, you can enter values of 2 for the slave blocks and 3 for the master block, where a lower number indicates a higher priority.

Acquisition frequency

Enter the rate at which the high speed conversion clock runs. This is the clock used to acquire each scan in a frame. For example, with a PD2-MF-xx-333/16H board, the maximum clock is 333 kHz. At that rate, the second channel in a scan will be acquired 3 microseconds after the first one in every scan of the frame.

Specify - 1 to select the maximum rate available for the specified board.

DMA burst size

From the list, select either 32, 16, or 8. The DMA engine transfers data in packets of the burst size or less. Between each burst, a new bus arbitration cycle must complete. Better performance is achieved with higher **DMA burst size** values, with 32 being

highest. However, in some architectures and with some PCI bus adaptors, a **DMA burst size** of 32 might cause problems. For example, it might lock up the target computer when DMA is attempted. In these cases, reduce the **DMA burst size** value to 8, rebuild and rerun the real-time application. If the DMA works at 8, select 16 and try again.

PCI slot (-1:autosearch)

If only one board of this type is in the target computer, enter - 1 to locate the board.

If two or more boards of this type are in the target computer, enter the bus number and the PCI slot number of the board associated with this driver block. Use the format **[BusNumber,SlotNumber]**.

To determine the bus number and the PCI slot number, type:

```
tg = slrt;  
getPCIInfo(tg, 'installed')
```

More About

- “Specifying UEI Boards” on page 53-3

External Websites

- www.ueidaq.com

UEI PDXI-MFS 12-Bit Series Analog Output (D/A)

PDXI-MFS 12-Bit Series Analog Output block

Library

Simulink Real-Time Library for UEI

Scaling Input to Output

I/O Module Output	Block Input Data Type	Scaling
Volts	Double	1

Block Parameters

Board type

Select the specific board type from the list provided.

Channel vector

Enter a vector of numbers to specify the output channels 1 or 2. For example, to use the first and second analog output (D/A) channels, enter

```
[1 2]
```

The channel numbers can occur in arbitrary order. Number the channels beginning with 1 even if this board manufacturer numbers them beginning with 0.

Reset vector

The reset vector must be the same length as the channel vector. It contains values of 0 or 1. This parameter controls the behavior at model termination. A value of 1 causes the corresponding channel to be reset to the value specified in the initial value vector. A value of 0 causes the channel to remain at the last value attained while the model was running.

Initial value vector

The initial value vector must be the same length as the channel vector and should contain the initial voltage values for the output channels. The channels are set to these values between the time the model is downloaded and the time it is started.

Sample time

Enter the base sample time or a multiple of the base sample time (- 1 means sample time is inherited).

PCI slot (-1:autosearch)

If only one board of this type is in the target computer, enter - 1 to locate the board.

If two or more boards of this type are in the target computer, enter the bus number and the PCI slot number of the board associated with this driver block. Use the format **[BusNumber,SlotNumber]**.

To determine the bus number and the PCI slot number, type:

```
tg = slrt;  
getPCIInfo(tg, 'installed')
```

More About

- “Specifying UEI Boards” on page 53-3

External Websites

- www.ueidaq.com

UEI PDXI-MFS 12-Bit Series Digital Input

PDXI-MFS 12-Bit Series Digital Input block

Library

Simulink Real-Time Library for UEI

Scaling Input to Output

I/O Module Input	Block Output Data Type	Scaling
TTL	Double	TTL low = 0.0 TTL high = 1.0

Block Parameters

Board type

Select the specific board type from the list provided.

Channel vector

Enter a vector of numbers to specify the input channels. For example, to use the first and third digital input channels, enter

```
[1 3]
```

The channel numbers can occur in arbitrary order. Number the channels beginning with 1 even if this board manufacturer numbers them beginning with 0. The maximum allowable channel number is 16 except for the PD2-AO and PDXI-AO series. For those boards, the maximum channel number is 8.

Sample time

Enter the base sample time or a multiple of the base sample time (-1 means sample time is inherited).

PCI slot (-1:autosearch)

If only one board of this type is in the target computer, enter -1 to locate the board.

If two or more boards of this type are in the target computer, enter the bus number and the PCI slot number of the board associated with this driver block. Use the format **[BusNumber,SlotNumber]**.

To determine the bus number and the PCI slot number, type:

```
tg = slrt;  
getPCIInfo(tg, 'installed')
```

More About

- “Specifying UEI Boards” on page 53-3

External Websites

- www.ueidaq.com

UEI PDXI-MFS 12-Bit Series Digital Output

PDXI-MFS 12-Bit Series Digital Output block

Library

Simulink Real-Time Library for UEI

Scaling Input to Output

I/O Module Output	Block Input Data Type	Scaling
TTL	Double	< 0.5 = TTL low > 0.5 = TTL high

Block Parameters

Board type

Select the specific board type from the list provided.

Channel vector

Enter a vector of numbers to specify the output channels. For example, to use the first and third digital output channels, enter

```
[1 3]
```

The channel numbers can occur in arbitrary order. Number the channels beginning with 1 even if this board manufacturer numbers them beginning with 0. The maximum allowable channel number is 16, except for the PD2-AO and PDXI-AO series. For those boards, the maximum channel number is 8.

Reset vector

The reset vector must be the same length as the channel vector. It contains values of 0 or 1. This parameter controls the behavior at model termination. A value of 1 causes the corresponding channel to be reset to the value specified in the initial value vector. A value of 0 causes the channel to remain at the last value attained while the model was running.

Initial value vector

The initial value vector must be the same length as the channel vector. It contains the initial values (0 or 1) for the output channels. The channels are set to these values between the time the model is downloaded and the time it is started.

Sample time

Enter the base sample time or a multiple of the base sample time (- 1 means sample time is inherited).

PCI slot (-1:autosearch)

If only one board of this type is in the target computer, enter - 1 to locate the board.

If two or more boards of this type are in the target computer, enter the bus number and the PCI slot number of the board associated with this driver block. Use the format [**BusNumber,SlotNumber**].

To determine the bus number and the PCI slot number, type:

```
tg = slrt;  
getPCIInfo(tg, 'installed')
```

More About

- “Specifying UEI Boards” on page 53-3

External Websites

- www.ueidaq.com

UEI PDXI-MFS 14-Bit Series

Support for the UEI PDXI-MFS 14-Bit Series I/O boards

Board Series

UEI PDXI-MFS 14-Bit Series

General Board Series Description

The PDXI-MFS 14-bit series contains I/O boards with 4 or 8 single analog input (A/D) channels (14-bit). The boards also have 2 analog output (D/A) channels (12-bit), 16 digital input, and 16 digital output lines. The Simulink Real-Time software does not support the counter/timers on these boards.

The Simulink Real-Time block library supports this series of boards with these driver blocks:

- UEI PDXI-MFS 14-Bit Series Analog Input (A/D)
- UEI PDXI-MFS 14-Bit Series Frame Analog Input
- UEI PDXI-MFS 14-Bit Series Analog Output (D/A)
- UEI PDXI-MFS 14-Bit Series Digital Input
- UEI PDXI-MFS 14-Bit Series Digital Output

Board Characteristics

Board type	PDXI-MFS-4-500/14 PDXI-MFS-4-500/14DG PDXI-MFS-8-500/14 PDXI-MFS-8-500/14DG PDXI-MFS-4-800/14 PDXI-MFS-4-800/14DG PDXI-MFS-8-800/14 PDXI-MFS-8-800/14DG PDXI-MFS-4-2M/14
------------	--

	PDXI-MFS-4-2M/14DG PDXI-MFS-4-2M/14H PDXI-MFS-8-2M/14 PDXI-MFS-8-2M/14DG
Manufacturer	United Electronic Industries (UEI)
Bus type	CompactPCI, PXI
Access method	Memory mapped
Multiple block instance support	No
Multiple board support	Yes

More About

- “Specifying UEI Boards” on page 53-3

External Websites

- www.ueidaq.com

UEI PDXI-MFS 14-Bit Series Analog Input (A/D)

PDXI-MFS 14-Bit Series Analog Input block

Library

Simulink Real-Time Library for UEI

Scaling Input to Output

I/O Module Input	Block Output Data Type	Scaling
Volts	Double	1

Block Parameters

Board type

Select the specific board type from the list provided.

Channel vector

Enter a vector of numbers to specify the input channels. For example, use the first and third analog input (A/D) channels, enter

[1 3]

The channel numbers can occur in arbitrary order. Number the channels beginning with 1 even if this board manufacturer numbers them beginning with 0. The maximum allowable channel number is 4, 8, 16, or 64 depending on the board type.

Gain vector

Enter a vector of numbers to select the gains for each of the channels. Available gains vary depending on board type. MF PGL gains may be set to 1, 10, 100, or 1000. MF PGH gains may be set to 1, 2, 4, or 8. MF DG-option gains may be set to 1, 2, 5, or 10.

Mux settling time vector (slow bit)

This vector must be the same length as the channel vector. It contains values of 0 or 1. If 1, the corresponding channel has a longer settling time. This is useful when using a high gain such as 100 or 1000.

Range

Select the voltage range from the list provided. This applies to all channels.

Input coupling mode

From the list, select one from the following list of input coupling modes:

- Single Ended
- Differential

Refer to the UEI PowerDAQ documentation for input connections.

Sample time

Enter the base sample time or a multiple of the base sample time (- 1 means sample time is inherited).

PCI slot (-1:autosearch)

If only one board of this type is in the target computer, enter - 1 to locate the board.

If two or more boards of this type are in the target computer, enter the bus number and the PCI slot number of the board associated with this driver block. Use the format [**BusNumber,SlotNumber**].

To determine the bus number and the PCI slot number, type:

```
tg = slrt;  
getPCIInfo(tg, 'installed')
```

More About

- “Specifying UEI Boards” on page 53-3

External Websites

- www.ueidaq.com

UEI PDXI-MFS 14-Bit Series Frame Analog Input

PDXI-MFS 14-Bit Series Frame Analog Input block

Library

Simulink Real-Time Library for UEI

Scaling Input to Output

I/O Module Input	Block Output Data Type	Scaling
Volts	Double	1

Block Parameters

Board type

Select the specific board type from the list provided.

Channel vector

Enter a vector of numbers that make up one scan. For example, to read the first and fifth channels, enter

```
[1 5]
```

The channel numbers can occur in arbitrary order. Number the channels beginning with 1 even if this board manufacturer numbers them beginning with 0. The maximum allowable channel number is 4, 8, 16, or 64 depending on the board type.

Gain vector

Enter a vector of numbers to specify the gains for each of the channels in the scan.

Enter a single value to replicate the gain value across the channels in the scan.

Available gains vary depending on board type. Allowable values depend on the board type.

- L (Low level) boards — Specify the gain as one of 1, 10, 100, or 1000.
- H (High level) boards — Specify the gain as one of 1, 2, 4, or 8.
- DG-option boards — Specify the gain as one of 1, 2, 5, or 10.

Mux settling time vector (slow bit)

Enter a vector that is the same length as the channel vector. Each vector element must be a 0 or 1. If you specify 1, the corresponding channel has a longer settling time. To get a more accurate reading, you might want to specify a 1 for channels that have higher gains, such as 100 or 1000. Refer to the UEI PowerDAQ documentation for further information on the longer settling time. This time depends on the board type.

Caution With frame based acquisition, the additional time resulting from setting the **Mux settling time vector (slow bit)** might cause an acquisition overrun that the Simulink Real-Time software does not detect. For example, on a PD2-MF-xx-333/16H board, each acquisition takes 3 microseconds if the slow bit is 0. If the slow bit is 1, that same acquisition takes more than 10 microseconds. With the Simulink Real-Time software, the scan is performed at the maximum rate for a given board. This means that the slow acquisition takes a multiple of 3 microsecond ticks. For a PD2-MF-xx-333/16H board, this becomes 12 microseconds.

For example, assume that N scans of the channel vector compose a frame of data. Assume also that you have a PD2-MF-xx-333/16H board with a **Channel vector** value of [1 2 3 4] and a **Mux settling time vector (slow bit)** value of [0 1 0 1]. For the PD2-MF-xx-333/16H board, two of the acquisition delays are 3 microseconds, and two are 12 microseconds. With a **Frame time** value of 0.001 second, if N is greater than 38, the data will not be acceptable. If you set the slow bits to 0, N can have a value of up to 83. The software detects the limit at $N = 83$, but is not aware of the extra board dependent delay.

Range

From the list, select one of the following voltage ranges. The value you select applies to all channels.

- +-10 Volts
- +-5 Volts
- 0-10 Volts
- 0-5 Volts

Input coupling mode

From the list, select one from the following list of input coupling modes:

- Single Ended
- Differential

Refer to the UEI PowerDAQ documentation for input connections.

Frame size

Enter the number of samples per channel to return as a frame of data. Due to physical constraints in the I/O module, the total number of samples in a frame of data cannot exceed 512. The relationship between the number of samples, frame size, and number of channels is

total number of samples = FrameSize x nChannels

For example, if you specify two channels, the frame size must be less than or equal to 256.

Output format

From the list, select either **Frame** or **Vector**.

- **Frame** — Select **Frame** if you expect the output signal from this block to be the input signal for a block that requires a frame. For example, a **Signal Processing** block.
- **Vector** — Select **Vector** if you expect the output signal from this block to be the input signal for a **Simulink Real-Time** scope or some other block that requires vector input.

Scan clock source

Select **Internal** or **External** to identify the clock source for the frame scans.

Scan time

Enter the time (in seconds) between scans as the interval.

Frame time

Enter the interval (in seconds) during which the board will interrupt. The driver block evenly spaces the scans in the frame across the **Frame time** interval. If the **Frame time** interval is too short, you will receive a buffer overrun error at run time. For optimal results, experimentally increase the **Frame time** value and reiterate the process. Rebuild the model when you change this value.

The **Frame size**, **Scan time**, and **Frame time** parameters are not independent, but are related by

$$\text{Frametime} = \text{Framesize} \times \text{Scantime}.$$

After you specify two of the parameters, specify -1 for the third parameter and the equation determines the third parameter.

Note: Because the Simulink Real-Time software uses this value to set parameters on the board, you cannot change the **Frame time** value at the MATLAB prompt.

Block is in an ISR

Select this check box if the block is in an interrupt service routine (ISR). Selecting this check box forces the block sample time to -1 , which enables the block to work in the ISR. If this check box is not selected, the block sample time is equal to the value of **Frame time**.

Slave board

If you have multiple boards configured in a master/slave combination, select this box for the slave boards only. Leave the box unchecked for the master board. (Note that a single board configuration is considered a master board.)

Note: In the model, set the priority of slave blocks higher than master blocks. Right-click the slave or master block and select **Properties**. In the dialog, enter a value in the **Priority** property. For example, if you have multiple slave blocks, you can enter values of 2 for the slave blocks and 3 for the master block, where a lower number indicates a higher priority.

Acquisition frequency

Enter the rate at which the high speed conversion clock runs. This is the clock used to acquire each scan in a frame. For example, with a PD2-MF-xx-333/16H board, the maximum clock is 333 kHz. At that rate, the second channel in a scan will be acquired 3 microseconds after the first one in every scan of the frame.

Specify -1 to select the maximum rate available for the specified board.

DMA burst size

From the list, select either 32, 16, or 8. The DMA engine transfers data in packets of the burst size or less. Between each burst, a new bus arbitration cycle must complete. Better performance is achieved with higher **DMA burst size** values, with 32 being

highest. However, in some architectures and with some PCI bus adaptors, a **DMA burst size** of 32 might cause problems. For example, it might lock up the target computer when DMA is attempted. In these cases, reduce the **DMA burst size** value to 8, rebuild and rerun the real-time application. If the DMA works at 8, select 16 and try again.

PCI slot (-1:autosearch)

If only one board of this type is in the target computer, enter - 1 to locate the board.

If two or more boards of this type are in the target computer, enter the bus number and the PCI slot number of the board associated with this driver block. Use the format **[BusNumber,SlotNumber]**.

To determine the bus number and the PCI slot number, type:

```
tg = slrt;  
getPCIInfo(tg, 'installed')
```

More About

- “Specifying UEI Boards” on page 53-3

External Websites

- www.ueidaq.com

UEI PDXI-MFS 14-Bit Series Analog Output (D/A)

PDXI-MFS 14-Bit Series Analog Output block

Library

Simulink Real-Time Library for UEI

Scaling Input to Output

I/O Module Output	Block Input Data Type	Scaling
Volts	Double	1

Block Parameters

Board type

Select the specific board type from the list provided.

Channel vector

Enter a vector of numbers to specify the output channels 1 or 2. For example, to use the first and second analog output (D/A) channels, enter

```
[1 2]
```

The channel numbers can occur in arbitrary order. Number the channels beginning with 1 even if this board manufacturer numbers them beginning with 0.

Reset vector

The reset vector must be the same length as the channel vector. It contains values of 0 or 1. This parameter controls the behavior at model termination. A value of 1 causes the corresponding channel to be reset to the value specified in the initial value vector. A value of 0 causes the channel to remain at the last value attained while the model was running.

Initial value vector

The initial value vector must be the same length as the channel vector and should contain the initial voltage values for the output channels. The channels are set to these values between the time the model is downloaded and the time it is started.

Sample time

Enter the base sample time or a multiple of the base sample time (- 1 means sample time is inherited).

PCI slot (-1:autosearch)

If only one board of this type is in the target computer, enter - 1 to locate the board.

If two or more boards of this type are in the target computer, enter the bus number and the PCI slot number of the board associated with this driver block. Use the format **[BusNumber,SlotNumber]**.

To determine the bus number and the PCI slot number, type:

```
tg = slrt;  
getPCIInfo(tg, 'installed')
```

More About

- “Specifying UEI Boards” on page 53-3

External Websites

- www.ueidaq.com

UEI PDXI-MFS 14-Bit Series Digital Input

PDXI-MFS 14-Bit Series Digital Input block

Library

Simulink Real-Time Library for UEI

Scaling Input to Output

I/O Module Input	Block Output Data Type	Scaling
TTL	Double	TTL low = 0.0 TTL high = 1.0

Block Parameters

Board type

Select the specific board type from the list provided.

Channel vector

Enter a vector of numbers to specify the input channels. For example, to use the first and third digital input channels, enter

```
[1 3]
```

The channel numbers can occur in arbitrary order. Number the channels beginning with 1 even if this board manufacturer numbers them beginning with 0. The maximum allowable channel number is 16 except for the PD2-AO and PDXI-AO series. For those boards, the maximum channel number is 8.

Sample time

Enter the base sample time or a multiple of the base sample time (-1 means sample time is inherited).

PCI slot (-1:autosearch)

If only one board of this type is in the target computer, enter -1 to locate the board.

If two or more boards of this type are in the target computer, enter the bus number and the PCI slot number of the board associated with this driver block. Use the format **[BusNumber,SlotNumber]**.

To determine the bus number and the PCI slot number, type:

```
tg = slrt;  
getPCIInfo(tg, 'installed')
```

More About

- “Specifying UEI Boards” on page 53-3

External Websites

- www.ueidaq.com

UEI PDXI-MFS 14-Bit Series Digital Output

PDXI-MFS 14-Bit Series Digital Output block

Library

Simulink Real-Time Library for UEI

Scaling Input to Output

I/O Module Output	Block Input Data Type	Scaling
TTL	Double	< 0.5 = TTL low > 0.5 = TTL high

Block Parameters

Board type

Select the specific board type from the list provided.

Channel vector

Enter a vector of numbers to specify the output channels. For example, to use the first and third digital output channels, enter

```
[1 3]
```

The channel numbers can occur in arbitrary order. Number the channels beginning with 1 even if this board manufacturer numbers them beginning with 0. The maximum allowable channel number is 16, except for the PD2-AO and PDXI-AO series. For those boards, the maximum channel number is 8.

Reset vector

The reset vector must be the same length as the channel vector. It contains values of 0 or 1. This parameter controls the behavior at model termination. A value of 1 causes the corresponding channel to be reset to the value specified in the initial value vector. A value of 0 causes the channel to remain at the last value attained while the model was running.

Initial value vector

The initial value vector must be the same length as the channel vector. It contains the initial values (0 or 1) for the output channels. The channels are set to these values between the time the model is downloaded and the time it is started.

Sample time

Enter the base sample time or a multiple of the base sample time (- 1 means sample time is inherited).

PCI slot (-1:autosearch)

If only one board of this type is in the target computer, enter - 1 to locate the board.

If two or more boards of this type are in the target computer, enter the bus number and the PCI slot number of the board associated with this driver block. Use the format [**BusNumber,SlotNumber**].

To determine the bus number and the PCI slot number, type:

```
tg = slrt;  
getPCIInfo(tg, 'installed')
```

More About

- “Specifying UEI Boards” on page 53-3

External Websites

- www.ueidaq.com

UEI PDXI-MFS 16-Bit Series

Support for the UEI PDXI-MFS 16-Bit Series I/O boards

Board Series

UEI PDXI-MFS 16-Bit Series

General Board Series Description

The PDXI-MFS 16-bit series contains I/O boards with 4 or 8 single analog input (A/D) channels (16-bit). The boards also have 2 analog output (D/A) channels (12-bit), 16 digital input, and 16 digital output lines. The Simulink Real-Time software does not support the counter/timers on these boards.

The Simulink Real-Time block library supports this series of boards with these driver blocks:

- UEI PDXI-MFS 16-Bit Series Analog Input (A/D)
- UEI PDXI-MFS 16-Bit Series Frame Analog Input
- UEI PDXI-MFS 16-Bit Series Analog Output (D/A)
- UEI PDXI-MFS 16-Bit Series Digital Input
- UEI PDXI-MFS 16-Bit Series Digital Output

Board Characteristics

Board type	PDXI-MFS-4-300/16 PDXI-MFS-4-300/16DG PDXI-MFS-8-300/16 PDXI-MFS-8-300/16DG PDXI-MFS-4-500/16 PDXI-MFS-4-500/16DG PDXI-MFS-8-500/16 PDXI-MFS-8-500/16DG
------------	--

Manufacturer	United Electronic Industries (UEI)
Bus type	CompactPCI, PXI
Access method	Memory mapped
Multiple block instance support	No
Multiple board support	Yes

More About

- “Specifying UEI Boards” on page 53-3

External Websites

- www.ueidaq.com

UEI PDXI-MFS 16-Bit Series Analog Input (A/D)

PDXI-MFS 16-Bit Series Analog Input block

Library

Simulink Real-Time Library for UEI

Scaling Input to Output

I/O Module Input	Block Output Data Type	Scaling
Volts	Double	1

Block Parameters

Board type

Select the specific board type from the list provided.

Channel vector

Enter a vector of numbers to specify the input channels. For example, use the first and third analog input (A/D) channels, enter

[1 3]

The channel numbers can occur in arbitrary order. Number the channels beginning with 1 even if this board manufacturer numbers them beginning with 0. The maximum allowable channel number is 4, 8, 16, or 64 depending on the board type.

Gain vector

Enter a vector of numbers to select the gains for each of the channels. Available gains vary depending on board type. MF PGL gains may be set to 1, 10, 100, or 1000. MF PGH gains may be set to 1, 2, 4, or 8. MF DG-option gains may be set to 1, 2, 5, or 10.

Mux settling time vector (slow bit)

This vector must be the same length as the channel vector. It contains values of 0 or 1. If 1, the corresponding channel has a longer settling time. This is useful when using a high gain such as 100 or 1000.

Range

Select the voltage range from the list provided. This applies to all channels.

Input coupling mode

From the list, select one from the following list of input coupling modes:

- Single Ended
- Differential

Refer to the UEI PowerDAQ documentation for input connections.

Sample time

Enter the base sample time or a multiple of the base sample time (- 1 means sample time is inherited).

PCI slot (-1:autosearch)

If only one board of this type is in the target computer, enter - 1 to locate the board.

If two or more boards of this type are in the target computer, enter the bus number and the PCI slot number of the board associated with this driver block. Use the format [**BusNumber,SlotNumber**].

To determine the bus number and the PCI slot number, type:

```
tg = slrt;  
getPCIInfo(tg, 'installed')
```

More About

- “Specifying UEI Boards” on page 53-3

External Websites

- www.ueidaq.com

UEI PDXI-MFS 16-Bit Series Frame Analog Input

PDXI-MFS 16-Bit Series Frame Analog Input block

Library

Simulink Real-Time Library for UEI

Scaling Input to Output

I/O Module Input	Block Output Data Type	Scaling
Volts	Double	1

Block Parameters

Board type

Select the specific board type from the list provided.

Channel vector

Enter a vector of numbers that make up one scan. For example, to read the first and fifth channels, enter

```
[1 5]
```

The channel numbers can occur in arbitrary order. Number the channels beginning with 1 even if this board manufacturer numbers them beginning with 0. The maximum allowable channel number is 4, 8, 16, or 64 depending on the board type.

Gain vector

Enter a vector of numbers to specify the gains for each of the channels in the scan.

Enter a single value to replicate the gain value across the channels in the scan.

Available gains vary depending on board type. Allowable values depend on the board type.

- L (Low level) boards — Specify the gain as one of 1, 10, 100, or 1000.
- H (High level) boards — Specify the gain as one of 1, 2, 4, or 8.
- DG-option boards — Specify the gain as one of 1, 2, 5, or 10.

Mux settling time vector (slow bit)

Enter a vector that is the same length as the channel vector. Each vector element must be a 0 or 1. If you specify 1, the corresponding channel has a longer settling time. To get a more accurate reading, you might want to specify a 1 for channels that have higher gains, such as 100 or 1000. Refer to the UEI PowerDAQ documentation for further information on the longer settling time. This time depends on the board type.

Caution With frame based acquisition, the additional time resulting from setting the **Mux settling time vector (slow bit)** might cause an acquisition overrun that the Simulink Real-Time software does not detect. For example, on a PD2-MF-xx-333/16H board, each acquisition takes 3 microseconds if the slow bit is 0. If the slow bit is 1, that same acquisition takes more than 10 microseconds. With the Simulink Real-Time software, the scan is performed at the maximum rate for a given board. This means that the slow acquisition takes a multiple of 3 microsecond ticks. For a PD2-MF-xx-333/16H board, this becomes 12 microseconds.

For example, assume that N scans of the channel vector compose a frame of data. Assume also that you have a PD2-MF-xx-333/16H board with a **Channel vector** value of [1 2 3 4] and a **Mux settling time vector (slow bit)** value of [0 1 0 1]. For the PD2-MF-xx-333/16H board, two of the acquisition delays are 3 microseconds, and two are 12 microseconds. With a **Frame time** value of 0.001 second, if N is greater than 38, the data will not be acceptable. If you set the slow bits to 0, N can have a value of up to 83. The software detects the limit at $N = 83$, but is not aware of the extra board dependent delay.

Range

From the list, select one of the following voltage ranges. The value you select applies to all channels.

- +-10 Volts
- +-5 Volts
- 0-10 Volts
- 0-5 Volts

Input coupling mode

From the list, select one from the following list of input coupling modes:

- Single Ended
- Differential

Refer to the UEI PowerDAQ documentation for input connections.

Frame size

Enter the number of samples per channel to return as a frame of data. Due to physical constraints in the I/O module, the total number of samples in a frame of data cannot exceed 512. The relationship between the number of samples, frame size, and number of channels is

$$\text{total number of samples} = \text{FrameSize} \times \text{nChannels}$$

For example, if you specify two channels, the frame size must be less than or equal to 256.

Output format

From the list, select either **Frame** or **Vector**.

- **Frame** — Select **Frame** if you expect the output signal from this block to be the input signal for a block that requires a frame. For example, a Signal Processing block.
- **Vector** — Select **Vector** if you expect the output signal from this block to be the input signal for a Simulink Real-Time scope or some other block that requires vector input.

Scan clock source

Select **Internal** or **External** to identify the clock source for the frame scans.

Scan time

Enter the time (in seconds) between scans as the interval.

Frame time

Enter the interval (in seconds) during which the board will interrupt. The driver block evenly spaces the scans in the frame across the **Frame time** interval. If the **Frame time** interval is too short, you will receive a buffer overrun error at run time. For optimal results, experimentally increase the **Frame time** value and reiterate the process. Rebuild the model when you change this value.

The **Frame size**, **Scan time**, and **Frame time** parameters are not independent, but are related by

$$\text{Frametime} = \text{Framesize} \times \text{Scantime}.$$

After you specify two of the parameters, specify - 1 for the third parameter and the equation determines the third parameter.

Note: Because the Simulink Real-Time software uses this value to set parameters on the board, you cannot change the **Frame time** value at the MATLAB prompt.

Block is in an ISR

Select this check box if the block is in an interrupt service routine (ISR). Selecting this check box forces the block sample time to -1 , which enables the block to work in the ISR. If this check box is not selected, the block sample time is equal to the value of **Frame time**.

Slave board

If you have multiple boards configured in a master/slave combination, select this box for the slave boards only. Leave the box unchecked for the master board. (Note that a single board configuration is considered a master board.)

Note: In the model, set the priority of slave blocks higher than master blocks. Right-click the slave or master block and select **Properties**. In the dialog, enter a value in the **Priority** property. For example, if you have multiple slave blocks, you can enter values of 2 for the slave blocks and 3 for the master block, where a lower number indicates a higher priority.

Acquisition frequency

Enter the rate at which the high speed conversion clock runs. This is the clock used to acquire each scan in a frame. For example, with a PD2-MF-xx-333/16H board, the maximum clock is 333 kHz. At that rate, the second channel in a scan will be acquired 3 microseconds after the first one in every scan of the frame.

Specify - 1 to select the maximum rate available for the specified board.

DMA burst size

From the list, select either 32, 16, or 8. The DMA engine transfers data in packets of the burst size or less. Between each burst, a new bus arbitration cycle must complete. Better performance is achieved with higher **DMA burst size** values, with 32 being

highest. However, in some architectures and with some PCI bus adaptors, a **DMA burst size** of 32 might cause problems. For example, it might lock up the target computer when DMA is attempted. In these cases, reduce the **DMA burst size** value to 8, rebuild and rerun the real-time application. If the DMA works at 8, select 16 and try again.

PCI slot (-1:autosearch)

If only one board of this type is in the target computer, enter - 1 to locate the board.

If two or more boards of this type are in the target computer, enter the bus number and the PCI slot number of the board associated with this driver block. Use the format **[BusNumber,SlotNumber]**.

To determine the bus number and the PCI slot number, type:

```
tg = slrt;  
getPCIInfo(tg, 'installed')
```

More About

- “Specifying UEI Boards” on page 53-3

External Websites

- www.ueidaq.com

UEI PDXI-MFS 16-Bit Series Analog Output (D/A)

PDXI-MFS 16-Bit Series Analog Output block

Library

Simulink Real-Time Library for UEI

Scaling Input to Output

I/O Module Output	Block Input Data Type	Scaling
Volts	Double	1

Block Parameters

Board type

Select the specific board type from the list provided.

Channel vector

Enter a vector of numbers to specify the output channels 1 or 2. For example, to use the first and second analog output (D/A) channels, enter

```
[1 2]
```

The channel numbers can occur in arbitrary order. Number the channels beginning with 1 even if this board manufacturer numbers them beginning with 0.

Reset vector

The reset vector must be the same length as the channel vector. It contains values of 0 or 1. This parameter controls the behavior at model termination. A value of 1 causes the corresponding channel to be reset to the value specified in the initial value vector. A value of 0 causes the channel to remain at the last value attained while the model was running.

Initial value vector

The initial value vector must be the same length as the channel vector and should contain the initial voltage values for the output channels. The channels are set to these values between the time the model is downloaded and the time it is started.

Sample time

Enter the base sample time or a multiple of the base sample time (- 1 means sample time is inherited).

PCI slot (-1:autosearch)

If only one board of this type is in the target computer, enter - 1 to locate the board.

If two or more boards of this type are in the target computer, enter the bus number and the PCI slot number of the board associated with this driver block. Use the format **[BusNumber,SlotNumber]**.

To determine the bus number and the PCI slot number, type:

```
tg = slrt;  
getPCIInfo(tg, 'installed')
```

More About

- “Specifying UEI Boards” on page 53-3

External Websites

- www.ueidaq.com

UEI PDXI-MFS 16-Bit Series Digital Input

PDXI-MFS 16-Bit Series Digital Input block

Library

Simulink Real-Time Library for UEI

Scaling Input to Output

I/O Module Input	Block Output Data Type	Scaling
TTL	Double	TTL low = 0.0 TTL high = 1.0

Block Parameters

Board type

Select the specific board type from the list provided.

Channel vector

Enter a vector of numbers to specify the input channels. For example, to use the first and third digital input channels, enter

```
[1 3]
```

The channel numbers can occur in arbitrary order. Number the channels beginning with 1 even if this board manufacturer numbers them beginning with 0. The maximum allowable channel number is 16 except for the PD2-AO and PDXI-AO series. For those boards, the maximum channel number is 8.

Sample time

Enter the base sample time or a multiple of the base sample time (-1 means sample time is inherited).

PCI slot (-1:autosearch)

If only one board of this type is in the target computer, enter -1 to locate the board.

If two or more boards of this type are in the target computer, enter the bus number and the PCI slot number of the board associated with this driver block. Use the format **[BusNumber,SlotNumber]**.

To determine the bus number and the PCI slot number, type:

```
tg = slrt;  
getPCIInfo(tg, 'installed')
```

More About

- “Specifying UEI Boards” on page 53-3

External Websites

- www.ueidaq.com

UEI PDXI-MFS 16-Bit Series Digital Output

PDXI-MFS 16-Bit Series Digital Output block

Library

Simulink Real-Time Library for UEI

Scaling Input to Output

I/O Module Output	Block Input Data Type	Scaling
TTL	Double	< 0.5 = TTL low > 0.5 = TTL high

Block Parameters

Board type

Select the specific board type from the list provided.

Channel vector

Enter a vector of numbers to specify the output channels. For example, to use the first and third digital output channels, enter

```
[1 3]
```

The channel numbers can occur in arbitrary order. Number the channels beginning with 1 even if this board manufacturer numbers them beginning with 0. The maximum allowable channel number is 16, except for the PD2-AO and PDXI-AO series. For those boards, the maximum channel number is 8.

Reset vector

The reset vector must be the same length as the channel vector. It contains values of 0 or 1. This parameter controls the behavior at model termination. A value of 1 causes the corresponding channel to be reset to the value specified in the initial value vector. A value of 0 causes the channel to remain at the last value attained while the model was running.

Initial value vector

The initial value vector must be the same length as the channel vector. It contains the initial values (0 or 1) for the output channels. The channels are set to these values between the time the model is downloaded and the time it is started.

Sample time

Enter the base sample time or a multiple of the base sample time (- 1 means sample time is inherited).

PCI slot (-1:autosearch)

If only one board of this type is in the target computer, enter - 1 to locate the board.

If two or more boards of this type are in the target computer, enter the bus number and the PCI slot number of the board associated with this driver block. Use the format [**BusNumber,SlotNumber**].

To determine the bus number and the PCI slot number, type:

```
tg = slrt;  
getPCIInfo(tg, 'installed')
```

More About

- “Specifying UEI Boards” on page 53-3

External Websites

- www.ueidaq.com

UEI PD2-AO Series

Support for the UEI PD2-AO Series I/O boards

Board Series

UEI PD2-AO Series

General Board Series Description

The PD2-AO series boards have 8, 16, 32, or 96 analog output (D/A) channels (16-bit) with a maximum sample rate of 100 kHz per channel. They also have 8 digital input and 8 digital output lines.

The Simulink Real-Time block library supports this series of boards with these driver blocks:

- UEI PD2-AO Analog Output (D/A)
- UEI PD2-AO Digital Input
- UEI PD2-AO Digital Output

Board Characteristics

Board type	PD2-AO-8/16 PD2-AO-16/16 PD2-AO-32/16 PD2-AO-96/16
Manufacturer	United Electronic Industries (UEI)
Bus type	PCI
Access method	Memory mapped
Multiple block instance support	No
Multiple board support	Yes

More About

- “Specifying UEI Boards” on page 53-3

External Websites

- www.ueidaq.com

UEI PD2-AO Analog Output (D/A)

PD2-AO Analog Output block

Library

Simulink Real-Time Library for UEI

Scaling Input to Output

I/O Module Output	Block Input Data Type	Scaling
Volts	Double	1

Block Parameters

Board type

Select the specific board type from the list provided.

Channel vector

Enter a vector of numbers to specify the output channels between 1 and 8, 1 and 16, 1 and 32, or 1 and 96. For example, to use the first and second analog output (D/A) channels, enter

```
[1 2]
```

The channel numbers can occur in arbitrary order. Number the channels beginning with 1 even if this board manufacturer numbers them beginning with 0. The maximum allowable channel number for PD2-AO series boards is 8, 16, 32, or 96 depending on the specific board type.

Note, the UEI PD2-AO 96 channel board only works if you specify a contiguous group of channels. These channels also must be listed in order. If you enter a non-contiguous channel list in the **Channel** vector parameter, the board does not produce output.

As a workaround, enter a contiguous specification like:

[1 2 3 4 5]

to use channels 1, 3, and 5. Connect a Simulink ground to channels 2 and 4.

Reset vector

The reset vector must be the same length as the channel vector. It contains values of 0 or 1. This parameter controls the behavior at model termination. A value of 1 causes the corresponding channel to be reset to the value specified in the initial value vector. A value of 0 causes the channel to remain at the last value attained while the model was running.

If your board is the 96 channel version, the board reads only the first value in the vector and resets the channels according to that first value. For example, if the first value of the vector is 1, the board resets all 96 channels to the values specified in the **Initial value vector** parameter.

Initial value vector

The initial value vector must be the same length as the channel vector and should contain the initial voltage values for the output channels. The channels are set to these values between the time the model is downloaded and the time it is started.

Sample time

Enter the base sample time or a multiple of the base sample time (-1 means sample time is inherited).

PCI slot (-1:autosearch)

If only one board of this type is in the target computer, enter -1 to locate the board.

If two or more boards of this type are in the target computer, enter the bus number and the PCI slot number of the board associated with this driver block. Use the format **[BusNumber, SlotNumber]**.

To determine the bus number and the PCI slot number, type:

```
tg = slrt;
getPCIInfo(tg, 'installed')
```

More About

- “Specifying UEI Boards” on page 53-3

External Websites

- www.ueidaq.com

UEI PD2-AO Digital Input

PD2-AO Digital Input block

Library

Simulink Real-Time Library for UEI

Scaling Input to Output

I/O Module Input	Block Output Data Type	Scaling
TTL	Double	TTL low = 0.0 TTL high = 1.0

Block Parameters

Board type

Select the specific board type from the list provided.

Channel vector

Enter a vector of numbers to specify the input channels. For example, to use the first and third digital input channels, enter

```
[1 3]
```

The channel numbers can occur in arbitrary order. Number the channels beginning with 1 even if this board manufacturer numbers them beginning with 0. The maximum allowable channel number is 16 except for the PD2-AO and PDXI-AO series. For those boards, the maximum channel number is 8.

Sample time

Enter the base sample time or a multiple of the base sample time (-1 means sample time is inherited).

PCI slot (-1:autosearch)

If only one board of this type is in the target computer, enter -1 to locate the board.

If two or more boards of this type are in the target computer, enter the bus number and the PCI slot number of the board associated with this driver block. Use the format **[BusNumber,SlotNumber]**.

To determine the bus number and the PCI slot number, type:

```
tg = slrt;  
getPCIInfo(tg, 'installed')
```

More About

- “Specifying UEI Boards” on page 53-3

External Websites

- www.ueidaq.com

UEI PD2-AO Digital Output

PD2-AO Digital Output block

Library

Simulink Real-Time Library for UEI

Scaling Input to Output

I/O Module Output	Block Input Data Type	Scaling
TTL	Double	< 0.5 = TTL low > 0.5 = TTL high

Block Parameters

Board type

Select the specific board type from the list provided.

Channel vector

Enter a vector of numbers to specify the output channels. For example, to use the first and third digital output channels, enter

```
[1 3]
```

The channel numbers can occur in arbitrary order. Number the channels beginning with 1 even if this board manufacturer numbers them beginning with 0. The maximum allowable channel number is 16, except for the PD2-AO and PDXI-AO series. For those boards, the maximum channel number is 8.

Reset vector

The reset vector must be the same length as the channel vector. It contains values of 0 or 1. This parameter controls the behavior at model termination. A value of 1 causes the corresponding channel to be reset to the value specified in the initial value vector. A value of 0 causes the channel to remain at the last value attained while the model was running.

Initial value vector

The initial value vector must be the same length as the channel vector. It contains the initial values (0 or 1) for the output channels. The channels are set to these values between the time the model is downloaded and the time it is started.

Sample time

Enter the base sample time or a multiple of the base sample time (- 1 means sample time is inherited).

PCI slot (-1:autosearch)

If only one board of this type is in the target computer, enter - 1 to locate the board.

If two or more boards of this type are in the target computer, enter the bus number and the PCI slot number of the board associated with this driver block. Use the format [**BusNumber,SlotNumber**].

To determine the bus number and the PCI slot number, type:

```
tg = slrt;  
getPCIInfo(tg, 'installed')
```

More About

- “Specifying UEI Boards” on page 53-3

External Websites

- www.ueidaq.com

UEI PD2-DIO-64

Support for the UEI PD2-DIO-64 series I/O boards

Board Series

UEI PD2-DIO-64

General Board Series Description

The PD2-DIO-64 series PCI boards have 64 digital I/O channels in 16-bit ports, three counters/timers, two enhanced synchronous serial interface (ESSI) ports, and four high-speed (100 ns) IRQ lines.

The Simulink Real-Time block library supports this series of boards with these driver blocks:

- UEI PD2-DIO-64 Digital Input
- UEI PD2-DIO-64 Digital Output

The Simulink Real-Time software only supports the digital I/O channels for this board series. It does not support the additional functionality.

Board Characteristics

Board type	PD2-DIO-64 PD2-DIO-64ST PD2-DIO-64CT PD2-DIO-64TS
Manufacturer	United Electronic Industries (UEI)
Bus type	PCI
Access method	Memory mapped
Multiple block instance support	No
Multiple board support	Yes

More About

- “Specifying UEI Boards” on page 53-3

External Websites

- www.ueidaq.com

UEI PD2-DIO-64 Digital Input

PD2-DIO-64 Digital Input block

Library

Simulink Real-Time Library for UEI

Scaling Input to Output

I/O Module Input	Block Output Data Type	Scaling
TTL	Double	TTL low = 0.0 TTL high = 1.0

Note

Note that each block of 16 ports must be input or output.

Block Parameters

Board type

Select the specific board type from the list provided.

Port (first channel of port)

From the list, select the first channel of the port. Each port is 16 bits. This value plus the **Channel vector** value appear on the terminal block.

Channel vector

Enter a vector of numbers to specify the input channels. For example, to use the first and third digital input channels, enter

```
[1 3]
```

The channel numbers can occur in arbitrary order. Number the channels beginning with 0, which is the same as the numbering on the I/O module label.

Sample time

Enter the base sample time or a multiple of the base sample time (- 1 means sample time is inherited).

PCI slot (-1:autosearch)

If only one board of this type is in the target computer, enter - 1 to locate the board.

If two or more boards of this type are in the target computer, enter the bus number and the PCI slot number of the board associated with this driver block. Use the format **[BusNumber,SlotNumber]**.

To determine the bus number and the PCI slot number, type:

```
tg = slrt;  
getPCIInfo(tg, 'installed')
```

More About

- “Specifying UEI Boards” on page 53-3

External Websites

- www.ueidaq.com

UEI PD2-DIO-64 Digital Output

PD2-DIO-64 Digital Output block

Library

Simulink Real-Time Library for UEI

Scaling Input to Output

I/O Module Output	Block Input Data Type	Scaling
TTL	Double	< 0.5 = TTL low > 0.5 = TTL high

Block Parameters

Board type

Select the specific board type from the list provided.

Port (first channel of port)

From the list, select the first channel of the port. Each port is 16 bits. This value and the **Channel vector** value appear on the terminal block.

Channel vector

Enter a vector of numbers to specify the output channels. For example, to use the first and third digital output channels, enter

```
[1 3]
```

The channel numbers can occur in arbitrary order. Number the channels beginning with 0, which is the same as the numbering on the I/O module label.

Reset vector

The reset vector controls the behavior of the channel at model termination. Enter a scalar or a vector that is the same length as the channel vector. If you specify a scalar value, that setting is replicated over the channel vector. If you specify a value of 1,

the corresponding channel is reset to the value specified in the initial value vector. If you specify a value of 0, the channel remains at the last value attained while the model was running.

Initial value vector

The initial value vector contains the initial values (0 or 1) of the output channels. Enter a scalar or a vector that is the same length as the channel vector. If you enter a scalar, that value is replicated as the initial value over the channel vector. The channels are set to these initial values between the time the model is downloaded and the time it is started.

Sample time

Enter the base sample time or a multiple of the base sample time (- 1 means sample time is inherited).

PCI slot (-1:autosearch)

If only one board of this type is in the target computer, enter - 1 to locate the board.

If two or more boards of this type are in the target computer, enter the bus number and the PCI slot number of the board associated with this driver block. Use the format **[BusNumber, SlotNumber]**.

To determine the bus number and the PCI slot number, type:

```
tg = slrt;  
getPCIInfo(tg, 'installed')
```

More About

- “Specifying UEI Boards” on page 53-3

External Websites

- www.ueidaq.com

UEI PD2-DIO-128

Support for the UEI PD2-DIO-128 Series I/O boards

Board Series

UEI PD2-DIO-128

General Board Series

The PD2-DIO-128 series PCI boards have 128 digital I/O channels in 16-bit ports, three counters/timers, two enhanced synchronous serial interface (ESSI) ports, and four high-speed (100 ns) IRQ lines.

The Simulink Real-Time block library supports this series of boards with these driver blocks:

- UEI PD2-DIO-128 Digital Input
- UEI PD2-DIO-128 Digital Output

The Simulink Real-Time software only supports the digital I/O channels for this board series. It does not support the additional functionality.

Board Characteristics

Board type	PD2-DIO-128 PD2-DIO-128ST
Manufacturer	United Electronic Industries (UEI)
Bus type	PCI
Access method	Memory mapped
Multiple block instance support	No
Multiple board support	Yes

More About

- “Specifying UEI Boards” on page 53-3

External Websites

- www.ueidaq.com

UEI PD2-DIO-128 Digital Input

PD2-DIO-128 Digital Input block

Library

Simulink Real-Time Library for UEI

Scaling Input to Output

I/O Module Input	Block Output Data Type	Scaling
TTL	Double	TTL low = 0.0 TTL high = 1.0

Note

Note that each block of 16 ports must be input or output.

Block Parameters

Board type

Select the specific board type from the list provided.

Port (first channel of port)

From the list, select the first channel of the port. Each port is 16 bits. This value plus the **Channel vector** value appear on the terminal block.

Channel vector

Enter a vector of numbers to specify the input channels. For example, to use the first and third digital input channels, enter

```
[1 3]
```

The channel numbers can occur in arbitrary order. Number the channels beginning with 0, which is the same as the I/O module numbering.

Sample time

Enter the base sample time or a multiple of the base sample time (- 1 means sample time is inherited).

PCI slot (-1:autosearch)

If only one board of this type is in the target computer, enter - 1 to locate the board.

If two or more boards of this type are in the target computer, enter the bus number and the PCI slot number of the board associated with this driver block. Use the format **[BusNumber,SlotNumber]**.

To determine the bus number and the PCI slot number, type:

```
tg = slrt;  
getPCIInfo(tg, 'installed')
```

More About

- “Specifying UEI Boards” on page 53-3

External Websites

- www.ueidaq.com

UEI PD2-DIO-128 Digital Output

PD2-DIO-128 Digital Output block

Library

Simulink Real-Time Library for UEI

Scaling Input to Output

I/O Module Output	Block Input Data Type	Scaling
TTL	Double	< 0.5 = TTL low > 0.5 = TTL high

Block Parameters

Board type

Select the specific board type from the list provided.

Port (first channel of port)

From the list, select the first channel of the port. Each port is 16 bits. This value and the **Channel vector** value appear on the terminal block.

Channel vector

Enter a vector of numbers to specify the output channels. For example, to use the first and third digital output channels, enter

```
[1 3]
```

The channel numbers can occur in arbitrary order. Number the channels beginning with 0, which is the same as the numbering on the I/O module label.

Reset vector

The reset vector controls the behavior of the channel at model termination. Enter a scalar or a vector that is the same length as the channel vector. If you specify a scalar value, that setting is replicated over the channel vector. If you specify a value of 1,

the corresponding channel is reset to the value specified in the initial value vector. If you specify a value of 0, the channel remains at the last value attained while the model was running.

Initial value vector

The initial value vector contains the initial values (0 or 1) of the output channels. Enter a scalar or a vector that is the same length as the channel vector. If you enter a scalar, that value is replicated as the initial value over the channel vector. The channels are set to these initial values between the time the model is downloaded and the time it is started.

Sample time

Enter the base sample time or a multiple of the base sample time (- 1 means sample time is inherited).

PCI slot (-1:autosearch)

If only one board of this type is in the target computer, enter - 1 to locate the board.

If two or more boards of this type are in the target computer, enter the bus number and the PCI slot number of the board associated with this driver block. Use the format **[BusNumber, SlotNumber]**.

To determine the bus number and the PCI slot number, type:

```
tg = slrt;  
getPCIInfo(tg, 'installed')
```

More About

- “Specifying UEI Boards” on page 53-3

External Websites

- www.ueidaq.com

UEI PD2-DIO-128i

Support for the UEI PD2-DIO-128i Series I/O boards

Board Series

UEI PD2-DIO-128i

General Board Series

The PD2-DIO-128i series PCI boards have 64 opto-isolated digital input and 64 opto-isolated digital output ports in 16-bit ports.

The Simulink Real-Time block library supports this series of boards with these driver blocks:

- UEI PD2-DIO-128i Digital Input
- UEI PD2-DIO-128i Digital Output

Board Characteristics

Board type	PD2-DIO-128i
Manufacturer	United Electronic Industries (UEI)
Bus type	PCI
Access method	Memory mapped
Multiple block instance support	No
Multiple board support	Yes

More About

- “Specifying UEI Boards” on page 53-3

External Websites

- www.ueidaq.com

UEI PD2-DIO-128i Digital Input

PD2-DIO-128i Digital Input block

Library

Simulink Real-Time Library for UEI

Scaling Input to Output

I/O Module Input	Block Output Data Type	Scaling
TTL	Double	TTL low = 0.0 TTL high = 1.0

Block Parameters

Board type

Select the specific board type from the list provided.

Port (first channel of port)

From the list, select the first channel of the port. Each port is 16 bits. This value plus the **Channel vector** value appear on the terminal block.

The input and output ports on the PD2-DIO-128i are completely separate. You can use the same port numbers as input and output.

Channel vector

Enter a vector of numbers to specify the input channels. For example, to use the first and third digital input channels, enter

```
[1 3]
```

The channel numbers can occur in arbitrary order. Number the channels beginning with 0, which is the same as the numbering on the I/O module label.

Sample time

Enter the base sample time or a multiple of the base sample time (- 1 means sample time is inherited).

PCI slot (-1:autosearch)

If only one board of this type is in the target computer, enter - 1 to locate the board.

If two or more boards of this type are in the target computer, enter the bus number and the PCI slot number of the board associated with this driver block. Use the format [**BusNumber,SlotNumber**].

To determine the bus number and the PCI slot number, type:

```
tg = slrt;  
getPCIInfo(tg, 'installed')
```

More About

- “Specifying UEI Boards” on page 53-3

External Websites

- www.ueidaq.com

UEI PD2-DIO-128i Digital Output

PD2-DIO-128i Digital Output block

Library

Simulink Real-Time Library for UEI

Scaling Input to Output

I/O Module Output	Block Input Data Type	Scaling
TTL	Double	< 0.5 = TTL low > 0.5 = TTL high

Block Parameters

Board type

Select the specific board type from the list provided.

Port (first channel of port)

From the list, select the first channel of the port. Each port is 16 bits. This value and the **Channel vector** value appear on the terminal block.

The input and output ports on the PD2-DIO-128i are completely separate. You can use the same port numbers as input and output.

Channel vector

Enter a vector of numbers to specify the output channels. For example, to use the first and third digital output channels, enter

```
[1 3]
```

The channel numbers can occur in arbitrary order. Number the channels beginning with 0, which is the same as the numbering on the I/O module label.

Reset vector

The reset vector controls the behavior of the channel at model termination. Enter a scalar or a vector that is the same length as the channel vector. If you specify a scalar value, that setting is replicated over the channel vector. If you specify a value of 1, the corresponding channel is reset to the value specified in the initial value vector. If you specify a value of 0, the channel remains at the last value attained while the model was running.

Initial value vector

The initial value vector contains the initial values (0 or 1) of the output channels. Enter a scalar or a vector that is the same length as the channel vector. If you enter a scalar, that value is replicated as the initial value over the channel vector. The channels are set to these initial values between the time the model is downloaded and the time it is started.

Sample time

Enter the base sample time or a multiple of the base sample time (- 1 means sample time is inherited).

PCI slot (-1:autosearch)

If only one board of this type is in the target computer, enter - 1 to locate the board.

If two or more boards of this type are in the target computer, enter the bus number and the PCI slot number of the board associated with this driver block. Use the format **[BusNumber, SlotNumber]**.

To determine the bus number and the PCI slot number, type:

```
tg = slrt;  
getPCIInfo(tg, 'installed')
```

More About

- “Specifying UEI Boards” on page 53-3

External Websites

- www.ueidaq.com

UEI PDL-DIO-64

Support for the UEI PDL-DIO-64 Series I/O boards

Board Series

UEI PDL-DIO-64

General Board Series Description

The PDL-DIO-64 series PCI lab boards have 64 digital I/O channels in 16-bit ports, three counters/timers, two enhanced synchronous serial interface (ESSI) ports, and four high-speed (100 ns) IRQ lines.

The Simulink Real-Time block library supports this series of boards with these driver blocks:

- UEI PDL-DIO-64 Digital Input
- UEI PDL-DIO-64 Digital Output

The Simulink Real-Time software only supports the digital I/O channels for this board series. It does not support the additional functionality.

Board Characteristics

Board type	PDL-DIO-64 PDL-DIO-64ST PDL-DIO-64CT PDL-DIO-64TS
Manufacturer	United Electronic Industries (UEI)
Bus type	PCI
Access method	Memory mapped
Multiple block instance support	No
Multiple board support	Yes

More About

- “Specifying UEI Boards” on page 53-3

External Websites

- www.ueidaq.com

UEI PDL-DIO-64 Digital Input

PDL-DIO-64 Digital Input block

Library

Simulink Real-Time Library for UEI

Scaling Input to Output

I/O Module Input	Block Output Data Type	Scaling
TTL	Double	TTL low = 0.0 TTL high = 1.0

Note

Note that each block of 16 ports must be input or output.

Block Parameters

Board type

Select the specific board type from the list provided.

Port (first channel of port)

From the list, select the first channel of the port. Each port is 16 bits. This value plus the **Channel vector** value appear on the terminal block.

Channel vector

Enter a vector of numbers to specify the input channels. For example, to use the first and third digital input channels, enter

```
[1 3]
```

The channel numbers can occur in arbitrary order. Number the channels beginning with 0, which is the same as the numbering on the I/O module label.

Sample time

Enter the base sample time or a multiple of the base sample time (- 1 means sample time is inherited).

PCI slot (-1:autosearch)

If only one board of this type is in the target computer, enter - 1 to locate the board.

If two or more boards of this type are in the target computer, enter the bus number and the PCI slot number of the board associated with this driver block. Use the format **[BusNumber,SlotNumber]**.

To determine the bus number and the PCI slot number, type:

```
tg = slrt;  
getPCIInfo(tg, 'installed')
```

More About

- “Specifying UEI Boards” on page 53-3

External Websites

- www.ueidaq.com

UEI PDL-DIO-64 Digital Output

PDL-DIO-64 Digital Output block

Library

Simulink Real-Time Library for UEI

Scaling Input to Output

I/O Module Output	Block Input Data Type	Scaling
TTL	Double	< 0.5 = TTL low > 0.5 = TTL high

Block Parameters

Board type

Select the specific board type from the list provided.

Port (first channel of port)

From the list, select the first channel of the port. Each port is 16 bits. This value and the **Channel vector** value appear on the terminal block.

Channel vector

Enter a vector of numbers to specify the output channels. For example, to use the first and third digital output channels, enter

```
[1 3]
```

The channel numbers can occur in arbitrary order. Number the channels beginning with 0, which is the same as the numbering on the I/O module label.

Reset vector

The reset vector controls the behavior of the channel at model termination. Enter a scalar or a vector that is the same length as the channel vector. If you specify a scalar value, that setting is replicated over the channel vector. If you specify a value of 1,

the corresponding channel is reset to the value specified in the initial value vector. If you specify a value of 0, the channel remains at the last value attained while the model was running.

Initial value vector

The initial value vector contains the initial values (0 or 1) of the output channels. Enter a scalar or a vector that is the same length as the channel vector. If you enter a scalar, that value is replicated as the initial value over the channel vector. The channels are set to these initial values between the time the model is downloaded and the time it is started.

Sample time

Enter the base sample time or a multiple of the base sample time (- 1 means sample time is inherited).

PCI slot (-1:autosearch)

If only one board of this type is in the target computer, enter - 1 to locate the board.

If two or more boards of this type are in the target computer, enter the bus number and the PCI slot number of the board associated with this driver block. Use the format **[BusNumber, SlotNumber]**.

To determine the bus number and the PCI slot number, type:

```
tg = slrt;  
getPCIInfo(tg, 'installed')
```

More About

- “Specifying UEI Boards” on page 53-3

External Websites

- www.ueidaq.com

UEI PDXI-DIO-64

Support for the UEI PDXI-DIO-64 Series I/O boards

Board Series

UEI PDXI-DIO-64

General Board Series Description

The PDXI-DIO-64 series PXI boards have 64 digital I/O channels in 16-bit ports, three counters/timers, two enhanced synchronous serial interface (ESSI) ports, and four high-speed (100 ns) IRQ lines.

The Simulink Real-Time block library supports this series of boards with these driver blocks:

- UEI PDXI-DIO-64 Digital Input
- UEI PDXI-DIO-64 Digital Output

The Simulink Real-Time software only supports the digital I/O channels for this board series. It does not support the additional functionality.

Board Characteristics

Board type	PDXI-DIO-64 PDXI-DIO-64ST PDXI-DIO-64CT PDXI-DIO-64TS
Manufacturer	United Electronic Industries (UEI)
Bus type	CompactPCI, PXI
Access method	Memory mapped
Multiple block instance support	No
Multiple board support	Yes

More About

- “Specifying UEI Boards” on page 53-3

External Websites

- www.ueidaq.com

UEI PDXI-DIO-64 Digital Input

PDXI-DIO-64 Digital Input block

Library

Simulink Real-Time Library for UEI

Scaling Input to Output

I/O Module Input	Block Output Data Type	Scaling
TTL	Double	TTL low = 0.0 TTL high = 1.0

Note

Note that each block of 16 ports must be input or output.

Block Parameters

Board type

Select the specific board type from the list provided.

Port (first channel of port)

From the list, select the first channel of the port. Each port is 16 bits. This value plus the **Channel vector** value appear on the terminal block.

Channel vector

Enter a vector of numbers to specify the input channels. For example, to use the first and third digital input channels, enter

```
[1 3]
```

The channel numbers can occur in arbitrary order. Number the channels beginning with 0, which is the same as the numbering on the I/O module label.

Sample time

Enter the base sample time or a multiple of the base sample time (- 1 means sample time is inherited).

PCI slot (-1:autosearch)

If only one board of this type is in the target computer, enter - 1 to locate the board.

If two or more boards of this type are in the target computer, enter the bus number and the PCI slot number of the board associated with this driver block. Use the format **[BusNumber,SlotNumber]**.

To determine the bus number and the PCI slot number, type:

```
tg = slrt;  
getPCIInfo(tg, 'installed')
```

More About

- “Specifying UEI Boards” on page 53-3

External Websites

- www.ueidaq.com

UEI PDXI-DIO-64 Digital Output

PDXI-DIO-64 Digital Output block

Library

Simulink Real-Time Library for UEI

Scaling Input to Output

I/O Module Output	Block Input Data Type	Scaling
TTL	Double	< 0.5 = TTL low > 0.5 = TTL high

Block Parameters

Board type

Select the specific board type from the list provided.

Port (first channel of port)

From the list, select the first channel of the port. Each port is 16 bits. This value and the **Channel vector** value appear on the terminal block.

Channel vector

Enter a vector of numbers to specify the output channels. For example, to use the first and third digital output channels, enter

```
[1 3]
```

The channel numbers can occur in arbitrary order. Number the channels beginning with 0, which is the same as the numbering on the I/O module label.

Reset vector

The reset vector controls the behavior of the channel at model termination. Enter a scalar or a vector that is the same length as the channel vector. If you specify a scalar value, that setting is replicated over the channel vector. If you specify a value of 1,

the corresponding channel is reset to the value specified in the initial value vector. If you specify a value of 0, the channel remains at the last value attained while the model was running.

Initial value vector

The initial value vector contains the initial values (0 or 1) of the output channels. Enter a scalar or a vector that is the same length as the channel vector. If you enter a scalar, that value is replicated as the initial value over the channel vector. The channels are set to these initial values between the time the model is downloaded and the time it is started.

Sample time

Enter the base sample time or a multiple of the base sample time (- 1 means sample time is inherited).

PCI slot (-1:autosearch)

If only one board of this type is in the target computer, enter - 1 to locate the board.

If two or more boards of this type are in the target computer, enter the bus number and the PCI slot number of the board associated with this driver block. Use the format **[BusNumber, SlotNumber]**.

To determine the bus number and the PCI slot number, type:

```
tg = slrt;  
getPCIInfo(tg, 'installed')
```

More About

- “Specifying UEI Boards” on page 53-3

External Websites

- www.ueidaq.com

UEI PDXI-AO Series

Support for the UEI PDXI-AO Series I/O boards

Board Series

UEI PDXI-AO Series

General Board Series Description

The PDXI-AO series boards have 8, 16, or 32 analog output (D/A) channels (16 bit) with a maximum sampling rate of 100 kHz per channel. They also have 8 digital input lines, and 8 digital output lines.

The Simulink Real-Time block library supports this series of boards with these driver blocks:

- UEI PDXI-AO Analog Output (D/A)
- UEI PDXI-AO Digital Input
- UEI PDXI-AO Digital Output

Board Characteristics

Board type	PDXI-AO-8/16 PDXI-AO-16/16 PDXI-AO-32/16 PDXI-AO-96/16
Manufacturer	United Electronic Industries (UEI)
Bus type	CompactPCI, PXI
Access method	Memory mapped
Multiple block instance support	No
Multiple board support	Yes

More About

- “Specifying UEI Boards” on page 53-3

External Websites

- www.ueidaq.com

UEI PDXI-AO Analog Output (D/A)

PDXI-AO Analog Output block

Library

Simulink Real-Time Library for UEI

Scaling Input to Output

I/O Module Output	Block Input Data Type	Scaling
Volts	Double	1

Block Parameters

Board type

Select the specific board type from the list provided.

Channel vector

Enter a vector of numbers to specify the output channels between 1 and 16. For example, to use the first and second analog output (D/A) channels, enter

```
[1 2]
```

The channel numbers can occur in arbitrary order. Number the channels beginning with 1 even if this board manufacturer numbers them beginning with 0. The maximum allowable channel number for PD2-AO and PDXI-AO series boards is 8, 16, 32, or 96 depending on the specific board type. For other board series, the maximum channel number is 2.

Reset vector

The reset vector must be the same length as the channel vector. It contains values of 0 or 1. This parameter controls the behavior at model termination. A value of 1 causes the corresponding channel to be reset to the value specified in the initial value vector. A value of 0 causes the channel to remain at the last value attained while the model was running.

Initial value vector

The initial value vector must be the same length as the channel vector and should contain the initial voltage values for the output channels. The channels are set to these values between the time the model is downloaded and the time it is started.

Sample time

Enter the base sample time or a multiple of the base sample time (- 1 means sample time is inherited).

PCI slot (-1:autosearch)

If only one board of this type is in the target computer, enter - 1 to locate the board.

If two or more boards of this type are in the target computer, enter the bus number and the PCI slot number of the board associated with this driver block. Use the format [**BusNumber,SlotNumber**].

To determine the bus number and the PCI slot number, type:

```
tg = slrt;  
getPCIInfo(tg, 'installed')
```

More About

- “Specifying UEI Boards” on page 53-3

External Websites

- www.ueidaq.com

UEI PDXI-AO Digital Input

PDXI-AO Digital Input block

Library

Simulink Real-Time Library for UEI

Scaling Input to Output

I/O Module Input	Block Output Data Type	Scaling
TTL	Double	TTL low = 0.0 TTL high = 1.0

Block Parameters

Board type

Select the specific board type from the list provided.

Channel vector

Enter a vector of numbers to specify the input channels. For example, to use the first and third digital input channels, enter

```
[1 3]
```

The channel numbers can occur in arbitrary order. Number the channels beginning with 1 even if this board manufacturer numbers them beginning with 0. The maximum allowable channel number is 16 except for the PD2-AO and PDXI-AO series. For those boards, the maximum channel number is 8.

Sample time

Enter the base sample time or a multiple of the base sample time (-1 means sample time is inherited).

PCI slot (-1:autosearch)

If only one board of this type is in the target computer, enter -1 to locate the board.

If two or more boards of this type are in the target computer, enter the bus number and the PCI slot number of the board associated with this driver block. Use the format **[BusNumber,SlotNumber]**.

To determine the bus number and the PCI slot number, type:

```
tg = slrt;  
getPCIInfo(tg, 'installed')
```

More About

- “Specifying UEI Boards” on page 53-3

External Websites

- www.ueidaq.com

UEI PDXI-AO Digital Output

PDXI-AO Digital Output block

Library

Simulink Real-Time Library for UEI

Scaling Input to Output

I/O Module Output	Block Input Data Type	Scaling
TTL	Double	< 0.5 = TTL low > 0.5 = TTL high

Block Parameters

Board type

Select the specific board type from the list provided.

Channel vector

Enter a vector of numbers to specify the output channels. For example, to use the first and third digital output channels, enter

```
[1 3]
```

The channel numbers can occur in arbitrary order. Number the channels beginning with 1 even if this board manufacturer numbers them beginning with 0. The maximum allowable channel number is 16, except for the PD2-AO and PDXI-AO series. For those boards, the maximum channel number is 8.

Reset vector

The reset vector must be the same length as the channel vector. It contains values of 0 or 1. This parameter controls the behavior at model termination. A value of 1 causes the corresponding channel to be reset to the value specified in the initial value vector. A value of 0 causes the channel to remain at the last value attained while the model was running.

Initial value vector

The initial value vector must be the same length as the channel vector. It contains the initial values (0 or 1) for the output channels. The channels are set to these values between the time the model is downloaded and the time it is started.

Sample time

Enter the base sample time or a multiple of the base sample time (- 1 means sample time is inherited).

PCI slot (-1:autosearch)

If only one board of this type is in the target computer, enter - 1 to locate the board.

If two or more boards of this type are in the target computer, enter the bus number and the PCI slot number of the board associated with this driver block. Use the format [**BusNumber,SlotNumber**].

To determine the bus number and the PCI slot number, type:

```
tg = slrt;  
getPCIInfo(tg, 'installed')
```

More About

- “Specifying UEI Boards” on page 53-3

External Websites

- www.ueidaq.com

Versallogic: Board and Blocks

This topic describes the Versallogic I/O board and blocks supported by the Simulink Real-Time product (www.versallogic.com).

Versallogic VSBC-6

Versallogic VSBC-6 Analog Input (A/D)

Versallogic VSBC-6 Digital Input

Versallogic VSBC-6 Digital Output

Versallogic VSBC-6 Watchdog

Versallogic VSBC-6

Support for Versallogic VSBC-6 single-board computer

Board

Versallogic VSBC-6

General Description

The VSBC-6 is a single board computer with 8 signal ended analog input (A/D) channels, 16 digital I/O lines, and a watchdog timer.

The Simulink Real-Time block library supports this board with these driver blocks:

- Versallogic VSBC-6 Analog Input (A/D)
- Versallogic VSBC-6 Digital Input
- Versallogic VSBC-6 Digital Output
- Versallogic VSBC-6 Watchdog

Board Characteristics

Board type	VSBC-6
Manufacturer	Versallogic
Bus type	N/A
Access method	N/A
Multiple block instance support	Yes
Multiple board support	No

External Websites

- www.versallogic.com

Versallogic VSBC-6 Analog Input (A/D)

VSBC-6 Analog Input block

Library

Simulink Real-Time Library for Versallogic

Block Parameters

Channel vector

Enter numbers between 1 and 8. This driver allows you to enter channel numbers in arbitrary order.

For example, to use the first, second, and fifth channels, enter

[1,2,5]

Number the channels beginning with 1 even if this board manufacturer starts numbering the channels with 0.

Range vector

Enter a range code for each of the channels in the channel vector. The range vector must be the same length as the channel vector. This driver allows each channel to be different.

The following table is a list of the ranges for this driver and the corresponding range codes.

Input Range (V)	Range Code
-10 to +10	-10
-5 to +5	-5
0 to +10	10
0 to +5	5

For example, if the first channel is -10 to +10 volts and the second and fifth channels are 0 to +5 volts, enter

[-10,5,5]

Sample time

Enter the base sample time or a multiple of the base sample time (-1 means sample time is inherited).

External Websites

- www.versalogic.com

Versalogic VSBC-6 Digital Input

VSBC-6 Digital Input block

Library

Simulink Real-Time Library for Versalogic

Scaling Input to Output

Hardware Input	Block Output Data Type	Scaling
TTL	Double	TTL low = 0.0 TTL high = 1.0

Block Parameters

Channel vector

Enter a numbers between 1 and 16 to select the number of digital input lines used. This driver allows the selection of individual digital input lines in arbitrary order. Each group of eight lines (1 to 8 or 9 to 16) can be only input or output. For example, if one bit in the range 1 to 8 is an input line, lines 1 to 8 must be input lines.

For example, to use the first, second and fifth digital input lines, enter

```
[1,2,5]
```

Number the lines beginning with 1, even if this board manufacturer starts numbering the lines with 0.

Sample time

Enter the base sample time or a multiple of the base sample time (- 1 means sample time is inherited).

External Websites

- www.versalogic.com

Versallogic VSBC-6 Digital Output

VSBC-6 Digital Output block

Library

Simulink Real-Time Library for Versallogic

Scaling Input to Output

Hardware Output	Block Input Data Type	Scaling
TTL	Double	< 0.5 = TTL low ± 0.5 = TTL high

Block Parameters

Channel vector

Enter numbers between 1 and 16 to select the number of digital output lines used. This driver allows the selection of individual digital output lines in arbitrary order. Each group of eight lines can only be input or output. Each group of eight lines (1 to 8 or 9 to 16) can be only input or output. For example, if one bit in the range 1 to 8 is an output line, lines 1 to 8 must be output lines.

For example, to use the first, second and fifth digital output lines, enter

[1,2,5]

Number the lines beginning with 1, even if this board manufacturer starts numbering the lines with 0.

Sample time

Enter the base sample time or a multiple of the base sample time (-1 means sample time is inherited).

External Websites

- www.versallogic.com

Versalogic VSBC-6 Watchdog

VSBC-6 Watchdog block

Library

Simulink Real-Time Library for Versalogic

Block Parameters

Show enable port

Select this check box to show a digital input port on the driver block. This port indicates that the watchdog timer is enabled. The watchdog timer starts in a disabled state. If you want to use the VSBC-6 board to restart the system when a programmable timeout occurs, select this check box.

Show reset port

Select this check box to show a digital input port on the driver block. A signal connected to this port resets the watchdog whenever its value exceeds 1.

Sample time

Enter the base sample time or a multiple of the base sample time (- 1 means sample time is inherited).

External Websites

- www.versalogic.com

Asynchronous Events

Asynchronous Event Support

In this section...
“Adding an Asynchronous Event” on page 56-2
“Asynchronous Interrupt Examples” on page 56-4

Adding an Asynchronous Event

The Simulink Real-Time software includes support for asynchronous events in response to an interrupt from I/O boards. In response to these interrupts, the CPU can suspend normal execution and jump to another section of code called an Interrupt Service routine (ISR).

When developing an Simulink Real-Time model, you can model an Interrupt Server Routine (ISR) by using a Function-Call Subsystem. Additionally, add an IRQ Source block connected to the Function-Call Subsystem block. This subsystem is then executed when an interrupt occurs and the CPU is ready to accept it.

After you install an I/O board with interrupt support into your target computer, you can add Simulink Real-Time asynchronous blocks to your Simulink model.

- 1 In the MATLAB Command Window, type

```
slrtlib
```

The Simulink Real-Time Library opens.

- 2 Double-click the Asynchronous Event group block.

The Library: slrtlib/Asynchronous Event window opens.

- 3 Drag the Simulink Real-Time IRQ block into your Simulink model and connect the output to this block to the input of a Function-Call Subsystem. For more information on Function-Call subsystems, see the Simulink and Simulink Coder documentation.

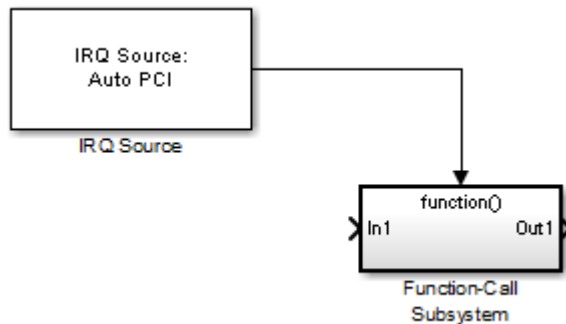

In the setup shown above, the CPU executes the contents of the Function Call-Subsystem whenever IRQ 5 occurs.

- 4 Double-click the IRQ Source block.

The Block Parameters: IRQ Source dialog box opens.

- 5 To determine and use the IRQ that the BIOS assigned to the board, from the **IRQ line number** list, choose **Auto (PCI only)**.

Alternatively, choose one of the values 3–15 for this number. To determine the available IRQ line numbers on the target computer, use the function `SimulinkRealTime.target.getPCIInfo`.

- 6 From the **I/O board generating the interrupt** drop-down list, select an interrupt board.
- 7 In the **PCI slot (-1: autosearch) or ISA base address** field, enter the PCI slot number or enter -1 to let the Simulink Real-Time software determine the number.
- 8 Click **OK**.

For more information about the IRQ Source block, see [Async IRQ Source](#).

To transfer data from your ISR, add an Async Transition Block or Async Read/Write blocks to your Simulink model. See [Async Rate Transition](#), [Async Buffer Write and Read](#), and “Asynchronous Interrupt Examples” on page 56-4.

If you are using a CAN field bus with interrupts, see “Asynchronous Interrupt Examples” on page 56-4.

Asynchronous Interrupt Examples

The Simulink Real-Time software provides several example models. If you installed the MATLAB software in the default location, these models are located here:

```
C:\MATLAB\toolbox\rtw\targets\xpc\xpcdemos
```

To access these models, in the MATLAB Command Window, type the name of the model. Each model contains annotations documenting its purpose, and serves as an example of how to use these blocks.

- `xpcasynbuffer` — Model using an external TTL signal to trigger and interrupt on the parallel port. Data exchange between an asynchronous task and a monotonic task using Async Buffer Read /Write blocks.
- `xpcasynctrans` — Model using an external TTL signal to trigger and interrupt on the parallel port. Data exchange between an asynchronous task and a rate monotonic task using an Async Rate Transition block.
- `xpccanintpc104` — Model using interrupt driven CAN I/O communication with the CAN-AC2-104 board.
- `xpccanintpci` — Model using interrupt driven CAN I/O communication with the CAN-AC2-PCI board.

Asynchronous Event: Blocks

This topic describes Simulink Real-Time Target Management library and Displays and Logging library blocks:

Async Buffer Write and Read

Async Buffer Write and Read blocks

Library

Simulink Real-Time Library for Asynchronous Event

Description

These blocks provide double buffering of data between the ISR and the model which executes rate-monotonically in real time. Use these blocks in pairs with an Async Buffer Write Block leading into an Async Buffer Read block. The Async Buffer Write Block has to be part of the ISR, and the Async Buffer Read block is outside the ISR.

Unlike the rate transition block, Async Buffer Write and Read blocks do not copy data from one buffer to another. Instead, the software disables interrupts and swaps buffer pointers. This method disables interrupts for a shorter time than the rate transition block and protects against data corruption caused by overwriting partially copied buffers.

Block Parameters

Sample time

Enter the base sample time or a multiple of the base sample time (- 1 means sample time is inherited).

See Also

“Asynchronous Event Support” on page 56-2

Async IRQ Source

Async IRQ Source block

Library

Simulink Real-Time Library for Asynchronous Event

Description

The `IRQ Source` block configures the Simulink and Simulink Real-Time software to treat a particular `Function-Call Subsystem` as an Interrupt Service Routine (ISR). This block is actually a virtual block and does not exist at model execution time. However, the model initialization code sets up the CPU to execute the ISR when the specified interrupt occurs.

Block Parameters

IRQ line number

Select `Auto (PCI only)` to enable the Simulink Real-Time software to automatically determine the IRQ that the BIOS assigned to the board and use it.

Alternatively, select the IRQ line number you are using for this block. This depends on the characteristics of your I/O module. You may need to query the PCI bus in the target computer to find what IRQ the PCI bus assigned to your I/O module. Use the function `SimulinkRealTime.target.getPCIInfo`.

Valid IRQ numbers are between 3 and 15.

I/O board generating the interrupt

For many I/O boards, you need to set up the board to generate the interrupt. You might also need to set up board specific features at the beginning and/or end of an ISR. Select the board you intend to use from the drop-down list.

PCI slot (-1: autosearch) or ISA base address

- If PCI:

If only one board of this type is in the target computer, enter - 1 to automatically locate the board.

If two or more boards of this type are in the target computer, enter the bus number and the PCI slot number of the board associated with this driver block. Use the format [BusNumber, SlotNumber]. To determine the bus number and the PCI slot number, type:

```
tg = slrt;  
getPCIInfo(tg, 'installed')
```

- If ISA, enter the base address.

See Also

“Asynchronous Event Support” on page 56-2

Async Rate Transition

Async Rate Transition block

Library

Simulink Real-Time Library for Asynchronous Event

Description

Use the `Asynchronous Rate Transition` block to double buffer data between the function call subsystem and the rest of the model, which executes rate-monotonically in real time.

Normally, the interrupt service routine writes to the first buffer. When the next model step executes, the first buffer is copied to the second buffer and its value is used for model calculations.

If a second interrupt occurs while the buffer is being copied, data is corrupted. The CPU copies part of the data from the first buffer. When the second interrupt occurs, it writes over the entire first buffer. When the CPU returns from the second interrupt, it continues the copy operation from the first buffer, which contains data written during the second interrupt.

To prevent data corruption, use `Async Buffer Write` and `Read` blocks.

Block Parameters

Sample time

Enter the base sample time or a multiple of the base sample time (-1 means sample time is inherited).

See Also

“Asynchronous Event Support” on page 56-2

Utility Drivers, Target Management, Displays and Logging

Utility Blocks

The Simulink Real-Time utility blocks support utility functions. Some of these blocks exist in the Utilities library, available at the top level of the Simulink Real-Time Block Library. Others are available as sublibraries of the I/O function they support. For example, the `Rollover Counter` block is located in the Incremental Encoder/Utilities sublibrary.

Bit Packing

Construct data frames

Library

Simulink Real-Time Library for Utilities

Description

This block constructs data frames. Its output port is typically connected to an input port of a Send block or Digital Output block. The block has one output port. This port can be a vector of arbitrary size; it represents the data frame entity constructed by the signals entering the block at its input ports. The number of input ports depends on the setting in the block dialog box.

Block Parameters

Bit Patterns

Specify bit patterns. The data type entered in the control must be a MATLAB cell array vector. The number of elements in the cell array define the number of input ports shown by this block instance. The cell array elements must be of type double array and define the position of each bit of the incoming value (data typed input port) in the outgoing double value (data frame). From a data type perspective (input ports), the block behaves like a Simulink Sink block, and therefore the data types of the input ports are inherited from the driving blocks.

Output port (packed) data type

From the list, select an output port (packed) data type.

- double
- single
- int8
- uint8
- int16

- uint16
- int32
- uint32
- boolean

Output port (packed) dimensions

Specify the dimensions the output port (packed). Enter this as a vector. Specify the size of the port using a format compatible with the MATLAB `size` command.

Bit Unpacking

Deconstruct data frames

Library

Simulink Real-Time Library for Utilities

Description

This block is used to extract data frames. Its input port is typically connected to an output port of a Receive block or Digital Input block.

The block has one input port, which represents the data frame entity from which the signals are extracted and leaving the block at its output ports. The number of output ports and the data type of each output port depend on the settings in the block dialog box.

Block Parameters

Bit Patterns

Specify bit patterns. The data type must be a MATLAB cell array vector. The number of elements in the cell array define the number of input ports shown by this block instance. The cell array elements must be of type double array and define the position of each bit of the incoming value (data typed input port) in the outgoing double value (data frame). From a data type perspective, the block behaves like a Sink block. The **Input port (packed) data types** specify the data type of the input port.

Input port (packed) data types

From the list, select an input port (packed) data type.

- double
- single
- int8

- `uint8`
- `int16`
- `uint16`
- `int32`
- `uint32`
- `boolean`

Input port (packed) dimension

Specify the dimensions of the input port (packed). Enter this as a vector. Specify the size of the port using a format compatible with the MATLAB `size` command.

Output port (unpacked) data types (cell array)

The output ports (packed) can be of arbitrary data type. The number of elements in the cell array define the number of output ports shown by this block instance. The data types can be

- `double`
- `single`
- `int8`
- `uint8`
- `int16`
- `uint16`
- `int32`
- `uint32`
- `boolean`

Output port (unpacked) dimension (cell array)

Specify the dimensions of each output port (unpacked). Enter this as a cell array of vector sizes.

Sign extend

Select this check box to enable sign extension. If you select this check box and unpack the data frame into a signed type (`int8`, `int16`, or `int32`), the block performs sign extension. For example, if the bit pattern is `[0:4]`, and the data type is `int8`, you are extracting 5 bits into an 8-bit wide signed type. In this case, bits 5, 6, and 7 are the same as bit 4, resulting in sign extension. This functionality enables you to pack and unpack negative numbers without losing precision.

Byte Packing

Construct data frames

Library

Simulink Real-Time Library for Utilities

Description

The **Byte Packing** block converts one or more Simulink signals of user-selectable data types to a single vector of varying data types. The output of this block typically connects to an input port of a **Send** block.

To specify packing density as required by your application, use the **Byte Alignment** parameter . If the model accesses the data items frequently, consider selecting an alignment value equal to the largest data type that you want to access. If the model transfers the data items frequently as a group, consider selecting an alignment value of 1, which packs the data into as small a space as possible.

Block Parameters

Output port (packed) data type

Specify the data type for the different signals. The block determines the sizes of the signals. From the list, select an output port (packed) data type.

- double
- single
- int8
- uint8
- int16
- uint16
- int32
- uint32

- `boolean`

Inport port (unpacked) data types (cell array)

Specify the data types of the input ports (unpacked) for the different signals as part of the block parameters.

- `double`
- `single`
- `int8`
- `uint8`
- `int16`
- `uint16`
- `int32`
- `uint32`
- `boolean`

The data type must be a MATLAB cell array vector. The number of elements in the cell array define the number of input ports shown by this block instance.

Byte Alignment

In the byte alignment field, you specify how the input signal data types are aligned after packing. The possible values are 1, 2, 4, and 8. Each element in the input signals list starts at a multiple of the alignment value, specified from the start of the vector.

If the alignment value is larger than the size of the data type in bytes, the block adds pad bytes of value 0 to fill the space. For example, if the alignment value is 4, a `uint32` receives no padding, a `uint16` receives 2 bytes of padding, and a `uint8` receives 3 bytes of padding.

Byte Reversal/Change Endianess

Reverse little-endian data for big-endian processor

Library

Simulink Real-Time Library for Utilities

Description

You use the Byte Reversal/Change Endianess block for communication between a Simulink Real-Time system and a system running with a processor that is *big-endian*. Processors compatible with the Intel 80x86 family are *little-endian*. For this situation, insert a Byte Reversal/Change Endianess block before the Pack block and another just after the Unpack block. The following is the Change Endianess block.

Block Parameters for Change Endianess

Number of input ports

The number of input ports adjusts automatically to follow this parameter, and the number of outputs is equal to the number of inputs.

Machine word length

Select one of the following machine word lengths to which to convert the data:

- Byte
- Word
- Double Word

The following is the Byte Reversal block.

Byte Reversal Block Parameters

Number of inputs

The number of input ports adjusts automatically to follow this parameter, and the number of outputs is equal to the number of inputs.

Byte Unpacking

Deconstruct data frames

Library

Simulink Real-Time Library for Utilities

Description

This block is the exact analog of the Pack block. It can receive a vector of one of the following types:

- double
- single
- int8
- uint8
- int16
- uint16
- int32
- uint32
- boolean

It outputs various Simulink data types in different sizes.

Block Parameters

Output port (unpacked) data types (cell array)

The output ports (unpacked) can be of arbitrary data type. The number of elements in the cell array define the number of output ports shown by this block instance. The data types can be

- double

- single
- int8
- uint8
- int16
- uint16
- int32
- uint32
- boolean

Output port (unpacked) dimensions (cell array)

Specify the dimensions of each output port (unpacked). Enter this as a cell array of vector sizes.

Byte Alignment

The byte alignment field specifies how the data types are aligned. The possible values are 1, 2, 4, and 8. Each element in the list of signals starts on a boundary specified by the alignment relative to the start of the vector.

Extended Counter

Extended Counter sample block

Library

Simulink Real-Time Library for Rollover

Description

This block outputs a count not limited to the number of bits on the board encoder counter register. It receives as input the output of an encoder block.

Block Parameters

Rollover Counts

Enter the number of rollover counts. This is the number at which the rollover occurs. This value should normally be 2^n , where n is the number of bits in the encoder counter register. Each rollover equals this number.

Encoder Starting Value

Enter the starting value with which the encoder block begins. This value should match the value in the encoder mask.

Rollover Threshold

Enter a rollover threshold value. This subsystem infers when a rollover occurs by comparing successive outputs from an encoder block. When the difference between outputs is extremely large, a rollover has occurred. Enter a value that is

- Larger than the worst-case difference between successive outputs (to prevent declaring a rollover when it was just a large step)
- Less than the maximum count value minus the worst-case difference (to prevent missing a rollover)

Ideally, enter the value $2^{(n-1)}$, where n is the number of bits in the encoder counter register. The default is 2^{15} .

See Also

Rollover Counter

Rollover Counter

Rollover Counter sample block

Library

Simulink Real-Time Library for Rollover

Description

This block counts the number of times the output of an encoder block has rolled over. It counts up for positive direction rollovers and down for negative direction rollovers.

Block Parameters

Encoder Starting Value

Enter the starting value you want the encoder block to begin with. Match this value to the value in the encoder mask.

Rollover Threshold

Enter a rollover threshold value. To determine when a rollover has occurred, the model compares two consecutive encoder outputs and looks for a large jump. A large jump indicates a register overflow.

The threshold you enter defines a large jump. The smaller the threshold, the more likely the model will misinterpret a jump in successive encoder counts as a rollover. The larger the threshold, the more likely the model will not detect a rollover. Ideally, choose a number that is half the size of the register (for example, $2^{(n-1)}$), where n is the size of the register in bits.

See Also

Extended Counter

Shared Memory Pack

Shared memory pack

Library

Simulink Real-Time Library for Shared Memory

Description

This block packs the specified partition structure into an unstructured double word array vector. It converts one or more Simulink signals of varying data types into the vector. Typically, the input to a pack block is the output from a write block. The Simulink interface is not aware of structures; pass the output of each structure segment as input to the Shared Memory Pack block.

Memory partitions consist of groups of Simulink signals, which are combined into blocks (packets) of 32-bit words. Before you begin to configure this block, be sure that you have a predefined shared memory partition structure as required by the shared memory manufacturer.

This block ignores the **Address** field of the partition structure.

Block Parameters

Partition struct

Enter the name of the predefined shared memory partition structure.

See Also

Shared Memory Unpack

“GE Fanuc Embedded Systems (VMIC)”

“SBS Broadcast Memory”

“Systran”

Shared Memory Unpack

Shared memory unpack

Library

Simulink Real-Time Library for Shared Memory

Description

This block unpacks an unstructured double word array vector (from the Shared Memory Pack block) into the specified partition structure.

Before you begin to configure this block, be sure that you have a predefined shared memory partition structure as required by the shared memory manufacturer.

This block ignores the **Address** field of the partition structure.

Block Parameters

Partition struct

Enter the name of the predefined shared memory partition structure. The block unpacks the double word array vector into this structure.

See Also

Shared Memory Pack

“GE Fanuc Embedded Systems (VMIC)”

“SBS Broadcast Memory”

“Systran”

Target Management, Display, and Logging Blocks

From File

Read data from file on target computer

Library

Simulink Real-Time Library for Target Management

Description

The **From File** block reads data from a file on the target computer hard disk and outputs that data in chunks every sample time. As the Simulink Real-Time kernel on the target computer reads the file data, it writes that data into a software buffer whose size is user-defined. The **From File** block then reads the data from this buffer and propagates it to the block outputs for use by the real-time application. For example, use the **From File** block to drive a model with externally acquired data (data from a file).

The **From File** block distributes the data as a sequence of bytes. To use these data bytes as input to a model, convert the data into one or more signals. To do so, use the **Byte Unpacking** block. This block outputs data in various Simulink data types. For example, assume that data in your file represents a single precision scalar and a double precision vector of width 3. To convert data of this type, set up the block to output every sample time:

```
28 bytes (1 * sizeof('single') + 3 * sizeof('double'))
```

This data can then be converted into signal values by the **Byte Unpacking** block.

See the following topics:

- “File Format” on page 59-3 — Describes the target computer source file format
- “Block Parameters” on page 59-4 — Describes the block parameters for the **From File** block

File Format

Before you use a target computer file as the source for the **From File** block, format the data in the file. The file format is a concatenation of the different data elements for one time step, followed by the next time step, and so on.

For example, assume that your file contains the data from the preceding example. Assign a variable to each component, for example,

- **a** — single precision value
- **b** — double precision vector of 3

Assume, also, that there are **N** time steps worth of data. The array dimension for **a** and **b** are then

- `size(a)` — [1, N]
- `size(b)` — [3, N]

In sequence, write out the data like the following to create the file.

```
a(1, 1)    4 bytes
b(:, 1)   24 bytes
a(1, 2)    4 bytes
b(:, 2)   24 bytes
...
...
a(1, N)    4 bytes
b(:, N)   24 bytes
```

If you already have the data as MATLAB variables, use the `SimulinkRealTime.utils.bytes2file` function to create the file on the development computer. This function has the following syntax:

```
SimulinkRealTime.utils.bytes2file(filename, var1, ... varn)
```

where

- **filename** — Specify the name of the data file from which the **From File** block distributes data
- **var1, ... varn** — Specify the column of data to be output to the model.

You can then use `SimulinkRealTime.copyFileToTarget` to download the file to the target computer.

Block Parameters

Filename

Enter the name of the target computer file that contains the data.

Output port width

Enter the size, in bytes, of the data to be distributed each sample time.

Buffer size

Enter the size of the software FIFO, in bytes. The Simulink Real-Time kernel fills this FIFO with the data to be input to the model. The From File block empties this FIFO as it inputs the data to the model.

This parameter should ideally be

- Much larger than **Output port width**
- At least several times the disk read size

Increasing this parameter value helps prevent the real-time application from emptying the buffer faster than the background task can fill it. This can happen if you have multitasking models or conditionally executed subsystems, which can cause temporary increases in task execution time and leave less time for the background task to fill the buffer.

Disk read size

Enter the number of bytes to read to fill the buffer.

To understand this parameter, assume the following default values:

- **Buffer size** is 2000
- **Disk read size** is 512
- **Output port width** is 8

This means that the data buffer is of size 2000.

This buffer is initially full. Each time the block executes, eight bytes are output to the model, and the number of bytes in the buffer decreases by eight. Each time the number of free bytes in the buffer goes to 512 or higher, the Simulink Real-Time kernel attempts to read 512 bytes from the Simulink Real-Time data file to fill the buffer.

Setting this parameter to another value, for example 1024, causes the From File block to wait until 1024 bytes are free before attempting the next read.

For efficiency, set this value to a multiple of 512 (a disk sector is 512 bytes).

When reaching EOF

Select the behavior of the block for when you run the real-time application beyond when you have data in the file. Select

- **Hold last output** — Stops reading and stops the output at the last value
- **Seek to beginning** — Returns to the beginning of the file and starts reading the data (this option results in periodic data)

Sample time

Enter the base sample time or a multiple of the base sample time (- 1 means sample time is inherited).

Show IsValid port

Select the **Show IsValid port** check box to make the port IsValid visible in the model. Port IsValid outputs **1** if the file read succeeds and **0** if it fails.

From Target

Read data from target computer

Library

Simulink Real-Time Library for Displays and Logging

Description

This block behaves like a source. Its output is connected to the input of a display device.

You can use the function `SimulinkRealTime.utils.createInstrumentationModel` to create an instrumentation model using the `From Target` and `To Target` blocks.

The `From Target` block runs as a non-real-time Simulink block on the development computer. It is asynchronous to the real-time application running on the target computer. If the real-time application has a sample time slower than the non-real-time model, the `From Target` block can query the target computer more than once. The target computer returns the same value in this case. Conversely, it is possible for the `From Target` block to miss some sample times between two successively returned values.

Note: The use of `From Target` blocks requires a connection between the development and target computers. Without a connection, operations such as opening a model or copying these blocks take longer than normal.

Some notes on the `From Target` block behavior:

- To highlight a signal line that a `From Target` block refers to, double-click the `From Target` block.
- If the `From Target` block has not yet been configured, double-clicking the `From Target` block has no effect.
- To edit the `From Target` block parameters, right-click the block and select **Mask Parameters**.

Block Parameters

Target application name

The function `SimulinkRealTime.utils.createInstrumentationModel` automatically enters a name entry for this parameter. It is the same name as the Simulink model that the Simulink Real-Time software uses to build the real-time application.

Signal name (block name)

The function `SimulinkRealTime.utils.createInstrumentationModel` automatically enters a name entry for this parameter. For multiple blocks, the function creates a `From Target` block for each block. Using this method of specifying signals returns signal values one per time step.

You can also manually enter a cell array of signals for this parameter. Using this method of specifying signals returns the values of a vector of signals (up to 1000) as fast as it can acquire them. The signal values may not be at the same time step and the signal values are more likely to be spaced closely together.

Observer sample time

The function `SimulinkRealTime.utils.createInstrumentationModel` automatically enters the sample time for the Simulink block with this signal. It can be equal to the model base sample time or a multiple of the base sample time.

Use default target PC

Selecting this option directs Simulink Coder to build and download the real-time application to the default target computer. This assumes that you configured a default target computer through the Simulink Real-Time Explorer (see “PCI Bus Ethernet Setup” or “USB-to-Ethernet Setup” if you have not). By default, this check box is selected.

Specify target name

If you deselect the **Use default target PC** check box, this field is displayed. Enter the name of the configured target computer.

See Also

“Creating a Custom Graphical Interface”

Time Stamp Counter

Pentium timestamp counter

Library

Simulink Real-Time Library for Target Information

Description

This block outputs a `uint32` vector of length 2 that contains the timestamp value (`rdtsc`). The output increments up at the CPU clock rate. To convert this rate to time in seconds, divide by clock frequency.

Note: Use this block in models that are on Pentium machines only. Using this block in models that are not on Pentium machines can result in abnormal behavior, including a halt in execution. This block takes an arbitrary input used only to sequence execution of the block.

Time Stamp Delta

Timestamp delta

Library

Simulink Real-Time Library for Target Information

Description

This block takes as input two `uint32` vectors of length 2. Two separate `Time Stamp Counter` blocks can supply each vector. The output is a scalar double that contains the delta between the two timestamps.

Scope

Real-Time Scope block

Library

Simulink Real-Time Library for Displays and Logging

Description

Real-time scope blocks come in three types: **Target**, **Host**, and **File**. The block dialog box changes depending on the setting for parameter **Scope type**. By default, the block dialog box displays the parameters for **Target** scopes. The following sections describe the parameters for each scope type:

- “Target Scope Block Parameters” on page 59-10
- “Host Scope Block Parameters” on page 59-14
- “File Scope Block Parameters” on page 59-16

Note:

- To monitor the output signal from a **Constant** block using a real-time **Scope** block, add a test point for the **Constant** block output signal.
 - If your model connects the output of a **Mux** block to the input of a real-time **Scope** block, the signal is not observable. To observe the signal, add a unity gain block (a **Gain** block with a gain of 1) between the **Mux** block and the **Scope** block.
 - The real-time application can generate data faster than the kernel can process it. Previous data can be overwritten, causing gaps. If gaps occur in the data, consider increasing the value of the **Decimation** property of the scope.
-

Target Scope Block Parameters

Scope number

Contains a unique number to identify the scope that is displayed. This number is incremented each time you add a new Simulink Real-Time Scope block. Typically, you do not need to edit this value.

This number identifies the Simulink Real-Time Scope block and the scope display on the development or target computer.

Scope type

From the list, select **Target** if it is not already selected.

The updated dialog box displays.

Start scope when application starts

Select this check box to start a scope when you download and start the real-time application. The scope window opens automatically.

Scope mode

From the list, select one of the following:

- **Numerical** — Displays the data numerically.
- **Graphical redraw** — Displays a cycle of data continuously without scrolling (refreshing the entire plot).
- **Graphical sliding** — Like graphical rolling mode. This mode displays the older data on the right side of the scope and the newer data on the left side of the scope. A vertical line separates the two types of data.
- **Graphical rolling** — Displays running data continuously scrolling from left to right across the scope (similar behavior to oscilloscopes).

If you have a scope type of **Target** and a scope mode of **Numerical**, the scope block dialog adds a **Numerical format** box to the dialog. You can define the display format for the data. If you choose not to complete the **Numerical format** box, the Simulink Real-Time software displays the signal using the default format of `%15.6f`. This is a floating point format without a label.

Numerical format

If you have a scope type of **Target** and a scope mode of **Numerical**, the scope block dialog adds a **Numerical format** box to the dialog. Enter a label and associated numeric format type in which to display signals. By default, the entry format is the floating point `%15.6f`. The **Numerical format** box takes entries of the format:

```
'[LabelN] [%width.precisiontype] [LabelX]'
```

where

LabelN is the label for the signal. You can use a different label for each signal or the same label for each signal. This argument is optional.

width is the minimum number of characters to offset from the left of the screen or label. This argument is optional.

precision is the maximum number of decimal points for the signal value. This argument is optional.

type is the data type for the signal format. You can use one or more of the following types:

Type	Description
%e or %E	Exponential format using e or E
%f	Floating point
%g	Signed value printed in f or e format depending on which is smaller
%G	Signed value printed in f or E format depending on which is smaller

LabelX is a second label for the signal. You can use a different label for each signal or the same label for each signal. This argument is optional.

Enclose the contents of the **Numerical format** box in quotation marks.

For example

```
'Foo %15.2f end'
```

For a whole integer signal value, enter 0 for the precision value. For example

```
'Foo1 %15.0f end'
```

For a multiple format entries, delimit each entry with a comma and surround the entire string with a pair of quotes. For example

```
'Foo2 %15.6f end,Foo3 %15.6f end2'
```

You can have multiple **Numerical format** entries, separated by a comma. If you enter one entry, that entry applies to the first signal. The default numerical format (%15.6f) applies to the remaining signals. If you enter fewer label entries than

signals, the first entry applies to the first signal, the second entry applies to the second signal, and so forth, and the default format applies to the remaining signals. If you have two entries and one signal, the Simulink Real-Time software ignores the second label entry and applies the first entry. You can enter as many format entries as you have signals for the scope.

Grid

Select this check box to display grid lines on the scope. Note that this parameter is only applicable for target scopes and scope modes of type `Graphical redraw`, `Graphical sliding`, and `Graphical rolling`.

Y-Axis limits

Enter a row vector with two elements where the first element is the lower limit of the y -axis and the second element is the upper limit. If you enter 0 for both elements, then the scaling is set to auto. Note that this parameter is only applicable for target scopes and scope modes of type `Graphical redraw`, `Graphical sliding`, and `Graphical rolling`.

Number of samples

Enter the number of values to be acquired in a data package. The minimum number is 3 samples.

If you select a **Scope mode** of `Graphical redraw`, this parameter specifies the number of values to be acquired before the graph is redrawn.

If you select a **Scope mode** of `Numerical`, the block updates the output every **Number of samples**.

Number of pre/post samples

Enter the number of samples to save or skip. Specify a value less than 0 to save this number of samples before a trigger event. Specify a value greater than 0 to skip this number of samples after the trigger event before data acquisition begins.

Decimation

Enter a value to collect data at each sample time (1) or to collect data at less than every sample time (2 or greater).

Trigger mode

From the list, select one of `FreeRun`, `Software triggering`, `Signal triggering`, or `Scope triggering`.

- `FreeRun` or `Software triggering` — You do not need to enter additional parameters.

- **Signal triggering** — Enter the following additional parameters, as required:
 - In the **Trigger signal** box, enter the index of a signal previously added to the scope.

This parameter does not apply if the **Add signal port to connect a signal trigger source** check box is selected.
 - (Alternatively) Click the **Add signal port to connect a signal trigger source** check box, then connect an arbitrary trigger signal to the port **Trigger signal**.
 - In the **Trigger level** box, enter a value for the signal to cross before triggering.
 - From the **Trigger slope** list, select one of **Either**, **Rising**, or **Falling**.
- **Scope triggering** — Enter the following additional parameters, as required:
 - In the **Trigger scope number** box, enter the scope number of a Scope block. If you use this trigger mode, you must also add a second Scope block to your Simulink model.
 - If you want the scope to trigger on a specific sample of the other scope, enter a value in the text box **Sample to trigger on (-1 for end of acquisition)**. The default value is 0, and indicates that the triggering scope and the triggered (current) scope start simultaneously.

Host Scope Block Parameters

Scope number

Contains a unique number to identify the scope that is displayed. This number is incremented each time you add a new Simulink Real-Time Scope block. Typically, you do not need to edit this value.

This number identifies the Simulink Real-Time Scope block and the scope display on the development or target computer.

Scope type

From the list, select **Host**.

The updated dialog box is displayed.

Start scope when application starts

Select this check box to start a scope when you download and start the real-time application. With a target scope, the scope window opens automatically. With a host scope, you can open a host scope viewer window from Simulink Real-Time Explorer.

Number of samples

Enter the number of values to be acquired in a data package.

Number of pre/post samples

Enter the number of samples to save or skip. Specify a value less than 0 to save this number of samples before a trigger event. Specify a value greater than 0 to skip this number of samples after the trigger event before data acquisition begins.

Decimation

Enter a value to collect data at each sample time (1) or to collect data at less than every sample time (2 or greater).

Trigger mode

From the list, select one of `FreeRun`, `Software triggering`, `Signal triggering`, or `Scope triggering`.

- `FreeRun` or `Software triggering` — You do not need to enter additional parameters.
- `Signal triggering` — Enter the following additional parameters, as required:
 - In the **Trigger signal** box, enter the index of a signal previously added to the scope.

This parameter does not apply if the **Add signal port to connect a signal trigger source** check box is selected.

- (Alternatively) Click the **Add signal port to connect a signal trigger source** check box, then connect an arbitrary trigger signal to the port `Trigger` signal.
- In the **Trigger level** box, enter a value for the signal to cross before triggering.
- From the **Trigger slope** list, select one of `Either`, `Rising`, or `Falling`.
- `Scope triggering` — Enter the following additional parameters, as required:
 - In the **Trigger scope number** box, enter the scope number of a Scope block. If you use this trigger mode, you must also add a second Scope block to your Simulink model.

- If you want the scope to trigger on a specific sample of the other scope, enter a value in the text box **Sample to trigger on (-1 for end of acquisition)**. The default value is 0, and indicates that the triggering scope and the triggered (current) scope start simultaneously.

File Scope Block Parameters

Scope number

Contains a unique number to identify the scope that is displayed. This number is incremented each time you add a new Simulink Real-Time Scope block. Typically, you do not need to edit this value.

This number identifies the Simulink Real-Time Scope block and the scope display on the development or target computer.

Scope type

From the list, select **File**.

The updated dialog box is displayed.

Start scope when application starts

Select the check box to start a scope when you download and start the real-time application. The scope window opens automatically.

Number of samples

Enter the number of values to be acquired in a data package.

The **Number of samples** parameter works with the **AutoRestart** setting.

- Autorestart is on — When the scope triggers, the scope collects data into a memory buffer. A background task examines the buffer and writes data to the disk continuously, appending new data to the end of the file. When the scope reaches the number of samples that you specified, it starts collecting data again, overwriting the memory buffer. If the background task cannot keep up with data collection, data can be lost.
- Autorestart is off — When the scope triggers, the scope collects data into a memory buffer up to the number of samples that you specified, and then the scope stops. A background task examines the buffer and writes data to the disk continuously, appending the new data to the end of the file.

Number of pre/post samples

Enter the number of samples to save or skip. Specify a value less than 0 to save this number of samples before a trigger event. Specify a value greater than 0 to skip this number of samples after the trigger event before data acquisition begins.

Decimation

Enter a value to collect data at each sample time (1) or to collect data at less than every sample time (2 or greater).

Trigger mode

From the list, select one of FreeRun, Software triggering, Signal triggering, or Scope triggering.

- FreeRun or Software triggering — You do not need to enter additional parameters.
- Signal triggering — Enter the following additional parameters, as required:
 - In the **Trigger signal** box, enter the index of a signal previously added to the scope.

This parameter does not apply if the **Add signal port to connect a signal trigger source** check box is selected.
 - (Alternatively) Click the **Add signal port to connect a signal trigger source** check box, then connect an arbitrary trigger signal to the port Trigger signal.
 - In the **Trigger level** box, enter a value for the signal to cross before triggering.
 - From the **Trigger slope** list, select one of **Either**, **Rising**, or **Falling**.
- Scope triggering — Enter the following additional parameters, as required:
 - In the **Trigger scope number** box, enter the scope number of a Scope block. If you use this trigger mode, you must also add a second Scope block to your Simulink model.
 - If you want the scope to trigger on a specific sample of the other scope, enter a value in the text box **Sample to trigger on (-1 for end of acquisition)**. The default value is 0, and indicates that the triggering scope and the triggered (current) scope start simultaneously.

Filename

Enter a name for the file to contain the signal data. By default, the target computer writes the signal data to a file named `C:\data.dat`.

If you select the **Dynamic file name enabled** and **AutoRestart** check boxes, configure **Filename** to dynamically increment. Use a base file name, an underscore (`_`), and a `< >` specifier. Within the specifier, enter one to eight `%` symbols. Each symbol `%` represents a decimal location in the file name. The specifier can appear anywhere in the file name. For example, the following value for **Filename**, `C:\work\file_<%%>.dat` creates file names with the following pattern:

```
file_001.dat
file_002.dat
file_003.dat
```

The last file name of this series will be `file_999.dat`. If the function is still logging data when the last file name reaches its maximum size, the function starts from the beginning and overwrites the first file name in the series.

A fully qualified file name can have a maximum of 260 characters. The file part can have 12 characters — a maximum of eight characters for the file name, one character for the period, and a maximum of three characters for the file extension. If the file name is longer than eight characters, the software truncates it to six characters and adds `~1` to the end of the file name.

Mode

From the list, select either **Lazy** or **Commit**. Both modes open a file, write signal data to the file, then close that file at the end of the session. With the **Commit** mode, each file write operation simultaneously updates the FAT entry for the file. This mode is slower, but the file system maintains the actual file size. With the **Lazy** mode, the FAT entry is updated only when the file is closed and not during each file write operation. This mode is faster, but if the system crashes before the file is closed, the file system might not know the actual file size (the file contents, however, will be intact).

You cannot read a file that was written during real-time execution until execution has completed.

WriteSize

Enter the block size, in bytes, of the data chunks. This parameter specifies that a memory buffer, of length **Number of samples**, writes data to the file in **WriteSize** chunks. By default, this parameter is 512 bytes, which is the typical disk sector size. Using a block size that is the same as the disk sector size provides better performance.

AutoRestart

Select this check box to have the file scope collect data into a memory buffer. A background task examines the buffer and writes data to the disk continuously, appending new data to the end of the file. When the scope has collected the required number of samples, it starts collecting data over again, overwriting the memory buffer. If the background task cannot keep up with data collection, data can be lost.

Clear the **AutoRestart** check box to have the scope collect data into a memory buffer up to the specified number of samples and stop. As when autorestart is on, a background task examines the buffer and writes data to the disk continuously, appending the new data to the end of the file.

Setting this check box enables the following parameters: **Dynamic file name enabled** and **Max file size in bytes (multiple of WriteSize)**.

Dynamic file name enabled

Select this check box to enable the ability to dynamically create multiple log files for file scopes.

To enable this parameter, select the **AutoRestart** check box. When you enable **Dynamic file name enabled**, configure **Filename** to create incrementally numbered file names for the multiple log files. Failure to do so causes an error when you try to start the scope.

You can enable the creation of up to 99999999 files (<%%%%%%%%>.dat). The length of a file name, including the specifier, cannot exceed eight characters.

Max file size in bytes (multiple of WriteSize)

Provide the maximum size of **Filename**, in bytes. This value must be a multiple of **WriteSize**. Default is 536870912.

When the size of a log file reaches **Max file size in bytes (multiple of WriteSize)**, the software creates a subsequently numbered file name, and continues logging data to that file, up until the highest log file number you have specified. If the software cannot create additional log files, it overwrites the first log file.

Software Reboot

Restart target computer software

Library

Simulink Real-Time Library for Target Information

Description

You can use the **Software Reboot** block to restart the target computer when your simulation reaches a certain state. For example, you can restart the target computer when your control system becomes unstable.

This block has one input. The input is the restart signal and accepts the following values:

- 1 — Restarts the target computer.
- 0 — If you use a **Software Reboot** block and you do not want the target computer to restart, the input value to this block must be 0.

Note: Some systems do not support restarting from software. To test whether your system supports a software restart, from the MATLAB Command Window, enter `slrttest`. For more information, see “Run Confidence Test on Configuration”.

Block Parameters

Sample time

Enter the base sample time or a multiple of the base sample time (-1 means sample time is inherited).

To Target

Send data to target computer

Library

Simulink Real-Time Library for Displays and Logging

Description

This block behaves as a sink. The main purpose of this block is to write a new value to a specific parameter on the real-time application.

You can use the function `SimulinkRealTime.utils.createInstrumentationModel` to create an instrumentation model using the `To Target` and `From Target` blocks.

The `To Target` block runs as a non-real-time Simulink block on the development computer. It is asynchronous to the real-time model running on the target computer. If the `To Target` block receives continuously changing input, two parameter updates can be sent to the target computer before the next sample time of the real-time application. In this case, the real-time application only uses the last parameter value received. Conversely, it is also possible for one or more sample times to elapse on the target computer before the `To Target` block sends the next parameter value.

In either case, the `To Target` block only sends parameter values to the target computer when there is a change (for example, the input of the `To Target` block changes).

Note: The use of `To Target` blocks requires a connection between the development and target computers. Without a connection, operations such as opening a model or copying these blocks take longer than normal.

Some notes on the `To Target` block behavior:

- To highlight the Simulink model block referenced by a `To Target` block, double-click the block.

- If the **To Target** block has not yet been configured, double-clicking the block has no effect.
- To edit the **To Target** block parameters, right-click the block and select **Mask Parameters**.

Block Parameters

Target application name

The function `SimulinkRealTime.utils.createInstrumentationModel` automatically enters a name entry for this parameter. It is the same name as the Simulink model that Simulink Real-Time uses to build the real-time application.

Path to block in target application

The function `SimulinkRealTime.utils.createInstrumentationModel` automatically enters an entry for this parameter and uses it to access the block identifier.

Parameter name

The function `SimulinkRealTime.utils.createInstrumentationModel` automatically determines the entry for this parameter and enters it. Note that the parameter name might not match the label name for that parameter in the Block Parameters dialog box. For example, the label name for a gain block is **Constant value**, but the parameter name is **Value**.

Use default target PC

Selecting this option directs Simulink Coder to build and download the real-time application to the default target computer. This assumes that you configured a default target computer through the Simulink Real-Time Explorer (see “PCI Bus Ethernet Setup” or “USB-to-Ethernet Setup” if you have not). By default, this check box is selected.

Specify target name

If you deselect the **Use default target PC** check box, this field is displayed. Enter the name of the configured target computer.

See Also

“Creating a Custom Graphical Interface”

Current Available Stack Size

Current Available Stack Size returns free stack available

Library

Simulink Real-Time Library for Execution Parameters

Description

This block outputs the number of bytes of stack memory currently available to the real-time application thread.

See Also

Minimum Available Stack Size

Minimum Available Stack Size

Get the smallest amount of free stack available

Library

Simulink Real-Time Library for Execution Parameters

Description

This block outputs the number of bytes that have not been used in the stack since the thread was created.

Note: The block traverses the entire stack to find unused bytes. Use this block only for diagnostic purposes.

See Also

Current Available Stack Size

Get Overload Counter

Get Overload Counter returns number of CPU overloads

Library

Simulink Real-Time Library for Execution Parameters

Description

This block returns the CPU overload count. To display the value, connect the block output to a real-time **Scope** block. To achieve your required refresh rate, adjust the Simulink Real-Time **Scope** block parameter **Number of samples** to a small number, such as 10.

For multirate models in multitasking mode, **Get Overload Counter** returns the number of overloads of the base rate task.

Block Parameters

Sample time

Enter the base sample time or a multiple of the base sample time (- 1 means sample time is inherited).

See Also

Set Overload Counter

Set Overload Counter

Set current CPU overload count

Library

Simulink Real-Time Library for Execution Parameters

Description

The block enables you to adjust the CPU overload count.

Block Parameters

Sample time

Enter the base sample time or a multiple of the base sample time (- 1 means sample time is inherited).

See Also

Get Overload Counter

Task Execution Time

Task execution time (TET), in seconds

Library

Simulink Real-Time Library for Execution Parameters

Description

This block outputs the task execution time (TET) in seconds.

To visualize the TET while your real-time application is running, connect the output of this block to a Simulink Real-Time Scope block.

For a single-rate model, task execution time (TET) measures how long it takes the kernel to update the model state, propagate the new model state to the outputs, and log the model state during a sample interval. For a multirate model, TET measures how long it takes the kernel to perform those tasks for the base-rate portion only. You can plot the TET to show under what circumstances subsystems are executed and the additional CPU time required for those executions.

Block Parameters

Sample time

Enter the base sample time or a multiple of the base sample time (- 1 means sample time is inherited).

Session Time

Time kernel has been executing

Library

Simulink Real-Time Library for Target Information

Description

This block outputs the time in clock ticks that the kernel has been executing. This value is not the same as the execution time of the real-time application. It is the time since you last started the target computer.

A use for this block is to determine the execution time of subsystems in your Simulink model. Add a **Session Time** block before and after the subsystem, and then calculate the difference in time.

The time is in clock ticks, and it uses the target computer interval timer to generate the ticks. Since the interval timer runs at a frequency of 1.193 MHz, you can calculate the time in seconds by dividing the output by 1.193×10^6 .

Block Parameters

Sample time

Enter the base sample time or a multiple of the base sample time (-1 means sample time is inherited).

Drivers No Longer Recommended for Use

Simulink Real-Time Drivers No Longer Recommended for Use

The following sets of drivers are no longer recommended for use with the Simulink Real-Time product.

- “Library of Drivers No Longer Recommended for Use” on page 60-2
- “ACCES I/O Drivers No Longer Recommended for Use” on page 60-4
- “Advantech Drivers No Longer Recommended for Use” on page 60-7
- “Analogic Drivers No Longer Recommended for Use” on page 60-83
- “BittWare Drivers No Longer Recommended for Use” on page 60-100
- “Diamond Drivers No Longer Recommended for Use” on page 60-109
- “Displays and Logging Blocks No Longer Recommended for Use” on page 60-138
- “GE Intelligent Platforms Drivers No Longer Recommended for Use” on page 60-143
- “HUMUSOFT Drivers No Longer Recommended for Use” on page 60-159
- “J1939 Drivers No Longer Recommended for Use” on page 60-167
- “Keithley Drivers No Longer Recommended for Use” on page 60-179
- “MathWorks Drivers No Longer Recommended for Use” on page 60-206
- “Measurement Computing Drivers No Longer Recommended for Use” on page 60-211
- “National Instruments Drivers No Longer Recommended for Use” on page 60-430
- “Real Time Devices Drivers No Longer Recommended for Use” on page 60-461
- “Texas Instruments Drivers No Longer Recommended for Use” on page 60-485
- “UDP Blocks No Longer Recommended for Use” on page 60-492
- “Utility Blocks No Longer Recommended for Use” on page 60-497
- “XCP Drivers No Longer Recommended for Use” on page 60-501

Library of Drivers No Longer Recommended for Use

Type `xpcobsoletelib` to access driver blocks that are no longer recommended or that have been updated.

Drivers No Longer Recommended

This library contains blocks and boards for the following drivers that are no longer recommended.

Existing models that use these driver blocks will still work. However, they may not be supported in future releases. Do not use these driver blocks in new models.

- “ACCES I/O Drivers No Longer Recommended for Use” on page 60-4
- “Advantech Drivers No Longer Recommended for Use” on page 60-7
- “Analogic Drivers No Longer Recommended for Use” on page 60-83
- “BittWare Drivers No Longer Recommended for Use” on page 60-100
- “Diamond Drivers No Longer Recommended for Use” on page 60-109
- “Displays and Logging Blocks No Longer Recommended for Use” on page 60-138
- “GE Intelligent Platforms Drivers No Longer Recommended for Use” on page 60-143
- “HUMUSOFT Drivers No Longer Recommended for Use” on page 60-159
- “J1939 Drivers No Longer Recommended for Use” on page 60-167
- “Keithley Drivers No Longer Recommended for Use” on page 60-179
- “MathWorks Drivers No Longer Recommended for Use” on page 60-206
- “Measurement Computing Drivers No Longer Recommended for Use” on page 60-211
- “National Instruments Drivers No Longer Recommended for Use” on page 60-430
- “Real Time Devices Drivers No Longer Recommended for Use” on page 60-461
- “Texas Instruments Drivers No Longer Recommended for Use” on page 60-485
- “UDP Blocks No Longer Recommended for Use” on page 60-492
- “Utility Blocks No Longer Recommended for Use” on page 60-497
- “XCP Drivers No Longer Recommended for Use” on page 60-501

Drivers Updated

The following drivers have been updated.

These versions of these drivers may not be supported in future releases. Use the new version of these drivers.

- Measurement Computing drivers
 - Measurement Computing PCI-QUAD04 Incremental Encoder
- J1939 drivers
 - J1939 Database Setup
 - J1939 Message Triggering
 - J1939 Pack
 - J1939 Receive
 - J1939 Transmit
 - J1939 Unpack

ACCES I/O Drivers No Longer Recommended for Use

ACCES I/O WDG-CSM

Support for ACCES I/O WDG-CSM
watchdog timer (not recommended)

ACCES I/O WDG-CSM Watchdog Timer

WDG-CSM Watchdog Timer block (not
recommended)

ACCES I/O WDG-CSM

Support for ACCES I/O WDG-CSM watchdog timer (not recommended)

Board

Access™ I/O WDG-CSM

General Description

The WDG-CSM is a watchdog timer used to detect computer failure. You can program this watchdog to restart the system when a programmable timeout occurs. The timeout interval can range from 20 microseconds to 400 seconds.

The Simulink Real-Time block library supports this board with one driver block:

- ACCES I/O WDG-CSM Watchdog Timer

Board Characteristics

Board name	WDG-CSM
Manufacturer	ACCES IO
Bus type	ISA
Access method	I/O mapped
Multiple block instance support	No
Multiple board support	Yes

ACCES I/O WDG-CSM Watchdog Timer

WDG-CSM Watchdog Timer block (not recommended)

Library

Simulink Real-Time Library of Drivers No Longer Recommended for Use

Block Parameters

Watchdog Time [s] (20us-4800s)

Enter a timeout value in seconds.

Show reset port

Select this check box to enable an input port on the driver block. A signal connected to this port resets the watchdog.

Sample time

Enter the base sample time or a multiple of the base sample time (- 1 means sample time is inherited).

Base address

Enter the base address of the board. This entry must correspond to the DIP switch setting on the board. For example, if the DIP switch setting is 300 (hexadecimal), enter 0x300.

Advantech Drivers No Longer Recommended for Use

Advantech PCL-1800

Advantech PCL-1800 board (not recommended)

Advantech PCL-1800 Analog Input (A/D)

PCL-1800 Analog Input block (not recommended)

Advantech PCL-1800 Analog Output (D/A)

PCL-1800 Analog Output block (not recommended)

Advantech PCL-1800 Digital Input

PCL-1800 Digital Input block (not recommended)

Advantech PCL-1800 Digital Output

PCL-1800 Digital Output (not recommended)

Advantech PCL-711B

Advantech PCL-711B board (not recommended)

Advantech PCL-711B Analog Input (A/D)

PCL-711B Analog Input block (not recommended)

Advantech PCL-711B Analog Output (D/A)

PCL-711B Analog Output block (not recommended)

Advantech PCL-711B Digital Input

PCL-711B Digital Input (not recommended)

Advantech PCL-711B Digital Output

PCL-711B Digital Output block (not recommended)

Advantech PCL-726

Advantech PCL-726 board (not recommended)

Advantech PCL-726 Analog Output (D/A)

PCL-726 Analog Output block (not recommended)

Advantech PCL-726 Digital Input	PCL-726 Digital Input block (not recommended)
Advantech PCL-726 Digital Output	PCL-726 Digital Input block (not recommended)
Advantech PCL-727	Advantech PCL-727 board (not recommended)
Advantech PCL-727 Analog Output (D/A)	PCL-727 Analog Output block (not recommended)
Advantech PCL-727 Digital Input	PCL-727 Digital Input block (not recommended)
Advantech PCL-727 Digital Output	PCL-727 Digital Input block (not recommended)
Advantech PCL-728	Advantech PCL-728 board (not recommended)
Advantech PCL-728 Analog Output (D/A)	PCL-728 Analog Output block (not recommended)
Advantech PCL-812	Advantech PCL-812 board (not recommended)
Advantech PCL-812 Analog Input (A/D)	PCL-812 Analog Input block (not recommended)
Advantech PCL-812 Analog Output (D/A)	PCL-812 Analog Output block (not recommended)
Advantech PCL-812 Digital Input	PCL-812 Digital Input block (not recommended)

Advantech PCL-812 Digital Output	PCL-812 Digital Output block (not recommended)
Advantech PCL-812PG	Advantech PCL-812PG board (not recommended)
Advantech PCL-812PG Analog Input (A/D)	PCL-812PG Analog Input block (not recommended)
Advantech PCL-812PG Analog Output (D/A)	PCL-812PG Analog Output block (not recommended)
Advantech PCL-812PG Digital Input	PCL-812PG Digital Input block (not recommended)
Advantech PCL-812PG Digital Output	PCL-812PG Digital Input block (not recommended)
Advantech PCL-818	Advantech PCL-818 board (not recommended)
Advantech PCL-818 Analog Input (A/D)	PCL-818 Analog Input (A/D) (not recommended)
Advantech PCL-818 Analog Output (D/A)	PCL-818 Analog Output block (not recommended)
Advantech PCL-818 Digital Input	PCL-818 Digital Input (not recommended)
Advantech PCL-818 Digital Output	PCL-818 Digital Output (not recommended)
Advantech PCL-818H	Advantech PCL-818H board (not recommended)
Advantech PCL-818H Analog Input (A/D)	PCL-818H Analog Input block (not recommended)

Advantech PCL-818H Analog Output (D/A)	PCL-818H Analog Output block (not recommended)
Advantech PCL-818H Digital Input	PCL-818H Digital Input block (not recommended)
Advantech PCL-818H Digital Output	PCL-818H Digital Output block (not recommended)
Advantech PCL-818HD	Advantech PCL-818HD board (not recommended)
Advantech PCL-818HD Analog Input (A/D)	PCL-818HD Analog Input block (not recommended)
Advantech PCL-818HD Analog Output (D/A)	PCL-818HD Analog Output block (not recommended)
Advantech PCL-818HD Digital Input	PCL-818HD Digital Input block (not recommended)
Advantech PCL-818HD Digital Output	PCL-818HD Digital Output block (not recommended)
Advantech PCL-818HG	Advantech PCL-818HG (not recommended)
Advantech PCL-818HG Analog Input (A/D)	PCL-818HG Analog Input block (not recommended)
Advantech PCL-818HG Analog Output (D/A)	PCL-818HG Analog Output block (not recommended)
Advantech PCL-818HG Digital Input	PCL-818HG Digital Input block (not recommended)

Advantech PCL-818HG Digital Output	PCL-818HG Digital Output block (not recommended)
Advantech PCL-818L	Advantech PCL-818L Board (not recommended)
Advantech PCL-818L Analog Input (A/D)	PCL-818L Analog Input block (not recommended)
Advantech PCL-818L Analog Output (D/A)	PCL-818L Analog Output block (not recommended)
Advantech PCL-818L Digital Input	PCL-818L Digital Input block (not recommended)
Advantech PCL-818L Digital Output	PCL-818L Digital Output block (not recommended)

Advantech PCL-1800

Advantech PCL-1800 board (not recommended)

Board

Advantech PCL-1800

General Description

The PCL-1800 is an I/O board with 16 single or eight differential analog channels (12-bit) with a maximum sample rate of 330 kHz, two analog output D/A channels (12-bit), and 16 digital input lines and 16 digital output lines.

The Simulink Real-Time block library supports this board with these driver blocks:

- Advantech PCL-1800 Analog Input (A/D)
- Advantech PCL-1800 Analog Output (D/A)
- Advantech PCL-1800 Digital Input
- Advantech PCL-1800 Digital Output

Board Characteristics

Board Name	PCL-1800
Manufacturer	Advantech
Bus Type	ISA
Access Method	I/O mapped
Multiple block instance support	Yes
Multiple board support	Yes

Advantech PCL-1800 Analog Input (A/D)

PCL-1800 Analog Input block (not recommended)

Library

Simulink Real-Time Library of Drivers No Longer Recommended for Use

Scaling of Input to Output

Hardware Input	Block Output Data Type	Scaling
Volts	Double	1

Block Parameters

Channel vector

If you select 16 channels (**Input coupling** parameter set to **Single-ended**), enter numbers between 1 and 16. If you select differential (**Input coupling** parameter set to **differential**), enter numbers between 1 and 8. For example, to use the first and second analog output (A/D) channels, enter

[1,2]

Number the channels beginning with 1 even if this board manufacturer starts the numbering of the channels with 0.

Range vector

Enter a range code for each of the channels in the channel vector. The range vector must be the same length as the channel vector. This board allows the range of each channel to be different.

The following table is a list of the ranges for this driver and the corresponding range codes.

Input Range (V)	Range Code	Input Range (V)	Range Code
-10 to +10	-10	0 to +10	10

Input Range (V)	Range Code	Input Range (V)	Range Code
-5 to +5	-5	0 to +5	5
-2.5 to +2.5	-2.5	0 to +2.5	2.5
-1.25 to +1.25	-1.25	0 to +1.25	1.25
-0.625 to +0.625	-0.625		

For example, if the first channel is -10 to +10 volts and the second channel is 0 to +5 volts, enter

[-10,5]

The range settings must correspond to the DIP switch settings on the board.

Input coupling

From the list, select one from the following list of input modes:

- Single-ended channels (16 channels)
- differential channels (8 channels)

Your choice must correspond to the MUX switch setting on the board.

Sample time

Enter the base sample time or a multiple of the base sample time (- 1 means sample time is inherited).

Base address

Enter the base address of the board. This entry must correspond to the DIP switch setting on the board. For example, if the DIP switch setting is 300 (hexadecimal), enter 0x300.

Advantech PCL-1800 Analog Output (D/A)

PCL-1800 Analog Output block (not recommended)

Library

Simulink Real-Time Library of Drivers No Longer Recommended for Use

Scaling of Input to Output

Hardware Output	Block Input Data Type	Scaling
Volts	Double	1

Block Parameters

Channel vector

Enter numbers between 1 and 2. This driver allows the selection of individual D/A channels in arbitrary order. The number of elements defines the number of D/A channels you use. For example, to use the first and second analog output (D/A) channels, enter

[1,2]

Number the channels beginning with 1 even if this board manufacturer starts numbering the channels with 0.

Range vector

Enter a range code for each of the channels in the channel vector. The range vector must be the same length as the channel vector. This board allows the range of each channel to be different.

The following table is a list of the ranges for this driver and the corresponding range codes.

Input Range (V)	Range Code	Input Range (V)	Range Code
0 to +10	10	0 to +5	5

For example, if the first channel is 0 to +10 volts and the second channel is 0 to +5 volts, enter

[10,5]

The range settings must correspond to the DIP switch settings on the board.

Sample time

Enter the base sample time or a multiple of the base sample time (- 1 means sample time is inherited).

Base address

Enter the base address of the board. This entry must correspond to the DIP switch setting on the board. For example, if the DIP switch setting is 300 (hexadecimal), enter 0x300.

Advantech PCL-1800 Digital Input

PCL-1800 Digital Input block (not recommended)

Library

Simulink Real-Time Library of Drivers No Longer Recommended for Use

Scaling of Input to Output

Hardware Input	Block Output Data Type	Scaling
TTL	Double	TTL low = 0.0 TTL high = 1.0

Block Parameters

Channel vector

Enter numbers between 1 and 16. This driver allows the selection of individual digital input lines in arbitrary order. The number of elements defines the number of digital lines you use.

For example, to use the first eight digital inputs, enter

```
[1,2,3,4,5,6,7,8]
```

Number the lines beginning with 1 even if this board manufacturer starts numbering the lines with 0.

Sample time

Enter the base sample time or a multiple of the base sample time (-1 means sample time is inherited).

Base address

Enter the base address of the board. This entry must correspond to the DIP switch setting on the board. For example, if the DIP switch setting is 300 (hexadecimal), enter 0x300.

Advantech PCL-1800 Digital Output

PCL-1800 Digital Output (not recommended)

Library

Simulink Real-Time Library of Drivers No Longer Recommended for Use

Scaling of Input to Output

Hardware Output	Block Input Data Type	Scaling
TTL	Double	<0.5 = TTL low ≥0.5 = TTL high

Block Parameters

Channel vector

Enter numbers between 1 and 16. This driver allows the selection of individual digital output lines in arbitrary order. The number of elements defines the number of digital lines you use.

For example, to use the first eight digital outputs, enter

```
[1,2,3,4,5,6,7,8]
```

Number the lines beginning with 1 even if this board manufacturer starts numbering the lines with 0.

Sample time

Enter the base sample time or a multiple of the base sample time (-1 means sample time is inherited).

Base address

Enter the base address of the board. This entry must correspond to the DIP switch setting on the board. For example, if the DIP switch setting is 300 (hexadecimal), enter 0x300.

Advantech PCL-711B

Advantech PCL-711B board (not recommended)

Board

Advantech PCL-711B

General Description

The PCL-711B is an I/O board with eight single-ended analog input channels (12-bit) with a maximum sample rate of 25 kHz, one analog output channel (12-bit), and 16 digital input lines and 16 digital output lines.

The Simulink Real-Time block library supports this board with four driver blocks:

- Advantech PCL-711B Analog Input (A/D)
- Advantech PCL-711B Analog Output (D/A)
- Advantech PCL-711B Digital Input
- Advantech PCL-711B Digital Output

Board Characteristics

Board name	PCL-711B
Manufacturer	Advantech
Bus type	ISA
Access method	I/O mapped
Multiple block instance support	Yes
Multiple board support	Yes

Advantech PCL-711B Analog Input (A/D)

PCL-711B Analog Input block (not recommended)

Library

Simulink Real-Time Library of Drivers No Longer Recommended for Use

Scaling of Input to Output

Hardware Input	Block Output Data Type	Scaling
Volts	Double	1

Block Parameters

Channel vector

Enter numbers between 1 and 8. For example, to use the first and second analog output (A/D) channels, enter

[1, 2]

Number the channels beginning with 1 even if this board manufacturer starts numbering the channels with 0.

Range vector

Enter a range code for each of the channels in the channel vector. The range vector must be the same length as the channel vector. This board allows the range of each channel to be different.

The following table is a list of the ranges for this driver and the corresponding range codes.

Input Range (V)	Range Code
-5 to +5	-5
-2.5 to +2.5	-2.5

Input Range (V)	Range Code
-1.25 to +1.25	-1.25
-0.625 to +0.625	-0.625
-0.3125 to +0.3125	-0.3125

For example, if the first channel is -5 to +5 volts and the second channel is -2.5 to +2.5 volts, enter

[-5, -2.5]

Sample time

Enter the base sample time or a multiple of the base sample time (- 1 means sample time is inherited).

Base address

Enter the base address of the board. This entry must correspond to the DIP switch setting on the board. For example, if the DIP switch setting is 300 (hexadecimal), enter 0x300.

Advantech PCL-711B Analog Output (D/A)

PCL-711B Analog Output block (not recommended)

Library

Simulink Real-Time Library of Drivers No Longer Recommended for Use

Scaling of Input to Output

Hardware Output	Block Input Data Type	Scaling
Volts	Double	1

Block Parameters

Range

From the list, choose either 0 - 10V or 0 - 5V.

The range settings must correspond to the JP1 jumper setting on the board.

Sample time

Enter the base sample time or a multiple of the base sample time (- 1 means sample time is inherited).

Base address

Enter the base address of the board. This entry must correspond to the DIP switch setting on the board. For example, if the DIP switch setting is 300 (hexadecimal), enter 0x300.

Advantech PCL-711B Digital Input

PCL-711B Digital Input (not recommended)

Library

Simulink Real-Time Library of Drivers No Longer Recommended for Use

Scaling of Input to Output

Hardware Input	Block Output Data Type	Scaling
TTL	Double	TTL low = 0.0 TTL high = 1.0

Block Parameters

Channel vector

Enter numbers between 1 and 16. This driver allows the selection of individual digital input lines in arbitrary order. The number of elements defines the number of digital lines used.

For example, to use the first eight digital inputs, enter

```
[1,2,3,4,5,6,7,8]
```

Number the lines beginning with 1 even if this board manufacturer starts numbering the lines with 0.

Sample time

Enter the base sample time or a multiple of the base sample time (-1 means sample time is inherited).

Base address

Enter the base address of the board. This entry must correspond to the DIP switch setting on the board. For example, if the DIP switch setting is 300 (hexadecimal), enter 0x300.

Advantech PCL-711B Digital Output

PCL-711B Digital Output block (not recommended)

Library

Simulink Real-Time Library of Drivers No Longer Recommended for Use

Scaling of Input to Output

Hardware Output	Block Input Data Type	Scaling
TTL	Double	<0.5 = TTL low ≥0.5 = TTL high

Block Parameters

Channel vector

Enter numbers between 1 and 16. This driver allows the selection of individual digital output lines in arbitrary order. The number of elements defines the number of digital lines used.

For example, to use the first eight digital outputs, enter

```
[1,2,3,4,5,6,7,8]
```

Number the lines beginning with 1 even if this board manufacturer starts numbering the lines with 0.

Sample time

Enter the base sample time or a multiple of the base sample time (-1 means sample time is inherited).

Base address

Enter the base address of the board. This entry must correspond to the DIP switch setting on the board. For example, if the DIP switch setting is 300 (hexadecimal), enter 0x300.

Advantech PCL-726

Advantech PCL-726 board (not recommended)

Board

Advantech PCL-726

General Description

The PCL-726 is an I/O board with, six independent analog output D/A channels (12-bit), 16 digital input lines and 16 digital output lines.

The Simulink Real-Time block library supports this board with these driver blocks:

- Advantech PCL-726 Analog Output (D/A)
- Advantech PCL-726 Digital Input
- Advantech PCL-726 Digital Output

Board Characteristics

Board name	PCL-726
Manufacturer	Advantech
Bus type	ISA
Access method	I/O mapped
Multiple block instance support	Yes
Multiple board support	Yes

Advantech PCL-726 Analog Output (D/A)

PCL-726 Analog Output block (not recommended)

Library

Simulink Real-Time Library of Drivers No Longer Recommended for Use

Scaling of Input to Output

Hardware Output	Block Input Data Type	Scaling
Volts	Double	1

Block Parameters

Channel vector

Enter numbers between 1 and 6. This driver allows the selection of individual D/A channels in arbitrary order. The number of elements defines the number of D/A channels you use. For example, to use the first and second analog output (D/A) channels, enter

[1,2]

Number the channels beginning with 1 even if this board manufacturer starts numbering the channels with 0.

Range vector

Enter a range code for each of the channels in the channel vector. The range vector must be the same length as the channel vector. This board allows the range of each channel to be different.

The following table is a list of the ranges for this driver and the corresponding range codes.

Input Range (V)	Range Code
0 to +10	10

Input Range (V)	Range Code
0 to +5	5

For example, if the first channel is 0 to +10 volts and the second channel is 0 to +5 volts, enter

[10,5]

The range settings must correspond to the DIP switch settings on the board.

Sample time

Enter the base sample time or a multiple of the base sample time (- 1 means sample time is inherited).

Base address

Enter the base address of the board. This entry must correspond to the DIP switch setting on the board. For example, if the DIP switch setting is 300 (hexadecimal), enter 0x300.

Advantech PCL-726 Digital Input

PCL-726 Digital Input block (not recommended)

Library

Simulink Real-Time Library of Drivers No Longer Recommended for Use

Scaling of Input to Output

Hardware Input	Block Output Data Type	Scaling
TTL	Double	TTL low = 0.0 TTL high = 1.0

Block Parameters

Channel vector

Enter numbers between 1 and 16. This driver allows the selection of individual digital input lines in arbitrary order. The number of elements defines the number of digital lines you use.

For example, to use the first eight digital inputs, enter

```
[1,2,3,4,5,6,7,8]
```

Number the lines beginning with 1 even if this board manufacturer starts numbering the lines with 0.

Sample time

Enter the base sample time or a multiple of the base sample time (-1 means sample time is inherited).

Base address

Enter the base address of the board. This entry must correspond to the DIP switch setting on the board. For example, if the DIP switch setting is 300 (hexadecimal), enter 0x300.

Advantech PCL-726 Digital Output

PCL-726 Digital Input block (not recommended)

Library

Simulink Real-Time Library of Drivers No Longer Recommended for Use

Scaling of Input to Output

Hardware Output	Block Input Data Type	Scaling
TTL	Double	<0.5 = TTL low ≥0.5 = TTL high

Block Parameters

Channel vector

Enter numbers between 1 and 16. This driver allows the selection of individual digital output lines in arbitrary order. The number of elements defines the number of digital lines you use.

For example, to use the first eight digital outputs, enter

```
[1,2,3,4,5,6,7,8]
```

Number the lines beginning with 1 even if this board manufacturer starts numbering the lines with 0.

Sample time

Enter the base sample time or a multiple of the base sample time (-1 means sample time is inherited).

Base address

Enter the base address of the board. This entry must correspond to the DIP switch setting on the board. For example, if the DIP switch setting is 300 (hexadecimal), enter 0x300.

Advantech PCL-727

Advantech PCL-727 board (not recommended)

Board

Advantech PCL-727

General Description

The PCL-727 is an I/O board with 12 independent analog output D/A channels (12-bit), 16 digital input lines and 16 digital output lines.

The Simulink Real-Time block library supports this board with these driver blocks:

- Advantech PCL-727 Analog Output (D/A)
- Advantech PCL-727 Digital Input
- Advantech PCL-727 Digital Output

Board Characteristics

Board name	PCL-727
Manufacturer	Advantech
Bus type	ISA
Access method	I/O mapped
Multiple block instance support	Yes
Multiple board support	Yes

Advantech PCL-727 Analog Output (D/A)

PCL-727 Analog Output block (not recommended)

Library

Simulink Real-Time Library of Drivers No Longer Recommended for Use

Scaling of Input to Output

Hardware Output	Block Input Data Type	Scaling
Volts	Double	1

Block Parameters

Channel vector

Enter numbers between 1 and 12. This driver allows the selection of individual D/A channels in arbitrary order. The number of elements defines the number of D/A channels you use. For example, to use the first and second analog output (D/A) channels, enter

[1,2]

Number the channels beginning with 1 even if this board manufacturer starts numbering the channels with 0.

Range vector

Enter a range code for each of the channels in the channel vector. The range vector must be the same length as the channel vector. This board allows the range of each channel to be different.

The following table is a list of the ranges for this driver and the corresponding range codes.

Input Range (V)	Range Code
-5 to +5	-5

Input Range (V)	Range Code
0 to +5	5
0 to +10	10

For example, if the first channel is 0 to +10 volts and the second channel is 0 to +5 volts, enter

[10, 5]

The range settings must correspond to the DIP switch settings on the board.

Sample time

Enter the base sample time or a multiple of the base sample time (- 1 means sample time is inherited).

Base address

Enter the base address of the board. This entry must correspond to the DIP switch setting on the board. For example, if the DIP switch setting is 300 (hexadecimal), enter 0x300.

Advantech PCL-727 Digital Input

PCL-727 Digital Input block (not recommended)

Library

Simulink Real-Time Library of Drivers No Longer Recommended for Use

Scaling of Input to Output

Hardware Input	Block Output Data Type	Scaling
TTL	Double	TTL low = 0.0 TTL high = 1.0

Block Parameters

Channel vector

Enter numbers between 1 and 16. This driver allows the selection of individual digital input lines in arbitrary order. The number of elements defines the number of digital lines you use.

For example, to use the first eight digital inputs, enter

```
[1,2,3,4,5,6,7,8]
```

Number the lines beginning with 1 even if this board manufacturer starts numbering the lines with 0.

Sample time

Enter the base sample time or a multiple of the base sample time (-1 means sample time is inherited).

Base address

Enter the base address of the board. This entry must correspond to the DIP switch setting on the board. For example, if the DIP switch setting is 300 (hexadecimal), enter 0x300.

Advantech PCL-727 Digital Output

PCL-727 Digital Input block (not recommended)

Library

Simulink Real-Time Library of Drivers No Longer Recommended for Use

Scaling of Input to Output

Hardware Output	Block Input Data Type	Scaling
TTL	Double	<0.5 = TTL low ≥0.5 = TTL high

Block Parameters

Channel vector

Enter numbers between 1 and 16. This driver allows the selection of individual digital output lines in arbitrary order. The number of elements defines the number of digital lines you use.

For example, to use the first eight digital outputs, enter

```
[1,2,3,4,5,6,7,8]
```

Number the lines beginning with 1 even if this board manufacturer starts numbering the lines with 0.

Sample time

Enter the base sample time or a multiple of the base sample time (-1 means sample time is inherited).

Base address

Enter the base address of the board. This entry must correspond to the DIP switch setting on the board. For example, if the DIP switch setting is 300 (hexadecimal), enter 0x300.

Advantech PCL-728

Advantech PCL-728 board (not recommended)

Board

Advantech PCL-728

General Description

The PCL-728 is an I/O board with two independent analog output D/A channels (12-bit).

The Simulink Real-Time block library supports this board with this driver block:

- Advantech PCL-728 Analog Output (D/A)

Board Characteristics

Board name	PCL-728
Manufacturer	Advantech
Bus Type	ISA
Access method	I/O mapped
Multiple block instance support	Yes
Multiple board support	Yes

Advantech PCL-728 Analog Output (D/A)

PCL-728 Analog Output block (not recommended)

Library

Simulink Real-Time Library of Drivers No Longer Recommended for Use

Scaling of Input to Output

Hardware Output	Block Input Data Type	Scaling
Volts	Double	1

Block Parameters

Channel vector

Enter numbers between 1 and 2. This driver allows the selection of individual D/A channels in arbitrary order. The number of elements defines the number of D/A channels you use. For example, to use the first and second analog output (D/A) channels, enter

[1,2]

Channel numbers begin with 1 even if this board manufacturer starts numbering channels with 0.

Range vector

Enter a range code for each of the channels in the channel vector. The range vector must be the same length as the channel vector. This board allows the range of each channel to be different.

The following table is a list of the ranges for this driver and the corresponding range codes.

Input Range (V)	Range Code
-10 to +10	-10

Input Range (V)	Range Code
-5 to +5	-5
0 to +10	10
0 to +5	5

For example, if the first channel is -10 to +10 volts and the second channel is 0 to +5 volts, enter

[-10,5]

The range settings must correspond to the DIP switch settings on the board.

Sample time

Enter the base sample time or a multiple of the base sample time (- 1 means sample time is inherited).

Base address

Enter the base address of the board. This entry must correspond to the DIP switch setting on the board. For example, if the DIP switch setting is 300 (hexadecimal), enter 0x300.

Advantech PCL-812

Advantech PCL-812 board (not recommended)

Board

Advantech PCL-812

General Description

The PCL-812 is an I/O board with 16 single-ended analog input channels (12-bit) with a maximum sample rate of 30 kHz, two analog output D/A channels (12-bit), and 16 digital input lines and 16 digital output lines.

The Simulink Real-Time block library supports this board with these driver blocks:

- Advantech PCL-812 Analog Input (A/D)
- Advantech PCL-812 Analog Output (D/A)
- Advantech PCL-812 Digital Input
- Advantech PCL-812 Digital Output

Board Characteristics

Board name	PCL-812
Manufacturer	Advantech
Bus type	ISA
Access method	I/O mapped
Multiple block instance support	Yes
Multiple board support	Yes

Advantech PCL-812 Analog Input (A/D)

PCL-812 Analog Input block (not recommended)

Library

Simulink Real-Time Library of Drivers No Longer Recommended for Use

Scaling of Input to Output

Hardware Input	Block Output Data Type	Scaling
Volts	Double	1

Block Parameters

Channel vector

Enter numbers between 1 and 16. For example, to use the first and second analog input (A/D) channels, enter

[1, 2]

Number the channels beginning with 1 even if this board manufacturer starts numbering the channels with 0.

Range vector

Enter a range code for each of the channels in the channel vector. The range vector must be the same length as the channel vector. This board allows the range of each channel to be different.

The following table is a list of the ranges for this driver and the corresponding range codes.

Input Range (V)	Range Code
-10 to +10	-10
-5 to +5	-5

Input Range (V)	Range Code
-2.0 to +2.0	-2.0
-1.0 to +1.0	-1.25

For example, if the first channel is -10 to +10 volts and the second channel is -5 to +5 volts, enter

[-10, -5]

The range settings must correspond to the DIP switch settings on the board.

Sample time

Enter the base sample time or a multiple of the base sample time (- 1 means sample time is inherited).

Base address

Enter the base address of the board. This entry must correspond to the DIP switch setting on the board. For example, if the DIP switch setting is 300 (hexadecimal), enter 0x300.

Advantech PCL-812 Analog Output (D/A)

PCL-812 Analog Output block (not recommended)

Scaling of Input to Output

Hardware Output	Block Input Data Type	Scaling
Volts	Double	1

Block Parameters

Channel vector

Enter numbers between 1 and 2. This driver allows the selection of individual D/A channels in arbitrary order. The number of elements defines the number of D/A channels you use. For example, to use the first and second analog output (D/A) channels, enter

[1,2]

Number the channels beginning with 1 even if this board manufacturer starts numbering the channels with 0.

Range vector

Enter a range code for each of the channels in the channel vector. The range vector must be the same length as the channel vector. This board allows the range of each channel to be different.

The following table is a list of the ranges for this driver and the corresponding range codes.

Input Range (V)	Range code
0 to +5	5

For example, if both channels are 0 to +5 volts, enter

[5,5]

The range settings must correspond to the DIP switch settings on the board.

Sample time

Enter the base sample time or a multiple of the base sample time (- 1 means sample time is inherited).

Base address

Enter the base address of the board. This entry must correspond to the DIP switch setting on the board. For example, if the DIP switch setting is 300 (hexadecimal), enter 0x300.

Advantech PCL-812 Digital Input

PCL-812 Digital Input block (not recommended)

Library

Simulink Real-Time Library of Drivers No Longer Recommended for Use

Scaling of Input to Output

Hardware Input	Block Output Data Type	Scaling
TTL	Double	TTL low = 0.0 TTL high = 1.0

Block Parameters

Channel vector

Enter numbers between 1 and 16. This driver allows the selection of individual digital input lines in arbitrary order. The number of elements defines the number of digital lines used.

For example, to use the first eight digital inputs, enter

```
[1,2,3,4,5,6,7,8]
```

Number the lines beginning with 1 even if this board manufacturer starts numbering the lines with 0.

Sample time

Enter the base sample time or a multiple of the base sample time (-1 means sample time is inherited).

Base address

Enter the base address of the board. This entry must correspond to the DIP switch setting on the board. For example, if the DIP switch setting is 300 (hexadecimal), enter 0x300.

Advantech PCL-812 Digital Output

PCL-812 Digital Output block (not recommended)

Library

Simulink Real-Time Library of Drivers No Longer Recommended for Use

Scaling of Input to Output

Hardware Output	Block Input Data Type	Scaling
TTL	Double	<0.5 = TTL low ≥0.5 = TTL high

Block Parameters

Channel vector

Enter numbers between 1 and 16. This driver allows the selection of individual digital output lines in arbitrary order. The number of elements defines the number of digital lines used.

For example, to use the first eight digital outputs, enter

```
[1,2,3,4,5,6,7,8]
```

Number the lines beginning with 1 even if this board manufacturer starts numbering the lines with 0.

Sample time

Enter the base sample time or a multiple of the base sample time (-1 means sample time is inherited).

Base address

Enter the base address of the board. This entry must correspond to the DIP switch setting on the board. For example, if the DIP switch setting is 300 (hexadecimal), enter 0x300.

Advantech PCL-812PG

Advantech PCL-812PG board (not recommended)

Board

Advantech PCL-812PG

General Description

The PCL-812PG is an I/O board with 16 single or eight differential analog channels (12-bit) with a maximum sample rate of 30 kHz, two analog output D/A channels (12-bit), and 16 digital input lines and 16 digital output lines.

The Simulink Real-Time block library supports this board with these driver blocks:

- Advantech PCL-812PG Analog Input (A/D)
- Advantech PCL-812PG Analog Output (D/A)
- Advantech PCL-812PG Digital Input
- Advantech PCL-812PG Digital Output

Board Characteristics

Board name	PCL-812PG
Manufacturer	Advantech
Bus type	ISA
Access method	I/O mapped
Multiple block instance support	Yes
Multiple board support	Yes

Advantech PCL-812PG Analog Input (A/D)

PCL-812PG Analog Input block (not recommended)

Library

Simulink Real-Time Library of Drivers No Longer Recommended for Use

Scaling of Input to Output

Hardware Input	Block Output Data Type	Scaling
Volts	Double	1

Block Parameters

Channel vector

Enter numbers between 1 and 16. For example, to use the first and second analog input (A/D) channels, enter

[1,2]

Number the channels beginning with 1 even if this board manufacturer starts numbering the channels with 0.

Range vector

Enter a range code for each of the channels in the channel vector. The range vector must be the same length as the channel vector. This board allows the range of each channel to be different.

The following table is a list of the ranges for this driver and the corresponding range codes.

Input Range (V)	Range Code
-10 to +10	-10

Input Range (V)	Range Code
-5 to +5	-5
-2.5 to +2.5	-2.5
-1.25 to +1.25	-1.25
-0.625 to +0.625	-0.625
0 to +10	10
0 to +5	5
0 to +2.5	2.5
0 to +1.25	1.25

For example, if the first channel is -10 to +10 volts and the second channel is 0 to +5 volts, enter

[-10,5]

The range settings must correspond to the DIP switch settings on the board.

Sample time

Enter the base sample time or a multiple of the base sample time (-1 means sample time is inherited).

Base address

Enter the base address of the board. This entry must correspond to the DIP switch setting on the board. For example, if the DIP switch setting is 300 (hexadecimal), enter 0x300.

Advantech PCL-812PG Analog Output (D/A)

PCL-812PG Analog Output block (not recommended)

Library

Simulink Real-Time Library of Drivers No Longer Recommended for Use

Scaling of Input to Output

Hardware Output	Block Input Data Type	Scaling
Volts	Double	1

Block Parameters

Channel vector

Enter numbers between 1 and 2. This driver allows the selection of individual D/A channels in arbitrary order. The number of elements defines the number of D/A channels you use. For example, to use the first and second analog output (D/A) channels, enter

[1,2]

Number the channels beginning with 1 even if this board manufacturer starts numbering the channels with 0.

Range vector

Enter a range code for each of the channels in the channel vector. The range vector must be the same length as the channel vector. This board allows the range of each channel to be different.

The following table is a list of the ranges for this driver and the corresponding range codes.

Input Range (V)	Range Code
-10 to +10	-10

Input Range (V)	Range Code
-5 to +5	-5
0 to +10	10
0 to +5	5

For example, if the first channel is -10 to +10 volts and the second channel is 0 to +5 volts, enter

[-10,5]

The range settings must correspond to the DIP switch settings on the board.

Sample time

Enter the base sample time or a multiple of the base sample time (- 1 means sample time is inherited).

Base address

Enter the base address of the board. This entry must correspond to the DIP switch setting on the board. For example, if the DIP switch setting is 300 (hexadecimal), enter 0x300.

Advantech PCL-812PG Digital Input

PCL-812PG Digital Input block (not recommended)

Library

Simulink Real-Time Library of Drivers No Longer Recommended for Use

Scaling of Input to Output

Hardware Input	Block Output Data Type	Scaling
TTL	Double	TTL low = 0.0 TTL high = 1.0

Block Parameters

Channel vector

Enter numbers between 1 and 16. This driver allows the selection of individual digital input lines in arbitrary order. The number of elements defines the number of digital lines used.

For example, to use the first eight digital inputs, enter

```
[1,2,3,4,5,6,7,8]
```

Number the lines beginning with 1 even if this board manufacturer starts numbering the lines with 0.

Sample time

Enter the base sample time or a multiple of the base sample time (-1 means sample time is inherited).

Base address

Enter the base address of the board. This entry must correspond to the DIP switch setting on the board. For example, if the DIP switch setting is 300 (hexadecimal), enter 0x300.

Advantech PCL-812PG Digital Output

PCL-812PG Digital Input block (not recommended)

Library

Simulink Real-Time Library of Drivers No Longer Recommended for Use

Scaling of Input to Output

Hardware Output	Block Input Data Type	Scaling
TTL	Double	<0.5 = TTL low ≥0.5 = TTL high

Block Parameters

Channel vector

Enter numbers between 1 and 16. This driver allows the selection of individual digital output lines in arbitrary order. The number of elements defines the number of digital lines used.

For example, to use the first eight digital outputs, enter

```
[1,2,3,4,5,6,7,8]
```

Number the lines beginning with 1 even if this board manufacturer starts numbering the lines with 0.

Sample time

Enter the base sample time or a multiple of the base sample time (-1 means sample time is inherited).

Base address

Enter the base address of the board. This entry must correspond to the DIP switch setting on the board. For example, if the DIP switch setting is 300 (hexadecimal), enter 0x300.

Advantech PCL-818

Advantech PCL-818 board (not recommended)

Board

Advantech PCL-818

General Description

The PCL-818 is an I/O board with 16 single or eight differential analog channels (12-bit) with a maximum sample rate of 100 kHz, two analog output D/A channels (12-bit), and 16 digital input lines and 16 digital output lines.

The Simulink Real-Time block library supports this board with these driver blocks:

- Advantech PCL-818 Analog Input (A/D)
- Advantech PCL-818 Analog Output (D/A)
- Advantech PCL-818 Digital Input
- Advantech PCL-818 Digital Output

Board Characteristics

Board name	PCL-818
Manufacturer	Advantech
Bus type	ISA
Access method	I/O mapped
Multiple block instance support	Yes
Multiple board support	Yes

Advantech PCL-818 Analog Input (A/D)

PCL-818 Analog Input (A/D) (not recommended)

Library

Simulink Real-Time Library of Drivers No Longer Recommended for Use

Scaling of Input to Output

Hardware Input	Block Output Data Type	Scaling
Volts	Double	1

Block Parameters

Channel vector

If you select 16 channels (**Input coupling** parameter set to **Single-ended**), enter numbers between 1 and 16. If you select differential (**Input coupling** parameter set to **differential**), enter numbers between 1 and 8. For example, to use the first and second analog output (A/D) channels, enter

[1,2]

Number the channels beginning with 1 even if this board manufacturer starts to number the channels with 0.

Range vector

Enter a range code for each of the channels in the channel vector. The range vector must be the same length as the channel vector. This board allows the range of each channel to be different.

The following table is a list of the ranges for this driver and the corresponding range codes.

Input Range (V)	Range Code
-10 to +10	-10

Input Range (V)	Range Code
-5 to +5	-5
-2.5 to +2.5	-2.5
-1.25 to +1.25	-1.25
-0.625 to +0.625	-0.625
0 to 10	10
0 to +5	5
0 to +2.5	2.5
0 to +1.25	1.25

For example, if the first channel is -10 to +10 volts and the second channel is 0 to +5 volts, enter

`[-10,5]`

The range settings must correspond to the DIP switch settings on the board.

Input coupling

From the list, select one from the following list of input modes:

- Single-ended channels (16 channels)
- differential channels (8 channels)

Your choice must correspond to the MUX switch setting on the board.

Sample time

Enter the base sample time or a multiple of the base sample time (-1 means sample time is inherited).

Base address

Enter the base address of the board. This entry must correspond to the DIP switch setting on the board. For example, if the DIP switch setting is 300 (hexadecimal), enter `0x300`.

Advantech PCL-818 Analog Output (D/A)

PCL-818 Analog Output block (not recommended)

Library

Simulink Real-Time Library of Drivers No Longer Recommended for Use

Scaling of Input to Output

Hardware Output	Block Input Data Type	Scaling
Volts	Double	1

Block Parameters

Channel vector

Enter numbers between 1 and 2. This driver allows the selection of individual D/A channels in arbitrary order. The number of elements defines the number of D/A channels you use. For example, to use the first and second analog output (D/A) channels, enter

[1,2]

Number the channels beginning with 1 even if this board manufacturer starts numbering the channels with 0.

Range vector

Enter a range code for each of the channels in the channel vector. The range vector must be the same length as the channel vector. This board allows the range of each channel to be different.

The following table is a list of the ranges for this driver and the corresponding range codes.

Input Range (V)	Range Code
-10 to +10	-10

Input Range (V)	Range Code
-5 to +5	-5
0 to +10	10
0 to +5	5

For example, if the first channel is -10 to +10 volts and the second channel is 0 to +5 volts, enter

[-10,5]

The range settings must correspond to the DIP switch settings on the board.

Sample time

Enter the base sample time or a multiple of the base sample time (- 1 means sample time is inherited).

Base address

Enter the base address of the board. This entry must correspond to the DIP switch setting on the board. For example, if the DIP switch setting is 300 (hexadecimal), enter 0x300.

Advantech PCL-818 Digital Input

PCL-818 Digital Input (not recommended)

Library

Simulink Real-Time Library of Drivers No Longer Recommended for Use

Scaling of Input to Output

Hardware Input	Block Output Data Type	Scaling
TTL	Double	TTL low = 0.0 TTL high = 1.0

Block Parameters

Channel vector

Enter numbers between 1 and 16. This driver allows the selection of individual digital input lines in arbitrary order. The number of elements defines the number of digital lines used.

For example, to use the first eight digital inputs, enter

```
[1,2,3,4,5,6,7,8]
```

Number the lines beginning with 1 even if this board manufacturer starts numbering the lines with 0.

Sample time

Enter the base sample time or a multiple of the base sample time (-1 means sample time is inherited).

Base address

Enter the base address of the board. This entry must correspond to the DIP switch setting on the board. For example, if the DIP switch setting is 300 (hexadecimal), enter 0x300.

Advantech PCL-818 Digital Output

PCL-818 Digital Output (not recommended)

Library

Simulink Real-Time Library of Drivers No Longer Recommended for Use

Scaling of Input to Output

Hardware Output	Block Input Data Type	Scaling
TTL	Double	<0.5 = TTL low ≥0.5 = TTL high

Block Parameters

Channel vector

Enter numbers between 1 and 16. This driver allows the selection of individual digital output lines in arbitrary order. The number of elements defines the number of digital lines used.

For example, to use the first eight digital outputs, enter

```
[1,2,3,4,5,6,7,8]
```

Number the lines beginning with 1 even if this board manufacturer starts numbering the lines with 0.

Sample time

Enter the base sample time or a multiple of the base sample time (-1 means sample time is inherited).

Base address

Enter the base address of the board. This entry must correspond to the DIP switch setting on the board. For example, if the DIP switch setting is 300 (hexadecimal), enter 0x300.

Advantech PCL-818H

Advantech PCL-818H board (not recommended)

Board

Advantech PCL-818H

General Description

The PCL-818H is an I/O board with 16 single or eight differential analog channels (12-bit) with a maximum sample rate of 100 kHz, one analog output D/A channel (12-bit), and 16 digital input lines and 16 digital output lines.

The Simulink Real-Time block library supports this board with these driver blocks:

Board Characteristics

Board name	PCL-818H
Manufacturer	Advantech
Bus type	ISA
Access method	I/O mapped
Multiple block instance support	Yes
Multiple board support	Yes

Advantech PCL-818H Analog Input (A/D)

PCL-818H Analog Input block (not recommended)

Library

Simulink Real-Time Library of Drivers No Longer Recommended for Use

Scaling of Input to Output

Hardware Input	Block Output Data Type	Scaling
Volts	Double	1

Block Parameters

Channel vector

If you select 16 channels (**Input coupling** parameter set to **Single-ended**), enter numbers between 1 and 16. If you select **differential** (**Input coupling** parameter set to **differential**), enter numbers between 1 and 8. For example, to use the first and second analog output (A/D) channels, enter

[1,2]

Number the channels beginning with 1 even if this board manufacturer starts to number the channels with 0.

Range vector

Enter a range code for each of the channels in the channel vector. The range vector must be the same length as the channel vector. This board allows the range of each channel to be different.

The following table is a list of the ranges for this driver and the corresponding range codes.

Input Range (V)	Range Code
-10 to +10	-10

Input Range (V)	Range Code
-5 to +5	-5
-2.5 to +2.5	-2.5
-1.25 to +1.25	-1.25
-0.625 to +0.625	-0.625
0 to 10	10
0 to +5	5
0 to +2.5	2.5
0 to +1.25	1.25

For example, if the first channel is -10 to +10 volts and the second channel is 0 to +5 volts, enter

[-10,5]

The range settings must correspond to the DIP switch settings on the board.

Input coupling

From the list, select one from the following list of input modes:

- Single-ended channels (16 channels)
- differential channels (8 channels)

This choice must correspond to the MUX switch setting on the board.

Sample time

Enter the base sample time or a multiple of the base sample time (- 1 means sample time is inherited).

Base address

Enter the base address of the board. This entry must correspond to the DIP switch setting on the board. For example, if the DIP switch setting is 300 (hexadecimal), enter 0x300.

Advantech PCL-818H Analog Output (D/A)

PCL-818H Analog Output block (not recommended)

Library

Simulink Real-Time Library of Drivers No Longer Recommended for Use

Scaling of Input to Output

Hardware Output	Block Input Data Type	Scaling
Volts	Double	1

Block Parameters

Range

From the list, choose either 0 - 10V or 0 - 5V.

The range settings must correspond to the DIP switch settings on the board.

Sample time

Enter the base sample time or a multiple of the base sample time (- 1 means sample time is inherited).

Base address

Enter the base address of the board. This entry must correspond to the DIP switch setting on the board. For example, if the DIP switch setting is 300 (hexadecimal), enter 0x300.

Advantech PCL-818H Digital Input

PCL-818H Digital Input block (not recommended)

Library

Simulink Real-Time Library of Drivers No Longer Recommended for Use

Scaling of Input to Output

Hardware Input	Block Output Data Type	Scaling
TTL	Double	TTL low = 0.0 TTL high = 1.0

Block Parameters

Channel vector

Enter numbers between 1 and 16. This driver allows the selection of individual digital input lines in arbitrary order. The number of elements defines the number of digital lines you use.

For example, to use the first eight digital inputs, enter

```
[1,2,3,4,5,6,7,8]
```

Number the lines beginning with 1 even if this board manufacturer starts numbering the lines with 0.

Sample time

Enter the base sample time or a multiple of the base sample time (-1 means sample time is inherited).

Base address

Enter the base address of the board. This entry must correspond to the DIP switch setting on the board. For example, if the DIP switch setting is 300 (hexadecimal), enter 0x300.

Advantech PCL-818H Digital Output

PCL-818H Digital Output block (not recommended)

Library

Simulink Real-Time Library of Drivers No Longer Recommended for Use

Scaling of Input to Output

Hardware Output	Block Input Data Type	Scaling
TTL	Double	<0.5 = TTL low ≥0.5 = TTL high

Block Parameters

Channel vector

Enter numbers between 1 and 16. This driver allows the selection of individual digital output lines in arbitrary order. The number of elements defines the number of digital lines you use.

For example, to use the first eight digital outputs, enter

```
[1,2,3,4,5,6,7,8]
```

Number the lines beginning with 1 even if this board manufacturer starts numbering the lines with 0.

Sample time

Enter the base sample time or a multiple of the base sample time (-1 means sample time is inherited).

Base address

Enter the base address of the board. This entry must correspond to the DIP switch setting on the board. For example, if the DIP switch setting is 300 (hexadecimal), enter 0x300.

Advantech PCL-818HD

Advantech PCL-818HD board (not recommended)

Board

Advantech PCL-818HD

General Description

The PCL-818HD is an I/O board with 16 single or eight differential analog channels (12-bit) with a maximum sample rate of 100 kHz, one analog output D/A channels (12-bit), and 16 digital input lines and 16 digital output lines.

The Simulink Real-Time block library supports this board with these driver blocks:

- Advantech PCL-818HD Analog Input (A/D)
- Advantech PCL-818HD Analog Output (D/A)
- Advantech PCL-818HD Digital Input
- Advantech PCL-818HD Digital Output

Board Characteristics

Board name	PCL-818HD
Manufacturer	Advantech
Bus type	ISA
Access method	I/O mapped
Multiple block instance support	Yes
Multiple board support	Yes

Advantech PCL-818HD Analog Input (A/D)

PCL-818HD Analog Input block (not recommended)

Library

Simulink Real-Time Library of Drivers No Longer Recommended for Use

Scaling of Input to Output

Hardware Input	Block Output Data Type	Scaling
Volts	Double	1

Block Parameters

Channel vector

If you select 16 channels (**Input coupling** parameter set to **Single-ended**), enter numbers between 1 and 16. If you select differential (**Input coupling** parameter set to **differential**), enter numbers between 1 and 8. For example, to use the first and second analog output (A/D) channels, enter

[1,2]

Number the channels beginning with 1 even if this board manufacturer starts to number the channels with 0.

Range vector

Enter a range code for each of the channels in the channel vector. The range vector must be the same length as the channel vector. This board allows the range of each channel to be different.

The following table is a list of the ranges for this driver and the corresponding range codes.

Input Range (V)	Range Code
-10 to +10	-10

Input Range (V)	Range Code
-5 to +5	-5
-2.5 to +2.5	-2.5
-1.25 to +1.25	-1.25
-0.625 to +0.625	-0.625
0 to 10	10
0 to +5	5
0 to +2.5	2.5
0 to +1.25	1.25

For example, if the first channel is -10 to +10 volts and the second channel is 0 to +5 volts, enter

[-10,5]

The range settings must correspond to the DIP switch settings on the board.

Input coupling

From the list, select one from the following list of input modes:

- Single-ended channels (16 channels)
- differential channels (8 channels)

Your choice must correspond to the MUX switch setting on the board.

Sample time

Enter the base sample time or a multiple of the base sample time (- 1 means sample time is inherited).

Base address

Enter the base address of the board. This entry must correspond to the DIP switch setting on the board. For example, if the DIP switch setting is 300 (hexadecimal), enter 0x300.

Advantech PCL-818HD Analog Output (D/A)

PCL-818HD Analog Output block (not recommended)

Library

Simulink Real-Time Library of Drivers No Longer Recommended for Use

Scaling of Input to Output

Hardware Output	Block Input Data Type	Scaling
Volts	Double	1

Block Parameters

Range

From the list, choose either 0 - 10V or 0 - 5V.

The range settings must correspond to the DIP switch settings on the board.

Sample time

Enter the base sample time or a multiple of the base sample time (- 1 means sample time is inherited).

Base address

Enter the base address of the board. This entry must correspond to the DIP switch setting on the board. For example, if the DIP switch setting is 300 (hexadecimal), enter 0x300.

Advantech PCL-818HD Digital Input

PCL-818HD Digital Input block (not recommended)

Library

Simulink Real-Time Library of Drivers No Longer Recommended for Use

Scaling of Input to Output

Hardware Input	Block Output Data Type	Scaling
TTL	Double	TTL low = 0.0 TTL high = 1.0

Block Parameters

Channel vector

Enter numbers between 1 and 16. This driver allows the selection of individual digital input lines in arbitrary order. The number of elements defines the number of digital lines you use.

For example, to use the first eight digital inputs, enter

```
[1,2,3,4,5,6,7,8]
```

Number the lines beginning with 1 even if this board manufacturer starts numbering the lines with 0.

Sample time

Enter the base sample time or a multiple of the base sample time (-1 means sample time is inherited).

Base address

Enter the base address of the board. This entry must correspond to the DIP switch setting on the board. For example, if the DIP switch setting is 300 (hexadecimal), enter 0x300.

Advantech PCL-818HD Digital Output

PCL-818HD Digital Output block (not recommended)

Library

Simulink Real-Time Library of Drivers No Longer Recommended for Use

Scaling of Input to Output

Hardware Output	Block Input Data Type	Scaling
TTL	Double	<0.5 = TTL low ≥0.5 = TTL high

Block Parameters

Channel vector

Enter numbers between 1 and 16. This driver allows the selection of individual digital output lines in arbitrary order. The number of elements defines the number of digital lines you use.

For example, to use the first eight digital outputs, enter

```
[1,2,3,4,5,6,7,8]
```

Number the lines beginning with 1 even if this board manufacturer starts numbering the lines with 0.

Sample time

Enter the base sample time or a multiple of the base sample time (-1 means sample time is inherited).

Base address

Enter the base address of the board. This entry must correspond to the DIP switch setting on the board. For example, if the DIP switch setting is 300 (hexadecimal), enter 0x300.

Advantech PCL-818HG

Advantech PCL-818HG (not recommended)

Board

Advantech PCL-818HG

General Description

The PCL-818 is an I/O board with 16 single or eight differential analog input (A/D) channels (12-bit) with a maximum sample rate of 100 kHz, one analog output (D/A) channel (12-bit), and 16 digital input lines and 16 digital output lines.

The Simulink Real-Time block library supports this board with these driver blocks:

- Advantech PCL-818HG Analog Input (A/D)
- Advantech PCL-818HD Analog Output (D/A)
- Advantech PCL-818HG Digital Input
- Advantech PCL-818HG Digital Output

Board Characteristics

Board name	PCL-818HG
Manufacturer	Advantech
Bus type	ISA
Access method	I/O mapped
Multiple block instance support	Yes
Multiple board support	Yes

Advantech PCL-818HG Analog Input (A/D)

PCL-818HG Analog Input block (not recommended)

Library

Simulink Real-Time Library of Drivers No Longer Recommended for Use

Scaling of Input to Output

Hardware Input	Block Output Data Type	Scaling
Volts	Double	1

Block Parameters

Channel vector

If you select 16 channels (**Input coupling** parameter set to **Single-ended**), enter numbers between 1 and 16. If you select **differential** (**Input coupling** parameter set to **differential**), enter numbers between 1 and 8. For example, to use the first and second analog output (A/D) channels, enter

[1,2]

Number the channels beginning with 1 even if this board manufacturer starts to number the channels with 0.

Range vector

Enter a range code for each of the channels in the channel vector. The range vector must be the same length as the channel vector. This board allows the range of each channel to be different.

The following table is a list of the ranges for this driver and the corresponding range codes.

Input Range (V)	Range Code
-10 to +10	-10

Input Range (V)	Range Code
-5 to +5	-5
-2.5 to +2.5	-2.5
-1.25 to +1.25	-1.25
-0.625 to +0.625	-0.625
0 to +10	10
0 to +1	1
0 to +0.1	0.1
0 to +0.01	0.01

For example, if the first channel is -10 to +10 volts and the second channel is -5 to +5 volts, enter

[-10, -5]

The range settings must correspond to the DIP switch settings on the board.

Input coupling

From the list, select one from the following list of input modes:

- Single-ended channels (16 channels)
- differential channels (8 channels)

Your choice must correspond to the MUX switch setting on the board.

Sample time

Enter the base sample time or a multiple of the base sample time (- 1 means sample time is inherited).

Base address

Enter the base address of the board. This entry must correspond to the DIP switch setting on the board. For example, if the DIP switch setting is 300 (hexadecimal), enter 0x300.

Advantech PCL-818HG Analog Output (D/A)

PCL-818HG Analog Output block (not recommended)

Library

Simulink Real-Time Library of Drivers No Longer Recommended for Use

Scaling of Input to Output

Hardware Output	Block Input Data Type	Scaling
Volts	Double	1

Block Parameters

Range

From the list, choose either 0 - 10V or 0 - 5V.

The range settings must correspond to the DIP switch settings on the board.

Sample time

Enter the base sample time or a multiple of the base sample time (- 1 means sample time is inherited).

Base address

Enter the base address of the board. This entry must correspond to the DIP switch setting on the board. For example, if the DIP switch setting is 300 (hexadecimal), enter 0x300.

Advantech PCL-818HG Digital Input

PCL-818HG Digital Input block (not recommended)

Library

Simulink Real-Time Library of Drivers No Longer Recommended for Use

Scaling of Input to Output

Hardware Input	Block Output Data Type	Scaling
TTL	Double	TTL low = 0.0 TTL high = 1.0

Block Parameters

Channel vector

Enter numbers between 1 and 16. This driver allows the selection of individual digital input lines in arbitrary order. The number of elements defines the number of digital lines you use.

For example, to use the first eight digital inputs, enter

```
[1,2,3,4,5,6,7,8]
```

Number the lines beginning with 1 even if this board manufacturer starts numbering the lines with 0.

Sample time

Enter the base sample time or a multiple of the base sample time (-1 means sample time is inherited).

Base address

Enter the base address of the board. This entry must correspond to the DIP switch setting on the board. For example, if the DIP switch setting is 300 (hexadecimal), enter 0x300.

Advantech PCL-818HG Digital Output

PCL-818HG Digital Output block (not recommended)

Library

Simulink Real-Time Library of Drivers No Longer Recommended for Use

Scaling of Input to Output

Hardware Output	Block Input Data Type	Scaling
TTL	Double	<0.5 = TTL low ≥0.5 = TTL high

Block Parameters

Channel vector

Enter numbers between 1 and 16. This driver allows the selection of individual digital output lines in arbitrary order. The number of elements defines the number of digital lines you use.

For example, to use the first eight digital outputs, enter

```
[1,2,3,4,5,6,7,8]
```

Number the lines beginning with 1 even if this board manufacturer starts numbering the lines with 0.

Sample time

Enter the base sample time or a multiple of the base sample time (-1 means sample time is inherited).

Base address

Enter the base address of the board. This entry must correspond to the DIP switch setting on the board. For example, if the DIP switch setting is 300 (hexadecimal), enter 0x300.

Advantech PCL-818L

Advantech PCL-818L Board (not recommended)

Board

Advantech PCL-818L

General Description

The PCL-818L is an I/O board with 16 single or eight differential analog input (A/D) channels (12-bit) with a maximum sample rate of 40 kHz, one analog output (D/A) channels (12-bit), 16 digital input lines, and 16 digital output lines.

The Simulink Real-Time block library supports this board with these driver blocks:

- Advantech PCL-818L Analog Input (A/D)
- Advantech PCL-818L Analog Output (D/A)
- Advantech PCL-818L Digital Input
- Advantech PCL-818L Digital Output

Board Characteristics

Board name	PCL-818
Manufacturer	Advantech
Bus type	ISA
Access method	I/O mapped
Multiple block instance support	Yes
Multiple board support	Yes

Advantech PCL-818L Analog Input (A/D)

PCL-818L Analog Input block (not recommended)

Library

Simulink Real-Time Library of Drivers No Longer Recommended for Use

Scaling of Input to Output

Hardware Input	Block Output Data Type	Scaling
Volts	Double	1

Block Parameters

Channel vector

If you select 16 channels (**Input coupling** parameter set to **Single-ended**), enter numbers between 1 and 16. If you select **differential** (**Input coupling** parameter set to **differential**), enter numbers between 1 and 8. For example, to use the first and second analog output (A/D) channels, enter

[1,2]

Number the channels beginning with 1 even if this board manufacturer starts to number the channels with 0.

Range vector

Enter a range code for each of the channels in the channel vector. The range vector must be the same length as the channel vector. This board allows the range of each channel to be different.

The following table is a list of the ranges for this driver and the corresponding range codes.

Input Range (V)	Range Code
-5 to +5	-5

Input Range (V)	Range Code
-2.5 to +2.5	-2.5
-1.25 to +1.25	-1.25
-0.625 to +0.625	-0.625

For example, if the first channel is -2.5 to +2.5 volts and the second channel is -5 to +5 volts, enter

[-2.5, -5]

The range settings must correspond to the DIP switch settings on the board.

If you need a -10 to +10 volt range, perform the following workaround. Note that the PCL-818L Analog Input block sets bits G1 and G0 in the board register, but cannot set or read the board jumper.

- 1 On the board, move the JP7 jumper to the 10 volt range (see the manufacturer documentation for details).
- 2 In the **Range vector** parameter, enter [-5].

Setting the JP7 jumper to the 10 volt range doubles all input voltage ranges.

- 3 Use a Gain block to multiply the value by 2. This matches the output voltage to the input voltage for all ranges.

Input coupling

From the list, select one from the following list of input modes:

- Single-ended channels (16 channels)
- differential channels (8 channels)

Your choice must correspond to the MUX switch setting on the board.

Sample time

Enter the base sample time or a multiple of the base sample time (- 1 means sample time is inherited).

Base address

Enter the base address of the board. This entry must correspond to the DIP switch setting on the board. For example, if the DIP switch setting is 300 (hexadecimal), enter 0x300.

Advantech PCL-818L Analog Output (D/A)

PCL-818L Analog Output block (not recommended)

Library

Simulink Real-Time Library of Drivers No Longer Recommended for Use

Scaling of Input to Output

Hardware Output	Block Input Data Type	Scaling
Volts	Double	1

Block Parameters

Range

From the list, choose either 0 - 10V or 0 - 5V.

The range setting must correspond to the DIP switch settings on the board.

Sample time

Enter the base sample time or a multiple of the base sample time (- 1 means sample time is inherited).

Base address

Enter the base address of the board. This entry must correspond to the DIP switch setting on the board. For example, if the DIP switch setting is 300 (hexadecimal), enter 0x300.

Advantech PCL-818L Digital Input

PCL-818L Digital Input block (not recommended)

Library

Simulink Real-Time Library of Drivers No Longer Recommended for Use

Scaling of Input to Output

Hardware Input	Block Output Data Type	Scaling
TTL	Double	TTL low = 0.0 TTL high = 1.0

Block Parameters

Channel vector

Enter channels between 1 and 16. This driver allows the selection of individual digital input lines in arbitrary order. The number of elements defines the number of digital lines you use.

For example, to use the first eight digital inputs, enter

```
[1,2,3,4,5,6,7,8]
```

Number the lines beginning with 1 even if this board manufacturer starts numbering the lines with 0.

Sample time

Enter the base sample time or a multiple of the base sample time (-1 means sample time is inherited).

Base address

Enter the base address of the board. This entry must correspond to the DIP switch setting on the board. For example, if the DIP switch setting is 300 (hexadecimal), enter 0x300.

Advantech PCL-818L Digital Output

PCL-818L Digital Output block (not recommended)

Library

Simulink Real-Time Library of Drivers No Longer Recommended for Use

Scaling of Input to Output

Hardware Output	Block Input Data Type	Scaling
TTL	Double	<0.5 = TTL low ≥0.5 = TTL high

Block Parameters

Channel vector

Enter channels between 1 and 16. This driver allows the selection of individual digital output lines in arbitrary order. The number of elements defines the number of digital lines you use.

For example, to use the first eight digital outputs, enter

```
[1,2,3,4,5,6,7,8]
```

Number the lines beginning with 1 even if this board manufacturer starts numbering the lines with 0.

Sample time

Enter the base sample time or a multiple of the base sample time (-1 means sample time is inherited).

Base address

Enter the base address of the board. This entry must correspond to the DIP switch setting on the board. For example, if the DIP switch setting is 300 (hexadecimal), enter 0x300.

Analogic Drivers No Longer Recommended for Use

Analogic AIM	Analogic AIM board (not recommended)
Analogic AIM12 Analog Input (A/D)	Analogic AIM12 Analog Input block (not recommended)
Analogic AIM12 Digital Input	AIM12 Digital Input block (not recommended)
Analogic AIM12 Digital Output	AIM12 Digital Output (not recommended)
Analogic AIM16	Analogic AIM16 board (not recommended)
Analogic AIM16 Analog Input (A/D)	AIM16 Analog Input block (not recommended)
Analogic AIM16 Digital Input	AIM16 Digital Input block (not recommended)
Analogic AIM16 Digital Output	AIM16 Digital Output (not recommended)

Analogic AIM

Analogic AIM board (not recommended)

Board

Analogic AIM12

General Description

This board comes in three configurations from the factory. The configurations are the AIM12-1/104, the AIM16-1/104, and the AIM16-2/104. The AIM16-1/104 and the AIM16-2/104 differ only in the time required to acquire each sample. The AIM12-1/104 acquires 4 fewer bits, but since the 12 bits are placed in the high 12 bits of the result word, the internal scaling factors are identical to those used with the AIM16. The output of the AIM12 changes in larger steps. Gain settings for the AIM12 are also different than for the AIM16.

When acquiring samples from multiple channels, the board is driven in its burst mode when the highest clock rate available for the board is used. The AIM12-1/104 can acquire 16 channels in 160 microseconds.

The AIM12 board can acquire from 1 to 16 (single ended) channels at each sample time. These channels must be in a contiguous group, starting with an arbitrary **First channel** value and ending with a **Last channel** that must be greater than or equal to **First channel**. A single channel is acquired by setting **First channel** and **Last channel** to the same value.

The choice of unipolar or bipolar conversion range is made by placing jumpers in accordance with the manufacturer documentation. The driver reads the I/O module configuration and adjusts the integer to float conversion accordingly.

The Simulink Real-Time block library supports this board with these driver blocks:

- Analogic AIM12 Analog Input (A/D)
- Analogic AIM12 Digital Input
- Analogic AIM12 Digital Output

Board Characteristics

Board name	AIM12
Manufacturer	Analogic
Bus type	PC/104
Access method	I/O mapped
Multiple block instance support	No
Multiple board support	Yes

Analogic AIM12 Analog Input (A/D)

Analogic AIM12 Analog Input block (not recommended)

Library

Simulink Real-Time Library of Drivers No Longer Recommended for Use

Scaling Input to Output

I/O Module Input	Block Input Data Type	Scaling
Volts	Double	1

Block Parameters

First channel

In **Single-ended (16 channels)** input mode, enter a number between 1 and 16 to indicate the first channel to be acquired. In **Differential (8 channels)** input mode, enter a number between 1 and 8.

Last channel

This is the last channel to acquire. The number must be greater than or equal to the first channel. In **Single-ended (16 channels)** input mode, the number must be less than or equal to 16. In **Differential (8 channels)** input mode, the number must be less than or equal to 8.

Input coupling

From the list, select one from the following list of input modes:

- **Single-ended channels (16 channels)**
- **Differential channels (8 channels)**

Check the manufacturer documentation for wiring configurations.

Gain vector

Enter a vector of gain values with one entry for each channel in the range first channel to last channel. Allowable gain settings for the AIM12 are 1, 10, and 100. If you enter a scalar for gain, this value is used for all channels.

Sample time

Enter the base sample time or a multiple of the base sample time (- 1 means sample time is inherited).

Base address

Enter the base address of the board. This entry must correspond to the DIP switch setting on the board. For example, if the DIP switch setting is 300 (hexadecimal), enter 0x300.

Analogic AIM12 Digital Input

AIM12 Digital Input block (not recommended)

Library

Simulink Real-Time Library of Drivers No Longer Recommended for Use

Scaling Input to Output

I/O Module Input	Block Output Data Type	Scaling
TTL	Double	TTL low = 0.0 TTL high = 1.0

Block Parameters

Channel vector

Enter numbers between 1 and 8 to select the digital input lines to be read. This driver allows the selection of individual digital input lines in arbitrary order. The number of elements defines the number of digital lines used. For example, to use all of the digital inputs enter

[1, 2, 3, 4, 5, 6, 7, 8]

Number the channels beginning with 1 even if this board manufacturer numbers them beginning with 0.

Channel group

Choose **Lower 8 bits** to connect to channels 1 through 8 or **Upper 8 bits** to connect to channels 9 through 16.

Sample time

Enter the base sample time or a multiple of the base sample time (-1 means sample time is inherited).

Base address

Enter the base address of the board. This entry must correspond to the DIP switch setting on the board. For example, if the DIP switch setting is 300 (hexadecimal), enter **0x300**.

Analogic AIM12 Digital Output

AIM12 Digital Output (not recommended)

Library

Simulink Real-Time Library of Drivers No Longer Recommended for Use

Scaling Input to Output

I/O Module Output	Block Input Data Type	Scaling
TTL	Double	< 0.5 = TTL low ≥ 0.5 = TTL high

Block Parameters

Channel vector

Enter numbers between 1 and 8 to select the digital input lines to be read. This driver allows the selection of individual digital input lines in arbitrary order. The number of elements defines the number of digital lines used. For example, to use all of the digital inputs enter

```
[1, 2, 3, 4, 5, 6, 7, 8]
```

Number the channels beginning with 1 even if this board manufacturer numbers them beginning with 0.

Channel group

Choose **Lower 8 bits** to connect to channels 1 through 8 or **Upper 8 bits** to connect to channels 9 through 16.

Sample time

Enter the base sample time or a multiple of the base sample time (-1 means sample time is inherited).

Base address

Enter the base address of the board. This entry must correspond to the DIP switch setting on the board. For example, if the DIP switch setting is 300 (hexadecimal), enter **0x300**.

Analogic AIM16

Analogic AIM16 board (not recommended)

Board

Analogic AIM16

General Description

This board comes in three configurations from the factory. The configurations are the AIM12-1/104, the AIM16-1/104 and the AIM16-2/104. The AIM16-1/104 and the AIM16-2/104 differ only in the time required to acquire each sample. The AIM12-1/104 acquires 4 fewer bits, but since the 12 bits are placed in the high 12 bits of the result word, the internal scaling factors are identical to those used with the AIM16. The output of the AIM12 changes in larger steps. Gain settings for the AIM12 are also different than for the AIM16.

When acquiring samples from multiple channels, the board is driven in its burst mode when the highest clock rate available for the board is used. The AIM16-1/104 can acquire 16 channels in 160 microseconds while the AIM16-2/104 completes the same acquisition in 80 microseconds.

The AIM16 board can acquire from 1 to 16 (single ended) channels at each sample time. These channels must be in a contiguous group, starting with an arbitrary **First channel** value and ending with a **Last channel** that must be greater than or equal to **First channel**. A single channel is acquired by setting **First channel** and **Last channel** to the same value.

The choice of unipolar or bipolar conversion range is made by placing jumpers in accordance with the manufacturer documentation. The driver reads the I/O module configuration and adjusts the integer to float conversion accordingly.

The Simulink Real-Time block library supports this board with these driver blocks:

- Analogic AIM16 Analog Input (A/D)
- Analogic AIM16 Digital Input

- Analogic AIM16 Digital Output

Board Characteristics

Board name	AIM16
Manufacturer	Analogic
Bus type	PC/104
Access method	I/O mapped
Multiple block instance support	No
Multiple board support	Yes

Analogic AIM16 Analog Input (A/D)

AIM16 Analog Input block (not recommended)

Library

Simulink Real-Time Library of Drivers No Longer Recommended for Use

Scaling Input to Output

I/O Module Input	Block Input Data Type	Scaling
Volts	Double	1

Block Parameters

First channel

In **Single-ended (16 channels)** input mode, enter a number between 1 and 16 to indicate the first channel to be acquired. In **Differential (8 channels)** input mode, enter a number between 1 and 8.

Last channel

This is the last channel to acquire. The number must be greater than or equal to the first channel. In **Single-ended (16 channels)** input mode, the number must be less than or equal to 16. In **Differential (8 channels)** input mode, the number must be less than or equal to 8.

Input coupling

From the list, select one from the following list of input modes:

- **Single-ended channels (16 channels)**
- **Differential channels (8 channels)**

Check the manufacturer documentation for wiring configurations.

Gain vector

Enter a vector of gain values with one entry for each channel in the range first channel to last channel. Allowable gain settings for the AIM16 are 1, 2, 4, and 8. If you enter a scalar for gain, this gain value is used for all channels.

Sample time

Enter the base sample time or a multiple of the base sample time (- 1 means sample time is inherited).

Base address

Enter the base address of the board. This entry must correspond to the DIP switch setting on the board. For example, if the DIP switch setting is 300 (hexadecimal), enter 0x300.

Analogic AIM16 Digital Input

AIM16 Digital Input block (not recommended)

Library

Simulink Real-Time Library of Drivers No Longer Recommended for Use

Scaling Input to Output

I/O Module Input	Block Output Data Type	Scaling
TTL	Double	TTL low = 0.0 TTL high = 1.0

Block Parameters

Channel vector

Enter numbers between 1 and 8 to select the digital input lines to be read. This driver allows the selection of individual digital input lines in arbitrary order. The number of elements defines the number of digital lines used. For example, to use all of the digital inputs enter

[1, 2, 3, 4, 5, 6, 7, 8]

Number the channels beginning with 1 even if this board manufacturer numbers them beginning with 0.

Channel group

Choose **Lower 8 bits** to connect to channels 1 through 8 or **Upper 8 bits** to connect to channels 9 through 16.

Sample time

Enter the base sample time or a multiple of the base sample time (-1 means sample time is inherited).

Base address

Enter the base address of the board. This entry must correspond to the DIP switch setting on the board. For example, if the DIP switch setting is 300 (hexadecimal), enter **0x300**.

Analogic AIM16 Digital Output

AIM16 Digital Output (not recommended)

Library

Simulink Real-Time Library of Drivers No Longer Recommended for Use

Scaling Input to Output

I/O Module Output	Block Input Data Type	Scaling
TTL	Double	< 0.5 = TTL low ≥ 0.5 = TTL high

Block Parameters

Channel vector

Enter numbers between 1 and 8 to select the digital input lines to be read. This driver allows the selection of individual digital input lines in arbitrary order. The number of elements defines the number of digital lines used. For example, to use all of the digital inputs enter

```
[1, 2, 3, 4, 5, 6, 7, 8]
```

Number the channels beginning with 1 even if this board manufacturer numbers them beginning with 0.

Channel group

Choose **Lower 8 bits** to connect to channels 1 through 8 or **Upper 8 bits** to connect to channels 9 through 16.

Sample time

Enter the base sample time or a multiple of the base sample time (-1 means sample time is inherited).

Base address

Enter the base address of the board. This entry must correspond to the DIP switch setting on the board. For example, if the DIP switch setting is 300 (hexadecimal), enter **0x300**.

BittWare Drivers No Longer Recommended for Use

BittWare Audio-PMC+

Support for BittWare Audio PMC+ board
(not recommended)

BittWare Audio-PMC+ Analog Input

Audio-PMC+ Analog Input block (not
recommended)

BittWare Audio-PMC+ Analog Output

Audio-PMC+ Analog Output block (not
recommended)

BittWare Audio-PMC+

Support for BittWare Audio PMC+ board (not recommended)

Board

BittWare Audio-PMC+

Library

Simulink Real-Time Library of Drivers No Longer Recommended for Use

General Description

The Audio-PMC+ board is an audio board with 8 I/O channels.

The Simulink Real-Time block library supports this board with these driver blocks:

- BittWare Audio-PMC+ Analog Input
- BittWare Audio-PMC+ Analog Output

Block parameters for the input and output blocks appear the same.

Board Characteristics

Board name	Audio-PMC+
Manufacturer	BittWare
Bus type	PCI
Access method	Memory mapped
Multiple block instance support	No
Multiple board support	No

Features

- Input and output are in the form of the DSP System Toolbox frame signal type when the frame is larger than a single sample.
- The analog input block outputs a **double** or 32 bit **integer** frame of data.
- The Audio-PMC+ board performs acquisition simultaneously for all the selected channels in a model.
- The analog output block is dynamically typed. The **integer** or **double** data type is taken from the connection instead of a block parameter.

Hardware Installation Notes

The Audio-PMC+ daughter board might come from BittWare with jumpers installed to start from an onboard ROM. You must remove these jumpers, as follows:

- 1** Remove the Audio-PMC+ from the carrier board and look for 6 pairs of pins along one edge.
- 2** If one or more pairs are jumpered, then remove each jumper and reinstall it with only one pin connected. Leave the other side of the jumper hanging. This keeps the jumper available if you want to reset the jumpers to allow the board to start from ROM.

BitWare Audio-PMC+ Analog Input

Audio-PMC+ Analog Input block (not recommended)

Library

Simulink Real-Time Library of Drivers No Longer Recommended for Use

Block Parameters

Channel Vector

This is a vector of channels. Specifies the input channels that the block works on. For example, to use the first, third, and fifth analog input channels, enter

[1,3,5]

Output Format

Specify the format that the data takes. The choices are

- A normalized **double** in the range from -1.0 to 1.0
- An unscaled **integer**

The unscaled integer format is usable with blocks that can accept fixed point data. This format contains the data in the lower 24 bits of a 32 bit **integer** with sign extension in the upper 8 bits.

Note: You can only set this parameter for the analog input block. The analog output block determines the data type from the connection and sets itself to the required type.

Frame Size, Sample Rate, and Sampletime

These three parameters are not independent but are related by

$$FrameSize = Sampletime * SampleRate.$$

After you specify two of the parameters, the equation determines the third parameter.

For example, if you set **Frame Size** to 32 and **Sample Rate** to 40000, specify **Sampletime** as -1. It is computed internally to 0.0008 seconds. This example model will execute every 0.0008 seconds, which is every 32 samples at 40 kHz.

Conversely, you can also specify that you want to execute every 1.0 ms with a **Frame Size** of 64 samples. Specify **Sample Rate** as -1. It is computed to be 64000 Hz.

The implementation of **Sample Rate** on the Audio-PMC+ might cause the rate on your board to be inexact. Audio-PMC+ derives the sample rate from the PWM0 output of the first 21065L SHARC[®] DSP chip. The PWM0 output is driven by the 60 MHz CPU clock for sample rates between 100 kHz and 20 kHz and by a prescaled 30 MHz CPU clock (half the 60 MHz CPU clock) for sample rates between 8 kHz and 20 kHz.

The sample rate is implemented internally by specifying the total number of counts per sample interval. For example, the number of counts for a sample rate of 44.1 kHz is calculated as

$$60 \times 10^6 / 44.1 \times 10^3 = 1360.544217.$$

This value is rounded down to **1360**. To calculate the actual clock sample rate, divide 60 MHz by the number of counts

$$60 \times 10^6 / 1360 = 44117.647.$$

The result indicates that the sample rate is off by 0.04%. This calculation assumes that the CPU clock is exactly 60 MHz.

Since you can build a model with just input or just output, the three rate parameters are included in both block parameter dialogs. You must set them to equal values if you have a model that has both. If they are not equal, you will get an error when you try to build the model.

The practical limit on **Sample Rate** is

$$8000 \leq \text{SampleRate} \leq 100000.$$

Below 8 kHz, the output digital filter does not seem to work, although the converter continues to work there.

Frame Size values can be between 1 and 256. If the specified or computed frame size exceeds 256, the driver will return an error during initialization.

PCI slot (-1:autosearch)

If only one board of this type is in the target computer, enter - 1 to locate the board.

If two or more boards of this type are in the target computer, enter the bus number and the PCI slot number of the board associated with this driver block. Use the format **[BusNumber,SlotNumber]**.

To determine the bus number and the PCI slot number, type:

```
tg = slrt;  
getPCIInfo(tg, 'installed')
```

Note: The use of multiple boards, at the same time and in the same model, is unsupported.

See Also

“Running Models with BittWare Blocks” on page 30-2

BittWare Audio-PMC+ Analog Output

Audio-PMC+ Analog Output block (not recommended)

Library

Simulink Real-Time Library of Drivers No Longer Recommended for Use

Block Parameters

Channel Vector

This is a vector of channels. Specifies the output channels that the block works on. For example, to use the first, third, and fifth analog output channels, enter

```
[1,3,5]
```

Frame Size, Sample Rate, and Sampletime

These three parameters are not independent but are related by

$$\text{FrameSize} = \text{Sampletime} * \text{SampleRate}.$$

After you specify two of the parameters, the equation determines the third parameter.

For example, if you set **Frame Size** to 32 and **Sample Rate** to 40000, specify **Sampletime** as -1. It is computed internally to 0.0008 seconds. This example model will execute every 0.0008 seconds, which is every 32 samples at 40 kHz.

Conversely, you can also specify that you want to execute every 1.0 ms with a **Frame Size** of 64 samples. Specify **Sample Rate** as -1. It is computed to be 64000 Hz.

The implementation of **Sample Rate** on the Audio-PMC+ might cause the rate on your board to be inexact. Audio-PMC+ derives the sample rate from the PWM0 output of the first 21065L SHARC DSP chip. The PWM0 output is driven by the 60 MHz CPU clock for sample rates between 100 kHz and 20 kHz and by a prescaled 30 MHz CPU clock (half the 60 MHz CPU clock) for sample rates between 8 kHz and 20 kHz.

The sample rate is implemented internally by specifying the total number of counts per sample interval. For example, the number of counts for a sample rate of 44.1 kHz is calculated as

$$60 \times 10^6 / 44.1 \times 10^3 = 1360.544217.$$

This value is rounded down to **1360**. To calculate the actual clock sample rate, divide 60 MHz by the number of counts

$$60 \times 10^6 / 1360 = 44117.647.$$

The result indicates that the sample rate is off by 0.04%. This calculation assumes that the CPU clock is exactly 60 MHz.

Since you can build a model with just input or just output, the three rate parameters are included in both block parameter dialogs. You must set them to equal values if you have a model that has both. If they are not equal, you will get an error when you try to build the model.

The practical limit on **Sample Rate** is

$$8000 \leq \text{SampleRate} \leq 100000.$$

Below 8 kHz, the output digital filter does not seem to work, although the converter continues to work there.

Frame Size values can be between **1** and **256**. If the specified or computed frame size exceeds **256**, the driver will return an error during initialization.

PCI slot (-1:autosearch)

If only one board of this type is in the target computer, enter **-1** to locate the board.

If two or more boards of this type are in the target computer, enter the bus number and the PCI slot number of the board associated with this driver block. Use the format **[BusNumber,SlotNumber]**.

To determine the bus number and the PCI slot number, type:

```
tg = slrt;
getPCIInfo(tg, 'installed')
```

Note: The use of multiple boards, at the same time and in the same model, is not supported.

See Also

“Running Models with BittWare Blocks” on page 30-2

Diamond Drivers No Longer Recommended for Use

Diamond Quartz-MM-10	Diamond Systems Quartz-MM-10 board (not recommended)
Diamond Quartz-MM-10 Counter PWM & ARM	Quartz-MM-10 Counter PWM & ARM block (not recommended)
Diamond Quartz-MM-10 Counter FM	Quartz-MM-10 Counter FM block (not recommended)
Diamond Quartz-MM-10 Counter FM & ARM	Quartz-MM-10 Counter FM & ARM block (not recommended)
Diamond Quartz-MM-10 PWM Capture	Quartz-MM-10 PWM Capture block (not recommended)
Diamond Quartz-MM-10 FM Capture	Quartz-MM-10 FM Capture block (not recommended)
Diamond Quartz-MM-5	Diamond Systems Quartz-MM-5 board (not recommended)
Diamond Quartz-MM-5 Counter PWM	Quartz-MM-5 Counter PWM block (not recommended)
Diamond Quartz-MM-5 Counter PWM & ARM	Quartz-MM-5 Counter PWM & ARM block (not recommended)
Diamond Quartz-MM-5 Counter FM	Quartz-MM-5 Counter FM block (not recommended)
Diamond Quartz-MM-5 Counter FM & ARM	Quartz-MM-5 Counter FM & ARM block (not recommended)
Diamond Quartz-MM-5 PWM Capture	Quartz-MM-5 PWM Capture block (not recommended)

Diamond Quartz-MM-5 FM Capture

Quartz-MM-5 FM Capture block (not recommended)

Diamond Quartz-MMxx

Diamond Quartz-MMxx block (not recommended)

Diamond Quartz-MM-10

Diamond Systems Quartz-MM-10 board (not recommended)

Board

Diamond Quartz-MM-10

General Description

The Quartz-MM 10 has eight digital input line, eight digital output lines, and 10 counter/timers.

The Simulink Real-Time product supports this board with these driver blocks:

- Diamond Quartz-MM-10 Counter PWM
- Diamond Quartz-MM-10 Counter PWM & ARM
- Diamond Quartz-MM-10 Counter FM
- Diamond Quartz-MM-10 Counter FM & ARM
- Diamond Quartz-MM-10 PWM Capture
- Diamond Quartz-MM-10 FM Capture
- Diamond Quartz-MMxx

Board Characteristics

Board name	Quartz-MM-10
Manufacturer	Diamond Systems Corporation
Bus type	PC/104
Access method	I/O mapped
Multiple block instance support	Yes — a channel can be accessed by at most one block
Multiple board support	Yes

Diamond Quartz-MM-10 Counter PWM

Quartz-MM-10 Counter PWM block (not recommended)

Library

Simulink Real-Time Library of Drivers No Longer Recommended for Use

Note

The Quartz-MM10 has two AM9513A chips with five counters each.

The Quartz-MM10 PWM driver programs the AM9513A for PWM (pulse width modulation) signal generation (a square wave with fixed frequency and variable duty cycle). The block has one input that defines the variable duty cycle between 0 and 1. For the corresponding counter channel, the PWM signal is output at the pin named OUT.

Scaling Input to Output

Hardware Output	Block Input Data Type	Scaling
TTL	Double	0 to 1

Block Parameters

Counter

From the list, choose 1, 2, 3, 4, or 5 to select which counter is used with this driver block. One block is required for each counter used.

Frequency base

From the list, choose F1=4MHz, F2=400kHz, F3=40kHz, F4=4kHz, or F5=400Hz to set the base frequency.

Relative output frequency

Enter a value between 0 and 0.25. The **Relative output frequency** is multiplied by the **Frequency base** to set the fixed output frequency of the PWM signal.

For example, if the output frequency of a square wave must be 17.5 kHz, then choose $F_2=400\text{kHz}$ as the **Frequency base** and enter 0.04375 as the **Relative output frequency**. $400\text{ kHz} \times 0.04375 = 17.5\text{ kHz}$

Level sequence of square wave

From the list, choose either **high-low** or **low-high**:

- If you choose **high-low**, the square wave period starts with the TTL high part followed by the TTL low part.
- If you choose **low-high**, the square wave period starts with the TTL low part followed by the TTL high part.

In either case, the duty cycle entering the block defines the duration of the TTL high part.

Level when disarmed

From the list, choose either **high** or **low**. The counter is automatically disarmed when the real-time application is not running and becomes armed when the application begins running. This parameter sets the TTL level when the counter is disarmed.

Sample time

Enter the base sample time or a multiple of the base sample time. The sample time indicates the update rate of registration on the input (duty cycle)

Base address

Enter the base address of the board. This entry must correspond to the DIP switch setting on the board. For example, if the DIP switch setting is 300 (hexadecimal), enter **0x300**.

Diamond Quartz-MM-10 Counter PWM & ARM

Quartz-MM-10 Counter PWM & ARM block (not recommended)

Library

Simulink Real-Time Library of Drivers No Longer Recommended for Use

Note

The Quartz-MM 10 has two AM9513A chips with five counters.

The Quartz-MM 10 PWM & ARM driver programs the AM9513A for PWM or disarmed signal generation (a square wave with fixed frequency and variable duty cycle). Additionally the driver allows you to arm and disarm the counter by using the second block input. For the corresponding counter channel, the PWM signal is output at the pin named OUT.

Scaling Input to Output

Hardware Output	Block Input Data Type	Scaling
TTL	Duty cycle: Double Arm: Double	0 to 1 <0.5 disarmed ≥0.5 armed

Block Parameters

Counter

From the list, choose 1, 2, 3, 4, or 5 to select which counter is used with this driver block. One block is required for each counter used.

Frequency base

From the list, choose F1=4MHz, F2=400kHz, F3=40kHz, F4=4kHz, or F5=400Hz to set the base frequency.

Relative output frequency

Enter a value between 0 and 0.25. The **Relative output frequency** is multiplied by the **Frequency base** to set the fixed output frequency of the PWM signal.

For example, if the output frequency of a square wave must be 17.5 kHz, then choose F2=400kHz as the **Frequency base** and enter 0.04375 as the **Relative output frequency**. $400 \text{ kHz} \times 0.04375 = 17.5 \text{ kHz}$

Level sequence of square wave

From the list, choose either **high-low** or **low-high**:

- If you choose **high-low**, the square wave period starts with the TTL high part followed by the TTL low part.
- If you choose **low-high**, the square wave period starts with the TTL low part followed by the TTL high part.

In either case, the duty cycle entering the block defines the duration of the TTL high part.

Level when disarmed

From the list, choose either **high** or **low**. The counter is automatically disarmed when the real-time application is not running. If the application is running, the second input port controls whether the counter is armed or disarmed. This parameter sets the TTL level when the counter is disarmed.

Sample time

Enter the base sample time or a multiple of the base sample time. The sample time indicates the update rate of registration on the input (duty cycle)

Base address

Enter the base address of the board. This entry must correspond to the DIP switch setting on the board. For example, if the DIP switch setting is 300 (hexadecimal), enter 0x300.

Diamond Quartz-MM-10 Counter FM

Quartz-MM-10 Counter FM block (not recommended)

Library

Simulink Real-Time Library of Drivers No Longer Recommended for Use

Note

The Quartz-MM10 has two AM9513A chips with five counters.

The Quartz-MM10 FM driver programs the AM9513A for FM (frequency modulation) signal generation (a square wave with fixed duty cycle and variable frequency). For the corresponding counter channel, the FM signal is output at the pin named OUT.

Scaling Input to Output

Hardware Output	Block Input Data Type	Scaling
TTL	Double	0 to 1

Block Parameters

Counter

From the list, choose 1, 2, 3, 4, or 5 to select which counter is used with this driver block. One block is required for each counter used.

Frequency base

From the list, choose F1=4MHz, F2=400kHz, F3=40kHz, F4=4kHz, or F5=400Hz to set the base frequency.

Output duty cycle

Enter a value between 0 and 1 to set the duty cycle of the square wave. The duty cycle is held fixed during execution of the real-time application.

Note: Your control over the output duty cycle is not precise. See “PWM and FM Driver Block Notes” on page 1-9 for details.

Level sequence of square wave

From the list, choose either **high-low** or **low-high**:

- If you choose **high-low**, the square wave period starts with the TTL high part followed by the TTL low part.
- If you choose **low-high**, the square wave period starts with the TTL low part followed by the TTL high part.

In either case, the duty cycle entering the block defines the duration of the TTL high part.

Level when disarmed

From the list, choose either **high** or **low**. The counter is automatically disarmed when the real-time application is not running and becomes armed when the application begins running. This parameter sets the TTL level when the counter is disarmed.

Sample time

Enter the base sample time or a multiple of the base sample time. The sample time indicates the update rate of registration on the input (duty cycle)

Base address

Enter the base address of the board. This entry must correspond to the DIP switch setting on the board. For example, if the DIP switch setting is 300 (hexadecimal), enter **0x300**.

Diamond Quartz-MM-10 Counter FM & ARM

Quartz-MM-10 Counter FM & ARM block (not recommended)

Library

Simulink Real-Time Library of Drivers No Longer Recommended for Use

Note

The Quartz-MM 10 has two AM9513A chips with five counters.

The Quartz-MM 10 FM & ARM driver programs the AM9513A for FM (frequency modulation) signal generation (a square wave with fixed duty cycle and variable frequency). Additionally the driver allows you to arm and disarm the counter by the second block input. For the corresponding counter channel, the FM signal is output at the pin named OUT.

Scaling Input to Output

Hardware Output	Block Input Data Type	Scaling
TTL	Variable frequency: Double Arm: Double	<0.5 disarmed ≥0.5 armed

Block Parameters

Counter

From the list, choose 1, 2, 3, 4, 5, 6, 7, 8, 9, or 10 to select which counter is used with this driver block. One block is required for each counter used.

Frequency base

From the list, choose F1=4MHz, F2=400kHz, F3=40kHz, F4=4kHz, or F5=400Hz to set the base frequency.

Output duty cycle

Enter a value between 0 and 1 to set the duty cycle of the square wave. The duty cycle is held fixed during execution of the real-time application.

Note: Your control over the output duty cycle is not precise. See “PWM and FM Driver Block Notes” on page 1-9 for details.

Level sequence of square wave

From the list, choose either **high-low** or **low-high**:

- If you choose **high-low**, the square wave period starts with the TTL high part followed by the TTL low part.
- If you choose **low-high**, the square wave period starts with the TTL low part followed by the TTL high part.

In either case, the **Output duty cycle** defined in the setting above defines the duration of the TTL high part.

Level when disarmed

From the list, choose either **high** or **low**. The counter is automatically disarmed when the real-time application is not running. If the application is running, the second input port controls whether the counter is armed or disarmed. This parameter sets the TTL level when the counter is disarmed.

Sample time

Enter the base sample time or a multiple of the base sample time. The sample time indicates the update rate of registration on the input (duty cycle).

Base address

Enter the base address of the board. This entry must correspond to the DIP switch setting on the board. For example, if the DIP switch setting is 300 (hexadecimal), enter **0x300**.

Diamond Quartz-MM-10 PWM Capture

Quartz-MM-10 PWM Capture block (not recommended)

Library

Simulink Real-Time Library of Drivers No Longer Recommended for Use

Note

This block programs the AM9513A for capturing PWM signals by using two counters. One counter measures the cycle duration, and the other counter measures the length of time the signal is high.

There are two outputs. One output is the relative frequency compared to the base frequency. The other output is the duty cycle. To get the actual frequency, multiply the base frequency by the relative frequency.

The PWM signal must enter the pins of both corresponding counter channels (parallel wiring) named GATE. Leave both IN pins unconnected.

Scaling Input to Output

Hardware Output	Block Input Data Type	Scaling
TTL	Double	0 to 1

Block Parameters

Counter

From the list, choose 1&2, 2&3, 3&4, 4&5, 6&7, 7&8, 8&9, or 9&10. This selects which two counters the driver block uses to determine the PWM. Use one block for each pair of counters. No two blocks should use the same counter. For example, use counters 1&2 for one block and 3&4 for a second block. Do not use a combination like 1&2 and 2&3.

Frequency base

From the list, choose F1=4MHz, F2=400kHz, F3=40kHz, F4=4kHz, or F5=400Hz to set the base frequency.

Sample time

Enter the base sample time or a multiple of the base sample time. The sample time indicates the update rate of registration on the input (duty cycle)

Base address

Enter the base address of the board. This entry must correspond to the DIP switch setting on the board. For example, if the DIP switch setting is 300 (hexadecimal), enter 0x300.

Diamond Quartz-MM-10 FM Capture

Quartz-MM-10 FM Capture block (not recommended)

Library

Simulink Real-Time Library of Drivers No Longer Recommended for Use

Note

This block programs the AM9513A for capturing FM signals.

There is one output for relative frequency compared to the base frequency. To get the actual frequency, multiply the base frequency by the relative frequency.

The FM signal must enter the pin of the corresponding counter channel named GATE. Leave the IN pin unconnected.

Scaling Input to Output

Hardware Output	Block Input Data Type	Scaling
TTL	Double	0 to 1

Block Parameters

Counter

From the list, choose 1, 2, 3, 4, 5, 6, 7, 8, 9, or 10. This selects which counter the driver block uses to determine the FM. One block is required for each counter used.

Frequency base

From the list, choose F1=4MHz, F2=400kHz, F3=40kHz, F4=4kHz, or F5=400Hz to set the base frequency.

Sample time

Enter the base sample time or a multiple of the base sample time. The sample time indicates the update rate of registration on the input (duty cycle).

Base address

Enter the base address of the board. This entry must correspond to the DIP switch setting on the board. For example, if the DIP switch setting is 300 (hexadecimal), enter **0x300**.

Diamond Quartz-MM-5

Diamond Systems Quartz-MM-5 board (not recommended)

Board

Diamond Quartz-MM-5

General Description

The Quartz-MM 5 has 8 digital input lines, 8 digital output lines.

The Simulink Real-Time product supports this board with these driver blocks:

- Diamond Quartz-MM-5 Counter PWM
- Diamond Quartz-MM-5 Counter PWM & ARM
- Diamond Quartz-MM-5 Counter FM
- Diamond Quartz-MM-5 Counter FM & ARM
- Diamond Quartz-MM-5 PWM Capture
- Diamond Quartz-MM-5 FM Capture
- Diamond Quartz-MMxx

Board Characteristics

Board name	Quartz-MM-5
Manufacturer	Diamond Systems Corporation
Bus type	PC/104
Access method	I/O mapped
Multiple block instance support	Yes — a channel can be accessed by at most one block
Multiple board support	Yes

Diamond Quartz-MM-5 Counter PWM

Quartz-MM-5 Counter PWM block (not recommended)

Library

Simulink Real-Time Library of Drivers No Longer Recommended for Use

Note

The Quartz-MM5 has one AM9513A chip with 5 counters.

The Quartz-MM5 PWM driver programs the AM9513A for PWM (Pulse Width Modulation) signal generation (a square wave with fixed frequency and variable duty cycle). The block has one input which defines the variable duty cycle between 0 and 1. For the corresponding counter channel, the PWM signal is output at the pin named OUT.

Scaling Input to Output

Hardware Output	Block Input Data Type	Scaling
TTL	Double	0 to 1

Block Parameters

Counter

From the list, choose 1, 2, 3, or 4 to select which counter is used with this driver block. One block is required for each counter used.

Frequency base

From the list, choose F1=4MHz, F2=400kHz, F3=40kHz, F4=4kHz, or F5=400Hz to set the base frequency.

Relative output frequency

Enter a value between 0 and 0.25. The **Relative output frequency** is multiplied by the **Frequency base** to set the fixed output frequency of the PWM-signal.

For example, if the output frequency of a square wave has to be 17.5 kHz, then choose $F_2=400\text{kHz}$ as the **Frequency base** and enter 0.04375 as the **Relative output frequency**. $400\text{ kHz} \times 0.04375 = 17.5\text{ kHz}$

Note: Your control over the output frequency is not precise. See “PWM and FM Driver Block Notes” on page 1-9 for details.

Level sequence of square wave

From the list, choose either **high-low** or **low-high**:

- If you choose **high-low**, the square wave period starts with the TTL high part followed by the TTL low part.
- If you choose **low-high**, the square wave period starts with the TTL low part followed by the TTL high part.

In either case, the duty cycle entering the block defines the duration of the TTL high part.

Level when disarmed

From the list, choose either **high** or **low**. The counter is automatically disarmed when the real-time application is not running and gets armed when the application begins running. This parameter sets the TTL level when the counter is disarmed.

Sample time

Enter the base sample time or a multiple of the base sample time. The sample time indicates the update rate of registration on the input (Duty Cycle)

Base address

Enter the base address of the board. This entry must correspond to the DIP switch setting on the board. For example, if the DIP switch setting is 300 (hexadecimal), enter **0x300**.

Diamond Quartz-MM-5 Counter PWM & ARM

Quartz-MM-5 Counter PWM & ARM block (not recommended)

Library

Simulink Real-Time Library of Drivers No Longer Recommended for Use

Note

The Quartz-MM5 has one AM9513A chip with 5 counters.

The Quartz-MM5 PWM & ARM driver programs the AM9513A for PWM or disarmed signal generation (a square wave with fixed frequency and variable duty cycle). Additionally the driver allows to arm and disarm the counter by the second block input. For the corresponding counter channel, the PWM signal is output at the pin named OUT.

Scaling Input to Output

Hardware Output	Block Input Data Type	Scaling
TTL	Duty cycle: Double Arm: Double	0 to 1 <0.5 disarmed ≥0.5 armed

Block Parameters

Counter

From the list, choose 1, 2, 3, 4, or 5 to select which counter is used with this driver block. One block is required for each counter used.

Frequency base

From the list, choose F1=4MHz, F2=400kHz, F3=40kHz, F4=4kHz, or F5=400Hz to set the base frequency.

Relative output frequency

Enter a value between 0 and 0.25. The **Relative output frequency** is multiplied by the **Frequency base** to set the fixed output frequency of the PWM-signal.

For example, if the output frequency of a square wave has to be 17.5 kHz, then choose $F_2=400\text{kHz}$ as the **Frequency base** and enter 0.04375 as the **Relative output frequency**. $400\text{ kHz} \times 0.04375 = 17.5\text{ kHz}$

Level sequence of square wave

From the list, choose either **high-low** or **low-high**:

- If you choose **high-low**, the square wave period starts with the TTL high part followed by the TTL low part.
- If you choose **low-high**, the square wave period starts with the TTL low part followed by the TTL high part.

In either case, the duty cycle entering the block defines the duration of the TTL high part.

Level when disarmed

From the list, choose either **high** or **low**. The counter is automatically disarmed when the real-time application is not running. If the application is running, the second input port controls whether the counter is armed or disarmed. This parameter sets the TTL level when the counter is disarmed.

Sample time

Enter the base sample time or a multiple of the base sample time. The sample time indicates the update rate of registration on the input (Duty Cycle)

Base address

Enter the base address of the board. This entry must correspond to the DIP switch setting on the board. For example, if the DIP switch setting is 300 (hexadecimal), enter 0x300.

Diamond Quartz-MM-5 Counter FM

Quartz-MM-5 Counter FM block (not recommended)

Library

Simulink Real-Time Library of Drivers No Longer Recommended for Use

Note

The Quartz-MM5 has one AM9513A chip with 5 counters.

The Quartz-MM5 FM driver programs the AM9513A for FM (Frequency Modulation) signal generation (a square wave with fixed duty cycle and variable frequency). For the corresponding counter channel, the PWM signal is output at the pin named OUT.

Scaling Input to Output

Hardware Output	Block Input Data Type	Scaling
TTL	Double	0 to 1

Block Parameters

Counter

From the list, choose 1, 2, 3, 4, or 5 to select which counter is used with this driver block. One block is required for each counter used.

Frequency base

From the list, choose F1=4MHz, F2=400kHz, F3=40kHz, F4=4kHz, or F5=400Hz to set the base frequency.

Output duty cycle

Enter a value between 0 and 1 to set the duty cycle of the square wave. The Duty Cycle is held fixed during execution of the real-time application.

Level sequence of square wave

From the list, choose either **high-low** or **low-high**:

- If you choose **high-low**, the square wave period starts with the TTL high part followed by the TTL low part.
- If you choose **low-high**, the square wave period starts with the TTL low part followed by the TTL high part.

In either case, the duty cycle entering the block defines the duration of the TTL high part.

Level when disarmed

From the list, choose either **high** or **low**. The counter is automatically disarmed when the real-time application is not running and gets armed when the application begins running. This parameter sets the TTL level when the counter is disarmed.

Sample time

Enter the base sample time or a multiple of the base sample time. The sample time indicates the update rate of registration on the input (Duty Cycle)

Base address

Enter the base address of the board. This entry must correspond to the DIP switch setting on the board. For example, if the DIP switch setting is 300 (hexadecimal), enter **0x300**.

Diamond Quartz-MM-5 Counter FM & ARM

Quartz-MM-5 Counter FM & ARM block (not recommended)

Library

Simulink Real-Time Library of Drivers No Longer Recommended for Use

Note

The Quartz-MM5 has one AM9513A chip with 5 counters.

The Quartz-MM5 FM & ARM driver programs the AM9513A for FM (Frequency Modulation) signal generation (a square wave with fixed duty cycle and variable frequency). Additionally the driver allows to arm and disarm the counter by the second block input. For the corresponding counter channel, the PWM signal is output at the pin named OUT.

Scaling Input to Output

Hardware Output	Block Input Data Type	Scaling
TTL	Variable frequency: Double Arm: Double	<0.5 disarmed ≥0.5 armed

Block Parameters

Counter

From the list, choose 1, 2, 3, 4, 5, 6, 7, 8, 9, or 10 to select which counter is used with this driver block. One block is required for each counter used.

Frequency base

From the list, choose F1=4MHz, F2=400kHz, F3=40kHz, F4=4kHz, or F5=400Hz to set the base frequency.

Output duty cycle

Enter a value between 0 and 1 to set the duty cycle of the square wave. The Duty Cycle is held fixed during execution of the real-time application.

Note: Your control over the output duty cycle is not precise. See “PWM and FM Driver Block Notes” on page 1-9 for details.

Level sequence of square wave

From the list, choose either **high-low** or **low-high**:

- If you choose **high-low**, the square wave period starts with the TTL high part followed by the TTL low part.
- If you choose **low-high**, the square wave period starts with the TTL low part followed by the TTL high part.

Level when disarmed

From the list, choose either **high** or **low**. The counter is automatically disarmed when the real-time application is not running. If the application is running, the second input port controls whether the counter is armed or disarmed. This parameter sets the TTL level when the counter is disarmed.

Sample time

Enter the base sample time or a multiple of the base sample time. The sample time indicates the update rate of registration on the input (Duty Cycle)

Base address

Enter the base address of the board. This entry must correspond to the DIP switch setting on the board. For example, if the DIP switch setting is 300 (hexadecimal), enter **0x300**.

Diamond Quartz-MM-5 PWM Capture

Quartz-MM-5 PWM Capture block (not recommended)

Library

Simulink Real-Time Library of Drivers No Longer Recommended for Use

Note

This block programs the AMD9513A for capturing PWM signals by using two counters. One counter measures the cycle duration, and the other counter measures the duration the signal is high.

There are two outputs. One output is the relative frequency compared to the base frequency. The other output is the duty cycle. To get the actual frequency, multiply the base frequency by the relative frequency.

The PWM signal has to enter the pins named GATE of both corresponding counter channels (parallel wiring). Leave both IN pins unconnected.

Scaling Input to Output

Hardware Output	Block Input Data Type	Scaling
TTL	Double	0 to 1

Block Parameters

Counter

From the list, choose 1&2, 2&3, 3&4, or 4&5. This selects which two counters the driver block uses to determine the PWM. Use one block for each pair of counters. No two blocks should use the same counter. For example, use counters 1&2 for one block and 3&4 for a second block. Do not use a combination like 1&2 and 2&3.

Frequency base

From the list, choose F1=4MHz, F2=400kHz, F3=40kHz, F4=4kHz, or F5=400Hz to set the base frequency.

Sample time

Enter the base sample time or a multiple of the base sample time. The sample time indicates the update rate of registration on the input (Duty Cycle)

Base address

Enter the base address of the board. This entry must correspond to the DIP switch setting on the board. For example, if the DIP switch setting is 300 (hexadecimal), enter 0x300.

Diamond Quartz-MM-5 FM Capture

Quartz-MM-5 FM Capture block (not recommended)

Library

Simulink Real-Time Library of Drivers No Longer Recommended for Use

Note

This block programs the AMD9513A for capturing FM signals.

There is one output for relative frequency compared to the base frequency. To get the actual frequency, multiply the base frequency by the relative frequency.

The FM signal has to enter the pin named GATE of the corresponding counter channel. Leave the IN pin unconnected.

Scaling Input to Output

Hardware Output	Block Input Data Type	Scaling
TTL	Double	0 to 1

Block Parameters

Counter

From the list, choose 1, 2, 3, 4 or 5. This selects which counter the driver block uses to determine the FM. One block is required for each counter used.

Frequency base

From the list, choose F1=4MHz, F2=400kHz, F3=40kHz, F4=4kHz, or F5=400Hz to set the base frequency.

Sample time

Enter the base sample time or a multiple of the base sample time. The sample time indicates the update rate of registration on the input (Duty Cycle)

Base address

Enter the base address of the board. This entry must correspond to the DIP switch setting on the board. For example, if the DIP switch setting is 300 (hexadecimal), enter `0x300`.

Diamond Quartz-MMxx

Diamond Quartz-MMxx block (not recommended)

Description

You can use this block to program the AMD9513A counter. The PWM, PWM & ARM, FM, FM & ARM, PWM Capture, and FM Capture blocks use this block in their underlying subsystems. The API for this block is not currently documented.

Displays and Logging Blocks No Longer Recommended for Use

These blocks are intended for low-level access to I/O ports. They are no longer recommended for use.

I/O Port Read

Read Intel 80x86 I/O port (not recommended)

I/O Port Write

Write Intel 80x86 I/O port (not recommended)

I/O Port Read

Read Intel 80x86 I/O port (not recommended)

Library

Simulink Real-Time Library of Drivers No Longer Recommended for Use

Description

Intel 80x86 and compatible processors have a special address space reserved for I/O devices.

Example

To access the special address space and communicate directly to a device, the Simulink Real-Time block library provides the **I/O Port Read** and **I/O Port Write** blocks. These blocks enable the transfer of data from and to the I/O ports (see also **I/O Port Write**).

- 1 Double click the **I/O Port Read** block.

The Block Parameters: **I/O Port Read** dialog box opens.

- 2 In the **I/O-Port address** box, enter the beginning address for each value this block reads.

For example, if you want to read a word (16 bits) starting at I/O port 0x300, followed by a byte (8 bits) at 0x302, enter

```
{'0x300', '0x302'}
```

- 3 In the **Data type** box, enter the type for each value this block reads. There is one type for each address you entered in the **I/O-Port address** box.

For example if you want to read a word and then a byte, enter

```
{'uint16', 'uint8'}
```

4 Click **OK**.

The number of outputs from the block changes to reflect the length of the I/O-Port address cell array.

Block Parameters

I/O-Port address (cell array)

This is the cell array containing the beginning I/O port addresses for the data you want to read. These addresses are specified in terms of hexadecimal strings.

Data type (cell array)

This is the cell array containing the types of data you want to read from I/O port. The **Data type** cell array has one value for each value in the **I/O-Port address** cell array.

The type `uint32` reads a double word (32 bits), `uint16` reads a word, and a `uint8` reads a byte.

Sample time

Enter the base sample time or a multiple of the base sample time (- 1 means sample time is inherited).

I/O Port Write

Write Intel 80x86 I/O port (not recommended)

Library

Simulink Real-Time Library of Drivers No Longer Recommended for Use

Description

Intel 80x86 and compatible processors have a special address space reserved for I/O devices.

Example

To access this special address space and communicate directly to a device, the Simulink Real-Time block library provides the **I/O Port Read** and **I/O Port Write** blocks. These blocks enable the transfer of data from and to the I/O ports (see **I/O Port Read**).

- 1 Double click the **I/O Port Write** block.

The **Block Parameters: I/O Port Write** dialog box opens.

- 2 Enter the parameters.

For example, if you want to write a double word (32 bits) starting at I/O port 0x300, followed by a word (16 bits) at 0x304, enter

```
{ '0x300', '0x304' }
```

- 3 Click **OK**.

The number of inputs to the block changes to reflect the length of the I/O-Port address cell array. The data type of the input signal reflects the type of value written to the I/O port. For example, an input signal of type `uint32` writes a double word, an `uint16` input signal writes a word, and an `uint8` input signal writes a byte.

Block Parameters

I/O-Port address (cell array)

This is the cell array containing the I/O port addresses for the data that you want read. These addresses are specified in terms of hexadecimal strings.

Sample time

Enter the base sample time or a multiple of the base sample time (- 1 means sample time is inherited).

GE Intelligent Platforms Drivers No Longer Recommended for Use

SBS Flex/104A PC/104 IP Carrier Board	Support for the SBS Flex/104A PC/104 IP Carrier board (not recommended)
SBS Flex-104A	Flex-104A block (not recommended)
SBS IP-16ADC	Support for the SBS IP-16ADC board (not recommended)
SBS IP-16ADC Analog Input (A/D)	IP-16ADC Analog Input block (not recommended)
SBS IP-16DAC	Support for the SBS IP-16DAC I/O board (not recommended)
SBS IP-16DAC Analog Output (D/A)	IP-16DAC Analog Output block (not recommended)
SBS IP-HiADC	Support for the SBS IP-HiADC board (not recommended)
SBS IP-HiADC Analog Input (A/D)	IP-HiADC Analog Input block (not recommended)
SBS IP-Synchro	Support for the SBS IP-Synchro board (not recommended)
SBS IP-Synchro/Resolver	IP-Synchro/Resolver block (not recommended)

SBS Flex/104A PC/104 IP Carrier Board

Support for the SBS Flex/104A PC/104 IP Carrier board (not recommended)

Board

SBS Flex/104A PC/104 IP Carrier Board

General Description

Each IP module must be physically plugged into an IP carrier board such as the Flex/104A. Models containing IP module blocks must also contain corresponding IP carrier blocks. If your model contains multiple carriers, be sure to use a unique ID for each carrier. The relationship “IP module A is plugged into carrier B” is expressed by selecting the same Carrier ID for both A and B.

The Flex/104A holds up to two IP modules.

The Simulink Real-Time block library supports this board with this driver block:

- SBS Flex-104A

Board Characteristics

Board name	Flex-104A PC/104 carrier board
Manufacturer	GE Intelligent Platforms (formerly SBS Technologies)
Bus type	PC/104
Access method	I/O Mapped
Multiple block instance support	No
Multiple board support	Yes

SBS Flex-104A

Flex-104A block (not recommended)

Library

Simulink Real-Time Library of Drivers No Longer Recommended for Use

Block Parameters

Carrier ID

Enter a number to uniquely identify this IP carrier board within the model. If your model contains multiple carriers, be sure to use a unique ID for each carrier.

Base address

Enter the base address of the board. For example, if the base address is 300 (hexadecimal), enter

0x300

This board permutes the expected pinout of the 50-pin I/O connector for each IP module as follows

Expected Pin	Actual Pin	Expected Pin	Actual Pin	Expected Pin	Actual Pin
1	1	18	35	35	20
2	3	19	37	36	22
3	5	20	39	37	24
4	7	21	41	38	26
5	9	22	43	39	28
6	11	23	45	40	30
7	13	24	47	41	32
8	15	25	49	42	34
9	17	26	2	43	36
10	19	27	4	44	38

Expected Pin	Actual Pin	Expected Pin	Actual Pin	Expected Pin	Actual Pin
11	21	28	6	45	40
12	23	29	8	46	42
13	25	30	10	47	44
14	27	31	12	48	46
15	29	32	14	49	48
16	31	33	16	50	50
17	33	34	18		

SBS IP-16ADC

Support for the SBS IP-16ADC board (not recommended)

Board

SBS IP-16ADC

General Description

The IP-16ADC I/O board has 16 single or 8 differential analog input (A/D) channels (16-bit) with a combined throughput of 100 kHz.

The Simulink Real-Time block library supports this board with this driver block:

- SBS IP-16ADC Analog Input (A/D)

Note: To operate the IP-16ADC I/O board, connect an external ± 15 volt power supply to the I/O interface of the board. Failure to do so prevents the conversion.

Board Characteristics

Board name	IP-16ADC
Manufacturer	GE Intelligent Platforms (formerly SBS Technologies)
Bus type	N/A
Access method	I/O Mapped
Multiple block instance support	Yes
Multiple board support	Yes

SBS IP-16ADC Analog Input (A/D)

IP-16ADC Analog Input block (not recommended)

Library

Simulink Real-Time Library of Drivers No Longer Recommended for Use

Scaling Input to Output

Hardware Input	Block Output Data Type	Scaling
Volts	double	1

Block Parameters

Carrier ID

Enter the Carrier ID of the IP carrier board into which the IP module is plugged.

To use an IP module, it must be physically plugged into an IP carrier board and the model must contain a block representing this carrier board. Each carrier block has a **Carrier ID** parameter, which must be set to a number not shared by other carrier board block in the model.

Carrier slot

Select the slot on the carrier board into which the IP-16ADC module is plugged. Different carrier boards can have different slot capacities.

Channel vector

Enter a vector of numbers between 1 and 16. The channel numbers can occur in arbitrary order. For example, to use the first and third analog output (A/D) channels, enter

[1, 3]

Number the channels beginning with 1 even if this board manufacturer starts numbering the channels with 0.

Range vector

Enter a range code for each of the channels in the channel vector. The range vector must be the same length as the channel vector. This board allows the range of each channel to be different.

The following table is a list of the ranges for this driver and the corresponding range codes.

Range Code	Input Range (V)
-10	-10 to +10
-5	-5 to +5
5	0 to 5
10	0 to 10

Range codes -10 and -5 specify differential channels, which each use two pins on the I/O cable. Range codes 10 and 5 specify single-ended channels, which each use only one pin. Certain combinations of channel numbers and range codes can refer to conflicting physical I/O pins and will cause an error of the form "Bipolar channel X and unipolar channel Y use the same I/O pins". Consult the section "I/O Pin Wiring" in the IP-16ADC User's Manual as you select the channel and range vectors to avoid this.

Sample time

Enter the base sample time or a multiple of the base sample time (- 1 means sample time is inherited).

SBS IP-16DAC

Support for the SBS IP-16DAC I/O board (not recommended)

Board

SBS IP-16DAC

General Description

The IP-16DAC I/O board has 3 independent precalibrated analog output (D/A) channels (16-bit).

The Simulink Real-Time block library supports this board with this driver block:

- SBS IP-16DAC Analog Output (D/A)

Board Characteristics

Board name	IP-16DAC
Manufacturer	GE Intelligent Platforms (formerly SBS Technologies)
Bus type	N/A
Access method	I/O Mapped
Multiple block instance support	Yes
Multiple board support	Yes

SBS IP-16DAC Analog Output (D/A)

IP-16DAC Analog Output block (not recommended)

Library

Simulink Real-Time Library of Drivers No Longer Recommended for Use

Scaling Input to Output

Hardware Output	Block Input Data Type	Scaling
Volts	double	1

Block Parameters

Carrier ID

Enter the Carrier ID of the IP carrier board into which the IP module is plugged.

To use an IP module, it must be physically plugged into an IP carrier board and the model must contain a block representing this carrier board. Each carrier block has a **Carrier ID** parameter, which must be set to a number not shared by another carrier board block in the model.

Carrier slot

Select the slot on the carrier board into which the IP-16DAC module is plugged. Different carrier boards can have different slot capacities.

Channel vector

Enter a vector of numbers between 1 and 3. The channel numbers can occur in arbitrary order. For example, to use the first and second analog output (D/A) channels, enter

[1,2]

Channel numbers 1, 2, and 3 correspond to DAC A, DAC B, and DAC C respectively.

Range vector

Enter a range code for each of the channels in the channel vector. The range vector must be the same length as the channel vector. This board allows the range of each channel to be different.

The following table is a list of the ranges for this driver and the corresponding range codes.

Input Range (V)	Range Code
-10 to +10	-10
-5 to +5	-5
0 to +5	5
0 to +10	10

For example, if the first channel is -10 to +10 volts and the second channel is 0 to +5 volts, enter

`[-10,5]`

The range settings must correspond to the jumper settings on the board for DAC A, DAC B, and DAC C.

Sample time

Enter the base sample time or a multiple of the base sample time (- 1 means sample time is inherited).

SBS IP-HiADC

Support for the SBS IP-HiADC board (not recommended)

Board

SBS IP-HiADC

General Description

The IP-HiADC I/O board has 16 analog input (A/D) channels (12-bit).

The Simulink Real-Time block library supports this board with this driver block:

- SBS IP-HiADC Analog Input (A/D)

Board Characteristics

Board name	IP-HiADC
Manufacturer	GE Intelligent Platforms (formerly SBS Technologies)
Bus type	N/A
Access method	I/O Mapped
Multiple block instance support	Yes
Multiple board support	Yes

SBS IP-HiADC Analog Input (A/D)

IP-HiADC Analog Input block (not recommended)

Library

Simulink Real-Time Library of Drivers No Longer Recommended for Use

Scaling Input to Output

Hardware Input	Block Output Data Type	Scaling
Volts	double	1

Block Parameters

Carrier ID

Enter the Carrier ID of the IP carrier board into which the IP module is plugged.

To use an IP module, it must be physically plugged into an IP carrier board and the model must contain a block representing this carrier board. Each carrier block has a **Carrier ID** parameter, which must be set to a number not shared by another carrier board block in the model.

Carrier slot

Select the slot on the carrier board into which the IP-HiADC module is plugged. Different carrier boards can have different slot capacities.

Channel vector

Enter a vector of numbers between 1 and 16. The channel numbers can occur in arbitrary order. For example, to use the first and third analog output (A/D) channels, enter

[1, 3]

Number the channels beginning with 1 even if this board manufacturer starts numbering the channels with 0.

Range

Select either -5V to 5V or -10V to 10V. This applies to all channels.

Sample time

Enter the base sample time or a multiple of the base sample time (- 1 means sample time is inherited).

SBS IP-Synchro

Support for the SBS IP-Synchro board (not recommended)

Board

SBS IP-Synchro

General Description

IP-Synchro provides two channels of position measurement using synchro, resolver, LVDT, or Inductosyn® transducers.

The Simulink Real-Time block library supports this board with this driver block:

- SBS IP-Synchro

Board Characteristics

Board name	IP-Synchro
Manufacturer	GE Intelligent Platforms (formerly SBS Technologies)
Bus type	N/A
Access method	I/O Mapped
Multiple block instance support	No
Multiple board support	Yes

SBS IP-Synchro/Resolver

IP-Synchro/Resolver block (not recommended)

Library

Simulink Real-Time Library of Drivers No Longer Recommended for Use

Scaling Input to Output

Hardware Output	Block Output Data Type	Scaling
Synchro or Resolver	double	angle in radians

Block Parameters

Carrier ID

Enter the Carrier ID of the IP carrier board into which the IP-Synchro module is plugged.

To use an IP module, it must be physically plugged into an IP carrier board and the model must contain a block representing this carrier board. Each carrier block has a **Carrier ID** parameter, which must be set to a number not shared by another carrier board block in the model.

Carrier slot

Select the slot on the carrier board into which the IP-Synchro module is plugged. Different carrier boards can have different slot capacities.

Channel vector

Enter a vector with one or two elements to select the Synchro/Resolver input channels you use with this block. 1 represents channel A and 2 represents channel B. This driver allows the selection of inputs in either order.

For example to use channels A and B in that order, enter

[1,2]

Precision vector

This must be a scalar or a vector the same length as the channel vector. For each input channel it specifies a precision of either 10, 12, 14, or 16 bits. If the **Automatic precision** parameter is set, then the selected precision for each channel will be used for the entire run. Otherwise it merely specifies the initial precision.

Automatic precision

Select this check box to have the IP-Synchro automatically change its precision (resolution) to track the input velocity.

Output format

This option selects the output status format.

- **position** — Output position only
- **position and status** — Output position and status

Sample time

Enter the base sample time or a multiple of the base sample time (- 1 means sample time is inherited).

HUMUSOFT Drivers No Longer Recommended for Use

Humusoft AD 512

HUMUSOFT AD 512 board (not recommended)

Humusoft AD 512 Analog Input (A/D)

HUMUSOFT AD 512 Analog Input block (not recommended)

Humusoft AD 512 Analog Output (D/A)

HUMUSOFT AD 512 Analog Output block (not recommended)

Humusoft AD 512 Digital Input

HUMUSOFT AD 512 Digital Input block (not recommended)

Humusoft AD 512 Digital Output

HUMUSOFT AD 512 Digital Output block (not recommended)

Humusoft AD 512

HUMUSOFT AD 512 board (not recommended)

Board

HUMUSOFT AD 512

General Description

The AD 512 is an I/O board with 8 single analog input (A/D) channels (12-bit) with a maximum sample rate of 100 kHz, 2 analog output (D/A) channels (12-bit), 8 digital inputs, and 8 digital outputs.

The Simulink Real-Time block library supports this board with these driver blocks:

- Humusoft AD 512 Analog Input (A/D)
- Humusoft AD 512 Analog Output (D/A)
- Humusoft AD 512 Digital Input
- Humusoft AD 512 Digital Output

Board Characteristics

Board name	AD 512
Manufacturer	HUMUSOFT
Bus type	ISA
Access method	I/O mapped
Multiple block instance support	Digital Input: Yes, Others: No
Multiple board support	Yes

Humusoft AD 512 Analog Input (A/D)

HUMUSOFT AD 512 Analog Input block (not recommended)

Library

Simulink Real-Time Library of Drivers No Longer Recommended for Use

Scaling Input to Output

Hardware Input	Block Output Data Type	Scaling
Volts	Double	1

Block Parameters

Channel vector

Enter numbers between 1 and 8. This driver allows the selection of individual channels in arbitrary order. The number of elements defines the number of A/D channels used.

For example, to use the first, second, and fifth channels, enter

[1,2,5]

Number the channels beginning with 1 even if this board manufacturer starts numbering the channels with 0.

Range vector

Enter a range code for each of the channels entered in the channel vector. The range vector must be the same length as the channel vector. This driver allows a different range for each channel.

The following table is a list of the ranges for this driver and the corresponding range codes.

Input Range (V)	Range Code
-10 to +10	-10

Input Range (V)	Range Code
-5 to +5	-5
0 to +10	10
0 to +5	5

For example, if the first channel is -10 to +10 volts and the second and fifth channels are 0 to +5 volts, enter

[-10,5,5]

Sample time

Enter the base sample time or a multiple of the base sample time (- 1 means sample time is inherited).

Base address

Enter the base address of the board. This entry must correspond to the DIP switch setting on the board. For example, if the DIP switch setting is 300 (hexadecimal), enter 0x300.

Humusoft AD 512 Analog Output (D/A)

HUMUSOFT AD 512 Analog Output block (not recommended)

Library

Simulink Real-Time Library of Drivers No Longer Recommended for Use

Scaling Input to Output

Hardware Output	Block Input Data Type	Scaling
Volts	Double	1

Block Parameters

Channel vector

This parameter is a combined channel vector and range vector. The number of elements defines the number of D/A channels used.

Enter a range code for each of the channels used. This driver allows a different range for each channel with a maximum of two channels.

The following table is a list of the ranges for this driver and the corresponding range codes.

Input Range (V)	Range Code
-10 to +10	-10
-5 to +5	-5
0 to +10	10
0 to +5	5

For example, if the first channel is -10 to +10 volts and the second channel is 0 to +5 volts, enter

[-10,5]

Sample time

Enter the base sample time or a multiple of the base sample time (-1 means sample time is inherited).

Base address

Enter the base address of the board. This entry must correspond to the DIP switch setting on the board. For example, if the DIP switch setting is 300 (hexadecimal), enter 0x300.

Humusoft AD 512 Digital Input

HUMUSOFT AD 512 Digital Input block (not recommended)

Library

Simulink Real-Time Library of Drivers No Longer Recommended for Use

Scaling Input to Output

Hardware Input	Block Output Data Type	Scaling
TTL	Double	TTL low = 0.0 TTL high = 1.0

Channel vector

Enter a numbers between 1 and 8. This driver allows the selection of individual digital line numbers in arbitrary order. The number of elements defines the number of digital input lines used.

For example, to use the first, second, and fifth digital input lines, enter

[1,2,5]

Number the lines beginning with 1, even if this board manufacturer starts numbering the lines with 0.

Sample time

Enter the base sample time or a multiple of the base sample time (-1 means sample time is inherited).

Base address

Enter the base address of the board. This entry must correspond to the DIP switch setting on the board. For example, if the DIP switch setting is 300 (hexadecimal), enter 0x300.

Humusoft AD 512 Digital Output

HUMUSOFT AD 512 Digital Output block (not recommended)

Library

Simulink Real-Time Library of Drivers No Longer Recommended for Use

Scaling Input to Output

Hardware Output	Block Input Data Type	Scaling
TTL	Double	< 0.5 = TTL low ≥ 0.5 = TTL high

Channel vector

Enter numbers between 1 and 8. This driver allows the selection of individual digital line numbers in arbitrary order. The number of elements defines the number of digital output lines used.

For example, to use the first, second, and fifth digital output lines, enter

[1,2,5]

Number the lines beginning with 1, even if this board manufacturer starts numbering the lines with 0.

Sample time

Enter the base sample time or a multiple of the base sample time (-1 means sample time is inherited).

Base address

Enter the base address of the board. This entry must correspond to the DIP switch setting on the board. For example, if the DIP switch setting is 300 (hexadecimal), enter 0x300.

J1939 Drivers No Longer Recommended for Use

The following blocks represent drivers that are no longer in use. Update to the current drivers.

J1939 Database Setup

J1939 Database Setup (not recommended)

J1939 Message Triggering

J1939 Message Triggering (not recommended)

J1939 Pack

J1939 Pack (not recommended)

J1939 Receive

J1939 Receive (not recommended)

J1939 Transmit

J1939 Transmit (not recommended)

J1939 Unpack

J1939 Unpack (not recommended)

J1939 Database Setup

J1939 Database Setup (not recommended)

Library

Simulink Real-Time Library of Drivers No Longer Recommended for Use

Description

The J1939 Database Setup block identifies the user-supplied database for the J1939 block set. Use one block per model.

Block Parameters

J1939 database file

Specify the J1939 database location and file name, for example 'J1939.dbc'.

This file defines the J1939 message set and is in a format defined by Vector Informatik GmbH.

Note: You must supply the database file. The Simulink Real-Time software does not supply this file.

J1939 Message Triggering

J1939 Message Triggering (not recommended)

Library

Simulink Real-Time Library of Drivers No Longer Recommended for Use

Description

The J1939 Message Triggering block manages the multiple trigger conditions possible for triggering the transmission of a J1939 message.

Block Inputs

This block has the following input ports:

Enable

Receives the signal that indicates when the block is enabled.

Request

Receives the signal that indicates a request to send has been received.

Active

Indicates when a message is in the active state.

Change

Receives the signal whose change triggers the sending of a message.

Block Outputs

This block has the following output ports:

Message Enable

Signal of type double that is set to 1 when the message should be packed. It is typically connected to the input port of a **J1939 Pack** block.

Block Parameters

Repetition

From the list, select:

- On Request Only
- Engine Speed Based
- Time Based

Repeat on Interval

Select this check box to repeat at the interval specified in the **Repetition Interval** parameter.

Repetition Interval

Specify the enabled repetition interval in milliseconds. The repetition interval should be an integer multiple of the model update rate.

Change Interval on External Active Signal

Select this check box to enable the message to repeat at the interval specified in **Interval when Active** when the external signal is active.

Interval when Active

Enter the active repetition interval in milliseconds. The interval should be an integer multiple of the model update rate.

Send on Change

Select this check box to send the message when the input signal that is wired to the change port changes by the value in the **Change threshold** parameter.

Change Threshold

Enter the threshold for message transmission to any change (**Any**) or a change greater than 10% (**10%**).

Minimum Change Interval

Enter a minimum change interval.

J1939 Pack

J1939 Pack (not recommended)

Library

Simulink Real-Time Library of Drivers No Longer Recommended for Use

Description

The J1939 Pack block assembles a message suitable for sending over the CAN network.

Block Inputs

The block input signal indicates when the message should be sent. You can connect this signal to a J1939 Message Triggering block or to a user selected block. When the signal is 1, the block packs a new message from the current signal input values.

The other input ports are dynamic and depend on the value of the **PGN** value of the message. The block inputs are of type double.

Block Outputs

The single output is a vector of unsigned bytes of variable length. This output is typically connected to the input of the J1939 Transmit block.

Block Parameters

PGN

Select the message that this block unpacks. From the list, select a parameter group number (PGN). The block automatically creates input ports according to the number and type of suspect parameter numbers (SPNs) that correspond to the PGN.

Priority

Enter the three priority bits of this message. Enter a message priority from 0 to 7, with 0 being the highest and 7 being the lowest.

Destination Address

Enter the destination address for destination-specific messages. See the SAE J1939-21 for information.

J1939 Receive

J1939 Receive (not recommended)

Library

Simulink Real-Time Library of Drivers No Longer Recommended for Use

Description

The J1939 Receive block receives the PGNs.

Block Inputs

Connect the J1939 Receive block directly to the output of a CAN FIFO Read block. The input signal is a matrix of size $m \times 6$, where m is the FIFO read depth defined in the FIFO Read block dialog box. Each row with its six elements contains the information defining a CAN message:

Port
Identifier
Event type
Data frame size
Timestamp
Data

See one of the FIFO Read blocks (for example, `Softing CAN-AC2-PCI with Philips SJA1000 FIFO Read`) for a detailed description of these elements.

Block Outputs

The number of parameter group numbers (PGNs) in the **PGN list** parameter determines the number of block outputs. The block creates and labels an output port for each PGN in the list. Each output signal is a vector of unsigned bytes with a length of 16. The bytes are defined as follows:

Bit	Description
y[1]	Protocol data unit format (PDU format or PF)
y[2]	Group extension if PF is greater than 240, else destination address (DA)
y[3]	Source address
y[4]	Timestamp[0]
y[5]	Timestamp[1]
y[6]	Timestamp[2]
y[7]	Timestamp[3]
y[8]	Data byte 1
y[9]	Data byte 2
y[10]	Data byte 3
y[11]	Data byte 4
y[12]	Data byte 5
y[13]	Data byte 6
y[14]	Data byte 7
y[15]	Data byte 8

Block Parameters

CAN Port

Select the filter criterion for the CAN port. From the list, select **Any**, **1**, or **2**.

PGN List

Enter the acceptance filter criterion for the parameter group number (PGN). Enter a list of PGNs that you want to receive. You can provide a set of PGNs as a row vector.

When the CAN FIFO blocks receives the data that corresponds to these PGNs, they filter these messages and send them to the J1939 **Unpack** block.

CA Address

Enter the filter acceptance criterion for the specified controller application ID. Only messages whose destination addresses match the current controller application address or the global address will be routed to a PGN output.

J1939 Transmit

J1939 Transmit (not recommended)

Library

Simulink Real-Time Library of Drivers No Longer Recommended for Use

Description

The J1939 Receive block sends the PGNs.

Block Inputs

The J1939 Transmit block inputs are typically connected directly to one or more **J1939 Pack** blocks. The output of the J1939 Transmit block is typically connected to the input of a CAN FIFO Send block. The J1939 Transmit block input is of type unsigned 8-bit integer. The bytes are:

Priority

Data Page and Reserved Bits

PDU Format

PDU Specific

Destination Address

Data Frame Size [0]

Data Frame Size [1]

New message Flag

Block Outputs

The J1939 Transmit block has a single output port of type double. The output signal is a matrix of size $n \times 6$, where n is the value in the **Number of input messages** parameter. At this port, you must provide information required to construct valid CAN messages to be written into the transmit FIFO. For each CAN message, you must pass six elements. See the documentation for the FIFO Write block (such as **Softing CAN-AC2-PCI** with **Philips SJA1000 FIFO Write**) for a detailed description of these elements.

Port

The value can be either 1 (port 1) or 2 (port 2) and defines the port the CAN message is sent from.

Identifier

Identifier of the CAN message to be sent. If it is a standard CAN message, the valid range is 0 to 2047. If the CAN message is extended, the range is 0 to $2^{29}-1$. J1939 identifiers are extended. J1939 messages can share the physical network with another protocol using standard identifiers.

Identifier type

The value can be either 0 (standard identifier range) or 1 (extended identifier range) and defines the identifier type of the outgoing CAN message. J1939 identifiers are extended.

Data frame size

The value can be in the range of 0 to 8 and defines the data frame size of the outgoing CAN message in bytes. The CAN messages generated by J1939 are usually 8 bytes in length. The exception is the request message, which has a length of 3 bytes.

Data

This is the data for the data frame itself and is defined as a double value (8 bytes). The CAN packing block is used to construct the data as a double value.

Block Parameters

Port (1 or 2)

Enter the port from which to send the message. Enter a value of 1 (port 1) or 2 (port 2) to define the port the CAN message is sent from.

Number of input messages

Specify the number of inputs to this block. One input for each unique PGN and destination address is required.

Source Address

Specify the source address for the messages of the current node.

J1939 Unpack

J1939 Unpack (not recommended)

Library

Simulink Real-Time Library of Drivers No Longer Recommended for Use

Description

The J1939 Unpack block disassembles a message suitable for sending over the CAN network.

Block Inputs

Connect the J1939 Receive block directly to the output of a J1939 Unpack block. The input signal is a vector of unsigned bytes with a length of 16. The bytes are defined as follows:

Bit	Description
y[0]	Reserved bit and data page bit
y[1]	Protocol data unit format (PDU format or PF)
y[2]	Group extension if PF is greater than 240, else destination address (DA)
y[3]	Source address
y[4]	Timestamp[0]
y[5]	Timestamp[1]
y[6]	Timestamp[2]
y[7]	Timestamp[3]
y[8]	Data byte 1
y[9]	Data byte 2
y[10]	Data byte 1
y[11]	Data byte 2

Bit	Description
y[12]	Data byte 3
y[13]	Data byte 4
y[14]	Data byte 5
y[15]	Data byte 6

Block Outputs

The **PGN** parameter determines the number of block outputs. The number and definition for each parameter is dynamic. For each suspect parameter number (SPN), the block creates an output of type double.

Block Parameters

PGN

Set the message that this block unpacks. From the list, select a PGN. The driver automatically creates input ports according to the number and type of SPNs that correspond to the PGN.

Source

Enter the acceptance filter criterion for the source address.

Destination

Enter the filter acceptance criterion for the specified destination. From the list, select:

- global and specific
- global only
- specific only

Keithley Drivers No Longer Recommended for Use

Keithley DAS-1800HR	Keithley DAS-1800HR board (not recommended)
Keithley DAS-1800HR Analog Input (A/D)	DAS-1800HR Analog Input block (not recommended)
Keithley DAS-1800HR Digital Input	DAS-1800HR Digital Input block (not recommended)
Keithley DAS-1800HR Digital Output	DAS-1800HR Digital Output block (not recommended)
Keithley KCPI-1801HC	Keithley KCPI-1801HC board (not recommended)
Keithley KPCI-1801HC Analog Input (A/D)	KPCI-1801HC Analog Input block (not recommended)
Keithley KPCI-1801HC Analog Output (D/A)	KPCI-1801HC Analog Output block (not recommended)
Keithley KPCI-1801HC Digital Input	KPCI-1801HC Digital Input block (not recommended)
Keithley KPCI-1801HC Digital Output	KPCI-1801HC Digital Output block (not recommended)
Keithley KPCI-1802HC	Keithley KPCI-1802HC board (not recommended)
Keithley KPCI-1802HC Analog Input (A/D)	KPCI-1802HC Analog Input block (not recommended)
Keithley KPCI-1802HC Analog Output (D/A)	KPCI-1802HC Analog Output block (not recommended)

Keithley KPCI-1802HC Digital Input

KPCI-1802HC Digital Input block (not recommended)

Keithley KPCI-1802HC Digital Output

KPCI-1802HC Digital Output block (not recommended)

Keithley DAS-1800HR

Keithley DAS-1800HR board (not recommended)

Board

Keithley DAS-1800HR

General Description

The DAS-1800HR is an I/O board with 16 single or 8 differential analog input (A/D) channels (16-bit) with a maximum sample rate of 100 kHz, 4 digital input lines and 4 digital output lines.

The Simulink Real-Time block library supports this board with these driver blocks:

- Keithley DAS-1800HR Analog Input (A/D)
- Keithley DAS-1800HR Digital Input
- Keithley DAS-1800HR Digital Output

Board Characteristics

Board name	DAS-1800HR
Manufacturer	Keithley
Bus type	ISA
Access method	I/O mapped
Multiple block instance support	No
Multiple board support	Yes

Keithley DAS-1800HR Analog Input (A/D)

DAS-1800HR Analog Input block (not recommended)

Library

Simulink Real-Time Library of Drivers No Longer Recommended for Use

Scaling Input to Output

Hardware Input	Block Output Data Type	Scaling
Volts	Double	1

Block Parameters

Channel vector

If you select 16 channels (**Input coupling** parameter set to **Single-ended channels** or **Single-ended common mode**) enter numbers between 1 and 16 to select the number of individual channels used. If you select eight channels (**Input coupling** parameter set to **Differential**) enter numbers between 1 and 8 to select the A/D channels used. This driver allows the selection of individual A/D channels in arbitrary order. The number of elements defines the number of A/D channels used.

For example, to use the first, second and fifth channels, enter

```
[1,2,5]
```

Number the channels beginning with 1 even if this board manufacturer starts numbering the channels with 0.

Gain vector (1,2,4,8)

Enter 1, 2, 4, or 8 for each of the channels in the channel vector to choose the gain code of that channel. The gain vector must be the same length as the channel vector. This driver allows the gain of each channel to be different.

Notice that by increasing the gain code the voltage range is decreased. The gain divides the input voltage range.

For example, if the first channel has a gain code of 1 (10 volt range) and the second and fifth channels have a gain code of 2 (5 volt range), enter

[1,2,2]

Range vector

From the list, choose either **Bipolar** or **Unipolar**.

The range setting defines if the board is working in bipolar or unipolar input mode. This setting is the same for all of the selected channels.

The following table is a list of the ranges for this driver given the gain entered and the range chosen.

Gain	Bipolar Range (V)	Unipolar Range (V)
1	-10 to +10	0 to 10
2	-5 to + 5	0 to +5
4	-2.5 to 2.5	0 to 2.5
8	-1.25 to +1.25	0 to 1.25

Input coupling

From the list, select one from the following list of input modes:

- Differential (8 channels)
- Single-ended (16 channels)
- Single-ended common mode (16 channels)

This choice must correspond to the MUX-switch setting on the board.

Common-mode is similar to single-ended mode but the negative wire of the source to be measured is connected to input AI-SENSE instead of LIGND.

Sample time

Enter the base sample time or a multiple of the base sample time (- 1 means sample time is inherited).

Base address

Enter the base address of the board. This entry must correspond to the DIP switch setting on the board. For example, if the DIP switch setting is 300 (hexadecimal), enter 0x300.

Keithley DAS-1800HR Digital Input

DAS-1800HR Digital Input block (not recommended)

Library

Simulink Real-Time Library of Drivers No Longer Recommended for Use

Scaling Input to Output

Hardware Input	Block Output Data Type	Scaling
TTL	Double	TTL low = 0.0 TTL high = 1.0

Block Parameters

Number of channels

Enter a number between 1 and 8 to select the number of digital input lines used with this port.

Sample time

Enter the base sample time or a multiple of the base sample time (-1 means sample time is inherited).

Base address

Enter the base address of the board. This entry must correspond to the DIP switch setting on the board. For example, if the DIP switch setting is 300 (hexadecimal), enter 0x300.

Keithley DAS-1800HR Digital Output

DAS-1800HR Digital Output block (not recommended)

Library

Simulink Real-Time Library of Drivers No Longer Recommended for Use

Scaling Input to Output

Hardware Output	Block Input Data Type	Scaling
TTL	Double	$< 0.5 = \text{TTL low}$ $\geq 0.5 = \text{TTL high}$

Block Parameters

Number of channels

Enter a number between 1 and 4 to select the number of digital output lines used with this port.

Sample time

Enter the base sample time or a multiple of the base sample time (-1 means sample time is inherited).

Base address

Enter the base address of the board. This entry must correspond to the DIP switch setting on the board. For example, if the DIP switch setting is 300 (hexadecimal), enter 0x300.

Keithley KCPI-1801HC

Keithley KCPI-1801HC board (not recommended)

Board

Keithley KCPI-1801HC

General Description

The KCPI-1801 is an I/O board with 64 single or 32 differential analog input (A/D) channels (12-bit) with a maximum sample rate of 333 kHz, 2 analog output (D/A) channels (12-bit), and 4 digital input and output lines.

The Simulink Real-Time block library supports this board with these driver blocks:

- Keithley KPCI-1801HC Analog Input (A/D)
- Keithley KPCI-1801HC Analog Output (D/A)
- Keithley KPCI-1801HC Digital Input
- Keithley KPCI-1801HC Digital Output

The Simulink Real-Time software does not support the counter/timers on this board.

Board Characteristics

Board name	KCPI-1801HC
Manufacturer	Keithley Instruments
Bus type	PCI
Access method	Memory mapped
Multiple block instance support	A/D: No, D/A: Yes, Digital I/O: Yes
Multiple board support	Yes

Keithley KPCI-1801HC Analog Input (A/D)

KPCI-1801HC Analog Input block (not recommended)

Library

Simulink Real-Time Library of Drivers No Longer Recommended for Use

Scaling Input to Output

Hardware Input	Block Output Data Type	Scaling
Volts	Double	1

Block Parameters

Channel vector

Enter numbers between 1 and 64. This driver allows you to enter channel numbers in arbitrary order.

For example, to use the first, second, and fifth channels, enter

[1,2,5]

Number the channels beginning with 1 even if this board manufacturer starts numbering the channels with 0.

Range vector

Enter a range code for each of the channels in the channel vector. The range vector must be the same length as the channel vector. This driver allows each channel to be different.

The following table is a list of the ranges for this driver and the corresponding range codes.

Input Range (V)	Range Code
-5 to +5	-5

Input Range (V)	Range Code
-1 to +1	-1
-0.1 to +0.1	-0.1
-0.02 to +0.02	-0.02
0 to +5	5
0 to +1	1
0 to +0.1	0.1
0 to +0.02	0.02

For example, if the first channel is -5 to +5 volts and the second and fifth channels are 0 to +1 volts, enter

`[-5, 1, 1]`

Input coupling vector

Enter a coupling code for each of the channels in the channel vector. The coupling vector must be the same length as the channel vector. This driver allows a different coupling for each channel.

The following table is a list of the couplings for this driver and the corresponding coupling codes.

Coupling	Coupling Code	Description
single- ended	0	Analog input line connected to the positive input. Analog input ground (IGND) internally connected to the negative input.
differential	1	First analog input line connected to the positive input of the PGIA. Second analog input line connected to the negative input of the PGIA. See the board manual.

For example, if the first and second channels are single input and the fifth channel is a differential input, enter

`[0, 0, 1]`

The driver selects a second differential input 32 channels higher than the first channel. In the example above, the driver would select the 37th channel as a differential input with the fifth channel.

Sample time

Enter the base sample time or a multiple of the base sample time (- 1 means sample time is inherited).

PCI slot (-1:autosearch)

If only one board of this type is in the target computer, enter - 1 to locate the board.

If two or more boards of this type are in the target computer, enter the bus number and the PCI slot number of the board associated with this driver block. Use the format **[BusNumber,SlotNumber]**.

To determine the bus number and the PCI slot number, type:

```
tg = slrt;  
getPCIInfo(tg, 'installed')
```

Keithley KPCI-1801HC Analog Output (D/A)

KPCI-1801HC Analog Output block (not recommended)

Library

Simulink Real-Time Library of Drivers No Longer Recommended for Use

Note

The analog output range of this board is set -10 to +10 volts.

Scaling Input to Output

Hardware Output	Block Input Data Type	Scaling
Volts	Double	1

Block Parameters

Channel vector

Enter numbers 1 or 2. This driver allows the selection of individual D/A channels in arbitrary order. The number of elements defines the number of D/A channels used. For example, to use both of the analog output channels, enter

[1,2]

Number the channels beginning with 1 even if this board manufacturer starts numbering the channels with 0.

Reset vector

The reset vector controls the behavior of the channel at model termination. Enter a scalar or a vector that is the same length as the channel vector. If you specify a scalar value, that setting is replicated over the channel vector. If you specify a value of 1, the corresponding channel is reset to the value specified in the initial value vector.

If you specify a value of 0, the channel remains at the last value attained while the model was running.

Initial value vector

The initial value vector contains the initial voltage values for the output channels. Enter a scalar or a vector that is the same length as the channel vector. If you specify a scalar value, that value is replicated as the initial value over the channel vector. The channels are set to the initial values between the time the model is downloaded and the time it is started.

Sample time

Enter the base sample time or a multiple of the base sample time (- 1 means sample time is inherited).

PCI slot (-1:autosearch)

If only one board of this type is in the target computer, enter - 1 to locate the board.

If two or more boards of this type are in the target computer, enter the bus number and the PCI slot number of the board associated with this driver block. Use the format **[BusNumber, SlotNumber]**.

To determine the bus number and the PCI slot number, type:

```
tg = slrt;  
getPCIInfo(tg, 'installed')
```

Keithley KPCI-1801HC Digital Input

KPCI-1801HC Digital Input block (not recommended)

Library

Simulink Real-Time Library of Drivers No Longer Recommended for Use

Scaling Input to Output

Hardware Input	Block Output Data Type	Scaling
TTL	Double	TTL low = 0.0 TTL high = 1.0

Block Parameters

Channel vector

Enter numbers between 1 and 4 to select the digital input lines used with this port. This driver allows the selection of individual digital input lines in arbitrary order. The number of elements defines the number of digital lines used.

For example, to use all of the digital inputs for one port, enter

```
[1,2,3,4]
```

Number the lines beginning with 1 even if this board manufacturer starts numbering the lines with 0.

Sample time

Enter the base sample time or a multiple of the base sample time (-1 means sample time is inherited).

PCI slot (-1:autosearch)

If only one board of this type is in the target computer, enter -1 to locate the board.

If two or more boards of this type are in the target computer, enter the bus number and the PCI slot number of the board associated with this driver block. Use the format **[BusNumber,SlotNumber]**.

To determine the bus number and the PCI slot number, type:

```
tg = slrt;  
getPCIInfo(tg, 'installed')
```

Keithley KPCI-1801HC Digital Output

KPCI-1801HC Digital Output block (not recommended)

Library

Simulink Real-Time Library of Drivers No Longer Recommended for Use

Scaling Input to Output

Hardware Output	Block Input Data Type	Scaling
TTL	Double	$< 0.5 = \text{TTL low}$ $\geq 0.5 = \text{TTL high}$

Block Parameters

Channel vector

Enter numbers between 1 and 8 to select the digital output lines used with this port. This driver allows the selection of individual digital output lines in arbitrary order. The number of elements defines the number of digital lines used.

For example, to use all of the digital outputs for one port, enter

```
[1,2,3,4,5,6,7,8]
```

Number the lines beginning with 1 even if this board manufacturer starts numbering the lines with 0.

Reset vector

The reset vector controls the behavior of the channel at model termination. Enter a scalar or a vector that is the same length as the channel vector. If you specify a scalar value, that setting is replicated over the channel vector. If you specify a value of 1, the corresponding channel is reset to the value specified in the initial value vector. If you specify a value of 0, the channel remains at the last value attained while the model was running.

Initial value vector

The initial value vector contains the initial values (0 or 1) of the output channels. Enter a scalar or a vector that is the same length as the channel vector. If you enter a scalar, that value is replicated as the initial value over the channel vector. The channels are set to these initial values between the time the model is downloaded and the time it is started.

Sample time

Enter the base sample time or a multiple of the base sample time (- 1 means sample time is inherited).

PCI slot (-1:autosearch)

If only one board of this type is in the target computer, enter - 1 to locate the board.

If two or more boards of this type are in the target computer, enter the bus number and the PCI slot number of the board associated with this driver block. Use the format **[BusNumber,SlotNumber]**.

To determine the bus number and the PCI slot number, type:

```
tg = slrt;  
getPCIInfo(tg, 'installed')
```

Keithley KPCI-1802HC

Keithley KPCI-1802HC board (not recommended)

Board

Keithley KPCI-1802HC

General Description

The KPCI-1802 is an I/O board with 64 single or 32 differential analog input (A/D) channels (12-bit) with a maximum sample rate of 333 kHz, 2 analog output (D/A) channels (12-bit), and 4 digital input and output lines.

The Simulink Real-Time block library supports this board with these driver blocks:

- Keithley KPCI-1802HC Analog Input (A/D)
- Keithley KPCI-1802HC Analog Output (D/A)
- Keithley KPCI-1802HC Digital Input
- Keithley KPCI-1802HC Digital Output

The Simulink Real-Time software does not support the counter/timers on this board.

Board Characteristics

Board name	KPCI-1802HC
Manufacturer	Keithley Instruments
Bus type	PCI
Access method	Memory mapped
Multiple block instance support	A/D: No, D/A: Yes, Digital I/O: Yes
Multiple board support	Yes

Keithley KPCI-1802HC Analog Input (A/D)

KPCI-1802HC Analog Input block (not recommended)

Library

Simulink Real-Time Library of Drivers No Longer Recommended for Use

Scaling Input to Output

Hardware Input	Block Output Data Type	Scaling
Volts	Double	1

Block Parameters

Channel vector

Enter numbers between 1 and 64. This driver allows you to enter channel numbers in arbitrary order.

For example, to use the first, second, and fifth channels, enter

[1,2,5]

Number the channels beginning with 1 even if this board manufacturer starts numbering the channels with 0.

Range vector

Enter a range code for each of the channels in the channel vector. The range vector must be the same length as the channel vector. This driver allows each channel to be different.

The following table is a list of the ranges for this driver and the corresponding range codes.

Input Range (V)	Range Code
-10 to +10	-10

Input Range (V)	Range Code
-5 to +5	-5
-2.5 to +2.5	-2.5
-1.25 to +1.25	-1.25
0 to +10	10
0 to +5	5
0 to +2.5	2.5
0 to +1.25	1.25

For example, if the first channel is -10 to +10 volts and the second and fifth channels are 0 to +5 volts, enter

[-10,5,5]

Input coupling vector

Enter a coupling code for each of the channels in the channel vector. The coupling vector must be the same length as the channel vector. This driver allows a different coupling for each channel.

The following table is a list of the couplings for this driver and the corresponding coupling codes.

Coupling	Coupling Code	Description
Single- ended	0	Analog input line connected to the positive input. Analog input ground (IGND) internally connected to the negative input.
Differential	1	First analog input line connected to the positive input of the PGIA. Second analog input line connected to the negative input of the PGIA. See the board manual.

For example, if the first and second channels are single input and the fifth channel is a differential input, enter

[0,0,1]

The driver selects a second differential input 32 channels higher than the first channel. In the example above, the driver would select the 37th channel as a differential input with the fifth channel.

Sample time

Enter the base sample time or a multiple of the base sample time (- 1 means sample time is inherited).

PCI slot (-1:autosearch)

If only one board of this type is in the target computer, enter - 1 to locate the board.

If two or more boards of this type are in the target computer, enter the bus number and the PCI slot number of the board associated with this driver block. Use the format **[BusNumber,SlotNumber]**.

To determine the bus number and the PCI slot number, type:

```
tg = slrt;  
getPCIInfo(tg, 'installed')
```

Keithley KPCI-1802HC Analog Output (D/A)

KPCI-1802HC Analog Output block (not recommended)

Library

Simulink Real-Time Library of Drivers No Longer Recommended for Use

Note

The analog output range of this board is set -10 to +10 volts.

Scaling Input to Output

Hardware Output	Block Input Data Type	Scaling
Volts	Double	1

Block Parameters

Channel vector

Enter numbers 1 or 2. This driver allows the selection of individual D/A channels in arbitrary order. The number of elements defines the number of D/A channels used. For example, to use both of the analog output channels, enter

[1,2]

Number the channels beginning with 1 even if this board manufacturer starts numbering the channels with 0.

Reset vector

The reset vector controls the behavior of the channel at model termination. Enter a scalar or a vector that is the same length as the channel vector. If you specify a scalar value, that setting is replicated over the channel vector. If you specify a value of 1, the corresponding channel is reset to the value specified in the initial value vector.

If you specify a value of 0, the channel remains at the last value attained while the model was running.

Initial value vector

The initial value vector contains the initial voltage values for the output channels. Enter a scalar or a vector that is the same length as the channel vector. If you specify a scalar value, that value is replicated as the initial value over the channel vector. The channels are set to the initial values between the time the model is downloaded and the time it is started.

Sample time

Enter the base sample time or a multiple of the base sample time (- 1 means sample time is inherited).

PCI slot (-1:autosearch)

If only one board of this type is in the target computer, enter - 1 to locate the board.

If two or more boards of this type are in the target computer, enter the bus number and the PCI slot number of the board associated with this driver block. Use the format **[BusNumber, SlotNumber]**.

To determine the bus number and the PCI slot number, type:

```
tg = slrt;  
getPCIInfo(tg, 'installed')
```

Keithley KPCI-1802HC Digital Input

KPCI-1802HC Digital Input block (not recommended)

Library

Simulink Real-Time Library of Drivers No Longer Recommended for Use

Scaling Input to Output

Hardware Input	Block Output Data Type	Scaling
TTL	Double	TTL low = 0.0 TTL high = 1.0

Block Parameters

Channel vector

Enter numbers between 1 and 4 to select the digital input lines used with this port. This driver allows the selection of individual digital input lines in arbitrary order. The number of elements defines the number of digital lines used.

For example, to use all of the digital inputs for one port, enter

```
[1,2,3,4]
```

Number the lines beginning with 1 even if this board manufacturer starts numbering the lines with 0.

Sample time

Enter the base sample time or a multiple of the base sample time (-1 means sample time is inherited).

PCI slot (-1:autosearch)

If only one board of this type is in the target computer, enter -1 to locate the board.

If two or more boards of this type are in the target computer, enter the bus number and the PCI slot number of the board associated with this driver block. Use the format **[BusNumber,SlotNumber]**.

To determine the bus number and the PCI slot number, type:

```
tg = slrt;  
getPCIInfo(tg, 'installed')
```

Keithley KPCI-1802HC Digital Output

KPCI-1802HC Digital Output block (not recommended)

Library

Simulink Real-Time Library of Drivers No Longer Recommended for Use

Scaling Input to Output

Hardware Output	Block Input Data Type	Scaling
TTL	Double	< 0.5 = TTL low ≥ 0.5 = TTL high

Block Parameters

Channel vector

Enter numbers between 1 and 8 to select the digital output lines used with this port. This driver allows the selection of individual digital output lines in arbitrary order. The number of elements defines the number of digital lines used.

For example, to use all of the digital outputs for one port, enter

```
[1,2,3,4,5,6,7,8]
```

Number the lines beginning with 1 even if this board manufacturer starts numbering the lines with 0.

Reset vector

The reset vector controls the behavior of the channel at model termination. Enter a scalar or a vector that is the same length as the channel vector. If you specify a scalar value, that setting is replicated over the channel vector. If you specify a value of 1, the corresponding channel is reset to the value specified in the initial value vector. If you specify a value of 0, the channel remains at the last value attained while the model was running.

Initial value vector

The initial value vector contains the initial values (0 or 1) of the output channels. Enter a scalar or a vector that is the same length as the channel vector. If you enter a scalar, that value is replicated as the initial value over the channel vector. The channels are set to these initial values between the time the model is downloaded and the time it is started.

Sample time

Enter the base sample time or a multiple of the base sample time (-1 means sample time is inherited).

PCI slot (-1:autosearch)

If only one board of this type is in the target computer, enter -1 to locate the board.

If two or more boards of this type are in the target computer, enter the bus number and the PCI slot number of the board associated with this driver block. Use the format **[BusNumber,SlotNumber]**.

To determine the bus number and the PCI slot number, type:

```
tg = slrt;  
getPCIInfo(tg, 'installed')
```

MathWorks Drivers No Longer Recommended for Use

The following blocks from the MathWorks library are no longer recommended for use.

LED

Panel LEDs (not recommended)

Watchdog Timer

Watchdog timer (not recommended)

LED

Panel LEDs (not recommended)

Description

Some units have two LEDs that you can control. These LEDs are labeled USER 1 and USER 2.

From the library, drag an LED block into your Simulink model. You can have only one block of this type in a model.

Library

Simulink Real-Time Library of Drivers No Longer Recommended for Use

Block Parameters

LED vector

Enter either 1 and 2. This driver allows the selection of individual LEDs in arbitrary order. The number of elements defines the number of LEDs used. For example, to control the USER 1 and USER 2 LEDs, enter

```
[1 2]
```

Reset vector

Enter 0 or 1 for each LED. This parameter controls the behavior at model termination. A value of 1 causes the corresponding LED to be reset to the value specified in **Initial value vector**. A value of 0 causes the corresponding LED to be left at the most recent value set while the model was running. The **Reset vector** should either be a scalar value or the same length as the LED vector. For scalar values, the block performs a scalar expansion and assumes the same value for each element in the vector.

Initial value vector

Enter 0 or 1 for each LED. This parameter specifies the initial value (0 or 1) to which the LED should be set between the time the model is downloaded and the time it is

started. The **Initial value vector** should be the same length as the LED vector. If the vector does not have the same length, the block performs a scalar expansion and assumes the same value for each element in the vector.

Sample time

Enter the base sample time or a multiple of the base sample time (- 1 means sample time is inherited).

Watchdog Timer

Watchdog timer (not recommended)

Description

On some units, you can program a watchdog to perform a system restart when a programmable timeout occurs. The timeout interval can range from 1 to 255 seconds with one-second resolution, or from 1 to 255 minutes with one-minute resolution. When the timeout expires, an IRQ15 interrupt is asserted. With the **Reboot upon expiration of watchdog** parameter, you can specify that the system restart at this time. At most, one block of this type can be included in a model.

Library

Simulink Real-Time Library of Drivers No Longer Recommended for Use

Block Parameters

Timeout units

From the list, select either **seconds** or **minutes**. These are the units for the time.

Timeout interval

Enter a number between 1 and 255.

Show reset port (R)

Select this check box to display an input port labeled R. A signal connected to this port resets the watchdog whenever its value exceeds 0.5.

Reset upon keyboard activity

Select this check box to reset the watchdog whenever there is keyboard activity.

Reboot upon expiration of watchdog

Select this check box to restart the unit when the watchdog timer expires. When the timeout expires, an IRQ15 interrupt is asserted, regardless of the state of this check box. If you choose not to restart the system when the watchdog timer expires, you might want to write your own procedure to handle the IRQ15 assertion.

Sample time

Enter the base sample time or a multiple of the base sample time (- 1 means sample time is inherited).

Measurement Computing Drivers No Longer Recommended for Use

Measurement Computing CIO-CTR05

Measurement Computing CIO-CTR05 board (not recommended)

Measurement Computing CIO-CTR05 Counter PWM

CIO-CTR05 Counter PWM block (not recommended)

Measurement Computing CIO-CTR05 Counter PWM & ARM

CIO-CTR05 Counter PWM & ARM block (not recommended)

Measurement Computing CIO-CTR05 Counter FM

CIO-CTR05 Counter FM block (not recommended)

Measurement Computing CIO-CTR05 Counter FM & ARM

CIO-CTR05 Counter FM & ARM block (not recommended)

Measurement Computing CIO-CTR05 PWM Capture

CIO-CTR05 PWM Capture block (not recommended)

Measurement Computing CIO-CTR05 Frequency Capture

CIO-CTR05 Frequency Capture block (not recommended)

Measurement Computing CIO-CTR10

CIO-CTR10 counter/timer board (not recommended)

Measurement Computing CIO-CTR10 Counter PWM

CIO-CTR10 Counter PWM (not recommended)

Measurement Computing CIO-CTR10 Counter PWM & ARM

CIO-CTR10 Counter PWM & ARM block (not recommended)

Measurement Computing CIO-CTR10 Counter FM	CIO-CTR10 Counter FM block (not recommended)
Measurement Computing CIO-CTR10 Counter FM & ARM	CIO-CTR10 Counter FM & ARM block (not recommended)
Measurement Computing CIO-CTR10 PWM Capture	CIO-CTR10 PWM Capture block (not recommended)
Measurement Computing CIO-CTR10 Frequency Capture	CIO-CTR10 Frequency Capture block (not recommended)
Measurement Computing CIO-CTRxx	CIO-CTRxx block (not recommended)
Measurement Computing CIO-DAC08 (/12)	Support for the MC CIO-DAC08 (/12) board (not recommended)
Measurement Computing CIO-DAC08 (/12) Analog Output (D/A)	CIO-DAC08 (/12) Analog Output (D/A) block (not recommended)
Measurement Computing CIO-DAC08/16	Support for the MC CIO-DAC08/16 I/O board (not recommended)
Measurement Computing CIO-DAC08/16 Analog Output (D/A)	CIO-DAC08/16 Analog Output (D/A) block (not recommended)
Measurement Computing CIO-DAC16 (/12)	Support for the MC CIO-DAC16 (/12) I/O board (not recommended)
Measurement Computing CIO-DAC16 Analog Output (D/A)	CIO-DAC16 Analog Output (D/A) block (not recommended)
Measurement Computing CIO-DAC16/16	Support for the MC CIO-DAC16/16 I/O board (not recommended)

Measurement Computing CIO-DAC16/16 Analog Output (D/A)	CIO-DAC16/16 Analog Output (D/A) block (not recommended)
Measurement Computing CIO-DAS16/JR (/12)	Support for the MC CIO-DAS16/JR (/12) I/ O board (not recommended)
Measurement Computing CIO-DAS16/JR Analog Input (A/D)	CIO-DAS16/JR Analog Input (A/D) block (not recommended)
Measurement Computing CIO-DAS16/JR (/12) Analog Input (A/D) with EXP	CIO-DAS16/JR (/12) Analog Input with EXP Signal Conditioning Board block (not recommended)
Measurement Computing CIO-DAS16/330	Support for the MC CIO-DAS16/330 I/O board (not recommended)
Measurement Computing CIO-DAS16/330 Analog Input (A/D)	CIO-DAS16/330 Analog Input (A/D) block (not recommended)
Measurement Computing CIO-DAS16JR/16	Support for the MC CIO-DAS16JR/16 I/O board (not recommended)
Measurement Computing CIO-DAS16JR/16 Analog Input (A/D)	CIO-DAS16JR/16 Analog Input block (not recommended)
Measurement Computing CIO-DAS1601/12	Support for the MC CIO-DAS1601/12 I/O board (not recommended)
Measurement Computing CIO-DAS1601/12 Analog Input (A/D)	CIO-DAS1601/12 Analog Input block (not recommended)
Measurement Computing CIO-DAS1601/12 Analog Output (D/A)	CIO-DAS1601/12 Analog Output block (not recommended)

Measurement Computing CIO-DAS1601/12 Digital Input	CIO-DAS1601/12 Digital Input (not recommended)
Measurement Computing CIO-DAS1601/12 Digital Output	CIO-DAS1601/12 Digital Output block (not recommended)
Measurement Computing CIO-DAS1602/12	Support for the MC CIO-DAS1602/12 I/O board (not recommended)
Measurement Computing CIO-DAS1602/12 Analog Input (A/D)	CIO-DAS1602/12 Analog Input block (not recommended)
Measurement Computing CIO-DAS1602/12 Analog Output (D/A)	CIO-DAS1602/12 Analog Output block (not recommended)
Measurement Computing CIO-DAS1602/12 Digital Input	CIO-DAS1602/12 Digital Input block (not recommended)
Measurement Computing CIO-DAS1602/12 Digital Output	CIO-DAS1602/12 Digital Output block (not recommended)
Measurement Computing CIO-DAS1602/16	Support for the MC CIO-DAS1602/16 I/O board (not recommended)
Measurement Computing CIO-DAS1602/16 Analog Input (A/D)	CIO-DAS1602/16 Analog Input block (not recommended)
Measurement Computing CIO-DAS1602/16 Analog Output (D/A)	CIO-DAS1602/16 Analog Output block (not recommended)
Measurement Computing CIO-DAS 1602/16 Digital Input	CIO-DAS 1602/16 Digital Input block (not recommended)
Measurement Computing CIO DAS1602/16 Digital Output	CIO DAS1602/16 Digital Output block (not recommended)

Measurement Computing CIO-DDA06 (/12)	Support for the MC CIO-DDA06 (/12) I/O board (not recommended)
Measurement Computing CIO-DDA06 (/12) Analog Output (D/A)	CIO-DDA06 (/12) Analog Output block (not recommended)
Measurement Computing CIO-DDA06 (/12) Digital Input	CIO-DDA06 (/12) Digital Input (not recommended)
Measurement Computing CIO-DDA06 (/12) Digital Output	CIO-DDA06 (/12) Digital Output block (not recommended)
Measurement Computing CIO-DDA06/16	Support for the MC CIO-DDA06/16 I/O board (not recommended)
Measurement Computing CIO-DDA06/16 Analog Output (D/A)	CIO-DDA06/16 Analog Output block (not recommended)
Measurement Computing CIO-DDA06/16 Digital Input	CIO-DDA06/16 Digital Input block (not recommended)
Measurement Computing CIO-DDA06/16 Digital Output	CIO-DDA06/16 Digital Output block (not recommended)
Measurement Computing CIO-DIO24	Support for the MC CIO-DIO24 I/O board (not recommended)
Measurement Computing CIO-DIO24 Digital Input	CIO-DIO24 Digital Input block (not recommended)
Measurement Computing CIO-DIO24 Digital Output	CIO-DIO24 Digital Output block (not recommended)
Measurement Computing CIO-DIO24H	Support for the MC CIO-DIO24H I/O board (not recommended)

Measurement Computing CIO-DIO24H
Digital Input

CIO-DIO24H Digital Input (not recommended)

Measurement Computing CIO-DIO24H
Digital Output

CIO-DIO24H Digital Output (not recommended)

Measurement Computing CIO-DIO48

Support for the MC CIO-DIO48 I/O board (not recommended)

Measurement Computing CIO-DIO48
Digital Input

CIO-DIO48 Digital Input (not recommended)

Measurement Computing CIO-DIO48
Digital Output

CIO-DIO48 Digital Output block (not recommended)

Measurement Computing CIO-DIO48H

Support for the MC CIO-DIO48H I/O board (not recommended)

Measurement Computing CIO-DIO48H
Digital Input

CIO-DIO48H Digital Input block (not recommended)

Measurement Computing CIO-DIO48H
Digital Output

CIO-DIO48H Digital Output block (not recommended)

Measurement Computing CIO-DIO96

Support for the MC CIO-DIO96 I/O board (not recommended)

Measurement Computing CIO-DIO96
Digital Input

CIO-DIO96 Digital Input block (not recommended)

Measurement Computing CIO-DIO96
Digital Output

CIO-DIO96 Digital Output block (not recommended)

Measurement Computing CIO-DIO192

Support for the MC CIO-DIO192 I/O board (not recommended)

Measurement Computing CIO-DIO192 Digital Input	CIO-DIO192 Digital Input block (not recommended)
Measurement Computing CIO-DIO192 Digital Output	CIO-DIO192 Digital Output block (not recommended)
Measurement Computing CIO-DO24DD	Support for the MC CIO-DO24DD I/O board (not recommended)
Measurement Computing CIO-DO24DD Digital Output	CIO-DO24DD Digital Output block (not recommended)
Measurement Computing CIO-PDISO16	Support for the MC CIO-PDISO16 I/O board (not recommended)
Measurement Computing CIO-PDISO16 Digital Input	CIO-PDISO16 Digital Input block (not recommended)
Measurement Computing CIO-PDISO16 Digital Output	CIO-PDISO16 Digital Output block (not recommended)
Measurement Computing CIO-QUAD02	Support for the MC CIO-QUAD02 counting board (not recommended)
Measurement Computing CIO-QUAD02 Incremental Encoder	CIO-QUAD02 Incremental Encoder block (not recommended)
Measurement Computing CIO-QUAD04	Support for the MC CIO-QUAD04 counting board (not recommended)
Measurement Computing CIO-QUAD04 Incremental Encoder	CIO-QUAD04 Incremental Encoder block (not recommended)
Measurement Computing PCI-QUAD04 Incremental Encoder	PCI-QUAD04 Incremental Encoder block (not recommended)

Measurement Computing PCI-CTR05

Measurement Computing PCI-CTR05 board (not recommended)

Measurement Computing PCI-CTR05 Counter PWM

PCI-CTR05 Counter PWM block (not recommended)

Measurement Computing PCI-CTR05 Counter PWM & ARM

PCI-CTR05 Counter PWM & ARM block (not recommended)

Measurement Computing PCI-CTR05 Counter FM

PCI-CTR05 Counter FM block (not recommended)

Measurement Computing PCI-CTR05 Counter FM & ARM

PCI-CTR05 Counter FM & ARM block (not recommended)

Measurement Computing PCI-CTR05 PWM Capture

PCI-CTR05 PWM Capture block (not recommended)

Measurement Computing PCI-CTR05 Frequency Capture

PCI-CTR05 Frequency Capture block (not recommended)

Measurement Computing PCI-CTRxx

PCI-CTRxx block (not recommended)

Measurement Computing PCI-DAS1002

Support for the MC PCI-DAS1002 I/O board (not recommended)

Measurement Computing PCI-DAS1002 Analog Input (A/D)

PCI-DAS1002 Analog Input block (not recommended)

Measurement Computing PCI-DAS1002 Analog Output (D/A)

PCI-DAS1002 Analog Output block (not recommended)

Measurement Computing PCI-DAS1002 Digital Input

PCI-DAS1002 Digital Input block (not recommended)

Measurement Computing PCI-DAS1002 Digital Output	PCI-DAS1002 Digital Output block (not recommended)
Measurement Computing PCI-DAS1200	Support for the MC PCI-DAS1200 I/O board (not recommended)
Measurement Computing PCI-DAS1200 Analog Input (A/D)	PCI-DAS1200 Analog Input block (not recommended)
Measurement Computing PCI-DAS1200 Analog Output (D/A)	PCI-DAS1200 Analog Output block (not recommended)
Measurement Computing PCI-DAS1200 Digital Input	PCI-DAS1200 Digital Input block (not recommended)
Measurement Computing PCI-DAS1200 Digital Output	PCI-DAS1200 Digital Output block (not recommended)
Measurement Computing PCI-DAS1200/JR	Support for the MC PCI-DAS1200/JR I/O board (not recommended)
Measurement Computing PCI-DAS1200/JR Analog Input (A/D)	PCI-DAS1200/JR Analog Input block (not recommended)
Measurement Computing PCI-DAS1200/JR Digital Input	PCI-DAS1200/JR Digital Input block (not recommended)
Measurement Computing PCI-DAS1200/JR Digital Output	PCI-DAS1200/JR Digital Output block (not recommended)
Measurement Computing PCI-DAS1602/12	Support for the MC PCI-DAS1602/12 I/O board (not recommended)
Measurement Computing PCI-DAS1602/12 Analog Input (A/D)	PCI-DAS1602/12 Analog Input block (not recommended)

Measurement Computing PCI-DAS1602/12 Analog Output (D/A)	PCI-DAS1602/12 Analog Output block (not recommended)
Measurement Computing PCI-DAS 1602/12 Digital Input	PCI-DAS 1602/12 Digital Input (not recommended)
Measurement Computing PCI-DAS1602/12 Digital Output	PCI-DAS1602/12 Digital Output (not recommended)
Measurement Computing PCI-DAS1602/16	Support for the MC PCI-DAS1602/16 I/O board (not recommended)
Measurement Computing PCI-DAS1602/16 Analog Input (A/D)	PCI-DAS1602/16 Analog Input block (not recommended)
Measurement Computing PCI-DAS1602/16 Analog Output (D/A)	PCI-DAS1602/16 Analog Output block (not recommended)
Measurement Computing PCI-DAS 1602/16 Digital Input	PCI-DAS 1602/16 Digital Input block (not recommended)
Measurement Computing PCI-DAS1602/16 Digital Output	PCI-DAS1602/16 Digital Output block (not recommended)

Measurement Computing CIO-CTR05

Measurement Computing CIO-CTR05 board (not recommended)

Board

Measurement Computing CIO-CTR05

General Description

The CIO-CTR05 is an I/O board with five counter/timer channels (16-bit).

It contains one AM9513A counter/timer chip. For additional information about the various counter/timer modes of that chip see the AM9513A data sheet which is part of the board documentation.

The Simulink Real-Time product supports this board with these driver blocks:

- Measurement Computing CIO-CTR05 Counter PWM
- Measurement Computing CIO-CTR05 Counter PWM & ARM
- Measurement Computing CIO-CTR05 Counter FM
- Measurement Computing CIO-CTR05 Counter FM & ARM
- Measurement Computing CIO-CTR05 PWM Capture
- Measurement Computing CIO-CTR05 Frequency Capture
- Measurement Computing CIO-CTRxx

Board Characteristics

Board name	CIO-CTR05
Manufacturer	Measurement Computing
Bus type	ISA
Access method	I/O mapped
Multiple block instance support	Yes

Multiple board support

Yes

Measurement Computing CIO-CTR05 Counter PWM

CIO-CTR05 Counter PWM block (not recommended)

Library

Simulink Real-Time Library of Drivers No Longer Recommended for Use

Note

The CIO-CTR05 has one AM9513A chip with five counters.

The CIO-CTR05 PWM driver programs the AM9513A for PWM (Pulse Width Modulation) signal generation (a square wave with fixed frequency and variable duty cycle). The block has one input which defines the variable duty cycle between 0 and 1. For the corresponding counter channel, the PWM signal is output at the pin named OUT.

Scaling Input to Output

I/O Module Output	Block Input Data Type	Scaling
TTL	Double	0 to 1

Block Parameters

Counter

From the list, choose 1, 2, 3, 4, or 5 to select which counter is used with this driver block. One block is required for each counter used.

Frequency base

From the list, choose F1=5MHz, F2=500kHz, F3=50kHz, F4=5kHz, or F5=500Hz to set the base frequency. The XTAL frequency is assumed to be 1 MHz, therefore the jumper on the CIO-CTR05 has to be in position 1 MHz not 5 MHz.

Relative output frequency

Enter a value between 0 and 0.25. The **Relative output frequency** is multiplied by the **Frequency base** to set the fixed output frequency of the PWM-signal.

For example, if the output frequency of a square wave has to be 17.5 kHz, then choose $F_2=100\text{kHz}$ as the **Frequency base** and enter 0.175 as the **Relative output frequency**. $100\text{ kHz} \times 0.175 = 17.5\text{ kHz}$

Level sequence of square wave

From the list, choose either **high-low** or **low-high**:

- If you choose **high-low**, the square wave period starts with the TTL high part followed by the TTL low part.
- If you choose **low-high**, the square wave period starts with the TTL low part followed by the TTL high part.

In either case, the duty cycle entering the block defines the duration of the TTL high part.

Level when disarmed

From the list, choose either **high** or **low**. The counter is automatically disarmed when the real-time application is not running and gets armed when the application begins running. This parameter sets the TTL level when the counter is disarmed.

Sample time

Enter the base sample time or a multiple of the base sample time. The sample time indicates the update rate of registration on the input (Duty Cycle)

Base address

Enter the base address of the board. This entry must correspond to the DIP switch setting on the board. For example, if the DIP switch setting is 300 (hexadecimal), enter **0x300**.

Measurement Computing CIO-CTR05 Counter PWM & ARM

CIO-CTR05 Counter PWM & ARM block (not recommended)

Library

Simulink Real-Time Library of Drivers No Longer Recommended for Use

Note

The CIO-CTR05 has one AM9513A chip with five counters.

The CIO-CTR05 PWM & ARM driver programs the AM9513A for PWM or disarmed signal generation (a square wave with fixed frequency and variable duty cycle). Additionally the driver allows to arm and disarm the counter by the second block input. For the corresponding counter channel, the PWM signal is output at the pin named OUT.

Scaling Input to Output

I/O Module Output	Block Input Data Type	Scaling
TTL	Duty cycle: Double Arm: Double	0 to 1 <0.5 disarmed ≥0.5 armed

Block Parameters

Counter

From the list, choose 1, 2, 3, 4, or 5 to select which counter is used with this driver block. One block is required for each counter used.

Frequency base

From the list, choose F1=5MHz, F2=500kHz, F3=50kHz, F4=5kHz, or F5=500Hz to set the base frequency. The XTAL frequency is assumed to be 1 MHz, therefore the jumper on the CIO-CTR05 has to be in position 1 MHz not 5 MHz.

Relative output frequency

Enter a value between 0 and 0.25. The **Relative output frequency** is multiplied by the **Frequency base** to set the fixed output frequency of the PWM-signal.

For example, if the output frequency of a square wave has to be 17.5 kHz, then choose F2=100kHz as the **Frequency base** and enter 0.175 as the **Relative output frequency**. $100 \text{ kHz} \times 0.175 = 17.5 \text{ kHz}$

Level sequence of square wave

From the list, choose either **high-low** or **low-high**:

- If you choose **high-low**, the square wave period starts with the TTL high part followed by the TTL low part.
- If you choose **low-high**, the square wave period starts with the TTL low part followed by the TTL high part.

In either case, the duty cycle entering the block defines the duration of the TTL high part.

Level when disarmed

From the list, choose either **high** or **low**. The counter is automatically disarmed when the real-time application is not running. If the application is running, the second input port controls whether the counter is armed or disarmed. This parameter sets the TTL level when the counter is disarmed.

Sample time

Enter the base sample time or a multiple of the base sample time. The sample time indicates the update rate of registration on the input (Duty Cycle)

Base address

Enter the base address of the board. This entry must correspond to the DIP switch setting on the board. For example, if the DIP switch setting is 300 (hexadecimal), enter 0x300.

Measurement Computing CIO-CTR05 Counter FM

CIO-CTR05 Counter FM block (not recommended)

Library

Simulink Real-Time Library of Drivers No Longer Recommended for Use

Note

The CIO-CTR05 has one AM9513A chip with five counters.

The CIO-CTR05 FM driver programs the AM9513A for FM (Frequency Modulation) signal generation (a square wave with fixed duty cycle and variable frequency). For the corresponding counter channel, the PWM signal is output at the pin named OUT.

Scaling Input to Output

I/O Module Output	Block Input Data Type	Scaling
TTL	Double	0 to 1

Block Parameters

Counter

From the list, choose 1, 2, 3, 4, or 5 to select which counter is used with this driver block. One block is required for each counter used.

Frequency base

From the list, choose F1=5MHz, F2=500kHz, F3=50kHz, F4=5kHz, or F5=500Hz to set the base frequency. The XTAL frequency is assumed to be 1 MHz, therefore the jumper on the CIO-CTR05 has to be in position 1 MHz not 5 MHz.

Output duty cycle

Enter a value between 0 and 1 to set the duty cycle of the square wave. The Duty Cycle is held fixed during execution of the real-time application.

Note: Your control over the output duty cycle is not precise. See “PWM and FM Driver Block Notes” on page 1-9 for details.

Level sequence of square wave

From the list, choose either **high-low** or **low-high**:

- If you choose **high-low**, the square wave period starts with the TTL high part followed by the TTL low part.
- If you choose **low-high**, the square wave period starts with the TTL low part followed by the TTL high part.

In either case, the duty cycle entering the block defines the duration of the TTL high part.

Level when disarmed

From the list, choose either **high** or **low**. The counter is automatically disarmed when the real-time application is not running and gets armed when the application begins running. This parameter sets the TTL level when the counter is disarmed.

Sample time

Enter the base sample time or a multiple of the base sample time. The sample time indicates the update rate of registration on the input (Duty Cycle)

Base address

Enter the base address of the board. This entry must correspond to the DIP switch setting on the board. For example, if the DIP switch setting is 300 (hexadecimal), enter **0x300**.

Measurement Computing CIO-CTR05 Counter FM & ARM

CIO-CTR05 Counter FM & ARM block (not recommended)

Library

Simulink Real-Time Library of Drivers No Longer Recommended for Use

Note

The CIO-CTR05 has one AM9513A chip with five counters.

The CIO-CTR05 FM & ARM driver programs the AM9513A for FM (Frequency Modulation) signal generation (a square wave with fixed duty cycle and variable frequency). Additionally the driver allows to arm and disarm the counter by the second block input. For the corresponding counter channel, the PWM signal is output at the pin named OUT.

Scaling Input to Output

I/O Module Output	Block Input Data Type	Scaling
TTL	Variable frequency: Double Arm: Double	<0.5 unarmed ≥0.5 armed

Block Parameters

Counter

From the list, choose 1, 2, 3, 4 or, 5 to select which counter is used with this driver block. One block is required for each counter used.

Frequency base

From the list, choose F1=5MHz, F2=500kHz, F3=50kHz, F4=5kHz, or F5=500Hz to set the base frequency. The XTAL frequency is assumed to be 1 MHz, therefore the jumper on the CIO-CTR05 has to be in position 1 MHz not 5 MHz.

Output duty cycle

Enter a value between 0 and 1 to set the duty cycle of the square wave. The Duty Cycle is held fixed during execution of the real-time application.

Note: Your control over the output duty cycle is not precise. See “PWM and FM Driver Block Notes” on page 1-9 for details.

Level sequence of square wave

From the list, choose either **high-low** or **low-high**:

- If you choose **high-low**, the square wave period starts with the TTL high part followed by the TTL low part.
- If you choose **low-high**, the square wave period starts with the TTL low part followed by the TTL high part.

In either case, the **Output duty cycle** defined in the setting above define the duration of the TTL high part.

Level when disarmed

From the list, choose either **high** or **low**. The counter is automatically disarmed when the real-time application is not running. If the application is running, the second input port controls whether the counter is armed or disarmed. This parameter sets the TTL level when the counter is disarmed.

Sample time

Enter the base sample time or a multiple of the base sample time. The sample time indicates the update rate of registration on the input (Duty Cycle)

Base address

Enter the base address of the board. This entry must correspond to the DIP switch setting on the board. For example, if the DIP switch setting is 300 (hexadecimal), enter 0x300.

Measurement Computing CIO-CTR05 PWM Capture

CIO-CTR05 PWM Capture block (not recommended)

Library

Simulink Real-Time Library of Drivers No Longer Recommended for Use

Note

This block programs the AMD9513A for capturing PWM signals by using two counters. One counter measures the cycle duration, and the other counter measures the duration the signal is high.

There are two outputs. One output is the relative frequency compared to the base frequency. The other output is the duty cycle. To get the actual frequency, multiply the base frequency by the relative frequency.

The PWM signal has to enter the pins named GATE of both corresponding counter channels (parallel wiring). Both CLK pins have to be left unconnected.

Scaling Input to Output

I/O Module Output	Block Input Data Type	Scaling
TTL	Double	0 to 1

Block Parameters

Counter

From the list, choose 1&2, 2&3, 3&4, 4&5. This selects which two counters the driver block uses to determine the PWM. One block is required for each counter used.

Frequency base

From the list, choose F1=5MHz, F2=500kHz, F3=50kHz, F4=5kHz, or F5=500Hz to set the base frequency. The XTAL frequency is assumed to be 1 MHz, therefore the jumper on the CIO-CTR05 has to be in position 1 MHz not 5 MHz.

Sample time

Enter the base sample time or a multiple of the base sample time. The sample time indicates the update rate of registration on the input (Duty Cycle)

Base address

Enter the base address of the board. This entry must correspond to the DIP switch setting on the board. For example, if the DIP switch setting is 300 (hexadecimal), enter 0x300.

Measurement Computing CIO-CTR05 Frequency Capture

CIO-CTR05 Frequency Capture block (not recommended)

Library

Simulink Real-Time Library of Drivers No Longer Recommended for Use

Note

This block programs the AMD9513A for capturing FM signals.

There is one output for relative frequency compared to the base frequency. To get the actual frequency, multiply the base frequency by the relative frequency.

The FM signal has to enter the pin named GATE of the corresponding counter channel. The CLK pin has to be left unconnected.

Scaling Input to Output

I/O Module Output	Block Input Data Type	Scaling
TTL	Double	0 to 1

Block Parameters

Counter

From the list, choose 1, 2, 3, 4, or 5. This selects which counter the driver block uses to determine the FM. One block is required for each counter used.

Frequency base

From the list, choose F1=5MHz, F2=500kHz, F3=50kHz, F4=5kHz, or F5=500Hz to set the base frequency. The XTAL frequency is assumed to be 1 MHz, therefore the jumper on the CIO-CTR05 has to be in position 1 MHz not 5 MHz.

Sample time

Enter the base sample time or a multiple of the base sample time. The sample time indicates the update rate of registration on the input (Duty Cycle)

Base address

Enter the base address of the board. This entry must correspond to the DIP switch setting on the board. For example, if the DIP switch setting is 300 (hexadecimal), enter 0x300.

Measurement Computing CIO-CTR10

CIO-CTR10 counter/timer board (not recommended)

Board

Measurement Computing CIO-CTR10

General Description

The CIO-CTR10 is an I/O board with ten counter/timer channels (16-bit).

It contains one AM9513A counter/timer chip. For additional information about the various counter/timer modes of that chip see the AM9513A data sheet which is part of the board documentation.

The Simulink Real-Time block library supports this board with these driver blocks:

- Measurement Computing CIO-CTR10 Counter PWM
- Measurement Computing CIO-CTR10 Counter PWM & ARM
- Measurement Computing CIO-CTR10 Counter FM
- Measurement Computing CIO-CTR10 Counter FM & ARM
- Measurement Computing CIO-CTR10 PWM Capture
- Measurement Computing CIO-CTR10 Frequency Capture
- Measurement Computing CIO-CTRxx

Board Characteristics

Board name	CIO-CTR10
Manufacturer	Measurement Computing
Bus type	ISA
Access method	I/O mapped
Multiple block instance support	Yes

Multiple board support

Yes

Measurement Computing CIO-CTR10 Counter PWM

CIO-CTR10 Counter PWM (not recommended)

Library

Simulink Real-Time Library of Drivers No Longer Recommended for Use

Note

The CIOCTR10 has one AM9513A chip with ten counters.

The CIO-CTR10 PWM driver programs the AM9513A for PWM (Pulse Width Modulation) signal generation (a square wave with fixed frequency and variable duty cycle). The block has one input which defines the variable duty cycle between 0 and 1. For the corresponding counter channel, the PWM signal is output at the pin named OUT.

Scaling Input to Output

I/O Module Output	Block Input Data Type	Scaling
TTL	Double	0 to 1

Block Parameters

Counter

From the list, choose 1, 2, 3, 4, or 5 to select which counter is used with this driver block. One block is required for each counter used.

Frequency base

From the list, choose F1=1MHz, F2=100kHz, F3=10kHz, F4=1kHz, or F5=100Hz to set the base frequency. The XTAL frequency is assumed to be 1 MHz, therefore the jumper on the CIO-CTR10 has to be in position 1 MHz not 5 MHz.

Relative output frequency

Enter a value between 0 and 0.25. The **Relative output frequency** is multiplied by the **Frequency base** to set the fixed output frequency of the PWM-signal.

For example, if the output frequency of a square wave has to be 17.5 kHz, then choose $F_2=100\text{kHz}$ as the **Frequency base** and enter 0.175 as the **Relative output frequency**. $100\text{ kHz} \times 0.175 = 17.5\text{ kHz}$

Level sequence of square wave

From the list, choose either **high-low** or **low-high**:

- If you choose **high-low**, the square wave period starts with the TTL high part followed by the TTL low part.
- If you choose **low-high**, the square wave period starts with the TTL low part followed by the TTL high part.

In either case, the duty cycle entering the block defines the duration of the TTL high part.

Level when disarmed

From the list, choose either **high** or **low**. The counter is automatically disarmed when the real-time application is not running and gets armed when the application begins running. This parameter sets the TTL level when the counter is disarmed.

Sample time

Enter the base sample time or a multiple of the base sample time. The sample time indicates the update rate of registration on the input (Duty Cycle)

Base address

Enter the base address of the board. This entry must correspond to the DIP switch setting on the board. For example, if the DIP switch setting is 300 (hexadecimal), enter **0x300**.

Measurement Computing CIO-CTR10 Counter PWM & ARM

CIO-CTR10 Counter PWM & ARM block (not recommended)

Library

Simulink Real-Time Library of Drivers No Longer Recommended for Use

Note

The CIO-CTR10 has two AM9513A chip with ten counters.

The CIO-CTR10 PWM & ARM driver programs the AM9513A for PWM or disarmed signal generation (a square wave with fixed frequency and variable duty cycle). Additionally the driver allows to arm and disarm the counter by the second block input. For the corresponding counter channel, the PWM signal is output at the pin named OUT.

Scaling Input to Output

I/O Module Output	Block Input Data Type	Scaling
TTL	Duty cycle: Double Arm: Double	0 to 1 <0.5 disarmed ≥0.5 armed

Block Parameters

Counter

From the list, choose 1, 2, 3, 4, or 5 to select which counter is used with this driver block. One block is required for each counter used.

Frequency base

From the list, choose F1=1MHz, F2=100kHz, F3=10kHz, F4=1kHz, or F5=100Hz to set the base frequency. The XTAL frequency is assumed to be 1 MHz, therefore the jumper on the CIO-CTR10 has to be in position 1 MHz not 5 MHz.

Relative output frequency

Enter a value between 0 and 0.25. The **Relative output frequency** is multiplied by the **Frequency base** to set the fixed output frequency of the PWM-signal.

For example, if the output frequency of a square wave has to be 17.5 kHz, then choose F2=100kHz as the **Frequency base** and enter 0.175 as the **Relative output frequency**. $100 \text{ kHz} \times 0.175 = 17.5 \text{ kHz}$

Level sequence of square wave

From the list, choose either **high-low** or **low-high**:

- If you choose **high-low**, the square wave period starts with the TTL high part followed by the TTL low part.
- If you choose **low-high**, the square wave period starts with the TTL low part followed by the TTL high part.

In either case, the duty cycle entering the block defines the duration of the TTL high part.

Level when disarmed

From the list, choose either **high** or **low**. The counter is automatically disarmed when the real-time application is not running. If the application is running, the second input port controls whether the counter is armed or disarmed. This parameter sets the TTL level when the counter is disarmed.

Sample time

Enter the base sample time or a multiple of the base sample time. The sample time indicates the update rate of registration on the input (Duty Cycle)

Base address

Enter the base address of the board. This entry must correspond to the DIP switch setting on the board. For example, if the DIP switch setting is 300 (hexadecimal), enter 0x300.

Measurement Computing CIO-CTR10 Counter FM

CIO-CTR10 Counter FM block (not recommended)

Library

Simulink Real-Time Library of Drivers No Longer Recommended for Use

Note

The CIO-CTR10 has two AM9513A chip with ten counters.

The CIO-CTR10 FM driver programs the AM9513A for FM (Frequency Modulation) signal generation (a square wave with fixed duty cycle and variable frequency). For the corresponding counter channel, the PWM signal is output at the pin named OUT.

Scaling Input to Output

I/O Module Output	Block Input Data Type	Scaling
TTL	Double	0 to 1

Block Parameters

Counter

From the list, choose 1, 2, 3, 4, or 5 to select which counter is used with this driver block. One block is required for each counter used.

Frequency base

From the list, choose F1=1MHz, F2=100kHz, F3=10kHz, F4=1kHz, or F5=100Hz to set the base frequency. XTAL frequency is assumed to be 1 MHz, therefore the jumper on the CIO-CTR10 has to be in position 1 MHz not 5 MHz.

Output duty cycle

Enter a value between 0 and 1 to set the duty cycle of the square wave. The Duty Cycle is held fixed during execution of the real-time application.

Note: Your control over the output duty cycle is not precise. See “PWM and FM Driver Block Notes” on page 1-9 for details.

Level sequence of square wave

From the list, choose either **high-low** or **low-high**:

- If you choose **high-low**, the square wave period starts with the TTL high part followed by the TTL low part.
- If you choose **low-high**, the square wave period starts with the TTL low part followed by the TTL high part.

In either case, the duty cycle entering the block defines the duration of the TTL high part.

Level when disarmed

From the list, choose either **high** or **low**. The counter is automatically disarmed when the real-time application is not running and gets armed when the application begins running. This parameter sets the TTL level when the counter is disarmed.

Sample time

Enter the base sample time or a multiple of the base sample time. The sample time indicates the update rate of registration on the input (Duty Cycle)

Base address

Enter the base address of the board. This entry must correspond to the DIP switch setting on the board. For example, if the DIP switch setting is 300 (hexadecimal), enter **0x300**.

Measurement Computing CIO-CTR10 Counter FM & ARM

CIO-CTR10 Counter FM & ARM block (not recommended)

Library

Simulink Real-Time Library of Drivers No Longer Recommended for Use

Note

The CIO-CTR10 has two AM9513A chips with ten counters.

The CIO-CTR10 FM & ARM driver programs the AM9513A for FM (Frequency Modulation) signal generation (a square wave with fixed duty cycle and variable frequency). Additionally the driver allows to arm and disarm the counter by the second block input. For the corresponding counter channel, the PWM signal is output at the pin named OUT.

Scaling Input to Output

I/O Module Output	Block Input Data Type	Scaling
TTL	Variable frequency: Double Arm: Double	<0.5 disarmed ≥0.5 armed

Block Parameters

Counter

From the list, choose 1, 2, 3, 4, 5, 6, 7, 8, 9, or 10 to select which counter is used with this driver block. One block is required for each counter used.

Frequency base

From the list, choose F1=1MHz, F2=100kHz, F3=10kHz, F4=1kHz, or F5=100Hz to set the base frequency. The XTAL frequency is assumed to be 1 MHz, therefore the jumper on the CIO-CTR10 has to be in position 1 MHz not 5 MHz.

Output duty cycle

Enter a value between 0 and 1 to set the duty cycle of the square wave. The Duty Cycle is held fixed during execution of the real-time application.

Note: Your control over the output duty cycle is not precise. See “PWM and FM Driver Block Notes” on page 1-9 for details.

Level sequence of square wave

From the list, choose either **high-low** or **low-high**:

- If you choose **high-low**, the square wave period starts with the TTL high part followed by the TTL low part.
- If you choose **low-high**, the square wave period starts with the TTL low part followed by the TTL high part.

In either case, the **Output duty cycle** defined in the setting above define the duration of the TTL high part.

Level when disarmed

From the list, choose either **high** or **low**. The counter is automatically disarmed when the real-time application is not running. If the application is running, the second input port controls whether the counter is armed or disarmed. This parameter sets the TTL level when the counter is disarmed.

Sample time

Enter the base sample time or a multiple of the base sample time. The sample time indicates the update rate of registration on the input (Duty Cycle)

Base address

Enter the base address of the board. This entry must correspond to the DIP switch setting on the board. For example, if the DIP switch setting is 300 (hexadecimal), enter 0x300.

Measurement Computing CIO-CTR10 PWM Capture

CIO-CTR10 PWM Capture block (not recommended)

Library

Simulink Real-Time Library of Drivers No Longer Recommended for Use

Note

This block programs the AMD9513A for capturing PWM signals by using two counters. One counter measures the cycle duration, and the other counter measures the duration the signal is high.

There are two outputs. One output is the relative frequency compared to the base frequency. The other output is the duty cycle. To get the actual frequency, multiply the base frequency by the relative frequency.

The PWM signal has to enter the pins named GATE of both corresponding counter channels (parallel wiring). Both CLK pins have to be left unconnected.

Scaling Input to Output

I/O Module Output	Block Input Data Type	Scaling
TTL	Double	0 to 1

Block Parameters

Counter

From the list, choose 1&2, 2&3, 3&4, 4&5, 5&6, 6&7, 7&8, 8&9, 9&10. This selects which two counters the driver block uses to determine the PWM. One block is required for each counter used.

Frequency base

From the list, choose F1=1MHz, F2=100kHz, F3=10kHz, F4=1kHz, or F5=100Hz to set the base frequency. The XTAL frequency is assumed to be 1 MHz, therefore the jumper on the CIO-CTR10 has to be in position 1 MHz not 5 MHz.

Sample time

Enter the base sample time or a multiple of the base sample time. The sample time indicates the update rate of registration on the input (Duty Cycle)

Base address

Enter the base address of the board. This entry must correspond to the DIP switch setting on the board. For example, if the DIP switch setting is 300 (hexadecimal), enter 0x300.

Measurement Computing CIO-CTR10 Frequency Capture

CIO-CTR10 Frequency Capture block (not recommended)

Library

Simulink Real-Time Library of Drivers No Longer Recommended for Use

Note

This block programs the AMD9513A for capturing FM signals.

There is one output for relative frequency compared to the base frequency. To get the actual frequency, multiply the base frequency by the relative frequency.

The FM signal has to enter the pin named GATE of the corresponding counter channel. The CLK pin has to be left unconnected.

Scaling Input to Output

I/O Module Output	Block Input Data Type	Scaling
TTL	Double	0 to 1

Block Parameters

Counter

From the list, choose 1, 2, 3, 4, 5, 6, 7, 8, 9, or 10. This selects which counter the driver block uses to determine the FM. One block is required for each counter used.

Frequency base

From the list, choose F1=1MHz, F2=100kHz, F3=10kHz, F4=1kHz, or F5=100Hz to set the base frequency. The XTAL frequency is assumed to be 1 MHz, therefore the jumper on the CIO-CTR10 has to be in position 1 MHz not 5 MHz.

Sample time

Enter the base sample time or a multiple of the base sample time. The sample time indicates the update rate of registration on the input (Duty Cycle).

Base address

Enter the base address of the board. This entry must correspond to the DIP switch setting on the board. For example, if the DIP switch setting is 300 (hexadecimal), enter `0x300`.

Measurement Computing CIO-CTRxx

CIO-CTRxx block (not recommended)

Library

Simulink Real-Time Library of Drivers No Longer Recommended for Use

Description

You can use this block to program the AMD9513A counter. The PWM, PWM & ARM, FM, FM & ARM, PWM Capture, and Frequency Capture blocks use this block in their underlying subsystems. The API for this block is not currently documented.

Measurement Computing CIO-DAC08 (/12)

Support for the MC CIO-DAC08 (/12) board (not recommended)

Board

CIO-DAC08 (/12)

General Description

The CIO-DAC08 (/12) is an I/O board with eight analog output (D/A) channels (12-bit).

The Simulink Real-Time block library supports this board with this driver block:

- Measurement Computing CIO-DAC08 (/12) Analog Output (D/A)

Board Characteristics

Board name	CIO-DAC08 (CIO-DAC08/12)
Manufacturer	Measurement Computing
Bus type	ISA
Access method	I/O mapped
Multiple block instance support	Yes
Multiple board support	Yes

Measurement Computing CIO-DAC08 (/12) Analog Output (D/A)

CIO-DAC08 (/12) Analog Output (D/A) block (not recommended)

Library

Simulink Real-Time Library of Drivers No Longer Recommended for Use

Scaling Input to Output

I/O Module Output	Block Input Data Type	Scaling
Volts	Double	1

Block Parameters

Channel vector

Enter numbers between 1 and 8. This board allows the selection of individual D/A channels in arbitrary order. The number of elements defines the number of D/A channels used. For example, to use the first and second analog output (D/A) channels, enter

```
[1,2]
```

Number the channels beginning with 1 even if this board manufacturer starts numbering the channels with 0.

Range vector

Range code for each of the channels in the channel vector. The range vector must have the same length as the channel vector. This board allows the range of each channel to be different.

The following table is a list of the ranges for this driver and the corresponding range codes.

Input Range (V)	Range Code
-10 to +10	-10
-5 to +5	-5
0 to 10	10
0 to 5	5

For example, if the first channel is -10 to +10 volts and the second channel is 0 to +5 volts, enter

[-10,5]

The range settings must correspond to the DIP switch settings on the board.

Reset vector

The reset vector controls the behavior of the channel at model termination. Enter a scalar or a vector that is the same length as the channel vector. If you specify a scalar value, that setting is replicated over the channel vector. If you specify a value of 1, the corresponding channel is reset to the value specified in the initial value vector. If you specify a value of 0, the channel remains at the last value attained while the model was running.

Initial value vector

The initial value vector contains the initial voltage values for the output channels. Enter a scalar or a vector that is the same length as the channel vector. If you specify a scalar value, that value is replicated as the initial value over the channel vector. The channels are set to the initial values between the time the model is downloaded and the time it is started.

Sample time

Enter the base sample time or a multiple of the base sample time (-1 means sample time is inherited).

Base address

Enter the base address of the board. This entry must correspond to the DIP switch setting on the board. For example, if the DIP switch setting is 300 (hexadecimal), enter 0x300.

Measurement Computing CIO-DAC08/16

Support for the MC CIO-DAC08/16 I/O board (not recommended)

Board

Measurement Computing CIO-DAC08/16

General Description

The CIO-DAC08/16 is an I/O board with 8 analog output (D/A) channels (16-bit).

The Simulink Real-Time block library supports this board with this driver block:

- Measurement Computing CIO-DAC08/16 Analog Output (D/A)

Board Characteristics

Board name	CIO-DAC08/16
Manufacturer	Measurement Computing
Bus type	ISA
Access method	I/O mapped
Multiple block instance support	Yes
Multiple board support	Yes

Measurement Computing CIO-DAC08/16 Analog Output (D/A)

CIO-DAC08/16 Analog Output (D/A) block (not recommended)

Library

Simulink Real-Time Library of Drivers No Longer Recommended for Use

Scaling Input to Output

I/O Module Output	Block Input Data Type	Scaling
Volts	Double	1

Block Parameters

Channel vector

Enter numbers between 1 and 8. This board allows the selection of individual D/A channels in arbitrary order. The number of elements defines the number of D/A channels used. For example, to use the first and second analog output (D/A) channels, enter

[1,2]

Number the channels beginning with 1 even if this board manufacturer starts numbering the channels with 0.

Range vector

Range code for each of the channels in the channel vector. The range vector must be the same length as the channel vector. This driver allows the range of each channel to be different.

The following table is a list of the ranges for this driver and the corresponding range codes.

Input Range (V)	Range Code
-10 to +10	-10
-5 to +5	-5
0 to +10	10
0 to +5	5

For example, if the first channel is -10 to +10 volts and the second channel is 0 to +5 volts, enter

[-10,5]

The range settings must correspond to the DIP switch settings on the board.

Reset vector

The reset vector controls the behavior of the channel at model termination. Enter a scalar or a vector that is the same length as the channel vector. If you specify a scalar value, that setting is replicated over the channel vector. If you specify a value of 1, the corresponding channel is reset to the value specified in the initial value vector. If you specify a value of 0, the channel remains at the last value attained while the model was running.

Initial value vector

The initial value vector contains the initial voltage values for the output channels. Enter a scalar or a vector that is the same length as the channel vector. If you specify a scalar value, that value is replicated as the initial value over the channel vector. The channels are set to the initial values between the time the model is downloaded and the time it is started.

Sample time

Enter the base sample time or a multiple of the base sample time (-1 means sample time is inherited).

Base address

Enter the base address of the board. This entry must correspond to the DIP switch setting on the board. For example, if the DIP switch setting is 300 (hexadecimal), enter 0x300.

Measurement Computing CIO-DAC16 (/12)

Support for the MC CIO-DAC16 (/12) I/O board (not recommended)

Board

Measurement Computing CIO-DAC16 (/12)

General Description

The CIO-DAC016 is an I/O board with 16 analog output (D/A) channels (12-bit).

The Simulink Real-Time block library supports this board with one driver block:

- Measurement Computing CIO-DAC16 Analog Output (D/A)

Board Characteristics

Board name	CIO-DAC16 (/12)
Manufacturer	Measurement Computing
Bus type	ISA
Access method	I/O mapped
Multiple block instance support	Yes
Multiple board support	Yes

Measurement Computing CIO-DAC16 Analog Output (D/A)

CIO-DAC16 Analog Output (D/A) block (not recommended)

Library

Simulink Real-Time Library of Drivers No Longer Recommended for Use

Scaling Input to Output

I/O Module Output	Block Input Data Type	Scaling
Volts	Double	1

Block Parameters

Channel vector

Enter numbers between 1 and 16. This driver allows the selection of individual D/A channels in arbitrary order. The number of elements defines the number of D/A channels used. For example, to use the first and second analog output (D/A) channels, enter

```
[1,2]
```

Number the channels beginning with 1 even if this board manufacturer starts numbering the channels with 0.

Range vector

Enter a range code for each of the channels in the channel vector. The range vector must be the same length as the channel vector. This board allows the range of each channel to be different.

The following table is a list of the ranges for this driver and the corresponding range codes.

Input Range (V)	Range Code
-10 to +10	-10
-5 to +5	-5
-2.5 to +2.5	-2.5
0 to +10	10
0 to +5	5
0 to +2.5	2.5

For example, if the first channel is -10 to +10 volts and the second channel is 0 to +5 volts, enter

[-10,5]

The range settings must correspond to the DIP switch settings on the board.

Reset vector

The reset vector controls the behavior of the channel at model termination. Enter a scalar or a vector that is the same length as the channel vector. If you specify a scalar value, that setting is replicated over the channel vector. If you specify a value of 1, the corresponding channel is reset to the value specified in the initial value vector. If you specify a value of 0, the channel remains at the last value attained while the model was running.

Initial value vector

The initial value vector contains the initial voltage values for the output channels. Enter a scalar or a vector that is the same length as the channel vector. If you specify a scalar value, that value is replicated as the initial value over the channel vector. The channels are set to the initial values between the time the model is downloaded and the time it is started.

Sample time

Enter the base sample time or a multiple of the base sample time (- 1 means sample time is inherited).

Base address

Enter the base address of the board. It is important that this entry corresponds to the DIP switch settings on the board. For example, if the base address is 300 (hexadecimal), enter

0x300

The jumpers by the range DIP switches on the board must be in the XFER position.
The Wait-State jumper has to be in the off position.

Measurement Computing CIO-DAC16/16

Support for the MC CIO-DAC16/16 I/O board (not recommended)

Board

Measurement Computing CIO-DAC16/16

General Description

The CIO-DAC16/16 is an I/O board with 16 analog output (D/A) channels (16-bit).

The Simulink Real-Time block library supports this board with this driver block:

- Measurement Computing CIO-DAC16/16 Analog Output (D/A)

Board Characteristics

Board name	CIO-DAC08/16
Manufacturer	Measurement Computing
Bus type	ISA
Access method	I/O mapped
Multiple block instance support	Yes
Multiple board support	Yes

Measurement Computing CIO-DAC16/16 Analog Output (D/A)

CIO-DAC16/16 Analog Output (D/A) block (not recommended)

Library

Simulink Real-Time Library of Drivers No Longer Recommended for Use

Scaling Input to Output

I/O Module Output	Block Input Data Type	Scaling
Volts	Double	1

Block Parameters

Channel vector

Enter numbers between 1 and 16. This board allows the selection of individual A/D channels in arbitrary order. The number of elements defines the number of D/A channels used. For example, to use the first and second analog output (D/A) channels, enter

[1,2]

Number the channels beginning with 1 even if this board manufacturer starts numbering the channels with 0.

Range vector

Enter a range code for each of the channels in the channel vector. The range vector must be the same length as the channel vector. This board allows the range of each channel to be different.

The following table is a list of the ranges for this driver and the corresponding range codes.

Input Range (V)	Range Code
-10 to +10	-10
-5 to +5	-5
-2.5 to +2.5	-2.5
0 to +10	10
0 to +5	5
0 to +2.5	2.5

For example, if the first channel is -10 to +10 volts and the second channel is 0 to +5 volts, enter

[-10,5]

The range settings must correspond to the DIP switch settings on the board.

Reset vector

The reset vector controls the behavior of the channel at model termination. Enter a scalar or a vector that is the same length as the channel vector. If you specify a scalar value, that setting is replicated over the channel vector. If you specify a value of 1, the corresponding channel is reset to the value specified in the initial value vector. If you specify a value of 0, the channel remains at the last value attained while the model was running.

Initial value vector

The initial value vector contains the initial voltage values for the output channels. Enter a scalar or a vector that is the same length as the channel vector. If you specify a scalar value, that value is replicated as the initial value over the channel vector. The channels are set to the initial values between the time the model is downloaded and the time it is started.

Sample time

Enter the base sample time or a multiple of the base sample time (- 1 means sample time is inherited).

Base address

Enter the base address of the board. It is important that this entry corresponds to the DIP switch settings on the board. For example, if the base address is 300 (hexadecimal), enter

0x300

The jumpers by the range DIP switches on the board must be in the XFER position.
The Wait-State jumper has to be in the off position.

Measurement Computing CIO-DAS16/JR (/12)

Support for the MC CIO-DAS16/JR (/12) I/O board (not recommended)

Board

Measurement Computing CIO-DAS16/JR (/12)

General Description

The CIO-DAS16/JR is an I/O board with 16 single or 8 differential analog input (A/D) channels (12-bit) with a maximum sample rate of 130 kHz, 4 digital input lines, 4 digital output lines, and 3 counter/timers (16-bit). An external signal conditioning board can be added to the CIO-DAS16/JR board.

The Simulink Real-Time block library supports this board with these driver blocks:

- Measurement Computing CIO-DAS16/JR Analog Input (A/D)
- Measurement Computing CIO-DAS16/JR (/12) Analog Input (A/D) with EXP

Note: The Simulink Real-Time software does not support the digital I/O or counters on this board.

Board Characteristics

Board name	CIO-DAS16/JR
Manufacturer	Measurement Computing
Bus type	ISA
Access method	I/O mapped
Multiple block instance support	No
Multiple board support	Yes

Measurement Computing CIO-DAS16/JR Analog Input (A/D)

CIO-DAS16/JR Analog Input (A/D) block (not recommended)

Library

Simulink Real-Time Library of Drivers No Longer Recommended for Use

Scaling Input to Output

I/O Module Input	Block Output Data Type	Scaling
Volts	Double	1

Block Parameters

Number of Channels

If you select 16 channels (**Input coupling** parameter set to 16 **single-ended channels**) enter a number between 1 and 16 to select the number of A/D channels used. If you select eight channels (**Input coupling** parameter set to 8 **differential channels**) enter a number between 1 and 8. This driver does not allow the selection of individual channels or to mix single-ended and differential inputs.

Number the lines beginning with 1 even if this board manufacturer starts numbering the lines with 0.

Range

From the list, choose either $\pm 10V$ (-10 volts to +10 volts), $\pm 5V$, $\pm 2.5V$, $\pm 1.25V$, $\pm 0.625V$, 0-10V, 0-5V, 0-2.5V, or 0-1.25V. This driver does not allow the selection of a different range for each channel.

Input coupling

From the list, select one from the following list of input modes:

- Single-ended (16 channels)
- Differential (8 channels)

This choice must correspond to the MUX-switch setting on the board.

Sample time

Enter the base sample time or a multiple of the base sample time (- 1 means sample time is inherited).

Base address

Enter the base address of the board. This entry must correspond to the DIP switch setting on the board. For example, if the DIP switch setting is 300 (hexadecimal), enter 0x300.

Measurement Computing CIO-DAS16/JR (/12) Analog Input (A/D) with EXP

CIO-DAS16/JR (/12) Analog Input with EXP Signal Conditioning Board block (not recommended)

Library

Simulink Real-Time Library of Drivers No Longer Recommended for Use

Scaling Input to Output

I/O Module Input	Block Output Data Type	Scaling
Volts	Double	1

There are signal conditioning boards (external devices) available from Measurement Computing which can be connected to the CIO-DAS16/JR. Each EXP-board contains its own multiplexer circuit which multiplexes a maximum number of 16 EXP-channels to one A/D-channel of the CIO-DAS16/JR. For this type of operation the CIO-DAS16/JR has to be setup for single-ended input mode and this results in a theoretical number of 256 EXP-channels per CIO-DAS/16JR board.

- EXP16
- EXP32
- EXP-BRIDGE16
- EXP-RTD
- EXP-GP

Block Parameters

EXP Channel vector

This parameter describes the EXP-channels used. Because a group of 16 EXP-channels are mapped to one A/D-channel of the CIO-DAS16/JR, the EXP-channel vector must contain unique elements between 0 and 15. The number of elements of

the vector defines the number of block outputs. The EXP-channel defined as the first element is output at the first block output, the EXP-channel defined as the second element is output at the second block output and so on.

Example: EXP Channel Vector: [4,0,12]
the Signal of EXP-channel 4 is output at block outut 1
the Signal of EXP-channel 0 is output at block outut 2
the Signal of EXP-channel 12 is output at block outut 3

If an EXP32 is used and the EXP-channels 16 to 31 should be acquired, the elements of the EXP Channel Vector have still to be in the range of 0 to 15. Therefore the EXP-channel numbers have to be subsaturated by the constant 16.

A special case is provided by setting the EXP Channel Vector to an empty vector. In this case it is assumed that an EXP-board is not connected to the specified A/D-channel (see dialog field A/D Board Channel) and the signal is directly connected to the A/D-input of the CIO-DAS16Jr board. This feature allows you to use the A/D-channels of a CIO-DAS16Jr either for EXP-channels or for direct input.

This feature should only be used if at least one EXP-board has to be connected to the CIO-DAS16Jr. If all inputs are directly connected to the A/D board, use the CIO-DAS16Jr/12 (2.2.1) driver instead, which allows much higher sample rates.

EXP Gain

This parameter describes the gains for each EXP-channel used. This vector corresponds over his indices with the EXP-gain vector and must therefore have the same length. Because this I/O-driver can be used together with different EXP-boards, the gain value itself is not restricted. The EXP-board manual should be contacted to know what the gains of the different EXP-boards are. The gains on the EXP-board depend on several DIP switches on the specific EXP-board.

Example:
EXP Channel Vector: [4,0,12]
EXP Gain Vector: [1,1000,200]
EXP-channel 4 has gain 1, channel 0 gain 1000 and channel 12 gain 200

If EXP Channel Vector is an empty vector EXP Gain Vector has to be an empty vector as well.

A/D Board Channel

This field specifies to which A/D-channel of the CIO-DAS16Jr the block of 16 EXP-channels are mapped. Because the input coupling of the A/D board has to be single-ended channel 0 to 16 can be used. The channel selection jumpers on the EXP-boards have to be set accordingly to this software setting.

A/D Board Range

This field specifies the input voltage range for the CIO-DAS16/JR, which is the same for the 16 single-ended channels.

From the list, choose either $\pm 10V$ (-10 volts to +10 volts), $\pm 5V$, $\pm 2.5V$, $\pm 1.25V$, $\pm 0.625V$, $0-10V$, $0-5V$, $0-2.5V$, or $0-1.25V$. This driver does not allow the selection of different range for each channel.

Sample time

Enter the base sample time or a multiple of the base sample time (- 1 means sample time is inherited).

Base address

Enter the base address of the board. It is important that this entry corresponds to the DIP switch settings on the board. For example, if the base address is 300 (hexadecimal), enter

0x300

Note: If this driver is used, the input coupling switch on the CIO-DAS16Jr must be in the 16 (single-ended) position.

Measurement Computing CIO-DAS16/330

Support for the MC CIO-DAS16/330 I/O board (not recommended)

Board

Measurement Computing CIO-DAS16/330

General Description

The CIO-DAS16/330 is an I/O board with 16 single or 8 differential analog input (A/D) channels (12-bit) with a maximum sample rate of 330 kHz, 4 digital input lines, and 4 digital output lines.

The Simulink Real-Time block library supports this board with one driver block:

- Measurement Computing CIO-DAS16/330 Analog Input (A/D)

Note: The Simulink Real-Time product does not support the digital I/O on this board.

Board Characteristics

Board name	CIO-DAS16/330
Manufacturer	Measurement Computing
Bus type	ISA
Access method	I/O mapped
Multiple block instance support	No
Multiple board support	Yes

Measurement Computing CIO-DAS16/330 Analog Input (A/D)

CIO-DAS16/330 Analog Input (A/D) block (not recommended)

Library

Simulink Real-Time Library of Drivers No Longer Recommended for Use

Scaling Input to Output

I/O Module Input	Block Output Data Type	Scaling
Volts	Double	1

Block Parameters

Number of Channels

If you select 16 channels (**Input coupling** parameter set to 16 **single-ended channels**) enter a number between 1 and 16 to select the number of A/D channels used. If you select eight channels (**Input coupling** parameter set to 8 **differential channels**) enter a number between 1 and 8. This driver does not allow the selection of individual channels or to mix single-ended and differential inputs.

Number the lines beginning with 1 even if this board manufacturer starts numbering the lines with 0.

Range

From the list, choose either $\pm 10V$ (-10 volts to +10 volts), $\pm 5V$, $\pm 2.5V$, $\pm 1.25V$, $\pm 0.625V$, $0-10V$, $0-5V$, $0-2.5V$, or $0-1.25V$. This driver does not allow the selection of different range for each channel.

Input coupling

From the list, select one from the following list of input modes:

- Single-ended (16 channels)
- Differential (8 channels)

This choice must correspond to the MUX-switch setting on the board.

Sample time

Enter the base sample time or a multiple of the base sample time (- 1 means sample time is inherited).

Base address

Enter the base address of the board. This entry must correspond to the DIP switch setting on the board. For example, if the DIP switch setting is 300 (hexadecimal), enter 0x300.

Measurement Computing CIO-DAS16JR/16

Support for the MC CIO-DAS16JR/16 I/O board (not recommended)

Board

Measurement Computing CIO-DAS16JR/16

General Description

The CIO-DAS16JR/16 is an I/O board with 16 single or 8 differential analog input (A/D) channels (16-bit) with a maximum sample rate of 100 kHz, 4 digital input lines, 4 digital output lines and 3 counter/timers.

The Simulink Real-Time block library supports this board with this driver block:

- Measurement Computing CIO-DAS16JR/16 Analog Input (A/D)

Note: The Simulink Real-Time software does not support the digital I/O or the counters on this board.

Board Characteristics

Board name	CIO-DAS16JR/16
Manufacturer	Measurement Computing
Bus type	ISA
Access method	I/O mapped
Multiple block instance support	No
Multiple board support	Yes

Measurement Computing CIO-DAS16JR/16 Analog Input (A/D)

CIO-DAS16JR/16 Analog Input block (not recommended)

Library

Simulink Real-Time Library of Drivers No Longer Recommended for Use

Scaling Input to Output

I/O Module Input	Block Output Data Type	Scaling
Volts	Double	1

Block Parameters

Number of Channels

If you select 16 channels (**Input coupling** parameter set to 16 **single-ended channels**) enter a number between 1 and 16 to select the number of A/D channels used. If you select eight channels (**Input coupling** parameter set to 8 **differential channels**) enter a number between 1 and 8. This driver does not allow the selection of individual channels or to mix single-ended and differential inputs.

Number the lines beginning with 1 even if this board manufacturer starts numbering the lines with 0.

Range

From the list, choose either $\pm 10V$ (-10 volts to +10 volts), $\pm 5V$, $\pm 2.5V$, $\pm 1.25V$, $\pm 0.625V$, $0-10V$, $0-5V$, $0-2.5V$, or $0-1.25V$. This driver does not allow the selection of a different range for each channel.

Input coupling

From the list, select one of the input modes:

- Single-ended channels (16 channels)
- Differential channels (8 channels)

This choice must correspond to the MUX-switch setting on the board.

Sample time

Enter the base sample time or a multiple of the base sample time (- 1 means sample time is inherited).

Base address

Enter the base address of the board. This entry must correspond to the DIP switch setting on the board. For example, if the DIP switch setting is 300 (hexadecimal), enter 0x300.

Measurement Computing CIO-DAS1601/12

Support for the MC CIO-DAS1601/12 I/O board (not recommended)

Board

Measurement Computing CIO-DAS1601/12

General Description

The CIO-DAS1601/12 is an I/O board with 16 single or 8 differential analog input (A/D) channels (12-bit) with a maximum sampling rate of 160 kHz, 2 analog output (D/A) channels (12-bit), 32 digital input and output lines, and 3 counters (16-bit).

The Simulink Real-Time block library supports this board with these driver blocks:

- Measurement Computing CIO-DAS1601/12 Analog Input (A/D)
- Measurement Computing CIO-DAS1601/12 Analog Output (D/A)
- Measurement Computing CIO-DAS1601/12 Digital Input
- Measurement Computing CIO-DAS1601/12 Digital Output

Note: The Simulink Real-Time software supports only 24 digital I/O lines and does not support the counters on this board.

Board Characteristics

Board name	CIO-DAS1601/12
Manufacturer	Measurement Computing
Bus type	ISA
Access method	I/O mapped
Multiple block instance support	A/D: No, D/A: Yes, Digital I/O: Yes
Multiple board support	Yes

Measurement Computing CIO-DAS1601/12 Analog Input (A/D)

CIO-DAS1601/12 Analog Input block (not recommended)

Library

Simulink Real-Time Library of Drivers No Longer Recommended for Use

Scaling Input to Output

I/O Module Input	Block Output Data Type	Scaling
Volts	Double	1

Block Parameters

Number of Channels

If you select 16 channels (**Input coupling** parameter set to 16 **single-ended channels**) enter a number between 1 and 16 to select the number of A/D channels used. If you select eight channels (**Input coupling** parameter set to 8 **differential channels**) enter a number between 1 and 8. This driver does not allow the selection of individual channels or to mix single-ended and differential inputs.

Number the lines beginning with 1 even if this board manufacturer starts numbering the lines with 0.

Range

From the list, choose either $\pm 10V$ (-10 volts to +10 volts), $\pm 5V$, $\pm 2.5V$, $\pm 1.25V$, $\pm 0.625V$, $0-10V$, $0-5V$, $0-2.5V$, or $0-1.25V$. This driver does not allow the selection of a different range for each channel.

If a bipolar range is used, the bipolar switch on the board must be in the bipolar position. If a unipolar range is used, the bipolar switch must be in the unipolar position.

Input coupling

From the list, select one from the following list of input modes:

- Single-ended channels (16 channels)
- Differential channels (8 channels)

This choice must correspond to the MUX-switch setting on the board.

Sample time

Enter the base sample time or a multiple of the base sample time (- 1 means sample time is inherited).

Base address

Enter the base address of the board. This entry must correspond to the DIP switch setting on the board. For example, if the DIP switch setting is 300 (hexadecimal), enter 0x300.

Measurement Computing CIO-DAS1601/12 Analog Output (D/A)

CIO-DAS1601/12 Analog Output block (not recommended)

Library

Simulink Real-Time Library of Drivers No Longer Recommended for Use

Scaling Input to Output

I/O Module Output	Block Input Data Type	Scaling
Volts	Double	1

Block Parameters

Channel vector

Enter 1 or 2. This driver allows the selection of individual D/A channels in arbitrary order. The number of elements defines the number of D/A channels used. For example, to use the first and second analog output (D/A) channels, enter

[1,2]

Number the channels beginning with 1 even if this board manufacturer starts numbering the channels with 0.

Range vector

Enter a range code for each of the channels in the channel vector. The range vector must be the same length as the channel vector. This board allows the range of each channel to be different.

The following table is a list of the ranges for this driver and the corresponding range codes.

Input Range (V)	Range Code
-10 to +10	-10

Input Range (V)	Range Code
-5 to +5	-5
0 to +10	10
0 to +5	5

For example, if the first channel is -10 to +10 volts and the second channel is 0 to +5 volts, enter

```
[ -10,5]
```

The range settings must correspond to the DIP switch settings on the board. Also the bipolar/unipolar jumpers must be placed according to the ranges used.

Reset vector

The reset vector controls the behavior of the channel at model termination. Enter a scalar or a vector that is the same length as the channel vector. If you specify a scalar value, that setting is replicated over the channel vector. If you specify a value of 1, the corresponding channel is reset to the value specified in the initial value vector. If you specify a value of 0, the channel remains at the last value attained while the model was running.

Initial value vector

The initial value vector contains the initial voltage values for the output channels. Enter a scalar or a vector that is the same length as the channel vector. If you specify a scalar value, that value is replicated as the initial value over the channel vector. The channels are set to the initial values between the time the model is downloaded and the time it is started.

Sample time

Enter the base sample time or a multiple of the base sample time (- 1 means sample time is inherited).

Base address

Enter the base address of the board. This entry must correspond to the DIP switch setting on the board. For example, if the DIP switch setting is 300 (hexadecimal), enter 0x300.

Measurement Computing CIO-DAS1601/12 Digital Input

CIO-DAS1601/12 Digital Input (not recommended)

Library

Simulink Real-Time Library of Drivers No Longer Recommended for Use

Note

The DAS1601/12 has an 8255 chip with 3 ports (A,B,C). Each port has a maximum of 8 digital I/O lines that can be configured as inputs or outputs.

Use a separate driver block for each port. By selecting the digital input driver block, the port is configured as input.

Scaling Input to Output

I/O Module Input	Block Output Data Type	Scaling
TTL	Double	TTL low = 0.0 TTL high = 1.0

Block Parameters

Channel vector

Enter numbers between 1 and 8 to select the digital input lines used with this port. This driver allows the selection of individual digital input lines in arbitrary order. The number of elements defines the number of digital lines used.

For example, to use all of the digital inputs for one port, enter

```
[1,2,3,4,5,6,7,8]
```

Number the lines beginning with 1 even if this board manufacturer starts numbering the lines with 0.

Port

From the list choose either A, B, or C. The I/O board has an 8255 chip with 3 ports. The port name defines which port of the 8255 chip is used for this driver block. Each port has a maximum of 8 digital lines that can be configured as inputs or outputs depending on which driver block is chosen. In each case, one block is required for each port.

Sample time

Enter the base sample time or a multiple of the base sample time (- 1 means sample time is inherited).

Base address

Enter the base address of the board. This entry must correspond to the DIP switch setting on the board. For example, if the DIP switch setting is 300 (hexadecimal), enter 0x300.

Measurement Computing CIO-DAS1601/12 Digital Output

CIO-DAS1601/12 Digital Output block (not recommended)

Library

Simulink Real-Time Library of Drivers No Longer Recommended for Use

Note

The DAS1601/12 has an 8255 chip with 3 ports (A,B,C). Each port has a maximum of 8 digital I/O lines that can be configured as inputs or outputs.

Use a separate driver block for each port. By selecting the digital output driver block, the port is configured as output.

Scaling Input to Output

I/O Module Output	Block Input Data Type	Scaling
TTL	Double	$< 0.5 = \text{TTL low}$ $\geq 0.5 = \text{TTL high}$

Block Parameters

Channel vector

Enter numbers between 1 and 8 to select the digital output lines used with this port. This driver allows the selection of individual digital output lines in arbitrary order. The number of elements defines the number of digital lines used.

For example, to use all of the digital outputs for one port, enter

[1,2,3,4,5,6,7,8]

Number the lines beginning with 1 even if this board manufacturer starts numbering the lines with 0.

Port

From the list choose either A, B, or C. The I/O board has an 8255 chip with 3 ports. The port name defines which port of the 8255 chip is used for this driver block. Each port has a maximum of 8 digital lines that can be configured as inputs or outputs depending on which driver block is chosen. In each case, one block is required for each port.

Reset vector

The reset vector controls the behavior of the channel at model termination. Enter a scalar or a vector that is the same length as the channel vector. If you specify a scalar value, that setting is replicated over the channel vector. If you specify a value of 1, the corresponding channel is reset to the value specified in the initial value vector. If you specify a value of 0, the channel remains at the last value attained while the model was running.

Initial value vector

The initial value vector contains the initial values (0 or 1) of the output channels. Enter a scalar or a vector that is the same length as the channel vector. If you enter a scalar, that value is replicated as the initial value over the channel vector. The channels are set to these initial values between the time the model is downloaded and the time it is started.

Sample time

Enter the base sample time or a multiple of the base sample time (- 1 means sample time is inherited).

Base address

Enter the base address of the board. This entry must correspond to the DIP switch setting on the board. For example, if the DIP switch setting is 300 (hexadecimal), enter 0x300.

Measurement Computing CIO-DAS1602/12

Support for the MC CIO-DAS1602/12 I/O board (not recommended)

Board

Measurement Computing CIO-DAS1602/12

General Description

The CIO-DAS1602/12 is an I/O board with 16 single or 8 differential analog input (A/D) channels (12-bit) with a maximum sampling rate of 100 kHz, 2 analog output (D/A) channels (12-bit), 32 digital input and output lines, and 3 counters (16-bit).

The Simulink Real-Time block library supports this board with these driver blocks:

- Measurement Computing CIO-DAS1602/12 Analog Input (A/D)
- Measurement Computing CIO-DAS1602/12 Analog Output (D/A)
- Measurement Computing CIO-DAS1602/12 Digital Input
- Measurement Computing CIO-DAS1602/12 Digital Output

Note: The Simulink Real-Time software supports only 24 digital I/O lines and does not support the counters on this board.

Board Characteristics

Board Name	CIO-DAS1602/12
Manufacturer	Measurement Computing
Bus type	ISA
Access method	I/O mapped
Multiple block instance support	A/D: No, D/A: Yes, Digital I/O: Yes
Multiple board support	Yes

Measurement Computing CIO-DAS1602/12 Analog Input (A/D)

CIO-DAS1602/12 Analog Input block (not recommended)

Library

Simulink Real-Time Library of Drivers No Longer Recommended for Use

Scaling Input to Output

I/O Module Input	Block Output Data Type	Scaling
Volts	Double	1

Block Parameters

Number of Channels

If you select 16 channels (**Input coupling** parameter set to **16 single-ended channels**) enter a number between 1 and 16 to select the number of A/D channels used. If you select eight channels (**Input coupling** parameter set to **8 differential channels**) enter a number between 1 and 8. This driver does not allow the selection of individual channels or to mix single-ended and differential inputs.

Range

From the list, choose either **+ -10V** (-10 volts to +10 volts), **+ -5V**, **+ -2.5V**, **+ -1.25V**, **+ -0.625V**, **0 -10V**, **0 -5V**, **0 -2.5V**, or **0 -1.25V**. This driver does not allow the selection of a different range for each channel.

If a bipolar range is used, the bipolar switch on the board must be in the bipolar position. if a unipolar range is used, the bipolar switch must be in the unipolar position.

Input coupling

From the list, select one from the following list of input modes:

- Single-ended channels (16 channels)
- Differential channels (8 channels)

This choice must correspond to the MUX-switch setting on the board.

Sample time

Enter the base sample time or a multiple of the base sample time (- 1 means sample time is inherited).

Base address

Enter the base address of the board. This entry must correspond to the DIP switch setting on the board. For example, if the DIP switch setting is 300 (hexadecimal), enter 0x300.

Measurement Computing CIO-DAS1602/12 Analog Output (D/A)

CIO-DAS1602/12 Analog Output block (not recommended)

Library

Simulink Real-Time Library of Drivers No Longer Recommended for Use

Scaling Input to Output

I/O Module Output	Block Input Data Type	Scaling
Volts	Double	1

Block Parameters

Channel vector

Enter 1 or 2. This driver allows the selection of individual D/A channels in arbitrary order. The number of elements defines the number of D/A channels used. For example, to use the first and second analog output (D/A) channels, enter

[1,2]

Number the channels beginning with 1 even if this board manufacturer starts numbering the channels with 0.

Range vector

Enter a range code for each of the channels in the channel vector. The range vector must be the same length as the channel vector. This board allows the range of each channel to be different.

The following table is a list of the ranges for this driver and the corresponding range codes.

Input Range (V)	Range Code
-10 to +10	-10

Input Range (V)	Range Code
-5 to +5	-5
0 to +10	10
0 to +5	5

For example, if the first channel is -10 to +10 volts and the second channel is 0 to +5 volts, enter

[-10,5]

The range settings must correspond to the DIP switch settings on the board. Also the bipolar/unipolar jumpers must be planted according to the ranges used.

Reset vector

The reset vector controls the behavior of the channel at model termination. Enter a scalar or a vector that is the same length as the channel vector. If you specify a scalar value, that setting is replicated over the channel vector. If you specify a value of 1, the corresponding channel is reset to the value specified in the initial value vector. If you specify a value of 0, the channel remains at the last value attained while the model was running.

Initial value vector

The initial value vector contains the initial voltage values for the output channels. Enter a scalar or a vector that is the same length as the channel vector. If you specify a scalar value, that value is replicated as the initial value over the channel vector. The channels are set to the initial values between the time the model is downloaded and the time it is started.

Sample time

Enter the base sample time or a multiple of the base sample time (- 1 means sample time is inherited).

Base address

Enter the base address of the board. This entry must correspond to the DIP switch setting on the board. For example, if the DIP switch setting is 300 (hexadecimal), enter 0x300.

Measurement Computing CIO-DAS1602/12 Digital Input

CIO-DAS1602/12 Digital Input block (not recommended)

Library

Simulink Real-Time Library of Drivers No Longer Recommended for Use

Note

The DAS1601/12 has an 8255 chip with 3 ports (A,B,C). Each port has a maximum of 8 digital I/O lines that can be configured as inputs or outputs.

Use a separate driver block for each port. By selecting the digital input driver block, the port is configured as input.

Scaling Input to Output

I/O Module Input	Block Output Data Type	Scaling
TTL	Double	TTL low = 0.0 TTL high = 1.0

Block Parameters

Channel vector

Enter numbers between 1 and 8 to select the digital input lines used with this port. This driver allows the selection of individual digital input lines in arbitrary order. The number of elements defines the number of digital lines used.

For example, to use all of the digital inputs for one port, enter

```
[1,2,3,4,5,6,7,8]
```

Number the lines beginning with 1 even if this board manufacturer starts numbering the lines with 0.

Port

From the list choose either A, B, or C. The I/O board has an 8255 chip with 3 ports. The port name defines which port of the 8255 chip is used for this driver block. Each port has a maximum of 8 digital lines that can be configured as inputs or outputs depending on which driver block is chosen. In each case, one block is required for each port.

Sample time

Enter the base sample time or a multiple of the base sample time (- 1 means sample time is inherited).

Base address

Enter the base address of the board. This entry must correspond to the DIP switch setting on the board. For example, if the DIP switch setting is 300 (hexadecimal), enter 0x300.

Measurement Computing CIO-DAS1602/12 Digital Output

CIO-DAS1602/12 Digital Output block (not recommended)

Library

Simulink Real-Time Library of Drivers No Longer Recommended for Use

Note

The DAS1601/12 has an 8255 chip with 3 ports (A,B,C). Each port has a maximum of 8 digital I/O lines that can be configured as inputs or outputs.

Use a separate driver block for each port. By selecting the digital output driver block, the port is configured as output.

Scaling Input to Output

I/O Module Output	Block Input Data Type	Scaling
TTL	Double	< 0.5 = TTL low ≥ 0.5 = TTL high

Block Parameters

Channel vector

Enter numbers between 1 and 8 to select the digital output lines used with this port. This driver allows the selection of individual digital output lines in arbitrary order. The number of elements defines the number of digital lines used.

For example, to use all of the digital outputs for one port, enter

```
[1,2,3,4,5,6,7,8]
```

Number the lines beginning with 1 even if this board manufacturer starts numbering the lines with 0.

Port

From the list choose either A, B, or C. The I/O board has an 8255 chip with 3 ports. The port name defines which port of the 8255 chip is used for this driver block. Each port has a maximum of 8 digital lines that can be configured as inputs or outputs depending on which driver block is chosen. In each case, one block is required for each port.

Reset vector

The reset vector controls the behavior of the channel at model termination. Enter a scalar or a vector that is the same length as the channel vector. If you specify a scalar value, that setting is replicated over the channel vector. If you specify a value of 1, the corresponding channel is reset to the value specified in the initial value vector. If you specify a value of 0, the channel remains at the last value attained while the model was running.

Initial value vector

The initial value vector contains the initial values (0 or 1) of the output channels. Enter a scalar or a vector that is the same length as the channel vector. If you enter a scalar, that value is replicated as the initial value over the channel vector. The channels are set to these initial values between the time the model is downloaded and the time it is started.

Sample time

Enter the base sample time or a multiple of the base sample time (-1 means sample time is inherited).

Base address

Enter the base address of the board. This entry must correspond to the DIP switch setting on the board. For example, if the DIP switch setting is 300 (hexadecimal), enter 0x300.

Measurement Computing CIO-DAS1602/16

Support for the MC CIO-DAS1602/16 I/O board (not recommended)

Board

Measurement Computing CIO-DAS1602/16

The CIO-DAS1602/16 is an I/O board with 16 single or 8 differential analog input (A/D) channels (16-bit) with a maximum sampling rate of 100 kHz, 2 analog output (D/A) channels (16-bit), 32 digital I/O lines, and 3 counters (16-bit).

The Simulink Real-Time block library supports this board with these driver blocks:

- Measurement Computing CIO-DAS1602/16 Analog Input (A/D)
- Measurement Computing CIO-DAS1602/16 Analog Output (D/A)
- Measurement Computing CIO-DAS 1602/16 Digital Input
- Measurement Computing CIO DAS1602/16 Digital Output

Note: The Simulink Real-Time software supports only 24 digital I/O lines and does not support the counters on this board.

Board Characteristics

Board Name	CIO-DAS1602/16
Manufacturer	Measurement Computing
Bus type	ISA
Access method	I/O mapped
Multiple block instance support	A/D: No, D/A: Yes, Digital I/O: Yes
Multiple board support	Yes

Measurement Computing CIO-DAS1602/16 Analog Input (A/D)

CIO-DAS1602/16 Analog Input block (not recommended)

Library

Simulink Real-Time Library of Drivers No Longer Recommended for Use

Scaling Input to Output

I/O Module Input	Block Output Data Type	Scaling
Volts	Double	1

Block Parameters

Number of Channels

If you select 16 channels (**Input coupling** parameter set to 16 **single-ended channels**) enter a number between 1 and 16 to select the number of A/D channels used. If you select eight channels (**Input coupling** parameter set to 8 **differential channels**) enter a number between 1 and 8. This driver does not allow the selection of individual channels or to mix single-ended and differential inputs.

Range

From the list, choose either $\pm 10V$ (-10 volts to +10 volts), $\pm 5V$, $\pm 2.5V$, $\pm 1.25V$, $\pm 0.625V$, $0-10V$, $0-5V$, $0-2.5V$, or $0-1.25V$. This driver does not allow the selection of a different range for each channel.

If a bipolar range is used, the bipolar switch on the board must be in the bipolar position. If a unipolar range is used, the bipolar switch must be in the unipolar position.

Input coupling

From the list, select one from the following list of input modes:

- Single-ended channels (16 channels)
- Differential channels (8 channels)

Sample time

Enter the base sample time or a multiple of the base sample time (- 1 means sample time is inherited).

Base address

Enter the base address of the board. This entry must correspond to the DIP switch setting on the board. For example, if the DIP switch setting is 300 (hexadecimal), enter 0x300.

Measurement Computing CIO-DAS1602/16 Analog Output (D/A)

CIO-DAS1602/16 Analog Output block (not recommended)

Library

Simulink Real-Time Library of Drivers No Longer Recommended for Use

Scaling Input to Output

I/O Module Output	Block Input Data Type	Scaling
Volts	Double	1

Block Parameters

Channel vector

Enter 1 or 2. This driver allows the selection of individual D/A channels in arbitrary order. The number of elements defines the number of D/A channels used. For example, to use the first and second analog output (D/A) channels, enter

[1,2]

Number the channels beginning with 1 even if this board manufacturer starts numbering the channels with 0.

Range vector

Enter a range code for each of the channels in the channel vector. The range vector must be the same length as the channel vector. This board allows the range of each channel to be different.

The following table is a list of the ranges for this driver and the corresponding range codes.

Input Range (V)	Range Code
-10 to +10	-10

Input Range (V)	Range Code
-5 to +5	-5
0 to +10	10
0 to +5	5

For example, if the first channel is -10 to +10 volts and the second channel is 0 to +5 volts, enter

```
[ -10,5]
```

The range settings must correspond to the DIP switch settings on the board. Also the bipolar/unipolar jumpers must be planted according to the ranges used.

Reset vector

The reset vector controls the behavior of the channel at model termination. Enter a scalar or a vector that is the same length as the channel vector. If you specify a scalar value, that setting is replicated over the channel vector. If you specify a value of 1, the corresponding channel is reset to the value specified in the initial value vector. If you specify a value of 0, the channel remains at the last value attained while the model was running.

Initial value vector

The initial value vector contains the initial voltage values for the output channels. Enter a scalar or a vector that is the same length as the channel vector. If you specify a scalar value, that value is replicated as the initial value over the channel vector. The channels are set to the initial values between the time the model is downloaded and the time it is started.

Sample time

Enter the base sample time or a multiple of the base sample time (- 1 means sample time is inherited).

Base address

Enter the base address of the board. This entry must correspond to the DIP switch setting on the board. For example, if the DIP switch setting is 300 (hexadecimal), enter 0x300.

Measurement Computing CIO-DAS 1602/16 Digital Input

CIO-DAS 1602/16 Digital Input block (not recommended)

Library

Simulink Real-Time Library of Drivers No Longer Recommended for Use

Note

The DAS1601/16 has an 8255 chip with 3 ports (A,B,C). Each port has a maximum of 8 digital I/O lines that can be configured as inputs or outputs.

Use a separate driver block for each port. By selecting the digital input driver block, the port is configured as input.

Scaling Input to Output

I/O Module Input	Block Output Data Type	Scaling
TTL	Double	TTL low = 0.0 TTL high = 1.0

Block Parameters

Channel vector

Enter numbers between 1 and 8 to select the digital input lines used with this port. This driver allows the selection of individual digital input lines in arbitrary order. The number of elements defines the number of digital lines used.

For example, to use all of the digital inputs for one port, enter

```
[1,2,3,4,5,6,7,8]
```

Number the lines beginning with 1 even if this board manufacturer starts numbering the lines with 0.

Port

From the list choose either A, B, or C. The I/O board has an 8255 chip with 3 ports. The port name defines which port of the 8255 chip is used for this driver block. Each port has a maximum of 8 digital lines that can be configured as inputs or outputs depending on which driver block is chosen. In each case, one block is required for each port.

Sample time

Enter the base sample time or a multiple of the base sample time (- 1 means sample time is inherited).

Base address

Enter the base address of the board. This entry must correspond to the DIP switch setting on the board. For example, if the DIP switch setting is 300 (hexadecimal), enter 0x300.

Measurement Computing CIO DAS1602/16 Digital Output

CIO DAS1602/16 Digital Output block (not recommended)

Library

Simulink Real-Time Library of Drivers No Longer Recommended for Use

Note

The DAS1602/16 has an 8255 chip with 3 ports (A,B,C). Each port has a maximum of 8 digital I/O lines that can be configured as inputs or outputs.

Use a separate driver block for each port. By selecting the digital output driver block, the port is configured as output.

Scaling Input to Output

I/O Module Output	Block Input Data Type	Scaling
TTL	Double	$< 0.5 = \text{TTL low}$ $\geq 0.5 = \text{TTL high}$

Block Parameters

Channel vector

Enter numbers between 1 and 8 to select the digital output lines used with this port. This driver allows the selection of individual digital output lines in arbitrary order. The number of elements defines the number of digital lines used.

For example, to use all of the digital outputs for one port, enter

[1,2,3,4,5,6,7,8]

Number the lines beginning with 1 even if this board manufacturer starts numbering the lines with 0.

Port

From the list choose either A, B, or C. The I/O board has an 8255 chip with 3 ports. The port name defines which port of the 8255 chip is used for this driver block. Each port has a maximum of 8 digital lines that can be configured as inputs or outputs depending on which driver block is chosen. In each case, one block is required for each port.

Reset vector

The reset vector controls the behavior of the channel at model termination. Enter a scalar or a vector that is the same length as the channel vector. If you specify a scalar value, that setting is replicated over the channel vector. If you specify a value of 1, the corresponding channel is reset to the value specified in the initial value vector. If you specify a value of 0, the channel remains at the last value attained while the model was running.

Initial value vector

The initial value vector contains the initial values (0 or 1) of the output channels. Enter a scalar or a vector that is the same length as the channel vector. If you enter a scalar, that value is replicated as the initial value over the channel vector. The channels are set to these initial values between the time the model is downloaded and the time it is started.

Sample time

Enter the base sample time or a multiple of the base sample time (-1 means sample time is inherited).

Base address

Enter the base address of the board. This entry must correspond to the DIP switch setting on the board. For example, if the DIP switch setting is 300 (hexadecimal), enter 0x300.

Measurement Computing CIO-DDA06 (/12)

Support for the MC CIO-DDA06 (/12) I/O board (not recommended)

Board

Measurement Computing CIO-DDA06 (/12)

General Description

The CIO-DDA06 (/12) is an I/O board with 6 analog output (D/A) channels (12-bit), and 24 digital I/O lines.

The Simulink Real-Time block library supports this board with these driver blocks:

- Measurement Computing CIO-DDA06 (/12) Analog Output (D/A)
- Measurement Computing CIO-DDA06 (/12) Digital Input
- Measurement Computing CIO-DDA06 (/12) Digital Output

Board Characteristics

Board name	CIO-DDA06 (/12)
Manufacturer	Measurement Computing
Bus type	ISA
Access method	I/O mapped
Multiple block instance support	Yes
Multiple board support	Yes

Measurement Computing CIO-DDA06 (/12) Analog Output (D/A)

CIO-DDA06 (/12) Analog Output block (not recommended)

Library

Simulink Real-Time Library of Drivers No Longer Recommended for Use

Scaling Input to Output

I/O Module Output	Block Input Data Type	Scaling
Volts	Double	1

Block Parameters

Channel vector

Enter numbers between 1 and 6. This driver allows the selection of individual D/A channels in arbitrary order. The number of elements defines the number of D/A channels used. For example, to use the first and second analog output (D/A) channels, enter

[1,2]

Number the channels beginning with 1 even if this board manufacturer starts numbering the channels with 0.

Range vector

Enter a range code for each of the channels in the channel vector. The range vector must be the same length as the channel vector. This board allows the range of each channel to be different.

The following table is a list of the ranges for this driver and the corresponding range codes.

Input Range (V)	Range Code
-10 to +10	-10
-5 to +5	-5
-2.5 to +2.5	-2.5
-1.67 to +1.67	-1.67
-0.625 to +0.625	-0.625
0 to +10	10
0 to +5	5
0 to +2.5	2.5
0 to +1.67	1.67

For example, if the first channel is -10 to +10 volts and the second channel is 0 to +5 volts, enter

[-10,5]

The range settings must correspond to the DIP switch settings on the board. The jumpers by the range DIP switches on the board must be in the XFER position. The wait state jumper must be in the off position.

Reset vector

The reset vector controls the behavior of the channel at model termination. Enter a scalar or a vector that is the same length as the channel vector. If you specify a scalar value, that setting is replicated over the channel vector. If you specify a value of 1, the corresponding channel is reset to the value specified in the initial value vector. If you specify a value of 0, the channel remains at the last value attained while the model was running.

Initial value vector

The initial value vector contains the initial voltage values for the output channels. Enter a scalar or a vector that is the same length as the channel vector. If you specify a scalar value, that value is replicated as the initial value over the channel vector. The channels are set to the initial values between the time the model is downloaded and the time it is started.

Sample time

Enter the base sample time or a multiple of the base sample time (- 1 means sample time is inherited).

Base address

Enter the base address of the board. This entry must correspond to the DIP switch setting on the board. For example, if the DIP switch setting is 300 (hexadecimal), enter 0x300.

Measurement Computing CIO-DDA06 (/12) Digital Input

CIO-DDA06 (/12) Digital Input (not recommended)

Library

Simulink Real-Time Library of Drivers No Longer Recommended for Use

Note

The CIO-DDA06 has an 8255 chip with 3 ports (A,B,C). Each port has a maximum of 8 digital I/O lines that can be configured as inputs or outputs.

Use a separate driver block for each port. By selecting the digital input driver block, the port is configured as input.

Scaling Input to Output

I/O Module Input	Block Output Data Type	Scaling
TTL	Double	TTL low = 0.0 TTL high = 1.0

Block Parameters

Channel vector

Enter numbers between 1 and 8 to select the digital input lines used with this port. This driver allows the selection of individual digital input lines in arbitrary order. The number of elements defines the number of digital lines used.

For example, to use all of the digital inputs for one port, enter

[1,2,3,4,5,6,7,8]

Number the lines beginning with 1 even if this board manufacturer starts numbering the lines with 0.

Port

From the list choose either A, B, or C. The I/O board has an 8255 chip with 3 ports. The port name defines which port of the 8255 chip is used for this driver block. Each port has a maximum of 8 digital lines that can be configured as inputs or outputs depending on which driver block is chosen. In each case, one block is required for each port.

Sample time

Enter the base sample time or a multiple of the base sample time (- 1 means sample time is inherited).

Base address

Enter the base address of the board. This entry must correspond to the DIP switch setting on the board. For example, if the DIP switch setting is 300 (hexadecimal), enter 0x300.

Measurement Computing CIO-DDA06 (/12) Digital Output

CIO-DDA06 (/12) Digital Output block (not recommended)

Library

Simulink Real-Time Library of Drivers No Longer Recommended for Use

Note

The CIO-DDA06 has an 8255 chip with 3 ports (A,B,C). Each port has a maximum of 8 digital I/O lines that can be configured as inputs or outputs.

Use a separate driver block for each port. By selecting the digital output driver block, the port is configured as output.

Scaling Input to Output

I/O Module Output	Block Input Data Type	Scaling
TTL	Double	$< 0.5 = \text{TTL low}$ $\geq 0.5 = \text{TTL high}$

Block Parameters

Channel vector

Enter numbers between 1 and 8 to select the digital output lines used with this port. This driver allows the selection of individual digital output lines in arbitrary order. The number of elements defines the number of digital lines used.

For example, to use all of the digital outputs for one port, enter

[1,2,3,4,5,6,7,8]

Number the lines beginning with 1 even if this board manufacturer starts numbering the lines with 0.

Port

From the list choose either A, B, or C. The I/O board has an 8255 chip with 3 ports. The port name defines which port of the 8255 chip is used for this driver block. Each port has a maximum of 8 digital lines that can be configured as inputs or outputs depending on which driver block is chosen. In each case, one block is required for each port.

Reset vector

The reset vector controls the behavior of the channel at model termination. Enter a scalar or a vector that is the same length as the channel vector. If you specify a scalar value, that setting is replicated over the channel vector. If you specify a value of 1, the corresponding channel is reset to the value specified in the initial value vector. If you specify a value of 0, the channel remains at the last value attained while the model was running.

Initial value vector

The initial value vector contains the initial values (0 or 1) of the output channels. Enter a scalar or a vector that is the same length as the channel vector. If you enter a scalar, that value is replicated as the initial value over the channel vector. The channels are set to these initial values between the time the model is downloaded and the time it is started.

Sample time

Enter the base sample time or a multiple of the base sample time (- 1 means sample time is inherited).

Base address

Enter the base address of the board. This entry must correspond to the DIP switch setting on the board. For example, if the DIP switch setting is 300 (hexadecimal), enter 0x300.

Measurement Computing CIO-DDA06/16

Support for the MC CIO-DDA06/16 I/O board (not recommended)

Board

Measurement Computing CIO-DDA06/16

General Description

The CIO-DDA06/16 is an I/O board with 6 analog output (D/A) channels (16-bit), and 24 digital I/O lines.

The Simulink Real-Time block library supports this board with these driver blocks:

- Measurement Computing CIO-DDA06/16 Analog Output (D/A)
- Measurement Computing CIO-DDA06/16 Digital Input
- Measurement Computing CIO-DDA06/16 Digital Output

Board Characteristics

Board name	CIO-DDA06/16
Manufacturer	Measurement Computing
Bus type	ISA
Access method	I/O mapped
Multiple block instance support	Yes
Multiple board support	Yes

Measurement Computing CIO-DDA06/16 Analog Output (D/A)

CIO-DDA06/16 Analog Output block (not recommended)

Library

Simulink Real-Time Library of Drivers No Longer Recommended for Use

Scaling Input to Output

I/O Module Output	Block Input Data Type	Scaling
Volts	Double	1

Block Parameters

Channel vector

Enter numbers between 1 and 6. This driver allows the selection of individual D/A channels in arbitrary order. The number of elements defines the number of D/A channels used. For example, to use the first and second analog output (D/A) channels, enter

[1,2]

Number the channels beginning with 1 even if this board manufacturer starts numbering the channels with 0.

Range vector

Enter a range code for each of the channels in the channel vector. The range vector must be the same length as the channel vector. This board allows the range of each channel to be different.

The following table is a list of the ranges for this driver and the corresponding range codes.

Input Range (V)	Range Code
-10 to +10	-10
-5 to +5	-5
-2.5 to +2.5	-2.5
-1.67 to +1.67	-1.67
-0.625 to +0.625	-0.625
0 to +10	10
0 to +5	5
0 to +2.5	2.5
0 to +1.67	1.67

For example, if the first channel is -10 to +10 volts and the second channel is 0 to +5 volts, enter

[-10,5]

The range settings must correspond to the DIP switch settings on the board. The jumpers by the range DIP switches on the board must be in the XFER position. The wait state jumper has to be in the off position.

Reset vector

The reset vector controls the behavior of the channel at model termination. Enter a scalar or a vector that is the same length as the channel vector. If you specify a scalar value, that setting is replicated over the channel vector. If you specify a value of 1, the corresponding channel is reset to the value specified in the initial value vector. If you specify a value of 0, the channel remains at the last value attained while the model was running.

Initial value vector

The initial value vector contains the initial voltage values for the output channels. Enter a scalar or a vector that is the same length as the channel vector. If you specify a scalar value, that value is replicated as the initial value over the channel vector. The channels are set to the initial values between the time the model is downloaded and the time it is started.

Sample time

Enter the base sample time or a multiple of the base sample time (- 1 means sample time is inherited).

Base address

Enter the base address of the board. This entry must correspond to the DIP switch setting on the board. For example, if the DIP switch setting is 300 (hexadecimal), enter 0x300.

Measurement Computing CIO-DDA06/16 Digital Input

CIO-DDA06/16 Digital Input block (not recommended)

Library

Simulink Real-Time Library of Drivers No Longer Recommended for Use

Note

The CIO-DDA06/16 has an 8255 chip with 3 ports (A,B,C). Each port has a maximum of 8 digital I/O lines that can be configured as inputs or outputs.

Use a separate driver block for each port. By selecting the digital input driver block, the port is configured as input.

Scaling Input to Output

I/O Module Input	Block Output Data Type	Scaling
TTL	Double	TTL low = 0.0 TTL high = 1.0

Block Parameters

Channel vector

Enter numbers between 1 and 8 to select the digital input lines used with this port. This driver allows the selection of individual digital input lines in arbitrary order. The number of elements defines the number of digital lines used.

For example, to use all of the digital inputs for one port, enter

```
[1,2,3,4,5,6,7,8]
```

Number the lines beginning with 1 even if this board manufacturer starts numbering the lines with 0.

Port

From the list choose either A, B, or C. The I/O board has an 8255 chip with 3 ports. The port name defines which port of the 8255 chip is used for this driver block. Each port has a maximum of 8 digital lines that can be configured as inputs or outputs depending on which driver block is chosen. In each case, one block is required for each port.

Sample time

Enter the base sample time or a multiple of the base sample time (- 1 means sample time is inherited).

Base address

Enter the base address of the board. This entry must correspond to the DIP switch setting on the board. For example, if the DIP switch setting is 300 (hexadecimal), enter 0x300.

Measurement Computing CIO-DDA06/16 Digital Output

CIO-DDA06/16 Digital Output block (not recommended)

Library

Simulink Real-Time Library of Drivers No Longer Recommended for Use

Note

The CIO-DDA06/16 has an 8255 chip with 3 ports (A,B,C). Each port has a maximum of 8 digital I/O lines that can be configured as inputs or outputs.

Use a separate driver block for each port. By selecting the digital output driver block, the port is configured as output.

Scaling Input to Output

I/O Module Output	Block Input Data Type	Scaling
TTL	Double	$< 0.5 = \text{TTL low}$ $\geq 0.5 = \text{TTL high}$

Block Parameters

Channel vector

Enter numbers between 1 and 8 to select the digital output lines used with this port. This driver allows the selection of individual digital output lines in arbitrary order. The number of elements defines the number of digital lines used.

For example, to use all of the digital outputs for one port, enter

[1,2,3,4,5,6,7,8]

Number the lines beginning with 1 even if this board manufacturer starts numbering the lines with 0.

Port

From the list choose either A, B, or C. The I/O board has an 8255 chip with 3 ports. The port name defines which port of the 8255 chip is used for this driver block. Each port has a maximum of 8 digital lines that can be configured as inputs or outputs depending on which driver block is chosen. In each case, one block is required for each port.

Reset vector

The reset vector controls the behavior of the channel at model termination. Enter a scalar or a vector that is the same length as the channel vector. If you specify a scalar value, that setting is replicated over the channel vector. If you specify a value of 1, the corresponding channel is reset to the value specified in the initial value vector. If you specify a value of 0, the channel remains at the last value attained while the model was running.

Initial value vector

The initial value vector contains the initial values (0 or 1) of the output channels. Enter a scalar or a vector that is the same length as the channel vector. If you enter a scalar, that value is replicated as the initial value over the channel vector. The channels are set to these initial values between the time the model is downloaded and the time it is started.

Sample time

Enter the base sample time or a multiple of the base sample time (-1 means sample time is inherited).

Base address

Enter the base address of the board. This entry must correspond to the DIP switch setting on the board. For example, if the DIP switch setting is 300 (hexadecimal), enter 0x300.

Measurement Computing CIO-DIO24

Support for the MC CIO-DIO24 I/O board (not recommended)

Board

Measurement Computing CIO-DIO24

General Description

The CIO-DIO24 is an I/O board with 24 digital I/O lines.

The Simulink Real-Time block library supports this board with these driver blocks:

- Measurement Computing CIO-DIO24 Digital Input
- Measurement Computing CIO-DIO24 Digital Output

Board Characteristics

Board name	CIO-DIO24
Manufacturer	Measurement Computing
Bus type	ISA
Access method	I/O mapped
Multiple block instance support	Yes
Multiple board support	Yes

Measurement Computing CIO-DIO24 Digital Input

CIO-DIO24 Digital Input block (not recommended)

Library

Simulink Real-Time Library of Drivers no longer in use

Note

The CIO-DIO24 has one 8255 chip with 3 ports (A,B,C). Each port has a maximum of 8 digital I/O lines that can be configured as inputs or outputs.

Use a separate driver block for each port. By selecting the digital input driver block, the port is configured as input.

Scaling Input to Output

I/O Module Input	Block Output Data Type	Scaling
TTL	Double	TTL low = 0.0 TTL high = 1.0

Block Parameters

Channel vector

Enter numbers between 1 and 8 to select the digital input lines used with this port. This driver allows the selection of individual digital input lines in arbitrary order. The number of elements defines the number of digital lines used.

For example, to use all of the digital inputs for one port, enter

```
[1,2,3,4,5,6,7,8]
```

Number the lines beginning with 1 even if this board manufacturer starts numbering the lines with 0.

Port

From the list choose either **A**, **B**, or **C**. The I/O board has an 8255 chip with 3 ports. The **Port** parameter defines which port of the 8255 chip is used for this driver block. Each port has a maximum of 8 digital lines that can be configured as inputs or outputs depending on which driver block is chosen. In each case, one block is required for each port.

Sample time

Enter the base sample time or a multiple of the base sample time (- 1 means sample time is inherited).

Base address

Enter the base address of the board. This entry must correspond to the DIP switch setting on the board. For example, if the DIP switch setting is 300 (hexadecimal), enter **0x300**.

Measurement Computing CIO-DIO24 Digital Output

CIO-DIO24 Digital Output block (not recommended)

Library

Simulink Real-Time Library of Drivers no longer in use

Note

The CIO-DIO24 has one 8255 chip with 3 ports (A,B,C). Each port has a maximum of 8 digital I/O lines that can be configured as inputs or outputs.

Use a separate driver block for each port. By selecting the digital output driver block, the port is configured as output.

Scaling Input to Output

I/O Module Output	Block Input Data Type	Scaling
TTL	Double	< 0.5 = TTL low ≥ 0.5 = TTL high

Block Parameters

Channel vector

Enter numbers between 1 and 8 to select the digital output lines used with this port. This driver allows the selection of individual digital output lines in arbitrary order. The number of elements defines the number of digital lines used.

For example, to use all of the digital outputs for one port, enter

```
[1,2,3,4,5,6,7,8]
```

Number the lines beginning with 1 even if this board manufacturer starts numbering the lines with 0.

Port

From the list choose either **A**, **B**, or **C**. The I/O board has an 8255 chip with 3 ports. The **Port** parameter defines which port of the 8255 chip is used for this driver block. Each port has a maximum of 8 digital lines that can be configured as inputs or outputs depending on which driver block is chosen. In each case, one block is required for each port.

Reset vector

The reset vector controls the behavior of the channel at model termination. Enter a scalar or a vector that is the same length as the channel vector. If you specify a scalar value, that setting is replicated over the channel vector. If you specify a value of 1, the corresponding channel is reset to the value specified in the initial value vector. If you specify a value of 0, the channel remains at the last value attained while the model was running.

Initial value vector

The initial value vector contains the initial values (0 or 1) of the output channels. Enter a scalar or a vector that is the same length as the channel vector. If you enter a scalar, that value is replicated as the initial value over the channel vector. The channels are set to these initial values between the time the model is downloaded and the time it is started.

Sample time

Enter the base sample time or a multiple of the base sample time (- 1 means sample time is inherited).

Base address

Enter the base address of the board. This entry must correspond to the DIP switch setting on the board. For example, if the DIP switch setting is 300 (hexadecimal), enter **0x300**.

Measurement Computing CIO-DIO24H

Support for the MC CIO-DIO24H I/O board (not recommended)

Board

Measurement Computing CIO-DIO24H

General Description

The CIO-DIO24H is an I/O board with 24 digital I/O lines.

The Simulink Real-Time block library supports this board with these driver blocks:

- Measurement Computing CIO-DIO24H Digital Input
- Measurement Computing CIO-DIO24H Digital Output

Board Characteristics

Board name	CIO-DIO24H
Manufacturer	Measurement Computing
Bus type	ISA
Access method	I/O mapped
Multiple block instance support	Yes
Multiple board support	Yes

Measurement Computing CIO-DIO24H Digital Input

CIO-DIO24H Digital Input (not recommended)

Library

Simulink Real-Time Library of Drivers No Longer Recommended for Use

Note

The CIO-DIO24H has one 8255 chip with 3 ports (A,B,C). Each port has a maximum of 8 digital I/O lines that can be configured as inputs or outputs.

Use a separate driver block for each port. By selecting the digital input driver block, the port is configured as input.

Scaling Input to Output

I/O Module Input	Block Output Data Type	Scaling
TTL	Double	TTL low = 0.0 TTL high = 1.0

Block Parameters

Channel vector

Enter numbers between 1 and 8 to select the digital input lines used with this port. This driver allows the selection of individual digital input lines in arbitrary order. The number of elements defines the number of digital lines used.

For example, to use all of the digital inputs for one port, enter

```
[1,2,3,4,5,6,7,8]
```

Number the lines beginning with 1 even if this board manufacturer starts numbering the lines with 0.

Port

From the list choose either **A**, **B**, or **C**. The I/O board has an 8255 chip with 3 ports. The **Port** parameter defines which port of the 8255 chip is used for this driver block. Each port has a maximum of 8 digital lines that can be configured as inputs or outputs depending on which driver block is chosen. In each case, one block is required for each port.

Sample time

Enter the base sample time or a multiple of the base sample time (- 1 means sample time is inherited).

Base address

Enter the base address of the board. This entry must correspond to the DIP switch setting on the board. For example, if the DIP switch setting is 300 (hexadecimal), enter **0x300**.

Measurement Computing CIO-DIO24H Digital Output

CIO-DIO24H Digital Output (not recommended)

Library

Simulink Real-Time Library of Drivers No Longer Recommended for Use

Note

The CIO-DIO24H has one 8255 chip with 3 ports (A,B,C). Each port has a maximum of 8 digital I/O lines that can be configured as inputs or outputs.

Use a separate driver block for each port. By selecting the digital output driver block, the port is configured as output.

Scaling Input to Output

I/O Module Output	Block Input Data Type	Scaling
TTL	Double	< 0.5 = TTL low ≥ 0.5 = TTL high

Block Parameters

Channel vector

Enter numbers between 1 and 8 to select the digital output lines used with this port. This driver allows the selection of individual digital output lines in arbitrary order. The number of elements defines the number of digital lines used.

For example, to use all of the digital outputs for one port, enter

```
[1,2,3,4,5,6,7,8]
```

Number the lines beginning with 1 even if this board manufacturer starts numbering the lines with 0.

Port

From the list choose either **A**, **B**, or **C**. The I/O board has an 8255 chip with 3 ports. The **Port** parameter defines which port of the 8255 chip is used for this driver block. Each port has a maximum of 8 digital lines that can be configured as inputs or outputs depending on which driver block is chosen. In each case, one block is required for each port.

Reset vector

The reset vector controls the behavior of the channel at model termination. Enter a scalar or a vector that is the same length as the channel vector. If you specify a scalar value, that setting is replicated over the channel vector. If you specify a value of 1, the corresponding channel is reset to the value specified in the initial value vector. If you specify a value of 0, the channel remains at the last value attained while the model was running.

Initial value vector

The initial value vector contains the initial values (0 or 1) of the output channels. Enter a scalar or a vector that is the same length as the channel vector. If you enter a scalar, that value is replicated as the initial value over the channel vector. The channels are set to these initial values between the time the model is downloaded and the time it is started.

Sample time

Enter the base sample time or a multiple of the base sample time (- 1 means sample time is inherited).

Base address

Enter the base address of the board. This entry must correspond to the DIP switch setting on the board. For example, if the DIP switch setting is 300 (hexadecimal), enter **0x300**.

Measurement Computing CIO-DIO48

Support for the MC CIO-DIO48 I/O board (not recommended)

Board

Measurement Computing CIO-DIO48

General Description

The CIO-DIO48 is an I/O board with 48 digital I/O lines.

The Simulink Real-Time block library supports this board with these driver blocks:

- Measurement Computing CIO-DIO48 Digital Input
- Measurement Computing CIO-DIO48 Digital Output

Board Characteristics

Board name	CIO-DIO48
Manufacturer	Measurement Computing
Bus type	ISA
Access method	I/O mapped
Multiple block instance support	Yes
Multiple board support	Yes

Measurement Computing CIO-DIO48 Digital Input

CIO-DIO48 Digital Input (not recommended)

Library

Simulink Real-Time Library of Drivers No Longer Recommended for Use

Note

The CIO-DIO48 has two 8255 chips (1,2). Each chip has three ports (A,B,C). Each port has a maximum of 8 digital I/O lines that can be configured as inputs or outputs.

Use a separate driver block for each port. By selecting the digital input driver block, the port is configured as input.

Scaling Input to Output

I/O Module Input	Block Output Data Type	Scaling
TTL	Double	TTL low = 0.0 TTL high = 1.0

Block Parameters

Channel vector

Enter numbers between 1 and 8 to select the digital input lines used with this port. This driver allows the selection of individual digital input lines in arbitrary order. The number of elements defines the number of digital lines used.

For example, to use all of the digital inputs for one port, enter

```
[1,2,3,4,5,6,7,8]
```

Number the lines beginning with 1 even if this board manufacturer starts numbering the lines with 0.

Port

From the list choose either **A**, **B**, or **C**. The I/O board has two 8255 chips with 3 ports. The **Port** parameter defines which port of the 8255 chip is used for this driver block. Each port has a maximum of 8 digital lines that can be configured as inputs or outputs depending on which driver block is chosen. In each case, one block is required for each port.

Chip

From the list choose **1** or **2**. The **Chip** parameter defines which of the two 8255 chips is used.

Sample time

Enter the base sample time or a multiple of the base sample time (- 1 means sample time is inherited).

Base address

Enter the base address of the board. This entry must correspond to the DIP switch setting on the board. For example, if the DIP switch setting is 300 (hexadecimal), enter **0x300**.

Measurement Computing CIO-DIO48 Digital Output

CIO-DIO48 Digital Output block (not recommended)

Library

Simulink Real-Time Library of Drivers No Longer Recommended for Use

Note

The CIO-DIO48 has two 8255 chips (1,2). Each chip has three ports (A,B,C). Each port has a maximum of 8 digital I/O lines that can be configured as inputs or outputs.

Use a separate driver block for each port. By selecting the digital output driver block, the port is configured as output.

Scaling Input to Output

I/O Module Output	Block Input Data Type	Scaling
TTL	Double	< 0.5 = TTL low ≥ 0.5 = TTL high

Block Parameters

Channel vector

Enter numbers between 1 and 8 to select the digital output lines used with this port. This driver allows the selection of individual digital output lines in arbitrary order. The number of elements defines the number of digital lines used.

For example, to use all of the digital outputs for one port, enter

```
[1,2,3,4,5,6,7,8]
```

Number the lines beginning with 1 even if this board manufacturer starts numbering the lines with 0.

Port

From the list choose either **A**, **B**, or **C**. The I/O board has two 8255 chips with 3 ports. The **Port** parameter defines which port of the 8255 chip is used for this driver block. Each port has a maximum of 8 digital lines that can be configured as inputs or outputs depending on which driver block is chosen. In each case, one block is required for each port.

Reset vector

The reset vector controls the behavior of the channel at model termination. Enter a scalar or a vector that is the same length as the channel vector. If you specify a scalar value, that setting is replicated over the channel vector. If you specify a value of 1, the corresponding channel is reset to the value specified in the initial value vector. If you specify a value of 0, the channel remains at the last value attained while the model was running.

Initial value vector

The initial value vector contains the initial values (0 or 1) of the output channels. Enter a scalar or a vector that is the same length as the channel vector. If you enter a scalar, that value is replicated as the initial value over the channel vector. The channels are set to these initial values between the time the model is downloaded and the time it is started.

Chip

From the list choose 1 or 2. The **Chip** parameter defines which of the two 8255 chips is used.

Sample time

Enter the base sample time or a multiple of the base sample time (-1 means sample time is inherited).

Base address

Enter the base address of the board. This entry must correspond to the DIP switch setting on the board. For example, if the DIP switch setting is 300 (hexadecimal), enter 0x300.

Measurement Computing CIO-DIO48H

Support for the MC CIO-DIO48H I/O board (not recommended)

Board

Measurement Computing CIO-DIO48H

General Description

The CIO-DIO48H is an I/O board with 48 digital I/O lines.

The Simulink Real-Time block library supports this board with these driver blocks:

- Measurement Computing CIO-DIO48H Digital Input
- Measurement Computing CIO-DIO48H Digital Output

Board Characteristics

Board name	CIO-DIO48H
Manufacturer	Measurement Computing
Bus type	ISA
Access method	I/O mapped
Multiple block instance support	Yes
Multiple board support	Yes

Measurement Computing CIO-DIO48H Digital Input

CIO-DIO48H Digital Input block (not recommended)

Library

Simulink Real-Time Library of Drivers No Longer Recommended for Use

General Description

The CIO-DIO48H has two 8255 chips (1,2). Each chip has three ports (A,B,C). Each port has a maximum of 8 digital I/O lines that can be configured as inputs or outputs.

Use a separate driver block for each port. By selecting the digital input driver block, the port is configured as input.

Scaling Input to Output

I/O Module Input	Block Output Data Type	Scaling
TTL	Double	TTL low = 0.0 TTL high = 1.0

Block Parameters

Channel vector

Enter numbers between 1 and 8 to select the digital input lines used with this port. This driver allows the selection of individual digital input lines in arbitrary order. The number of elements defines the number of digital lines used.

For example, to use all of the digital inputs for one port, enter

```
[1,2,3,4,5,6,7,8]
```

Number the lines beginning with 1 even if this board manufacturer starts numbering the lines with 0.

Port

From the list choose either **A**, **B**, or **C**. The I/O board has two 8255 chips with 3 ports. The **Port** parameter defines which port of the 8255 chip is used for this driver block. Each port has a maximum of 8 digital lines that can be configured as inputs or outputs depending on which driver block is chosen. In each case, one block is required for each port.

Chip

From the list choose **1** or **2**. The **Chip** parameter defines which of the two 8255 chips is used.

Sample time

Enter the base sample time or a multiple of the base sample time (- 1 means sample time is inherited).

Base address

Enter the base address of the board. This entry must correspond to the DIP switch setting on the board. For example, if the DIP switch setting is 300 (hexadecimal), enter **0x300**.

Measurement Computing CIO-DIO48H Digital Output

CIO-DIO48H Digital Output block (not recommended)

Library

Simulink Real-Time Library of Drivers No Longer Recommended for Use

Note

The CIO-DIO48H has two 8255 chips (1,2). Each chip has three ports (A,B,C). Each port has a maximum of 8 digital I/O lines that can be configured as inputs or outputs.

Use a separate driver block for each port. By selecting the digital output driver block, the port is configured as output.

Scaling Input to Output

I/O Module Output	Block Input Data Type	Scaling
TTL	Double	< 0.5 = TTL low ≥ 0.5 = TTL high

Block Parameters

Channel vector

Enter numbers between 1 and 8 to select the digital output lines used with this port. This driver allows the selection of individual digital output lines in arbitrary order. The number of elements defines the number of digital lines used.

For example, to use all of the digital outputs for one port, enter

```
[1,2,3,4,5,6,7,8]
```

Number the lines beginning with 1 even if this board manufacturer starts numbering the lines with 0.

Port

From the list choose either **A**, **B**, or **C**. The I/O board has two 8255 chips with 3 ports. The **Port** parameter defines which port of the 8255 chip is used for this driver block. Each port has a maximum of 8 digital lines that can be configured as inputs or outputs depending on which driver block is chosen. In each case, one block is required for each port.

Reset vector

The reset vector controls the behavior of the channel at model termination. Enter a scalar or a vector that is the same length as the channel vector. If you specify a scalar value, that setting is replicated over the channel vector. If you specify a value of 1, the corresponding channel is reset to the value specified in the initial value vector. If you specify a value of 0, the channel remains at the last value attained while the model was running.

Initial value vector

The initial value vector contains the initial values (0 or 1) of the output channels. Enter a scalar or a vector that is the same length as the channel vector. If you enter a scalar, that value is replicated as the initial value over the channel vector. The channels are set to these initial values between the time the model is downloaded and the time it is started.

Chip

From the list choose 1 or 2. The **Chip** parameter defines which of the two 8255 chips is used.

Sample time

Enter the base sample time or a multiple of the base sample time (-1 means sample time is inherited).

Base address

Enter the base address of the board. This entry must correspond to the DIP switch setting on the board. For example, if the DIP switch setting is 300 (hexadecimal), enter 0x300.

Measurement Computing CIO-DIO96

Support for the MC CIO-DIO96 I/O board (not recommended)

Board

Measurement Computing CIO-DIO96

General Description

The CIO-DIO96 is an I/O board with 96 digital I/O lines.

The Simulink Real-Time block library supports this board with these driver blocks:

- Measurement Computing CIO-DIO96 Digital Input
- Measurement Computing CIO-DIO96 Digital Output

Board Characteristics

Board name	CIO-DIO96
Manufacturer	Measurement Computing
Bus type	ISA
Access method	I/O mapped
Multiple block instance support	Yes
Multiple board support	Yes

Measurement Computing CIO-DIO96 Digital Input

CIO-DIO96 Digital Input block (not recommended)

Library

Simulink Real-Time Library of Drivers No Longer Recommended for Use

Note

The CIO-DIO96 has four 8255 chips (1,2,3,4). Each chip has three ports (A,B,C). Each port has a maximum of 8 digital I/O lines that can be configured as inputs or outputs.

Use a separate driver block for each port. By selecting the digital input driver block, the port is configured as input.

Scaling Input to Output

I/O Module Input	Block Output Data Type	Scaling
TTL	Double	TTL low = 0.0 TTL high = 1.0

Block Parameters

Channel vector

Enter numbers between 1 and 8 to select the digital input lines used with this port. This driver allows the selection of individual digital input lines in arbitrary order. The number of elements defines the number of digital lines used.

For example, to use all of the digital inputs for one port, enter

```
[1,2,3,4,5,6,7,8]
```

Number the lines beginning with 1 even if this board manufacturer starts numbering the lines with 0.

Port

From the list choose either **A**, **B**, or **C**. The I/O board has two 8255 chips with 3 ports. The **Port** parameter defines which port of the 8255 chip is used for this driver block. Each port has a maximum of 8 digital lines that can be configured as inputs or outputs depending on which driver block is chosen. In each case, one block is required for each port.

Chip

From the list choose **1**, **2**, **3**, or **4**. The **Chip** parameter defines which of the four 8255 chips is used.

Sample time

Enter the base sample time or a multiple of the base sample time (- 1 means sample time is inherited).

Base address

Enter the base address of the board. This entry must correspond to the DIP switch setting on the board. For example, if the DIP switch setting is 300 (hexadecimal), enter **0x300**.

Measurement Computing CIO-DIO96 Digital Output

CIO-DIO96 Digital Output block (not recommended)

Library

Simulink Real-Time Library of Drivers No Longer Recommended for Use

Note

The CIO-DIO96 has four 8255 chips (1,2,3,4). Each chip has three ports (A,B,C). Each port has a maximum of 8 digital I/O lines that can be configured as inputs or outputs.

Use a separate driver block for each port. By selecting the digital output driver block, the port is configured as output.

Scaling Input to Output

I/O Module Output	Block Input Data Type	Scaling
TTL	Double	< 0.5 = TTL low ≥ 0.5 = TTL high

Block Parameters

Channel vector

Enter numbers between 1 and 8 to select the digital output lines used with this port. This driver allows the selection of individual digital output lines in arbitrary order. The number of elements defines the number of digital lines used.

For example, to use all of the digital outputs for one port, enter

```
[1,2,3,4,5,6,7,8]
```

Number the lines beginning with 1 even if this board manufacturer starts numbering the lines with 0.

Port

From the list choose either **A**, **B**, or **C**. The I/O board has two 8255 chips with 3 ports. The **Port** parameter defines which port of the 8255 chip is used for this driver block. Each port has a maximum of 8 digital lines that can be configured as inputs or outputs depending on which driver block is chosen. In each case, one block is required for each port.

Reset vector

The reset vector controls the behavior of the channel at model termination. Enter a scalar or a vector that is the same length as the channel vector. If you specify a scalar value, that setting is replicated over the channel vector. If you specify a value of 1, the corresponding channel is reset to the value specified in the initial value vector. If you specify a value of 0, the channel remains at the last value attained while the model was running.

Initial value vector

The initial value vector contains the initial values (0 or 1) of the output channels. Enter a scalar or a vector that is the same length as the channel vector. If you enter a scalar, that value is replicated as the initial value over the channel vector. The channels are set to these initial values between the time the model is downloaded and the time it is started.

Chip

From the list choose 1, 2, 3, or 4. The **Chip** parameter defines which of the four 8255 chips is used.

Sample time

Enter the base sample time or a multiple of the base sample time (-1 means sample time is inherited).

Base address

Enter the base address of the board. This entry must correspond to the DIP switch setting on the board. For example, if the DIP switch setting is 300 (hexadecimal), enter 0x300.

Measurement Computing CIO-DIO192

Support for the MC CIO-DIO192 I/O board (not recommended)

Board

Measurement Computing CIO-DIO192

General Description

The CIO - DIO192 is an I/O board with 192 digital I/O lines.

The Simulink Real-Time block library supports this board with these driver blocks:

- Measurement Computing CIO-DIO192 Digital Input
- Measurement Computing CIO-DIO192 Digital Output

Board Characteristics

Board name	CIO-DIO192
Manufacturer	Measurement Computing
Bus type	ISA
Access method	I/O mapped
Multiple block instance support	Yes
Multiple board support	Yes

Measurement Computing CIO-DIO192 Digital Input

CIO-DIO192 Digital Input block (not recommended)

Library

Simulink Real-Time Library of Drivers No Longer Recommended for Use

Note

The CIO-DIO96 has eight 8255 chips (1,2,3,4,5,6,7,8). Each chip has three ports (A,B,C). Each port has a maximum of 8 digital I/O lines that can be configured as inputs or outputs.

Use a separate driver block for each port. By selecting the digital input driver block, the port is configured as input.

Scaling Input to Output

I/O Module Input	Block Output Data Type	Scaling
TTL	Double	TTL low = 0.0 TTL high = 1.0

Block Parameters

Channel vector

Enter numbers between 1 and 8 to select the digital input lines used with this port. This driver allows the selection of individual digital input lines in arbitrary order. The number of elements defines the number of digital lines used.

For example, to use all of the digital inputs for one port, enter

```
[1,2,3,4,5,6,7,8]
```

Number the lines beginning with 1 even if this board manufacturer starts numbering the lines with 0.

Port

From the list choose either **A**, **B**, or **C**. The I/O board has two 8255 chips with 3 ports. The **Port** parameter defines which port of the 8255 chip is used for this driver block. Each port has a maximum of 8 digital lines that can be configured as inputs or outputs depending on which driver block is chosen. In each case, one block is required for each port.

Chip

From the list choose **1**, **2**, **3**, **4**, **5**, **6**, **7**, or **8**. The **Chip** parameter defines which of the eight 8255 chips is used.

Sample time

Enter the base sample time or a multiple of the base sample time (- 1 means sample time is inherited).

Base address

Enter the base address of the board. This entry must correspond to the DIP switch setting on the board. For example, if the DIP switch setting is 300 (hexadecimal), enter **0x300**.

Measurement Computing CIO-DIO192 Digital Output

CIO-DIO192 Digital Output block (not recommended)

Library

Simulink Real-Time Library of Drivers No Longer Recommended for Use

Note

The CIO-DIO192 has eight 8255 chips (1,2,3,4,5,6,7,8). Each chip has three ports (A,B,C). Each port has a maximum of 8 digital I/O lines that can be configured as inputs or outputs.

Use a separate driver block for each port. By selecting the digital output driver block, the port is configured as output.

Scaling Input to Output

I/O Module Output	Block Input Data Type	Scaling
TTL	Double	$< 0.5 = \text{TTL low}$ $\geq 0.5 = \text{TTL high}$

Block Parameters

Channel vector

Enter numbers between 1 and 8 to select the digital output lines used with this port. This driver allows the selection of individual digital output lines in arbitrary order. The number of elements defines the number of digital lines used.

For example, to use all of the digital outputs for one port, enter

```
[1,2,3,4,5,6,7,8]
```

Number the lines beginning with 1 even if this board manufacturer starts numbering the lines with 0.

Port

From the list choose either **A**, **B**, or **C**. The I/O board has two 8255 chips with 3 ports. The **Port** parameter defines which port of the 8255 chip is used for this driver block. Each port has a maximum of 8 digital lines that can be configured as inputs or outputs depending on which driver block is chosen. In each case, one block is required for each port.

Reset vector

The reset vector controls the behavior of the channel at model termination. Enter a scalar or a vector that is the same length as the channel vector. If you specify a scalar value, that setting is replicated over the channel vector. If you specify a value of 1, the corresponding channel is reset to the value specified in the initial value vector. If you specify a value of 0, the channel remains at the last value attained while the model was running.

Initial value vector

The initial value vector contains the initial values (0 or 1) of the output channels. Enter a scalar or a vector that is the same length as the channel vector. If you enter a scalar, that value is replicated as the initial value over the channel vector. The channels are set to these initial values between the time the model is downloaded and the time it is started.

Chip

From the list choose 1, 2, 3, 4, 5, 6, 7, or 8. The **Chip** parameter defines which of the eight 8255 chips is used.

Sample time

Enter the base sample time or a multiple of the base sample time (-1 means sample time is inherited).

Base address

Enter the base address of the board. This entry must correspond to the DIP switch setting on the board. For example, if the DIP switch setting is 300 (hexadecimal), enter **0x300**.

Measurement Computing CIO-DO24DD

Support for the MC CIO-DO24DD I/O board (not recommended)

Board

Measurement Computing CIO-DO24DD

General Description

The CIO-DO24DD is an I/O board with 24 open-collector digital output lines.

Simulink Real-Time supports this board with this driver block:

- Measurement Computing CIO-DO24DD Digital Output

Board Characteristics

Board name	CIO-DO24DD
Manufacturer	Measurement Computing
Bus type	ISA
Access method	I/O mapped
Multiple block instance support	Yes
Multiple board support	Yes

Measurement Computing CIO-DO24DD Digital Output

CIO-DO24DD Digital Output block (not recommended)

Library

Simulink Real-Time Library of Drivers No Longer Recommended for Use

Note

The CIO-DIO24DD has one 8255 chip with 3 ports (A,B,C). Each port has a maximum of 8 digital I/O lines that are configured as outputs.

Use a separate driver block for each port. By selecting the digital output driver block, the port is configured as output.

Scaling Input to Output

I/O Module Output	Block Input Data Type	Scaling
TTL	Double	$< 0.5 = \text{TTL low}$ $\geq 0.5 = \text{TTL high}$

Block Parameters

Channel vector

Enter numbers between 1 and 8 to select the digital output lines used with this port. This driver allows the selection of individual digital output lines in arbitrary order. The number of elements defines the number of digital lines used.

For example, to use all of the digital outputs for one port, enter

[1,2,3,4,5,6,7,8]

Number the lines beginning with 1 even if this board manufacturer starts numbering the lines with 0.

Port

From the list choose either A, B, or C. The I/O board has an 8255 chip with 3 ports. The **Port** parameter defines which port of the 8255 chip is used for this driver block. Each port has a maximum of 8 digital lines that can be configured as inputs or outputs depending on which driver block is chosen. In each case, one block is required for each port.

Reset vector

The reset vector controls the behavior of the channel at model termination. Enter a scalar or a vector that is the same length as the channel vector. If you specify a scalar value, that setting is replicated over the channel vector. If you specify a value of 1, the corresponding channel is reset to the value specified in the initial value vector. If you specify a value of 0, the channel remains at the last value attained while the model was running.

Initial value vector

The initial value vector contains the initial values (0 or 1) of the output channels. Enter a scalar or a vector that is the same length as the channel vector. If you enter a scalar, that value is replicated as the initial value over the channel vector. The channels are set to these initial values between the time the model is downloaded and the time it is started.

Sample time

Enter the base sample time or a multiple of the base sample time (- 1 means sample time is inherited).

Base address

Enter the base address of the board. This entry must correspond to the DIP switch setting on the board. For example, if the DIP switch setting is 300 (hexadecimal), enter 0x300.

Measurement Computing CIO-PDISO16

Support for the MC CIO-PDISO16 I/O board (not recommended)

Board

Measurement Computing CIO-PDISO16

General Description

The CIO-PDISO16 is an I/O board with 16 isolated digital input lines and 16 relay driven digital output lines.

The Simulink Real-Time block library supports this board with these driver blocks:

- Measurement Computing CIO-PDISO16 Digital Input
- Measurement Computing CIO-PDISO16 Digital Output

Note: The Simulink Real-Time software does not support the 16 relays on this board.

Board Characteristics

Board name	CIO-PDISO16
Manufacturer	Measurement Computing
Bus type	ISA
Access method	I/O mapped
Multiple block instance support	Yes
Multiple board support	Yes

Measurement Computing CIO-PDISO16 Digital Input

CIO-PDISO16 Digital Input block (not recommended)

Library

Simulink Real-Time Library of Drivers No Longer Recommended for Use

Note

The CIO-PDISO16 has two independent connectors. Each connector has 8 digital input lines.

Use a separate driver block for each connector.

Scaling Input to Output

I/O Module Input	Block Output Data Type	Scaling
5 to 24 volts DC/AC	Double	~0 volts = 0.0 5 to 24 volts = 1.0

Block Parameters

Number of Channels

Enter a number between 1 and 8 to select the number of digital input lines used with this connector. This driver does not allow the selection of individual digital input lines.

Section(Connector)

From the list, choose either 1 (nearest to backplate) or 2 (farthest from backplate) to select the connector used.

Sample time

Enter the base sample time or a multiple of the base sample time (-1 means sample time is inherited).

Base address

Enter the base address of the board. It is important that this entry corresponds to the DIP switch settings on the board. For example, if the base address is 300 (hexadecimal), enter

0x300

The Wait-State jumper has to be in the off position.

The remaining switch and jumper settings do not influence the running of the Simulink Real-Time software.

Measurement Computing CIO-PDISO16 Digital Output

CIO-PDISO16 Digital Output block (not recommended)

Library

Simulink Real-Time Library of Drivers No Longer Recommended for Use

Note

The CIO-PDISO16 has two independent connectors. Each connector has 8 relay driven digital input lines.

Use a separate driver block for each connector.

Scaling Input to Output

I/O Module Output	Block Input Data Type	Scaling
relay	Double	< 0.5 = Relay open ≥ 0.5 = Relay closed

Block Parameters

Number of Channels

Enter a number between 1 and 8 to select the number of digital output lines used with this connector. This driver does not allow the selection of individual digital output lines.

Section(Connector)

From the list, choose either 1 (nearest to backplate) or 2 (farthest from backplate) to select the connector used.

Sample time

Enter the base sample time or a multiple of the base sample time (- 1 means sample time is inherited).

Base address

Enter the base address of the board. It is important that this entry corresponds to the DIP switch settings on the board. For example, if the base address is 300 (hexadecimal), enter

0x300

The Wait-State jumper has to be in the off position.

The remaining switch and jumper settings do not influence the running of the Simulink Real-Time software.

Measurement Computing CIO-QUAD02

Support for the MC CIO-QUAD02 counting board (not recommended)

Board

Measurement Computing CIO-QUAD02

General Description

The CIO-QUAD02 is a 24-bit counting board with 2 channels. This board typically connects to incremental encoders. Incremental encoders convert physical motion into electrical pulses that can be used to determine velocity, direction, and distance.

The Simulink Real-Time block library supports this board with this driver block:

- Measurement Computing CIO-QUAD02 Incremental Encoder

Board Characteristics

Board name	CIO-QUAD02
Manufacturer	Measurement Computing
Bus type	ISA
Access method	I/O mapped
Multiple block instance support	Yes
Multiple board support	Yes

Measurement Computing CIO-QUAD02 Incremental Encoder

CIO-QUAD02 Incremental Encoder block (not recommended)

Library

Simulink Real-Time Library of Drivers No Longer Recommended for Use

Note

This driver block has one block output: **Count**.

The raw count value is a 24-bit integer that is converted to a double precision float output from the block. The 24-bit value can be interpreted in different ways (see **Count Range**).

In this section, the clockwise direction is the direction in which the counter increments. The counterclockwise direction is the direction in which the counter decrements. Note that the counter direction depends on the encoder manufacturer and the way in which the encoder is installed.

Block Parameters

Channel

From the list, choose 1, 2, 3, or 4. This parameter specifies the channel you use for this block. For the same board (same base address) two blocks cannot have the same channel number.

Index input resets counter

Choose this check box to control the behavior when the index is reached. For example, a rotary encoder typically reaches the index at one particular position in its range of motion. Setting this check box to reset the count value allows you to get a repeatable position from an encoder. When the encoder reaches the index (asserts the index), the counter value is set to the value given in the **Count Limit or Reset Value** field.

Index Polarity

From the list, select the index pulse slope that the board should detect. Select **Positive Index** for a positive slope; select **Negative Index** for a negative slope.

Counting Mode

From the list, select a counting mode (**Normal**, **Range Limit**, **Non-recycle**, or **Modulo-N**). The output of the block depends on both the setting of **Index input resets counter** and on the counting mode as described in the following table.

Counting Mode	Index input resets counter Selected	Index input resets counter Deselected
Normal	<p>Upon model start, the output count is initialized to Count Limit or Reset Value. The output count increments or decrements one full revolution from the Count Limit or Reset Value. The output count is reset to this value each time the index is reached.</p> <p>For example, if Index input resets counter is selected, and a rotary encoder has 1024 counts per revolution, and a Count Limit or Reset Value of 5000, a full clockwise revolution of the encoder increments the counter to 6023, at which the index is reached. The counter then resets to 5000.</p>	<p>Upon model start, the counter is initialized to 0. The counter then increments or decrements until it either overflows or underflows. For a rotary encoder, the number of revolutions is the number of output counts divided by the number of counts per revolution. The resulting integer is the number of revolutions; the fractional part can be converted to an angle.</p>
Range Limit	<p>Upon model start, the counter increments or decrements until it reaches the count limit Count Limit or Reset Value. If the clock motion is clockwise, the counter stays at Count Limit or Reset Value once it reaches that value. If the clock motion is counterclockwise, the counter decrements one revolution then resets to Count Limit or Reset Value.</p>	<p>Upon model start, the counter is initialized to 0. In the clockwise direction, the counter increments until it saturates at Count Limit or Reset Value. In the counterclockwise direction, the counter decrements until it saturates at 0.</p> <p>You can use this setting to set a repeatable 0 when there is a mechanical stop. At model start, the count is initialized to 0. The machine then shifts to the negative direction stop. At that point, the encoder reports 0 at the stop</p>

Counting Mode	Index input resets counter Selected	Index input resets counter Deselected
		and the other positions will be positive and repeatable.
Non-recycle	Upon model start, the counter is initialized to Count Limit or Reset Value . With counterclockwise rotation, the counter decrements and saturates at 0. If the encoder reaches the index before the counter saturates at 0, the counter resets to Count Limit or Reset Value . With clockwise rotation, the counter increments until the encoder reaches the index. When the encoder reaches the index, the counter resets to Count Limit or Reset Value . You can use this setting to place 0 at the first index inside a mechanical limit.	Upon model start, the counter decrements until it reaches either 0 or Count Limit or Reset Value . The counter restarts when a reset event occurs, such as the index has caused a reset. The behavior of this option is undefined.
Modulo-N	The behavior of this option is undefined.	Upon model start, the counter is initialized to 0. In the clockwise direction, the counter increments to Count Limit or Reset Value , then resets to 0 and repeats. When the counter decrements, it counts to 0, then resets to the Count Limit or Reset Value and continues to decrement. You can use this setting to repeat intervals that do not match the distance between indexes (resulting, for example, from gear ratios).

Counting Mode	Index input resets counter Selected	Index input resets counter Deselected
Non-recycle	Upon model start, the counter is initialized to Count Limit or Reset Value . With counterclockwise rotation, the counter decrements and saturates at 0. If the encoder reaches the index before the counter saturates at 0, the counter resets to Count Limit or Reset Value . With clockwise rotation, the counter increments until the encoder reaches the index. When the encoder reaches the index, the counter resets to Count Limit or Reset Value . You can use this setting to place 0 at the first index inside a mechanical limit.	The behavior of this option is undefined.

Count Limit or Reset Value

The preset register (PR) on the counter chip is a 24-bit quantity. The counter uses this value as a limit for the **Range Limit**, **Non-recycle**, and **Modulo-N** counting modes.

When **Index input resets counter** is selected, this value acts as both the initial value at model start and the value that an index resets the count to.

You can enter negative limit values, but the counter treats them as large positive values. For example, a limit of -1 results in the **Modulo-N** range from 0 to $2^{24} - 1$, not from -1 to 0.

Count Range

From the list, choose $0 \dots 2^{24} - 1$ or $-2^{23} \dots +2^{23} - 1$. The counter uses a 24-bit accumulator which overflows from $2^{24} - 1$ to 0. This same overflow can be interpreted as the transition from -1 to 0. Selecting the unipolar range 0 to $2^{24} - 1$ puts the discontinuity in counts at 0. Selecting the bipolar range of $(-2)^{23}$ to $2^{23} - 1$ puts the discontinuity far away from 0. The bipolar range is achieved by sign extending the 24-bit count to 32 bits before converting to double.

Count Speed

From the list, choose non-quadrature, 1X, 2X, or 4X:

- **non-quadrature** — Counts the rising edges of the A input, losing direction information in the process. The presence of a quadrature signal on the B input might cause undefined results. You should disconnect the B and index inputs.
- **1X** — Counts up or down once per complete cycle of the quadrature signal.
- **2X** — Counts up or down twice per complete cycle of the quadrature signal.
- **4X** — Counts up or down four times per complete cycle of the quadrature signal.

Filter prescale factor

Enter a base prescale factor for digital filtering. This filter helps eliminate high frequency noise. Enter a value from 0 to ff in hexadecimal (0 to 256 in decimal). For example, for a prescale factor value of ff in hexadecimal, enter

0xff

Sample Time

Enter a base sample time or a multiple of the base sample time. The sample time indicates the update rate of registration on the input (Duty Cycle). Enter -1 to inherit the model sample time from another block. The sample time is in seconds.

Base address

Enter the base address of the board. This entry must correspond to the DIP switch setting on the board. For example, if the DIP switch setting is 300 (hexadecimal), enter 0x300.

Measurement Computing CIO-QUAD04

Support for the MC CIO-QUAD04 counting board (not recommended)

Board

Measurement Computing CIO-QUAD04

General Description

The CIO-QUAD04 is a 24-bit counting board with 4 channels. This board typically connects to incremental encoders. Incremental encoders convert physical motion into electrical pulses that can be used to determine velocity, direction, and distance.

The Simulink Real-Time block library supports this board with this driver block:

- Measurement Computing CIO-QUAD04 Incremental Encoder

There is a physical limitation with the CIO-Quad04 boards in the way that they handle unconnected inputs. Even with the **Index input resets counter** check box disabled, noise on the index input line might cause the counter chip on the board to latch a value that differs from the actual value by a multiple of 256. The frequency of occurrence of the bad reads depends on the count frequency coming from the encoder. High count rates result in more bad reads.

To work around this issue, try the following:

- 1 If the index signal from an encoder is not being used, connect the index inputs.
- 2 Connect the index+ input to +5 volts.
- 3 Connect the index- input to ground.

These connections should be made as close to the board as possible to minimize crosstalk at high count frequencies.

Board Characteristics

Board name

CIO-QUAD04

Manufacturer	Measurement Computing
Bus type	ISA
Access method	I/O mapped
Multiple block instance support	Yes
Multiple board support	Yes

Measurement Computing CIO-QUAD04 Incremental Encoder

CIO-QUAD04 Incremental Encoder block (not recommended)

Library

Simulink Real-Time Library of Drivers No Longer Recommended for Use

Note

This driver block has one block output: **Count**.

The raw count value is a 24-bit integer that is converted to a double precision float output from the block. The 24-bit value can be interpreted in different ways (see **Count Range**).

In this section, the clockwise direction is the direction in which the counter increments. The counterclockwise direction is the direction in which the counter decrements. Note that the counter direction depends on the encoder manufacturer and the way in which the encoder is installed.

Block Parameters

Channel

From the list, choose 1, 2, 3, or 4. This parameter specifies the channel you use for this block. For the same board (same base address) two blocks cannot have the same channel number.

Index input resets counter

Choose this check box to control the behavior when the index is reached. For example, a rotary encoder typically reaches the index at one particular position in its range of motion. Setting this check box to reset the count value allows you to get a repeatable position from an encoder. When the encoder reaches the index (asserts

the index), the counter value is set to the value given in the **Count Limit or Reset Value** field.

Index Polarity

From the list, select the index pulse slope that the board should detect. Select **Positive Index** for a positive slope; select **Negative Index** for a negative slope.

Counting Mode

From the list, select a counting mode (**Normal**, **Range Limit**, **Non-recycle**, or **Modulo-N**). The output of the block depends on both the setting of **Index input resets counter** and on the counting mode as described in the following table.

Counting Mode	Index input resets counter Selected	Index input resets counter Deselected
Normal	<p>Upon model start, the output count is initialized to Count Limit or Reset Value. The output count increments or decrements one full revolution from the Count Limit or Reset Value. The output count is reset to this value each time the index is reached.</p> <p>For example, if Index input resets counter is selected, and a rotary encoder has 1024 counts per revolution, and a Count Limit or Reset Value of 5000, a full clockwise revolution of the encoder increments the counter to 6023, at which the index is reached. The counter then resets to 5000.</p>	<p>Upon model start, the counter is initialized to 0. The counter then increments or decrements until it either overflows or underflows. For a rotary encoder, the number of revolutions is the number of output counts divided by the number of counts per revolution. The resulting integer is the number of revolutions; the fractional part can be converted to an angle.</p>
Range Limit	<p>Upon model start, the counter increments or decrements until it reaches the count limit Count Limit or Reset Value. If the clock motion is clockwise, the counter stays at Count Limit or Reset Value once it reaches that value. If the clock motion is counterclockwise, the counter decrements one revolution then resets to Count Limit or Reset Value.</p>	<p>Upon model start, the counter is initialized to 0. In the clockwise direction, the counter increments until it saturates at Count Limit or Reset Value. In the counterclockwise direction, the counter decrements until it saturates at 0.</p> <p>You can use this setting to set a repeatable 0 when there is a mechanical stop. At model start,</p>

Counting Mode	Index input resets counter Selected	Index input resets counter Deselected
		the count is initialized to 0. The machine then shifts to the negative direction stop. At that point, the encoder reports 0 at the stop and the other positions will be positive and repeatable.
Non-recycle	Upon model start, the counter is initialized to Count Limit or Reset Value . With counterclockwise rotation, the counter decrements and saturates at 0. If the encoder reaches the index before the counter saturates at 0, the counter resets to Count Limit or Reset Value . With clockwise rotation, the counter increments until the encoder reaches the index. When the encoder reaches the index, the counter resets to Count Limit or Reset Value . You can use this setting to place 0 at the first index inside a mechanical limit.	The behavior of this option is undefined.
Modulo-N	The behavior of this option is undefined.	Upon model start, the counter is initialized to 0. In the clockwise direction, the counter increments to Count Limit or Reset Value , then resets to 0 and repeats. When the counter decrements, it counts to 0, then resets to Count Limit or Reset Value and continues to decrement. You can use this setting to repeat intervals that do not match the distance between indexes (resulting, for example, from gear ratios).

Count Limit or Reset Value

The preset register (PR) on the counter chip is a 24-bit quantity. The counter uses this value as a limit for the **Range Limit**, **Non-recycle**, and **Modulo-N** counting modes.

When **Index input resets counter** is selected, this value acts as both the initial value at model start and the value that an index resets the count to.

You can enter negative limit values, but the counter treats them as large positive values. For example, a limit of -1 results in the **Modulo-N** range from 0 to $2^{24} - 1$, not from -1 to 0.

Count Range

From the list, choose $0 \dots 2^{24} - 1$ or $-2^{23} \dots +2^{23} - 1$. The counter uses a 24-bit accumulator which overflows from $2^{24} - 1$ to 0. This same overflow can be interpreted as the transition from -1 to 0. Selecting the unipolar range 0 to $2^{24} - 1$ puts the discontinuity in counts at 0. Selecting the bipolar range of $(-2)^{23}$ to $2^{23} - 1$ puts the discontinuity far away from 0. The bipolar range is achieved by sign extending the 24-bit count to 32 bits before converting to **double**.

Count Speed

From the list, choose **non-quadrature**, **1X**, **2X**, or **4X**:

- **non-quadrature** — Counts the rising edges of the A input, losing direction information in the process. The presence of a quadrature signal on the B input might cause undefined results. You should disconnect the B and index inputs.
- **1X** — Counts up or down once per complete cycle of the quadrature signal.
- **2X** — Counts up or down twice per complete cycle of the quadrature signal.
- **4X** — Counts up or down four times per complete cycle of the quadrature signal.

Filter prescale factor

Enter a base prescale factor for digital filtering. This filter helps eliminate high frequency noise. Enter a value from 0 to ff in hexadecimal (0 to 256 in decimal). For example, for a prescale factor value of ff in hexadecimal, enter

0xff

Sample time

Enter a base sample time or a multiple of the base sample time. The sample time indicates the update rate of registration on the input (Duty Cycle). Enter -1 to inherit the model sample time from another block. The sample time is in seconds.

Base address

Enter the base address of the board. This entry must correspond to the DIP switch setting on the board. For example, if the DIP switch setting is 300 (hexadecimal), enter 0x300.

Measurement Computing PCI-QUAD04 Incremental Encoder

PCI-QUAD04 Incremental Encoder block (not recommended)

Library

Simulink Real-Time Library of Drivers No Longer Recommended for Use

Description

This driver block has three block outputs: **Angle**, **Turns**, and **Init**.

You can use **Init** to determine when the block output values are valid. **Init** is first set to 0. When the encoder reached the first index, **Init** is set to 1. From then on, you can determine the exact position, direction, and velocity. **Init** remains 1 unless **Counting reset by index** is set to **Only First**, and the counter detects a rollover.

Turns is the number of complete revolutions made by the encoder. **Angle** is the amount the encoder turns since the last full revolution.

The distance is given by:

$$\text{distance} = 2 * \pi * \text{Turns} + \text{Angle}$$

The velocity is given by:

$$\text{velocity} = (\text{distance}(t_s) - \text{distance}(t_s-1)) / t_s$$

The direction is given by:

$$\text{direction} = \text{distance}(t_s) - \text{distance}(t_s-1)$$

A negative value is reverse, while a positive value is forward.

Block Parameters

Function module

From the list choose 1, 2, 3, or 4. This parameter specifies which channel you use for this block. For the same board (same base address) two blocks cannot have the same channel number.

Counting reset by index

From the list choose `Only First`, `Continuous`, or `Index input disabled`.

If you choose `Only First`, the first time the encoder reaches the index, the counter is reset to zero, the **Init** output signal is set to 1, and the encoder begins to count. The encoder ignores the second and later times it reaches the index. **Init** remains 1 until a rollover is detected, and then set to -1. A rollover is when the counter reaches its maximum value and begins to start counting at zero again. A rollover can also occur when the counter reaches its minimum value and the counter resets itself to the maximum value and resumes counting down. The outputs are still valid after rollover. The -1 flag is used to alert that a rollover has occurred.

If you choose `Continuous`, The first time the encoder reaches the index, the counter is reset to zero, the **Init** output signal is set to 1, and the encoder begins to count. Each time the encoder reaches the index, it resets to zero. **Init** remains at 1 because a rollover cannot occur.

Positive Rotation

From the list, choose either `Clockwise` or `Counter Clockwise`. This parameter sets the direction for positive rotation. If you choose `Clockwise`, when the encoder is turned clockwise it counts up, and when turned counter clockwise it counts down. If you choose `Counter Clockwise` the counting direction is reversed.

Mode

From the list, choose `Single`, `Double`, or `Quadruple`. This parameter specifies the phase detection mode. That is, how many phase changes are detected. For more information, see the board manual.

Resolution

This field specifies the divisions of the connected incremental encoder for one revolution.

Filter prescale factor

Enter a base prescale factor for digital filtering. This filter helps eliminate high frequency noise. Enter a value from 0 to ff in hexadecimal (0 to 256 in decimal). For example, for a prescale factor value of ff in hexadecimal, enter

0xff

Sample time

Enter a base sample time or a multiple of the base sample time. The sample time indicates the update rate of registration on the input (Duty Cycle). Enter -1 to inherit the model sample time from another block. The sample time is in seconds.

PCI slot (-1:autosearch)

If only one board of this type is in the target computer, enter -1 to locate the board.

If two or more boards of this type are in the target computer, enter the bus number and the PCI slot number of the board associated with this driver block. Use the format **[BusNumber,SlotNumber]**.

To determine the bus number and the PCI slot number, type:

```
tg = slrt;  
getPCIInfo(tg, 'installed')
```

Measurement Computing PCI-CTR05

Measurement Computing PCI-CTR05 board (not recommended)

Board

Measurement Computing PCI-CTR05

General Description

The PCI-CTR05 is an I/O board with 5 counter/timer channels (16-bit).

It contains one AM9513A counter/timer chip. For additional information about the various counter/timer modes of that chip see the AM9513A data sheet which is part of the board documentation.

The Simulink Real-Time product supports this board with these driver blocks:

- Measurement Computing PCI-CTR05 Counter PWM
- Measurement Computing PCI-CTR05 Counter PWM & ARM
- Measurement Computing PCI-CTR05 Counter FM
- Measurement Computing PCI-CTR05 Counter FM & ARM
- Measurement Computing PCI-CTR05 PWM Capture
- Measurement Computing PCI-CTR05 Frequency Capture
- Measurement Computing PCI-CTRxx

Board Characteristics

Board name	PCI-CTR05
Manufacturer	Measurement Computing
Bus type	PCI
Access method	I/O mapped
Multiple block instance support	Yes

Multiple board support

Yes

Measurement Computing PCI-CTR05 Counter PWM

PCI-CTR05 Counter PWM block (not recommended)

Library

Simulink Real-Time Library of Drivers No Longer Recommended for Use

Note

The PCI-CTR05 PWM driver programs the AM9513A for PWM (Pulse Width Modulation) signal generation (a square wave with fixed frequency and variable duty cycle). The block has one input which defines the variable duty cycle between 0 and 1. For the corresponding counter channel, the PWM signal is output at the pin named OUT.

Scaling Input to Output

I/O Module Output	Block Input Data Type	Scaling
TTL	Double	0 to 1

Block Parameters

Counter

From the list, choose 1, 2, 3, 4, or 5 to select which counter is used with this driver block. One block is required for each counter used.

Frequency base

From the list, choose F1=5MHz, F2=500kHz, F3=50kHz, F4=5kHz, or F5=500Hz to set the base frequency.

Relative output frequency

Enter a value between 0 and 0.25. The **Relative output frequency** is multiplied by the **Frequency base** to set the fixed output frequency of the PWM-signal.

For example, if the output frequency of a square wave has to be 17.5 kHz, then choose $F_2=100\text{kHz}$ as the **Frequency base** and enter 0.175 as the **Relative output frequency**. $100\text{ kHz} \times 0.175 = 17.5\text{ kHz}$

Level sequence of square wave

From the list, choose either **high-low** or **low-high**:

- If you choose **high-low**, the square wave period starts with the TTL high part followed by the TTL low part.
- If you choose **low-high**, the square wave period starts with the TTL low part followed by the TTL high part.

In either case, the duty cycle entering the block defines the duration of the TTL high part.

Level when disarmed

From the list, choose either **high** or **low**. The counter is automatically disarmed when the real-time application is not running and gets armed when the application begins running. This parameter sets the TTL level when the counter is disarmed.

Sample time

Enter the base sample time or a multiple of the base sample time. The sample time indicates the update rate of registration on the input (Duty Cycle)

PCI slot (-1:autosearch)

If only one board of this type is in the target computer, enter -1 to locate the board.

If two or more boards of this type are in the target computer, enter the bus number and the PCI slot number of the board associated with this driver block. Use the format **[BusNumber,SlotNumber]**.

To determine the bus number and the PCI slot number, type:

```
tg = slrt;  
getPCIInfo(tg, 'installed')
```

Measurement Computing PCI-CTR05 Counter PWM & ARM

PCI-CTR05 Counter PWM & ARM block (not recommended)

Library

Simulink Real-Time Library of Drivers No Longer Recommended for Use

Note

The PCI-CTR05 has one AM9513A chip with 5 counters.

The PCI-CTR05 PWM & ARM driver programs the AM9513A for PWM or disarmed signal generation (a square wave with fixed frequency and variable duty cycle). Additionally the driver allows to arm and disarm the counter by the second block input. For the corresponding counter channel, the PWM signal is output at the pin named OUT.

Scaling Input to Output

I/O Module Output	Block Input Data Type	Scaling
TTL	Duty cycle: Double Arm: Double	0 to 1 <0.5 disarmed ≥0.5 armed

Block Parameters

Counter

From the list, choose 1, 2, 3, 4, or 5 to select which counter is used with this driver block. One block is required for each counter used.

Frequency base

From the list, choose F1=5MHz, F2=500kHz, F3=50kHz, F4=5kHz, or F5=500Hz to set the base frequency.

Relative output frequency

Enter a value between 0 and 0.25. The **Relative output frequency** is multiplied by the **Frequency base** to set the fixed output frequency of the PWM-signal.

For example, if the output frequency of a square wave has to be 17.5 kHz, then choose $F2=100\text{kHz}$ as the **Frequency base** and enter 0.175 as the **Relative output frequency**. $100\text{ kHz} \times 0.175 = 17.5\text{ kHz}$

Level sequence of square wave

From the list, choose either **high-low** or **low-high**:

- If you choose **high-low**, the square wave period starts with the TTL high part followed by the TTL low part.
- If you choose **low-high**, the square wave period starts with the TTL low part followed by the TTL high part.

In either case, the duty cycle entering the block defines the duration of the TTL high part.

Level when disarmed

From the list, choose either **high** or **low**. The counter is automatically disarmed when the real-time application is not running. If the application is running, the second input port controls whether the counter is armed or disarmed. This parameter sets the TTL level when the counter is disarmed.

Sample time

Enter the base sample time or a multiple of the base sample time. The sample time indicates the update rate of registration on the input (Duty Cycle)

PCI slot (-1:autosearch)

If only one board of this type is in the target computer, enter -1 to locate the board.

If two or more boards of this type are in the target computer, enter the bus number and the PCI slot number of the board associated with this driver block. Use the format **[BusNumber,SlotNumber]**.

To determine the bus number and the PCI slot number, type:

```
tg = slrt;
getPCIInfo(tg, 'installed')
```

Measurement Computing PCI-CTR05 Counter FM

PCI-CTR05 Counter FM block (not recommended)

Library

Simulink Real-Time Library of Drivers No Longer Recommended for Use

Note

The PCI-CTR05 has one AM9513A chip with 5 counters.

The PCI-CTR05 FM driver programs the AM9513A for FM (Frequency Modulation) signal generation (a square wave with fixed duty cycle and variable frequency). For the corresponding counter channel, the PWM signal is output at the pin named OUT.

Scaling Input to Output

I/O Module Output	Block Input Data Type	Scaling
TTL	Double	0 to 1

Block Parameters

Counter

From the list, choose 1, 2, 3, 4, or 5 to select which counter is used with this driver block. One block is required for each counter used.

Frequency base

From the list, choose F1=5MHz, F2=500kHz, F3=50kHz, F4=5kHz, or F5=500Hz to set the base frequency.

Output duty cycle

Enter a value between 0 and 1 to set the duty cycle of the square wave. The Duty Cycle is held fixed during execution of the real-time application.

Note: Your control over the output duty cycle is not precise. See “PWM and FM Driver Block Notes” on page 1-9 for details.

Level sequence of square wave

From the list, choose either **high-low** or **low-high**:

- If you choose **high-low**, the square wave period starts with the TTL high part followed by the TTL low part.
- If you choose **low-high**, the square wave period starts with the TTL low part followed by the TTL high part.

In either case, the duty cycle entering the block defines the duration of the TTL high part.

Level when disarmed

From the list, choose either **high** or **low**. The counter is automatically disarmed when the real-time application is not running and gets armed when the application begins running. This parameter sets the TTL level when the counter is disarmed.

Sample time

Enter the base sample time or a multiple of the base sample time. The sample time indicates the update rate of registration on the input (Duty Cycle)

PCI slot (-1:autosearch)

If only one board of this type is in the target computer, enter -1 to locate the board.

If two or more boards of this type are in the target computer, enter the bus number and the PCI slot number of the board associated with this driver block. Use the format [**BusNumber**, **SlotNumber**].

To determine the bus number and the PCI slot number, type:

```
tg = slrt;  
getPCIInfo(tg, 'installed')
```

Measurement Computing PCI-CTR05 Counter FM & ARM

PCI-CTR05 Counter FM & ARM block (not recommended)

Library

Simulink Real-Time Library of Drivers No Longer Recommended for Use

Note

The PCI-CTR05 has one AM9513A chip with 5 counters.

The PCI-CTR05 FM & ARM driver programs the AM9513A for FM (Frequency Modulation) signal generation (a square wave with fixed duty cycle and variable frequency). Additionally the driver allows to arm and disarm the counter by the second block input. For the corresponding counter channel, the PWM signal is output at the pin named OUT.

Scaling Input to Output

I/O Module Output	Block Input Data Type	Scaling
TTL	Variable frequency: Double Arm: Double	<0.5 unarmed ≥0.5 armed

Block Parameters

Counter

From the list, choose 1, 2, 3, 4, 5, 6, 7, 8, 9, or 10 to select which counter is used with this driver block. One block is required for each counter used.

Frequency base

From the list, choose F1=5MHz, F2=500kHz, F3=50kHz, F4=5kHz, or F5=500Hz to set the base frequency.

Output duty cycle

Enter a value between 0 and 1 to set the duty cycle of the square wave. The Duty Cycle is held fixed during execution of the real-time application.

Note: Your control over the output duty cycle is not precise. See “PWM and FM Driver Block Notes” on page 1-9 for details.

Level sequence of square wave

From the list, choose either **high-low** or **low-high**:

- If you choose **high-low**, the square wave period starts with the TTL high part followed by the TTL low part.
- If you choose **low-high**, the square wave period starts with the TTL low part followed by the TTL high part.

In either case, the **Output duty cycle** defined in the setting above define the duration of the TTL high part.

Level when disarmed

From the list, choose either **high** or **low**. The counter is automatically disarmed when the real-time application is not running. If the application is running, the second input port controls whether the counter is armed or disarmed. This parameter sets the TTL level when the counter is disarmed.

Sample time

Enter the base sample time or a multiple of the base sample time. The sample time indicates the update rate of registration on the input (Duty Cycle)

PCI slot (-1:autosearch)

If only one board of this type is in the target computer, enter - 1 to locate the board.

If two or more boards of this type are in the target computer, enter the bus number and the PCI slot number of the board associated with this driver block. Use the format [**BusNumber**, **SlotNumber**].

To determine the bus number and the PCI slot number, type:

```
tg = slrt;
getPCIInfo(tg, 'installed')
```

Measurement Computing PCI-CTR05 PWM Capture

PCI-CTR05 PWM Capture block (not recommended)

Library

Simulink Real-Time Library of Drivers No Longer Recommended for Use

Note

This block programs the AMD9513A for capturing PWM signals by using two counters. One counter measures the cycle duration, and the other counter measures the duration the signal is high.

There are two outputs. One output is the relative frequency compared to the base frequency. The other output is the duty cycle. To get the actual frequency, multiply the base frequency by the relative frequency.

The PWM signal has to enter the pins named GATE of both corresponding counter channels (parallel wiring). Both CLK pins have to be left unconnected.

Scaling Input to Output

I/O Module Output	Block Input Data Type	Scaling
TTL	Double	0 to 1

Block Parameters

Counter

From the list, choose 1&2, 2&3, 3&4, 4&5. This selects which two counters the driver block uses to determine the PWM. One block is required for each counter used.

Frequency base

From the list, choose F1=5MHz, F2=500kHz, F3=50kHz, F4=5kHz, or F5=500Hz to set the base frequency.

Sample time

Enter the base sample time or a multiple of the base sample time. The sample time indicates the update rate of registration on the input (Duty Cycle)

PCI slot (-1:autosearch)

If only one board of this type is in the target computer, enter - 1 to locate the board.

If two or more boards of this type are in the target computer, enter the bus number and the PCI slot number of the board associated with this driver block. Use the format **[BusNumber,SlotNumber]**.

To determine the bus number and the PCI slot number, type:

```
tg = slrt;  
getPCIInfo(tg, 'installed')
```

Measurement Computing PCI-CTR05 Frequency Capture

PCI-CTR05 Frequency Capture block (not recommended)

Library

Simulink Real-Time Library of Drivers No Longer Recommended for Use

Note

This block programs the AMD9513A for capturing FM signals.

There is one output for relative frequency compared to the base frequency. To get the actual frequency, multiply the base frequency by the relative frequency.

The FM signal has to enter the pin named GATE of the corresponding counter channel. The CLK pin has to be left unconnected.

Scaling Input to Output

I/O Module Output	Block Input Data Type	Scaling
TTL	Double	0 to 1

Block Parameters

Counter

From the list, choose 1, 2, 3, 4 or 5. This selects which counter the driver block uses to determine the FM. One block is required for each counter used.

Frequency base

From the list, choose F1=5MHz, F2=500kHz, F3=50kHz, F4=5kHz, or F5=500Hz to set the base frequency.

Sample time

Enter the base sample time or a multiple of the base sample time. The sample time indicates the update rate of registration on the input (Duty Cycle)

PCI slot (-1:autosearch)

If only one board of this type is in the target computer, enter - 1 to locate the board.

If two or more boards of this type are in the target computer, enter the bus number and the PCI slot number of the board associated with this driver block. Use the format **[BusNumber,SlotNumber]**.

To determine the bus number and the PCI slot number, type:

```
tg = slrt;  
getPCIInfo(tg, 'installed')
```

Measurement Computing PCI-CTRxx

PCI-CTRxx block (not recommended)

Library

Simulink Real-Time Library of Drivers No Longer Recommended for Use

Note

You can use this block to program the AMD9513A counter. The PWM, PWM & ARM, FM, FM & ARM, PWM Capture, and Frequency Capture blocks use this block in their underlying subsystems. The API for this block is not currently documented.

Measurement Computing PCI-DAS1002

Support for the MC PCI-DAS1002 I/O board (not recommended)

Board

Measurement Computing PCI-DAS1002

General Description

The PCI-DAS1002 is an I/O board with 16 single or 8 differential analog input (A/D) channels (12-bit) with a maximum sample rate of 200 kHz, 2 analog output (D/A) channels (12-bit), and 24 digital input and output lines.

The Simulink Real-Time block library supports this board with these driver blocks:

- Measurement Computing PCI-DAS1002 Analog Input (A/D)
- Measurement Computing PCI-DAS1002 Analog Output (D/A)
- Measurement Computing PCI-DAS1002 Digital Input
- Measurement Computing PCI-DAS1002 Digital Output

Board Characteristics

Board name	PCI-DAS1002
Manufacturer	Measurement Computing
Bus type	PCI
Access method	I/O mapped
Multiple block instance support	A/D — one block per board D/A — each input port can be in one block
Multiple board support	Digital I/O — one block per 8-bit port Yes

Measurement Computing PCI-DAS1002 Analog Input (A/D)

PCI-DAS1002 Analog Input block (not recommended)

Library

Simulink Real-Time Library of Drivers No Longer Recommended for Use

Scaling Input to Output

I/O Module Input	Block Output Data Type	Scaling
Volts	Double	1

Block Parameters

Number of Channels

Enter N , the number of channels to acquire. This board acquires data from channels 1 to N .

- Enter N as a value between 1 and 16 if **Input coupling** is **Single-ended** (16 channels).
- Enter N as a value between 1 and 8 if **Input coupling** is **Differential** (8 channels).

This driver does not allow the selection of individual channels or to mix single-ended and differential inputs.

Number the lines beginning with 1 even if this board manufacturer numbers the lines beginning with 0.

Range vector

From the list, choose either $\pm 10V$ (-10 volts to +10 volts), $\pm 5V$, $\pm 2.5V$, $\pm 1.25V$, $0-10V$, $0-5V$, $0-2.5V$, or $0-1.25V$. This driver does not allow the selection of a different range for each channel.

Input coupling

From the list, select one of the following input modes:

- Single-ended (16 channels)
- Differential (8 channels)

Sample time

Enter the base sample time or a multiple of the base sample time (- 1 means sample time is inherited).

PCI slot (-1:autosearch)

If only one board of this type is in the target computer, enter - 1 to locate the board.

If two or more boards of this type are in the target computer, enter the bus number and the PCI slot number of the board associated with this driver block. Use the format [**BusNumber,SlotNumber**].

To determine the bus number and the PCI slot number, type:

```
tg = slrt;  
getPCIInfo(tg, 'installed')
```

Measurement Computing PCI-DAS1002 Analog Output (D/A)

PCI-DAS1002 Analog Output block (not recommended)

Library

Simulink Real-Time Library of Drivers No Longer Recommended for Use

Scaling Input to Output

I/O Module Output	Block Input Data Type	Scaling
Volts	Double	1

Block Parameters

Channel vector

Enter 1 or 2. This driver allows the selection of individual D/A channels in arbitrary order. The number of elements defines the number of D/A channels used. For example, to use both of the analog output channels, enter

[1,2]

Number the channels beginning with 1 even if this board manufacturer starts numbering the channels with 0.

Range vector

Enter a range code for each of the channels in the channel vector. The range vector must be the same length as the channel vector. This board allows the range of each channel to be different.

The following table is a list of the ranges for this driver and the corresponding range codes.

Input Range (V)	Range Code
-10 to +10	-10

Input Range (V)	Range Code
-5 to +5	-5
0 to +10	10
0 to +5	5

For example, if the first channel is -10 to +10 volts and the second channel is 0 to +5 volts, enter

```
[ -10,5]
```

Reset vector

The reset vector controls the behavior of the channel at model termination. Enter a scalar or a vector that is the same length as the channel vector. If you specify a scalar value, that setting is replicated over the channel vector. If you specify a value of 1, the corresponding channel is reset to the value specified in the initial value vector. If you specify a value of 0, the channel remains at the last value attained while the model was running.

Initial value vector

The initial value vector contains the initial voltage values for the output channels. Enter a scalar or a vector that is the same length as the channel vector. If you specify a scalar value, that value is replicated as the initial value over the channel vector. The channels are set to the initial values between the time the model is downloaded and the time it is started.

Sample time

Enter the base sample time or a multiple of the base sample time (- 1 means sample time is inherited).

PCI slot (-1:autosearch)

If only one board of this type is in the target computer, enter - 1 to locate the board.

If two or more boards of this type are in the target computer, enter the bus number and the PCI slot number of the board associated with this driver block. Use the format [**BusNumber**,**SlotNumber**].

To determine the bus number and the PCI slot number, type:

```
tg = slrt;
getPCIInfo(tg, 'installed')
```

Measurement Computing PCI-DAS1002 Digital Input

PCI-DAS1002 Digital Input block (not recommended)

Library

Simulink Real-Time Library of Drivers No Longer Recommended for Use

Note

The PCI-DAS1002 has one 8255 chip with 3 ports (A,B,C). Each port has a maximum of 8 digital I/O lines that can be configured as inputs or outputs.

Use a separate driver block for each port. By selecting the digital input driver block, the port is configured as input.

Scaling Input to Output

I/O Module Input	Block Output Data Type	Scaling
TTL	Double	TTL low = 0.0 TTL high = 1.0

Block Parameters

Channel vector

Enter numbers between 1 and 8 to select the digital input lines used with this port. This driver allows the selection of individual digital input lines in arbitrary order. The number of elements defines the number of digital lines used.

For example, to use all of the digital inputs for one port, enter

```
[1,2,3,4,5,6,7,8]
```

Number the lines beginning with 1 even if this board manufacturer numbers the lines beginning with 0.

Port

From the list, choose either **A**, **B**, or **C**. The I/O board has an 8255 chip with 3 ports. The **Port** parameter defines which port of the 8255 chip is used for this driver block. Each port has a maximum of 8 digital lines that can be configured as inputs or outputs depending on which driver block is chosen. In each case, one block is required for each port.

Sample time

Enter the base sample time or a multiple of the base sample time (- 1 means sample time is inherited).

PCI slot (-1:autosearch)

If only one board of this type is in the target computer, enter -1 to locate the board.

If two or more boards of this type are in the target computer, enter the bus number and the PCI slot number of the board associated with this driver block. Use the format [**BusNumber**,**SlotNumber**].

To determine the bus number and the PCI slot number, type:

```
tg = slrt;  
getPCIInfo(tg, 'installed')
```

Measurement Computing PCI-DAS1002 Digital Output

PCI-DAS1002 Digital Output block (not recommended)

Library

Simulink Real-Time Library of Drivers No Longer Recommended for Use

Note

The PCI-DAS1002 has one 8255 chip with 3 ports (A,B,C). Each port has a maximum of 8 digital I/O lines that can be configured as inputs or outputs.

Use a separate driver block for each port. By selecting the digital output driver block, the port is configured as output.

Scaling Input to Output

I/O Module Output	Block Input Data Type	Scaling
TTL	Double	< 0.5 = TTL low ≥ 0.5 = TTL high

Block Parameters

Channel vector

Enter numbers between 1 and 8 to select the digital output lines used with this port. This driver allows the selection of individual digital output lines in arbitrary order. The number of elements defines the number of digital lines used.

For example, to use all of the digital outputs for one port, enter

```
[1,2,3,4,5,6,7,8]
```

Number the lines beginning with 1 even if this board manufacturer numbers the lines beginning with 0.

Port

From the list, choose either **A**, **B**, or **C**. The I/O board has an 8255 chip with 3 ports. The **Port** parameter defines which port of the 8255 chip is used for this driver block. Each port has a maximum of 8 digital lines that can be configured as inputs or outputs depending on which driver block is chosen. In each case, one block is required for each port.

Reset vector

The reset vector controls the behavior of the channel at model termination. Enter a scalar or a vector that is the same length as the channel vector. If you specify a scalar value, that setting is replicated over the channel vector. If you specify a value of 1, the corresponding channel is reset to the value specified in the initial value vector. If you specify a value of 0, the channel remains at the last value attained while the model was running.

Initial value vector

The initial value vector contains the initial values (0 or 1) of the output channels. Enter a scalar or a vector that is the same length as the channel vector. If you enter a scalar, that value is replicated as the initial value over the channel vector. The channels are set to these initial values between the time the model is downloaded and the time it is started.

Sample time

Enter the base sample time or a multiple of the base sample time (-1 means sample time is inherited).

PCI slot (-1:autosearch)

If only one board of this type is in the target computer, enter -1 to locate the board.

If two or more boards of this type are in the target computer, enter the bus number and the PCI slot number of the board associated with this driver block. Use the format [**BusNumber**,**SlotNumber**].

To determine the bus number and the PCI slot number, type:

```
tg = slrt;  
getPCIInfo(tg, 'installed')
```

Measurement Computing PCI-DAS1200

Support for the MC PCI-DAS1200 I/O board (not recommended)

Board

Measurement Computing PCI-DAS1200

General Description

The PCI-DAS1200 is an I/O board with 16 single or 8 differential analog input (A/D) channels (12-bit) with a maximum sample rate of 330 kHz, 2 analog output (D/A) channels (12-bit), and 24 digital input and output lines.

The Simulink Real-Time block library supports this board with these driver blocks:

- Measurement Computing PCI-DAS1200 Analog Input (A/D)
- Measurement Computing PCI-DAS1200 Analog Output (D/A)
- Measurement Computing PCI-DAS1200 Digital Input
- Measurement Computing PCI-DAS1200 Digital Output

Board Characteristics

Board name	PCI-DAS1200
Manufacturer	Measurement Computing
Bus type	PCI
Access method	I/O mapped
Multiple block instance support	A/D: No, D/A: Yes, Digital I/O: Yes
Multiple board support	Yes

Measurement Computing PCI-DAS1200 Analog Input (A/D)

PCI-DAS1200 Analog Input block (not recommended)

Library

Simulink Real-Time Library of Drivers No Longer Recommended for Use

Scaling Input to Output

I/O Module Input	Block Output Data Type	Scaling
Volts	Double	1

Block Parameters

Number of Channels

Enter N , the number of channels to acquire. This board acquires data from channels 1 to N .

- Enter N as a value between 1 and 16 if **Input coupling** is **Single-ended** (16 channels).
- Enter N as a value between 1 and 8 if **Input coupling** is **Differential** (8 channels).

This driver does not allow the selection of individual channels or to mix single-ended and differential inputs.

Number the lines beginning with 1 even if this board manufacturer numbers the lines beginning with 0.

Range

From the list, choose either $\pm 10V$ (-10 volts to +10 volts), $\pm 5V$, $\pm 2.5V$, $\pm 1.25V$, $0-10V$, $0-5V$, $0-2.5V$, or $0-1.25V$. This driver does not allow the selection of different range for each channel.

Input coupling

From the list, select one from the following list of input modes:

- Single-ended channels (16 channels)
- Differential channels (8 channels)

Sample time

Enter the base sample time or a multiple of the base sample time (- 1 means sample time is inherited).

PCI slot (-1:autosearch)

If only one board of this type is in the target computer, enter - 1 to locate the board.

If two or more boards of this type are in the target computer, enter the bus number and the PCI slot number of the board associated with this driver block. Use the format [**BusNumber,SlotNumber**].

To determine the bus number and the PCI slot number, type:

```
tg = slrt;  
getPCIInfo(tg, 'installed')
```

Measurement Computing PCI-DAS1200 Analog Output (D/A)

PCI-DAS1200 Analog Output block (not recommended)

Library

Simulink Real-Time Library of Drivers No Longer Recommended for Use

Scaling Input to Output

I/O Module Output	Block Input Data Type	Scaling
Volts	Double	1

Block Parameters

Channel vector

Enter 1 or 2. This driver allows the selection of individual D/A channels in arbitrary order. The number of elements defines the number of D/A channels used. For example, to use both of the analog output channels, enter

[1,2]

Number the channels beginning with 1 even if this board manufacturer starts numbering the channels with 0.

Range vector

Enter a range code for each of the channels in the channel vector. The range vector must be the same length as the channel vector. This board allows the range of each channel to be different.

The following table is a list of the ranges for this driver and the corresponding range codes.

Input Range (V)	Range Code
-10 to +10	-10

Input Range (V)	Range Code
-5 to +5	-5
0 to +10	10
0 to +5	5

For example, if the first channel is -10 to +10 volts and the second channel is 0 to +5 volts, enter

```
[ -10,5]
```

Reset vector

The reset vector controls the behavior of the channel at model termination. Enter a scalar or a vector that is the same length as the channel vector. If you specify a scalar value, that setting is replicated over the channel vector. If you specify a value of 1, the corresponding channel is reset to the value specified in the initial value vector. If you specify a value of 0, the channel remains at the last value attained while the model was running.

Initial value vector

The initial value vector contains the initial voltage values for the output channels. Enter a scalar or a vector that is the same length as the channel vector. If you specify a scalar value, that value is replicated as the initial value over the channel vector. The channels are set to the initial values between the time the model is downloaded and the time it is started.

Sample time

Enter the base sample time or a multiple of the base sample time (-1 means sample time is inherited).

PCI slot (-1:autosearch)

If only one board of this type is in the target computer, enter -1 to locate the board.

If two or more boards of this type are in the target computer, enter the bus number and the PCI slot number of the board associated with this driver block. Use the format [**BusNumber**,**SlotNumber**].

To determine the bus number and the PCI slot number, type:

```
tg = slrt;
getPCIInfo(tg, 'installed')
```

Measurement Computing PCI-DAS1200 Digital Input

PCI-DAS1200 Digital Input block (not recommended)

Library

Simulink Real-Time Library of Drivers No Longer Recommended for Use

Note

The PCI-DAS1200 has one 8255 chip with 3 ports (A,B,C). Each port has a maximum of 8 digital I/O lines that can be configured as inputs or outputs.

Use a separate driver block for each port. By selecting the digital input driver block, the port is configured as input.

Scaling Input to Output

I/O Module Input	Block Output Data Type	Scaling
TTL	Double	TTL low = 0.0 TTL high = 1.0

Block Parameters

Channel vector

Enter numbers between 1 and 8 to select the digital input lines used with this port. This driver allows the selection of individual digital input lines in arbitrary order. The number of elements defines the number of digital lines used.

For example, to use all of the digital inputs for one port, enter

```
[1,2,3,4,5,6,7,8]
```

Number the lines beginning with 1 even if this board manufacturer numbers the lines beginning with 0.

Port

From the list choose either **A**, **B**, or **C**. The I/O board has an 8255 chip with 3 ports. The **Port** parameter defines which port of the 8255 chip is used for this driver block. Each port has a maximum of 8 digital lines that can be configured as inputs or outputs depending on which driver block is chosen. In each case, one block is required for each port.

Sample time

Enter the base sample time or a multiple of the base sample time (- 1 means sample time is inherited).

PCI slot (-1:autosearch)

If only one board of this type is in the target computer, enter -1 to locate the board.

If two or more boards of this type are in the target computer, enter the bus number and the PCI slot number of the board associated with this driver block. Use the format [**BusNumber**,**SlotNumber**].

To determine the bus number and the PCI slot number, type:

```
tg = slrt;  
getPCIInfo(tg, 'installed')
```

Measurement Computing PCI-DAS1200 Digital Output

PCI-DAS1200 Digital Output block (not recommended)

Library

Simulink Real-Time Library of Drivers No Longer Recommended for Use

Note

The PCI-DAS1200 has one 8255 chip with 3 ports (A,B,C). Each port has a maximum of 8 digital I/O lines that can be configured as inputs or outputs.

Use a separate driver block for each port. By selecting the digital output driver block, the port is configured as output.

Scaling Input to Output

I/O Module Output	Block Input Data Type	Scaling
TTL	Double	$< 0.5 = \text{TTL low}$ $\geq 0.5 = \text{TTL high}$

Block Parameters

Channel vector

Enter numbers between 1 and 8 to select the digital output lines used with this port. This driver allows the selection of individual digital output lines in arbitrary order. The number of elements defines the number of digital lines used.

For example, to use all of the digital outputs for one port, enter

[1,2,3,4,5,6,7,8]

Number the lines beginning with 1 even if this board manufacturer numbers the lines beginning with 0.

Port

From the list choose either **A**, **B**, or **C**. The I/O board has an 8255 chip with 3 ports. The **Port** parameter defines which port of the 8255 chip is used for this driver block. Each port has a maximum of 8 digital lines that can be configured as inputs or outputs depending on which driver block is chosen. In each case, one block is required for each port.

Reset vector

The reset vector controls the behavior of the channel at model termination. Enter a scalar or a vector that is the same length as the channel vector. If you specify a scalar value, that setting is replicated over the channel vector. If you specify a value of 1, the corresponding channel is reset to the value specified in the initial value vector. If you specify a value of 0, the channel remains at the last value attained while the model was running.

Initial value vector

The initial value vector contains the initial values (0 or 1) of the output channels. Enter a scalar or a vector that is the same length as the channel vector. If you enter a scalar, that value is replicated as the initial value over the channel vector. The channels are set to these initial values between the time the model is downloaded and the time it is started.

Sample time

Enter the base sample time or a multiple of the base sample time (-1 means sample time is inherited).

PCI slot (-1:autosearch)

If only one board of this type is in the target computer, enter -1 to locate the board.

If two or more boards of this type are in the target computer, enter the bus number and the PCI slot number of the board associated with this driver block. Use the format [**BusNumber**,**SlotNumber**].

To determine the bus number and the PCI slot number, type:

```
tg = slrt;  
getPCIInfo(tg, 'installed')
```

Measurement Computing PCI-DAS1200/JR

Support for the MC PCI-DAS1200/JR I/O board (not recommended)

Board

Measurement Computing PCI-DAS1200/JR

General Description

The PCI-DAS1200/JR is an I/O board with 16 single or 8 differential analog input (A/D) channels (12-bit) with a maximum sample rate of 330 kHz, and 24 digital I/O lines.

The Simulink Real-Time block library supports this board with these driver blocks:

- Measurement Computing PCI-DAS1200/JR Analog Input (A/D)
- Measurement Computing PCI-DAS1200/JR Digital Input
- Measurement Computing PCI-DAS1200/JR Digital Output

Board Characteristics

Board name	PCI-DAS1200/JR
Manufacturer	Measurement Computing
Bus type	PCI
Access method	I/O mapped
Multiple block instance support	A/D: No, Digital I/O: Yes
Multiple board support	Yes

Measurement Computing PCI-DAS1200/JR Analog Input (A/D)

PCI-DAS1200/JR Analog Input block (not recommended)

Library

Simulink Real-Time Library of Drivers No Longer Recommended for Use

Scaling Input to Output

I/O Module Input	Block Output Data Type	Scaling
Volts	Double	1

Block Parameters

Number of Channels

If you select 16 channels (**Input coupling** parameter set to 16 **single-ended channels**) enter a number between 1 and 16 to select the number of A/D channels used. If you select eight channels (**Input coupling** parameter set to 8 **differential channels**) enter a number between 1 and 8. This driver does not allow the selection of individual channels or to mix single-ended and differential inputs.

Number the lines beginning with 1 even if this board manufacturer numbers the lines beginning with 0.

Range

From the list, choose either $\pm 10V$ (-10 volts to +10 volts), $\pm 5V$, $\pm 2.5V$, $\pm 1.25V$, $0-10V$, $0-5V$, $0-2.5V$, or $0-1.25V$. This driver does not allow the selection of different range for each channel.

Input coupling

From the list, select one from the following list of input modes:

- Single-ended channels (16 channels)
- Differential channels (8 channels)

This choice must correspond to the MUX-switch setting on the board.

Sample time

Enter the base sample time or a multiple of the base sample time (- 1 means sample time is inherited).

PCI slot (-1:autosearch)

If only one board of this type is in the target computer, enter - 1 to locate the board.

If two or more boards of this type are in the target computer, enter the bus number and the PCI slot number of the board associated with this driver block. Use the format **[BusNumber,SlotNumber]**.

To determine the bus number and the PCI slot number, type:

```
tg = slrt;  
getPCIInfo(tg, 'installed')
```

Measurement Computing PCI-DAS1200/JR Digital Input

PCI-DAS1200/JR Digital Input block (not recommended)

Library

Simulink Real-Time Library of Drivers No Longer Recommended for Use

Note

The PCI-DAS1200/JR has one 8255 chip with 3 ports (A,B,C). Each port has a maximum of 8 digital I/O lines that can be configured as inputs or outputs.

Use a separate driver block for each port. By selecting the digital input driver block, the port is configured as input.

Scaling Input to Output

I/O Module Input	Block Output Data Type	Scaling
TTL	Double	TTL low = 0.0 TTL high = 1.0

Block Parameters

Channel vector

Enter numbers between 1 and 8 to select the digital input lines used with this port. This driver allows the selection of individual digital input lines in arbitrary order. The number of elements defines the number of digital lines used.

For example, to use all of the digital inputs for one port, enter

[1,2,3,4,5,6,7,8]

Number the lines beginning with 1 even if this board manufacturer numbers the lines beginning with 0.

Port

From the list choose either A, B, or C. The I/O board has an 8255 chip with 3 ports. The **Port** parameter defines which port of the 8255 chip is used for this driver block. Each port has a maximum of 8 digital lines that can be configured as inputs or outputs depending on which driver block is chosen. In each case, one block is required for each port.

Sample time

Enter the base sample time or a multiple of the base sample time (- 1 means sample time is inherited).

PCI slot (-1:autosearch)

If only one board of this type is in the target computer, enter - 1 to locate the board.

If two or more boards of this type are in the target computer, enter the bus number and the PCI slot number of the board associated with this driver block. Use the format **[BusNumber, SlotNumber]**.

To determine the bus number and the PCI slot number, type:

```
tg = slrt;  
getPCIInfo(tg, 'installed')
```

Measurement Computing PCI-DAS1200/JR Digital Output

PCI-DAS1200/JR Digital Output block (not recommended)

Library

Simulink Real-Time Library of Drivers No Longer Recommended for Use

Note

The PCI-DAS1200 has one 8255 chip with 3 ports (A,B,C). Each port has a maximum of 8 digital I/O lines that can be configured as inputs or outputs.

Use a separate driver block for each port. By selecting the digital output driver block, the port is configured as output.

Scaling Input to Output

I/O Module Output	Block Input Data Type	Scaling
TTL	Double	$< 0.5 = \text{TTL low}$ $\geq 0.5 = \text{TTL high}$

Block Parameters

Channel vector

Enter numbers between 1 and 8 to select the digital output lines used with this port. This driver allows the selection of individual digital output lines in arbitrary order. The number of elements defines the number of digital lines used.

For example, to use all of the digital outputs for one port, enter

[1,2,3,4,5,6,7,8]

Number the lines beginning with 1 even if this board manufacturer numbers the lines beginning with 0.

Port

From the list choose either A, B, or C. The I/O board has an 8255 chip with 3 ports. The **Port** parameter defines which port of the 8255 chip is used for this driver block. Each port has a maximum of 8 digital lines that can be configured as inputs or outputs depending on which driver block is chosen. In each case, one block is required for each port.

Reset vector

The reset vector controls the behavior of the channel at model termination. Enter a scalar or a vector that is the same length as the channel vector. If you specify a scalar value, that setting is replicated over the channel vector. If you specify a value of 1, the corresponding channel is reset to the value specified in the initial value vector. If you specify a value of 0, the channel remains at the last value attained while the model was running.

Initial value vector

The initial value vector contains the initial values (0 or 1) of the output channels. Enter a scalar or a vector that is the same length as the channel vector. If you enter a scalar, that value is replicated as the initial value over the channel vector. The channels are set to these initial values between the time the model is downloaded and the time it is started.

Sample time

Enter the base sample time or a multiple of the base sample time (-1 means sample time is inherited).

PCI slot (-1:autosearch)

If only one board of this type is in the target computer, enter -1 to locate the board.

If two or more boards of this type are in the target computer, enter the bus number and the PCI slot number of the board associated with this driver block. Use the format [**BusNumber,SlotNumber**].

To determine the bus number and the PCI slot number, type:

```
tg = slrt;  
getPCIInfo(tg, 'installed')
```

Measurement Computing PCI-DAS1602/12

Support for the MC PCI-DAS1602/12 I/O board (not recommended)

Board

Measurement Computing PCI-DAS1602/12

General Description

The PCI-DAS1602/12 is an I/O board with 16 single or 8 differential analog input (A/D) channels (12-bit) with a maximum sampling rate of 200 kHz, 2 analog output (D/A) channels (12-bit), and 24 digital input and output lines and 3 counters (16-bit).

The Simulink Real-Time block library supports this board with these driver blocks:

- Measurement Computing PCI-DAS1602/12 Analog Input (A/D)
- Measurement Computing PCI-DAS1602/12 Analog Output (D/A)
- Measurement Computing PCI-DAS 1602/12 Digital Input
- Measurement Computing PCI-DAS1602/12 Digital Output

Note: The Simulink Real-Time software supports only 24 digital I/O lines and does not support the counters on this board.

Board Characteristics

Board Name	PCI-DAS1602/12
Manufacturer	Measurement Computing
Bus type	ISA
Access method	I/O mapped
Multiple block instance support	Yes
Multiple board support	Yes

Measurement Computing PCI-DAS1602/12 Analog Input (A/D)

PCI-DAS1602/12 Analog Input block (not recommended)

Library

Simulink Real-Time Library of Drivers No Longer Recommended for Use

Scaling of Input to Output

I/O Module Input	Block Output Data Type	Scaling
Volts	Double	1

Block Parameters

Number of channels

If you select 16 channels (**Input coupling** parameter set to 16 **single-ended channels**) enter a number between 1 and 16 to select the number of A/D channels used. If you select eight channels (**Input coupling** parameter set to 8 **differential channels**) enter a number between 1 and 8. This driver does not allow the selection of individual channels or to mix single-ended and differential inputs.

Number the lines beginning with 1 even if this board manufacturer numbers the lines beginning with 0.

Range

From the list, choose either $\pm 10V$ (-10 volts to +10 volts), $\pm 5V$, $\pm 2.5V$, $\pm 1.25V$, $\pm 0.625V$, $0-10V$, $0-5V$, $0-2.5V$, or $0-1.25V$. This driver does not allow the selection of a different range for each channel.

Input coupling

From the list, select one from the following list of input modes:

- Single-ended channels (16 channels)
- Differential channels (8 channels)

Sample time

Enter the base sample time or a multiple of the base sample time (- 1 means sample time is inherited).

PCI slot (-1:autosearch)

If only one board of this type is in the target computer, enter - 1 to locate the board.

If two or more boards of this type are in the target computer, enter the bus number and the PCI slot number of the board associated with this driver block. Use the format **[BusNumber,SlotNumber]**.

To determine the bus number and the PCI slot number, type:

```
tg = slrt;  
getPCIInfo(tg, 'installed')
```

Measurement Computing PCI-DAS1602/12 Analog Output (D/A)

PCI-DAS1602/12 Analog Output block (not recommended)

Library

Simulink Real-Time Library of Drivers No Longer Recommended for Use

Scaling of Input to Output

I/O Module Output	Block Input Data Type	Scaling
Volts	Double	1

Block Parameters

Channel vector

Enter 1 or 2. This driver allows the selection of individual D/A channels in arbitrary order. The number of elements defines the number of D/A channels used. For example, to use the first and second analog output (D/A) channels, enter

[1,2]

Number channels begin with 1 even if this board manufacturer starts numbering channels with 0.

Range vector

Enter a range code for each of the channels in the channel vector. The range vector must be the same length as the channel vector. This board allows the range of each channel to be different.

The following table is a list of the ranges for this driver and the corresponding range codes.

Input Range (V)	Range Code
-10 to +10	-10

Input Range (V)	Range Code
-5 to +5	-5
0 to +10	10
0 to +5	5

For example, if the first channel is -10 to +10 volts and the second channel is 0 to +5 volts, enter

```
[ -10,5]
```

Reset vector

The reset vector controls the behavior of the channel at model termination. Enter a scalar or a vector that is the same length as the channel vector. If you specify a scalar value, that setting is replicated over the channel vector. If you specify a value of 1, the corresponding channel is reset to the value specified in the initial value vector. If you specify a value of 0, the channel remains at the last value attained while the model was running.

Initial value vector

The initial value vector contains the initial voltage values for the output channels. Enter a scalar or a vector that is the same length as the channel vector. If you specify a scalar value, that value is replicated as the initial value over the channel vector. The channels are set to the initial values between the time the model is downloaded and the time it is started.

Sample time

Enter the base sample time or a multiple of the base sample time (-1 means sample time is inherited).

PCI slot (-1:autosearch)

If only one board of this type is in the target computer, enter -1 to locate the board.

If two or more boards of this type are in the target computer, enter the bus number and the PCI slot number of the board associated with this driver block. Use the format [**BusNumber**,**SlotNumber**].

To determine the bus number and the PCI slot number, type:

```
tg = slrt;
getPCIInfo(tg, 'installed')
```

Measurement Computing PCI-DAS 1602/12 Digital Input

PCI-DAS 1602/12 Digital Input (not recommended)

Library

Simulink Real-Time Library of Drivers No Longer Recommended for Use

Note

The DAS1601/12 has an 8255 chip with 3 ports (A,B,C). Each port has a maximum of 8 digital I/O lines that can be configured as inputs or outputs.

Use a separate driver block for each port. By selecting the digital input driver block, the port is configured as input.

Scaling of Input to Output

I/O Module Input	Block Output Data Type	Scaling
TTL	Double	TTL low = 0.0 TTL high = 1.0

Block Parameters

Channel vector

Enter numbers between 1 and 8 to select the digital input lines used with this port. This driver allows the selection of individual digital input lines in arbitrary order. The number of elements defines the number of digital lines used.

For example, to use all of the digital inputs for one port, enter

[1,2,3,4,5,6,7,8]

Number the lines beginning with 1 even if this board manufacturer numbers the lines beginning with 0.

Port

From the list choose either A, B, or C. The I/O board has an 8255 chip with 3 ports. The port name defines which port of the 8255 chip is used for this driver block. Each port has a maximum of 8 digital lines that can be configured as inputs or outputs depending on which driver block is chosen. In each case, one block is required for each port.

Sample time

Enter the base sample time or a multiple of the base sample time (- 1 means sample time is inherited).

PCI slot (-1:autosearch)

If only one board of this type is in the target computer, enter - 1 to locate the board.

If two or more boards of this type are in the target computer, enter the bus number and the PCI slot number of the board associated with this driver block. Use the format **[BusNumber, SlotNumber]**.

To determine the bus number and the PCI slot number, type:

```
tg = slrt;  
getPCIInfo(tg, 'installed')
```

Measurement Computing PCI-DAS1602/12 Digital Output

PCI-DAS1602/12 Digital Output (not recommended)

Library

Simulink Real-Time Library of Drivers No Longer Recommended for Use

Note

The DAS1601/12 has an 8255 chip with 3 ports (A,B,C). Each port has a maximum of 8 digital I/O lines that can be configured as inputs or outputs.

Use a separate driver block for each port. By selecting the digital output driver block, the port is configured as output.

Scaling of Input to Output

I/O Module Output	Block Input Data Type	Scaling
TTL	Double	$< 0.5 = \text{TTL low}$ $\geq 0.5 = \text{TTL high}$

Block Parameters

Channel vector

Enter numbers between 1 and 8 to select the digital output lines used with this port. This driver allows the selection of individual digital output lines in arbitrary order. The number of elements defines the number of digital lines used.

For example, to use all of the digital outputs for one port, enter

[1,2,3,4,5,6,7,8]

Number the lines beginning with 1 even if this board manufacturer numbers the lines beginning with 0.

Port

From the list choose either **A**, **B**, or **C**. The I/O board has an 8255 chip with 3 ports. The port name defines which port of the 8255 chip is used for this driver block. Each port has a maximum of 8 digital lines that can be configured as inputs or outputs depending on which driver block is chosen. In each case, one block is required for each port.

Reset vector

The reset vector controls the behavior of the channel at model termination. Enter a scalar or a vector that is the same length as the channel vector. If you specify a scalar value, that setting is replicated over the channel vector. If you specify a value of 1, the corresponding channel is reset to the value specified in the initial value vector. If you specify a value of 0, the channel remains at the last value attained while the model was running.

Initial value vector

The initial value vector contains the initial values (0 or 1) of the output channels. Enter a scalar or a vector that is the same length as the channel vector. If you enter a scalar, that value is replicated as the initial value over the channel vector. The channels are set to these initial values between the time the model is downloaded and the time it is started.

Sample time

Enter the base sample time or a multiple of the base sample time (-1 means sample time is inherited).

PCI slot (-1:autosearch)

If only one board of this type is in the target computer, enter -1 to locate the board.

If two or more boards of this type are in the target computer, enter the bus number and the PCI slot number of the board associated with this driver block. Use the format [**BusNumber**,**SlotNumber**].

To determine the bus number and the PCI slot number, type:

```
tg = slrt;  
getPCIInfo(tg, 'installed')
```

Measurement Computing PCI-DAS1602/16

Support for the MC PCI-DAS1602/16 I/O board (not recommended)

Board

Measurement Computing PCI-DAS1602/16

General Description

The PCI-DAS1602/16 is an I/O board with 16 single or 8 differential analog input (A/D) channels (16-bit) with a maximum sampling rate of 200 kHz, 2 analog output (D/A) channels (16-bit), and 24 digital input and output lines and 3 counters (16-bit).

The Simulink Real-Time block library supports this board with these driver blocks:

- Measurement Computing PCI-DAS1602/16 Analog Input (A/D)
- Measurement Computing PCI-DAS1602/16 Analog Output (D/A)
- Measurement Computing PCI-DAS 1602/16 Digital Input
- Measurement Computing PCI-DAS1602/16 Digital Output

Note: The Simulink Real-Time software supports only 24 digital I/O lines and does not support the counters on this board.

Board Characteristics

Board Name	PCI-DAS1602/16
Manufacturer	Measurement Computing
Bus type	ISA
Access method	I/O mapped
Multiple block instance support	Yes
Multiple board support	Yes

Measurement Computing PCI-DAS1602/16 Analog Input (A/D)

PCI-DAS1602/16 Analog Input block (not recommended)

Library

Simulink Real-Time Library of Drivers No Longer Recommended for Use

Scaling of Input to Output

I/O Module Input	Block Output Data Type	Scaling
Volts	Double	1

Block Parameters

Number of channels

If you select 16 channels (**Input coupling** parameter set to 16 **single-ended channels**) enter a number between 1 and 16 to select the number of A/D channels used. If you select eight channels (**Input coupling** parameter set to 8 **differential channels**) enter a number between 1 and 8. This driver does not allow the selection of individual channels or to mix single-ended and differential inputs.

Number the lines beginning with 1 even if this board manufacturer numbers the lines beginning with 0.

Range

From the list, choose either $\pm 10V$ (-10 volts to +10 volts), $\pm 5V$, $\pm 2.5V$, $\pm 1.25V$, $\pm 0.625V$, $0-10V$, $0-5V$, $0-2.5V$, or $0-1.25V$. This driver does not allow the selection of a different range for each channel.

Input coupling

From the list, select one from the following list of input modes:

- Single-ended channels (16 channels)
- Differential channels (8 channels)

Sample time

Enter the base sample time or a multiple of the base sample time (- 1 means sample time is inherited).

PCI slot (-1:autosearch)

If only one board of this type is in the target computer, enter - 1 to locate the board.

If two or more boards of this type are in the target computer, enter the bus number and the PCI slot number of the board associated with this driver block. Use the format **[BusNumber,SlotNumber]**.

To determine the bus number and the PCI slot number, type:

```
tg = slrt;  
getPCIInfo(tg, 'installed')
```

Measurement Computing PCI-DAS1602/16 Analog Output (D/A)

PCI-DAS1602/16 Analog Output block (not recommended)

Library

Simulink Real-Time Library of Drivers No Longer Recommended for Use

Scaling of Input to Output

I/O Module Output	Block Input Data Type	Scaling
Volts	Double	1

Block Parameters

Channel vector

Enter numbers 1 or 2. This driver allows the selection of individual D/A channels in arbitrary order. The number of elements defines the number of D/A channels used. For example, to use the first and second analog output (D/A) channels, enter

[1,2]

Number channels begin with 1 even if this board manufacturer starts numbering channels with 0.

Range vector

Enter a vector or range codes to specify the ranges of each of the channels. This must be a vector of the same length as the channel vector. Otherwise, a scalar is assumed to apply to each channel.

The following table is a list of the ranges for this driver and the corresponding range codes.

Input Range (V)	Range Code
-10 to +10	-10

Input Range (V)	Range Code
-5 to +5	-5
0 to +10	10
0 to +5	5

For example, if the first channel is -10 to +10 volts and the second channel is 0 to +5 volts, enter

```
[-10,5]
```

Reset vector

The reset vector controls the behavior of the channel at model termination. Enter a scalar or a vector that is the same length as the channel vector. If you specify a scalar value, that setting is replicated over the channel vector. If you specify a value of 1, the corresponding channel is reset to the value specified in the initial value vector. If you specify a value of 0, the channel remains at the last value attained while the model was running.

Initial value vector

The initial value vector contains the initial voltage values for the output channels. Enter a scalar or a vector that is the same length as the channel vector. If you specify a scalar value, that value is replicated as the initial value over the channel vector. The channels are set to the initial values between the time the model is downloaded and the time it is started.

Sample time

Enter the base sample time or a multiple of the base sample time (-1 means sample time is inherited).

PCI slot (-1:autosearch)

If only one board of this type is in the target computer, enter -1 to locate the board.

If two or more boards of this type are in the target computer, enter the bus number and the PCI slot number of the board associated with this driver block. Use the format [**BusNumber**,**SlotNumber**].

To determine the bus number and the PCI slot number, type:

```
tg = slrt;
getPCIInfo(tg, 'installed')
```

Measurement Computing PCI-DAS 1602/16 Digital Input

PCI-DAS 1602/16 Digital Input block (not recommended)

Library

Simulink Real-Time Library of Drivers No Longer Recommended for Use

Note

The DAS1601/16 has an 8255 chip with 3 ports (A,B,C). Each port has a maximum of 8 digital I/O lines that can be configured as inputs or outputs.

Use a separate driver block for each port. By selecting the digital input driver block, the port is configured as input.

Scaling of Input to Output

I/O Module Input	Block Output Data Type	Scaling
TTL	Double	TTL low = 0.0 TTL high = 1.0

Block Parameters

Channel vector

Enter numbers between 1 and 8 to select the digital input lines used with this port. This driver allows the selection of individual digital input lines in arbitrary order. The number of elements defines the number of digital lines used.

For example, to use all of the digital inputs for one port, enter

```
[1,2,3,4,5,6,7,8]
```

Number the lines beginning with 1 even if this board manufacturer numbers the lines beginning with 0.

Port

From the list choose either A, B, or C. The I/O board has an 8255 chip with 3 ports. The port name defines which port of the 8255 chip is used for this driver block. Each port has a maximum of 8 digital lines that can be configured as inputs or outputs depending on which driver block is chosen. In each case, one block is required for each port.

Sample time

Enter the base sample time or a multiple of the base sample time (- 1 means sample time is inherited).

PCI slot (-1:autosearch)

If only one board of this type is in the target computer, enter - 1 to locate the board.

If two or more boards of this type are in the target computer, enter the bus number and the PCI slot number of the board associated with this driver block. Use the format **[BusNumber,SlotNumber]**.

To determine the bus number and the PCI slot number, type:

```
tg = slrt;  
getPCIInfo(tg, 'installed')
```

Measurement Computing PCI-DAS1602/16 Digital Output

PCI-DAS1602/16 Digital Output block (not recommended)

Library

Simulink Real-Time Library of Drivers No Longer Recommended for Use

Note

The DAS1602/16 has an 8255 chip with 3 ports (A,B,C). Each port has a maximum of 8 digital I/O lines that can be configured as inputs or outputs.

Use a separate driver block for each port. By selecting the digital output driver block, the port is configured as output.

Scaling of Input to Output

I/O Module Output	Block Input Data Type	Scaling
TTL	Double	< 0.5 = TTL low > 0.5 = TTL high

Block Parameters

Channel vector

Enter numbers between 1 and 8 to select the digital output lines used with this port. This driver allows the selection of individual digital output lines in arbitrary order. The number of elements defines the number of digital lines used.

For example, to use all of the digital outputs for one port, enter

```
[1,2,3,4,5,6,7,8]
```

Number the lines beginning with 1 even if this board manufacturer numbers the lines beginning with 0.

Port

From the list choose either A, B, or C. The I/O board has an 8255 chip with 3 ports. The port name defines which port of the 8255 chip is used for this driver block. Each port has a maximum of 8 digital lines that can be configured as inputs or outputs depending on which driver block is chosen. In each case, one block is required for each port.

Reset vector

The reset vector controls the behavior of the channel at model termination. Enter a scalar or a vector that is the same length as the channel vector. If you specify a scalar value, that setting is replicated over the channel vector. If you specify a value of 1, the corresponding channel is reset to the value specified in the initial value vector. If you specify a value of 0, the channel remains at the last value attained while the model was running.

Initial value vector

The initial value vector contains the initial values (0 or 1) of the output channels. Enter a scalar or a vector that is the same length as the channel vector. If you enter a scalar, that value is replicated as the initial value over the channel vector. The channels are set to these initial values between the time the model is downloaded and the time it is started.

Sample time

Enter the base sample time or a multiple of the base sample time (-1 means sample time is inherited).

PCI slot (-1:autosearch)

If only one board of this type is in the target computer, enter -1 to locate the board.

If two or more boards of this type are in the target computer, enter the bus number and the PCI slot number of the board associated with this driver block. Use the format [**BusNumber,SlotNumber**].

To determine the bus number and the PCI slot number, type:

```
tg = slrt;  
getPCIInfo(tg, 'installed')
```

National Instruments Drivers No Longer Recommended for Use

National Instruments PCI-6030E (formerly PCI-MIO-16XE-10)	Support for National Instruments PCI-6030E board
National Instruments PCI-6030E Analog Input (A/D) (formerly PCI-MIO-16XE-10)	PCI-6030E Analog Input block
National Instruments PCI-6030E Analog Output (D/A) (formerly PCI-MIO-16XE-10)	PCI-6030E Analog Output block
National Instruments PCI-6030E Digital Input (formerly PCI-MIO-16XE-10)	PCI-6030E Digital Input block
National Instruments PCI-6030E Digital Output (formerly PCI-MIO-16XE-10)	PCI-6030E Digital Output block
National Instruments PCI-6030E Pulse Generation (formerly PCI-MIO-16XE-10)	PCI-6030E Pulse Generation block
National Instruments PCI-6030E Pulse Width/Period Measurement (formerly PCI-MIO-16XE-10)	PCI-6030E Pulse Width/Period Measurement
National Instruments PCI-6031E	Support for National Instruments PCI-6031E board
National Instruments PCI-6031E Analog Input (A/D)	PCI-6031E Analog Input block
National Instruments PCI-6031E Analog Output (D/A)	PCI-6031E Analog Output block
National Instruments PCI-6031E Digital Input	PCI-6031E Digital Input block
National Instruments PCI-6031E Digital Output	PCI-6031E Digital Output block
National Instruments PCI-6031E Pulse Generation	PCI-6031E Pulse Generation
National Instruments PCI-6031E Pulse Width/Period Measurement	PCI-6031E Pulse Width/Period Measurement block

National Instruments PCI-6030E (formerly PCI-MIO-16XE-10)

Support for National Instruments PCI-6030E board

Board

National Instruments PCI-6030E

General Description

This board was formerly PCI-MIO-16XE-10.

The PCI-6030E is an I/O board with 16 single or 8 differential analog input (A/D) channels (16-bit) with a maximum sample rate of 100 kHz, 2 analog output (D/A) channels (16-bit), 8 digital input and output lines, and 2 counter/timers (24-bit) with a maximum source clock rate of 20 MHz.

The Simulink Real-Time block library supports this board with these driver blocks:

- National Instruments PCI-6030E Analog Input (A/D) (formerly PCI-MIO-16XE-10)
- National Instruments PCI-6030E Analog Output (D/A) (formerly PCI-MIO-16XE-10)
- National Instruments PCI-6030E Digital Input (formerly PCI-MIO-16XE-10)
- National Instruments PCI-6030E Digital Output (formerly PCI-MIO-16XE-10)
- National Instruments PCI-6030E Pulse Generation (formerly PCI-MIO-16XE-10)
- National Instruments PCI-6030E Pulse Width/Period Measurement (formerly PCI-MIO-16XE-10)

Board Characteristics

Board name	PCI-6030E
Manufacturer	National Instruments
Bus type	PCI

Access method

Multiple block instance support

Multiple board support

I/O mapped

A/D: No, D/A: No, Digital I/O: Yes; Pulse

Width/Period measurement: Yes; Pulse

Train Generation: No

Yes

National Instruments PCI-6030E Analog Input (A/D) (formerly PCI-MIO-16XE-10)

PCI-6030E Analog Input block

Library

Simulink Real-Time Library of Drivers No Longer Recommended for Use

Scaling of Input to Output

Hardware Input	Block Output Data Type	Scaling
Volts	Double	1

Block Parameters

Channel vector

Enter numbers between 1 and 16. This driver allows you to enter channel numbers in arbitrary order.

For example, to use the first, second, and fifth channels, enter

```
[1,2,5]
```

Number the channels beginning with 1, even if this board manufacturer starts numbering the channels with 0.

Range vector

Enter a range code for each of the channels in the channel vector. The range vector must be the same length as the channel vector. This driver allows each channel to be different.

The following table is a list of the ranges for this driver and the corresponding range codes.

Input Range (V)	Range Code
-10 to +10	-10
-5 to +5	-5
-2 to +2	-2
-1 to +1	-1
-0.5 to +0.5	-0.5
-0.2 to +0.2	-0.2
-0.1 to +0.1	-0.1
0 to +10	10
0 to +5	5
0 to +2	2
0 to +1	1
0 to +0.5	0.5
0 to +0.2	0.2
0 to +0.1	0.1

For example, if the first channel is -10 to +10 volts and the second and fifth channels are 0 to +1 volts, enter

[-10, 1, 1]

Input coupling vector

Enter a coupling code for each of the channels in the channel vector. The coupling vector must be the same length as the channel vector. This driver allows a different coupling for each channel.

The following table is a list of the couplings for this driver and the corresponding coupling codes.

Coupling	Coupling Code	Description
RSE	0	Analog input line connected to the positive input of the PGIA. Analog input ground (AIGND) internally connected to the negative input of the PGIA. See the board manual.

Coupling	Coupling Code	Description
NRSE	1	Analog input line connected to the positive input of the PGIA. Analog input sense (AISENSE) connected to the negative input of the PGIA. See the board manual.
DIFF	2	First analog input line connected to the positive input of the PGIA. Second analog input line connected to the negative input of the PGIA. See the board manual.

For example, if the first and second channels are single input and the fifth channel is a differential input, enter

```
[0,0,2]
```

The driver selects a second differential input 8 channels higher than the first channel. In the example above, the driver would select the thirteenth channel as a differential input with the fifth channel.

If the board is set up for differential mode, you can read the data from either of the channels in the differential pair. For example, if you have a differential pair of 1 and 9, you can read the data from channel 1 or channel 9. However, you might want to read the lower channel number of the pair because it remains unchanged when you switch the input mode between single-ended and differential.

Sample time

Enter the base sample time or a multiple of the base sample time (- 1 means sample time is inherited).

PCI slot (-1:autosearch)

If only one board of this type is in the target computer, enter - 1 to locate the board.

If two or more boards of this type are in the target computer, enter the bus number and the PCI slot number of the board associated with this driver block. Use the format **[BusNumber,SlotNumber]**.

To determine the bus number and the PCI slot number, type:

```
tg = slrt;
getPCIInfo(tg, 'installed')
```

National Instruments PCI-6030E Analog Output (D/A) (formerly PCI-MIO-16XE-10)

PCI-6030E Analog Output block

Library

Simulink Real-Time Library of Drivers No Longer Recommended for Use

Note

The analog output range of this board is set -10 to +10 volts.

Scaling of Input to Output

Hardware Output	Block Input Data Type	Scaling
Volts	Double	1

Block Parameters

Channel vector

Enter 1 or 2. This driver allows the selection of individual D/A channels in arbitrary order. The number of elements defines the number of D/A channels used. For example, to use both of the analog output channels, enter

[1,2]

Number the channels begin with 1 even if this board manufacturer starts numbering the channels with 0.

Range vector

Enter a range code for each of the channels in the channel vector. The range vector must be the same length as the channel vector. This board allows the range of each channel to be different.

The following table is a list of the ranges for this driver and the corresponding range codes.

Input Range (V)	Range Code
-10 to +10	-10
0 to +10	10

For example, if the first channel is -10 to +10 volts and the second channel is 0 to +10 volts, enter

`[-10,10]`

Reset vector

The reset vector controls the behavior of the channel at model termination. Enter a scalar or a vector that is the same length as the channel vector. If you specify a scalar value, that setting is replicated over the channel vector. If you specify a value of 1, the corresponding channel is reset to the value specified in the initial value vector. If you specify a value of 0, the channel remains at the last value attained while the model was running.

Initial value vector

The initial value vector contains the initial voltage values for the output channels. Enter a scalar or a vector that is the same length as the channel vector. If you specify a scalar value, that value is replicated as the initial value over the channel vector. The channels are set to the initial values between the time the model is downloaded and the time it is started.

Sample time

Enter the base sample time or a multiple of the base sample time (-1 means sample time is inherited).

PCI slot (-1:autosearch)

If only one board of this type is in the target computer, enter -1 to locate the board.

If two or more boards of this type are in the target computer, enter the bus number and the PCI slot number of the board associated with this driver block. Use the format **[BusNumber,SlotNumber]**.

To determine the bus number and the PCI slot number, type:

```
tg = slrt;
getPCIInfo(tg, 'installed')
```

National Instruments PCI-6030E Digital Input (formerly PCI-MIO-16XE-10)

PCI-6030E Digital Input block

Library

Simulink Real-Time Library of Drivers No Longer Recommended for Use

Scaling of Input to Output

Hardware Input	Block Output Data Type	Scaling
TTL	Double	TTL low = 0.0 TTL high = 1.0

Block Parameters

Channel vector

Enter numbers between 1 and 8 to select the digital input lines used with this port. This driver allows the selection of individual digital input lines in arbitrary order. The number of elements defines the number of digital lines used.

For example, to use all of the digital inputs for one port, enter

```
[1,2,3,4,5,6,7,8]
```

Number the lines beginning with 1 even if this board manufacturer starts numbering the lines with 0.

Sample time

Enter the base sample time or a multiple of the base sample time (-1 means sample time is inherited).

PCI slot (-1:autosearch)

If only one board of this type is in the target computer, enter -1 to locate the board.

If two or more boards of this type are in the target computer, enter the bus number and the PCI slot number of the board associated with this driver block. Use the format **[BusNumber,SlotNumber]**.

To determine the bus number and the PCI slot number, type:

```
tg = slrt;  
getPCIInfo(tg, 'installed')
```

National Instruments PCI-6030E Digital Output (formerly PCI-MIO-16XE-10)

PCI-6030E Digital Output block

Library

Simulink Real-Time Library of Drivers No Longer Recommended for Use

Scaling of Input to Output

Hardware Output	Block Input Data Type	Scaling
TTL	Double	< 0.5 = TTL low ≥ 0.5 = TTL high

Block Parameters

Channel vector

Enter numbers between 1 and 8 to select the digital output lines used with this port. This driver allows the selection of individual digital output lines in arbitrary order. The number of elements defines the number of digital lines used.

For example, to use all of the digital outputs for one port, enter

```
[1,2,3,4,5,6,7,8]
```

Number the lines beginning with 1 even if this board manufacturer starts numbering the lines with 0.

Reset vector

The reset vector controls the behavior of the channel at model termination. Enter a scalar or a vector that is the same length as the channel vector. If you specify a scalar value, that setting is replicated over the channel vector. If you specify a value of 1, the corresponding channel is reset to the value specified in the initial value vector.

If you specify a value of 0, the channel remains at the last value attained while the model was running.

Initial value vector

The initial value vector contains the initial values (0 or 1) of the output channels. Enter a scalar or a vector that is the same length as the channel vector. If you enter a scalar, that value is replicated as the initial value over the channel vector. The channels are set to these initial values between the time the model is downloaded and the time it is started.

Sample time

Enter the base sample time or a multiple of the base sample time (- 1 means sample time is inherited).

PCI slot (-1:autosearch)

If only one board of this type is in the target computer, enter - 1 to locate the board.

If two or more boards of this type are in the target computer, enter the bus number and the PCI slot number of the board associated with this driver block. Use the format **[BusNumber, SlotNumber]**.

To determine the bus number and the PCI slot number, type:

```
tg = slrt;  
getPCIInfo(tg, 'installed')
```

National Instruments PCI-6030E Pulse Generation (formerly PCI-MIO-16XE-10)

PCI-6030E Pulse Generation block

Library

Simulink Real-Time Library of Drivers No Longer Recommended for Use

Note

The inputs to the block should be a two-element vector. The first element is the number of counts (of the 20 MHz source clock) that the counter should maintain at a low level, and the second element is the number of clock ticks for a high level. For example, to generate a pulse train at 1 kHz with 25% low and 75% high, use the vector

```
[5000 15000]
```

Block Parameters

Counter

From the list, choose **Counter 0**, **Counter 1**, or **Both** to select the counter(s) to be used with this driver block. In each case, one block is required for each physical board.

Sample time

Enter the base sample time or a multiple of the base sample time (-1 means sample time is inherited).

PCI slot (-1:autosearch)

If only one board of this type is in the target computer, enter -1 to locate the board.

If two or more boards of this type are in the target computer, enter the bus number and the PCI slot number of the board associated with this driver block. Use the format **[BusNumber, SlotNumber]**.

To determine the bus number and the PCI slot number, type:

```
tg = slrt;  
getPCIInfo(tg, 'installed')
```

National Instruments PCI-6030E Pulse Width/Period Measurement (formerly PCI-MIO-16XE-10)

PCI-6030E Pulse Width/Period Measurement

Library

Simulink Real-Time Library of Drivers No Longer Recommended for Use

Note

Connect the signal you want to measure to the GATE input of the chosen counter. The signal must have fast rise and fall times; otherwise, the counter might experience false triggering. Use signal voltage levels between 0 and 5 volts (TTL levels).

Block Parameters

Counter

From the list, select a counter, 0 or 1.

Trigger mode

From the list, choose **Level Triggered** or **Edge Triggered**. See the table below for an example of how **Trigger mode** and **Polarity** interact. In this table, the data in the Output column resulted from a 1 kHz pulse train with a 25% low and a 75% high pulse.

Polarity

From the list, choose **Active low** or **Active high**. See the table below for an example of how **Trigger mode** and **Polarity** interact. In this table, the data in the Output column resulted from a 1 kHz pulse train with a 25% low and a 75% high pulse.

Measurement Objective	Trigger Mode	Polarity	Output
Pulse width (low pulse)	Level triggered	Active low	5000

Measurement Objective	Trigger Mode	Polarity	Output
Pulse width (high pulse)	Level triggered	Active high	15000
Period	Edge triggered	NA	20000

In every case, the output of the block is the number of clock ticks (of the 20 MHz source clock) required for the specified measurement. When measuring pulse width, the output reflects the number of clock ticks for which the input signal was in the specified (low or high) state. See the table above for an example.

Sample time

Enter the base sample time or a multiple of the base sample time (- 1 means sample time is inherited).

PCI slot (-1:autosearch)

If only one board of this type is in the target computer, enter - 1 to locate the board.

If two or more boards of this type are in the target computer, enter the bus number and the PCI slot number of the board associated with this driver block. Use the format **[BusNumber,SlotNumber]**.

To determine the bus number and the PCI slot number, type:

```
tg = slrt;  
getPCIInfo(tg, 'installed')
```

National Instruments PCI-6031E

Support for National Instruments PCI-6031E board

Board

National Instruments PCI-6031E

General Description

The PCI-6031E is an I/O board with 64 single or 32 differential analog input (A/D) channels (16-bit) with a maximum sample rate of 100 kHz, 2 analog output (D/A) channels (16-bit), 8 digital input and output lines, and 2 counter/timers (24-bit) with a maximum source clock rate of 20 MHz.

The Simulink Real-Time block library supports this board with these driver blocks:

- National Instruments PCI-6031E Analog Input (A/D)
- National Instruments PCI-6031E Analog Output (D/A)
- National Instruments PCI-6031E Digital Input
- National Instruments PCI-6031E Digital Output
- National Instruments PCI-6031E Pulse Generation
- National Instruments PCI-6031E Pulse Width/Period Measurement

Board Characteristics

Board name	PCI-6031E
Manufacturer	National Instruments
Bus type	PCI
Access method	Memory mapped
Multiple block instance support	A/D: No, D/A: No, Digital I/O: Yes; Pulse Width/Period measurement: Yes; Pulse Train Generation: No

Multiple board support

Yes

National Instruments PCI-6031E Analog Input (A/D)

PCI-6031E Analog Input block

Library

Simulink Real-Time Library of Drivers No Longer Recommended for Use

Scaling of Input to Output

Hardware Input	Block Output Data Type	Scaling
Volts	Double	1

Block Parameters

Channel vector

Enter numbers between 1 and 64. This driver allows you to enter channel numbers in arbitrary order.

For example, to use the first, second, and fifth channels, enter

[1,2,5]

Number the channels beginning with 1, even if this board manufacturer starts numbering the channels with 0.

Range vector

Enter a range code for each of the channels in the channel vector. The range vector must be the same length as the channel vector. This driver allows each channel to be different.

The following table is a list of the ranges for this driver and the corresponding range codes.

Input Range (V)	Range Code
-10 to +10	-10
-5 to +5	-5

Input Range (V)	Range Code
-2 to +2	-2
-1 to +1	-1
-0.5 to +0.5	-0.5
-0.2 to +0.2	-0.2
-0.1 to +0.1	-0.1
0 to +10	10
0 to +5	5
0 to +2	2
0 to +1	1
0 to +0.5	0.5
0 to +0.2	0.2
0 to +0.1	0.1

For example, if the first channel is -10 to +10 volts and the second and fifth channels are 0 to +1 volts, enter

`[-10, 1, 1]`

Input coupling vector

Enter a coupling code for each of the channels in the channel vector. The coupling vector must be the same length as the channel vector. This driver allows a different coupling for each channel.

The following table is a list of the couplings for this driver and the corresponding coupling codes.

Coupling	Coupling Code	Description
RSE	0	Analog input line connected to the positive input of the PGIA. Analog input ground (AIGND) internally connected to the negative input of the PGIA. See the board manual.
NRSE	1	Analog input line connected to the positive input of the PGIA. Analog input sense (AISENSE) connected to the negative input of the PGIA. See the board manual.

Coupling	Coupling Code	Description
DIFF	2	First analog input line connected to the positive input of the PGIA. Second analog input line connected to the negative input of the PGIA. See the board manual.

For example, if the first and second channels are single input and the fifth channel is a differential input, enter

```
[0,0,2]
```

The driver selects a second differential input 8 channels higher than the first channel. In the example above, the driver would select the thirteenth channel as a differential input with the fifth channel.

If the board is set up for differential mode, you can read the data from either of the channels in the differential pair. For example, if you have a differential pair of 1 and 9, you can read the data from channel 1 or channel 9. However, you might want to read the lower channel number of the pair because it remains unchanged when you switch the input mode between single-ended and differential.

Sample time

Enter the base sample time or a multiple of the base sample time (- 1 means sample time is inherited).

PCI slot (-1:autosearch)

If only one board of this type is in the target computer, enter - 1 to locate the board.

If two or more boards of this type are in the target computer, enter the bus number and the PCI slot number of the board associated with this driver block. Use the format [**BusNumber**, **SlotNumber**].

To determine the bus number and the PCI slot number, type:

```
tg = slrt;
getPCIInfo(tg, 'installed')
```

National Instruments PCI-6031E Analog Output (D/A)

PCI-6031E Analog Output block

Library

Simulink Real-Time Library of Drivers No Longer Recommended for Use

Note

The analog output range of this board is set -10 to +10 volts.

Scaling of Input to Output

Hardware Output	Block Input Data Type	Scaling
Volts	Double	1

Block Parameters

Channel vector

Enter 1 or 2. This driver allows the selection of individual D/A channels in arbitrary order. The number of elements defines the number of D/A channels used. For example, to use both of the analog output channels, enter

[1,2]

Number the channels begin with 1 even if this board manufacturer starts numbering the channels with 0.

Range vector

Enter a range code for each of the channels in the channel vector. The range vector must be the same length as the channel vector. This board allows the range of each channel to be different.

The following table is a list of the ranges for this driver and the corresponding range codes.

Input Range (V)	Range Code
-10 to +10	-10
0 to +10	10

For example, if the first channel is -10 to +10 volts and the second channel is 0 to +10 volts, enter

```
[ -10, 10]
```

Reset vector

The reset vector controls the behavior of the channel at model termination. Enter a scalar or a vector that is the same length as the channel vector. If you specify a scalar value, that setting is replicated over the channel vector. If you specify a value of 1, the corresponding channel is reset to the value specified in the initial value vector. If you specify a value of 0, the channel remains at the last value attained while the model was running.

Initial value vector

The initial value vector contains the initial voltage values for the output channels. Enter a scalar or a vector that is the same length as the channel vector. If you specify a scalar value, that value is replicated as the initial value over the channel vector. The channels are set to the initial values between the time the model is downloaded and the time it is started.

Sample time

Enter the base sample time or a multiple of the base sample time (- 1 means sample time is inherited).

PCI slot (-1:autosearch)

If only one board of this type is in the target computer, enter - 1 to locate the board.

If two or more boards of this type are in the target computer, enter the bus number and the PCI slot number of the board associated with this driver block. Use the format **[BusNumber, SlotNumber]**.

To determine the bus number and the PCI slot number, type:

```
tg = slrt;
getPCIInfo(tg, 'installed')
```

National Instruments PCI-6031E Digital Input

PCI-6031E Digital Input block

Library

Simulink Real-Time Library of Drivers No Longer Recommended for Use

Scaling of Input to Output

Hardware Input	Block Output Data Type	Scaling
TTL	Double	TTL low = 0.0 TTL high = 1.0

Block Parameters

Channel vector

Enter numbers between 1 and 8 to select the digital input lines used with this port. This driver allows the selection of individual digital input lines in arbitrary order. The number of elements defines the number of digital lines used.

For example, to use all of the digital inputs for one port, enter

```
[1,2,3,4,5,6,7,8]
```

Number the lines beginning with 1 even if this board manufacturer starts numbering the lines with 0.

Sample time

Enter the base sample time or a multiple of the base sample time (-1 means sample time is inherited).

PCI slot (-1:autosearch)

If only one board of this type is in the target computer, enter -1 to locate the board.

If two or more boards of this type are in the target computer, enter the bus number and the PCI slot number of the board associated with this driver block. Use the format **[BusNumber,SlotNumber]**.

To determine the bus number and the PCI slot number, type:

```
tg = slrt;  
getPCIInfo(tg, 'installed')
```

National Instruments PCI-6031E Digital Output

PCI-6031E Digital Output block

Library

Simulink Real-Time Library of Drivers No Longer Recommended for Use

Scaling of Input to Output

Hardware Output	Block Input Data Type	Scaling
TTL	Double	$< 0.5 = \text{TTL low}$ $\geq 0.5 = \text{TTL high}$

Block Parameters

Channel vector

Enter numbers between 1 and 8 to select the digital output lines used with this port. This driver allows the selection of individual digital output lines in arbitrary order. The number of elements defines the number of digital lines used.

For example, to use all of the digital outputs for one port, enter

```
[1,2,3,4,5,6,7,8]
```

Number the lines beginning with 1 even if this board manufacturer starts numbering the lines with 0.

Reset vector

The reset vector controls the behavior of the channel at model termination. Enter a scalar or a vector that is the same length as the channel vector. If you specify a scalar value, that setting is replicated over the channel vector. If you specify a value of 1, the corresponding channel is reset to the value specified in the initial value vector. If you specify a value of 0, the channel remains at the last value attained while the model was running.

Initial value vector

The initial value vector contains the initial values (0 or 1) of the output channels. Enter a scalar or a vector that is the same length as the channel vector. If you enter a scalar, that value is replicated as the initial value over the channel vector. The channels are set to these initial values between the time the model is downloaded and the time it is started.

Sample time

Enter the base sample time or a multiple of the base sample time (-1 means sample time is inherited).

PCI slot (-1:autosearch)

If only one board of this type is in the target computer, enter -1 to locate the board.

If two or more boards of this type are in the target computer, enter the bus number and the PCI slot number of the board associated with this driver block. Use the format **[BusNumber,SlotNumber]**.

To determine the bus number and the PCI slot number, type:

```
tg = slrt;  
getPCIInfo(tg, 'installed')
```

National Instruments PCI-6031E Pulse Generation

PCI-6031E Pulse Generation

Library

Simulink Real-Time Library of Drivers No Longer Recommended for Use

Note

The inputs to the block should be a two-element vector. The first element is the number of counts (of the 20 MHz source clock) that the counter should maintain at a low level, and the second element is the number of clock ticks for a high level. For example, to generate a pulse train at 1 kHz with 25% low and 75% high, use the vector

```
[5000 15000]
```

Block Parameters

Counter

From the list, choose **Counter 0**, **Counter 1**, or **Both** to select the counter(s) to be used with this driver block. In each case, one block is required for each physical board.

Sample time

Enter the base sample time or a multiple of the base sample time (- 1 means sample time is inherited).

PCI slot (-1:autosearch)

If only one board of this type is in the target computer, enter - 1 to locate the board.

If two or more boards of this type are in the target computer, enter the bus number and the PCI slot number of the board associated with this driver block. Use the format **[BusNumber, SlotNumber]**.

To determine the bus number and the PCI slot number, type:

```
tg = slrt;  
getPCIInfo(tg, 'installed')
```

National Instruments PCI-6031E Pulse Width/Period Measurement

PCI-6031E Pulse Width/Period Measurement block

Library

Simulink Real-Time Library of Drivers No Longer Recommended for Use

Note

Connect the signal you want to measure to the GATE input of the chosen counter. The signal must have fast rise and fall times; otherwise, the counter might experience false triggering. Use signal voltage levels between 0 and 5 volts (TTL levels).

Block Parameters

Counter

From the list, select a counter, 0 or 1.

Trigger mode

From the list, choose **Level Triggered** or **Edge Triggered**. See the table below for an example of how **Trigger mode** and **Polarity** interact. In this table, the data in the Output column resulted from a 1 kHz pulse train with a 25% low and a 75% high pulse.

Polarity

From the list, choose **Active low** or **Active high**. See the table below for an example of how **Trigger mode** and **Polarity** interact. In this table, the data in the Output column resulted from a 1 kHz pulse train with a 25% low and a 75% high pulse.

Measurement Objective	Trigger Mode	Polarity	Output
Pulse width (low pulse)	Level triggered	Active low	5000

Measurement Objective	Trigger Mode	Polarity	Output
Pulse width (high pulse)	Level triggered	Active high	15000
Period	Edge triggered	NA	20000

In every case, the output of the block is the number of clock ticks (of the 20 MHz source clock) required for the specified measurement. When measuring pulse width, the output reflects the number of clock ticks for which the input signal was in the specified (low or high) state. See the table above for an example.

Sample time

Enter the base sample time or a multiple of the base sample time (- 1 means sample time is inherited).

PCI slot (-1:autosearch)

If only one board of this type is in the target computer, enter - 1 to locate the board.

If two or more boards of this type are in the target computer, enter the bus number and the PCI slot number of the board associated with this driver block. Use the format [**BusNumber**, **SlotNumber**].

To determine the bus number and the PCI slot number, type:

```
tg = slrt;
getPCIInfo(tg, 'installed')
```

Real Time Devices Drivers No Longer Recommended for Use

Real Time Devices DM6804	Real Time Devices DM6804 board (not recommended)
Real Time Devices DM6804 Counter PWM	DM6804 Counter PWM block (not recommended)
Real Time Devices DM6804 Counter PWM & ARM	DM6804 Counter PWM & ARM block (not recommended)
Real Time Devices DM6804 Counter FM	DM6804 Counter FM block (not recommended)
Real Time Devices DM6804 Counter FM & ARM	DM6804 Counter FM & ARM block (not recommended)
Real Time Devices DM6804 PWM Capture	DM6804 PWM Capture block (not recommended)
Real Time Devices DM6804 FM Capture	DM6804 FM Capture block (not recommended)
Real Time Devices DM6804xx	DM6804xx block (not recommended)
Real Time Devices DM7420	Support for the RTD DM7420 I/O board (not recommended)
Real Time Devices DM7420 Analog Input (A/D)	DM7420 Analog Input block (not recommended)
Real Time Devices DM7420 Digital Input	DM7420 Digital Input block (not recommended)
Real Time Devices DM7420 Digital Output	DM7420 Digital Output block (not recommended)

Real Time Devices DM6804

Real Time Devices DM6804 board (not recommended)

Board

Real Time Devices DM6804

General Description

The DM6804 is an ISA PC/104 I/O board with 24 digital I/O lines and 5 counter/timer channels (16-bit).

It contains one 8255 chip with 3 digital I/O ports and one AM9513A counter/timer chip. For additional information about the various counter/timer modes of that chip see the AM9513A data sheet which is part of the board documentation.

The Simulink Real-Time product supports this board with these driver blocks:

- Real Time Devices DM6804 Counter PWM
- Real Time Devices DM6804 Counter PWM & ARM
- Real Time Devices DM6804 Counter FM
- Real Time Devices DM6804 Counter FM & ARM
- Real Time Devices DM6804 PWM Capture
- Real Time Devices DM6804 FM Capture
- Real Time Devices DM6804xx

Board Characteristics

Board name	DM6804
Manufacturer	Real Time Devices
Bus type	ISA
Access method	I/O mapped

Multiple block instance support	Yes
Multiple board support	Yes

Real Time Devices DM6804 Counter PWM

DM6804 Counter PWM block (not recommended)

Library

Simulink Real-Time Library of Drivers No Longer Recommended for Use

Note

The DM6804 has one AM9513A chip with 5 counters.

The DM6804 PWM driver programs the AM9513A for PWM (Pulse Width Modulation) signal generation (a square wave with fixed frequency and variable duty cycle). The block has one input which defines the variable duty cycle between 0 and 1. For the corresponding counter channel, the PWM signal is output at the pin named OUT.

Scaling Input to Output

Hardware Output	Block Input Data Type	Scaling
TTL	Double	0 to 1

Block Parameters

Counter

From the list, choose 1, 2, 3, 4, or 5 to select which counter is used with this driver block. One block is required for each counter used.

Frequency base

From the list, choose F1=5MHz, F2=500kHz, F3=50kHz, F4=5kHz, or F5=500Hz to set the base frequency.

Relative output frequency

Enter a value between 0 and 0.25. The **Relative output frequency** is multiplied by the **Frequency base** to set the fixed output frequency of the PWM-signal.

For example, if the output frequency of a square wave has to be 87.5 kHz, then choose $F_2=500\text{kHz}$ as the **Frequency base** and enter 0.175 as the **Relative output frequency**. $500\text{ kHz} \times 0.175 = 87.5\text{ kHz}$

Level sequence of square wave

From the list, choose either **high-low** or **low-high**:

- If you choose **high-low**, the square wave period starts with the TTL high part followed by the TTL low part.
- If you choose **low-high**, the square wave period starts with the TTL low part followed by the TTL high part.

In either case, the duty cycle entering the block defines the duration of the TTL high part.

Level when disarmed

From the list, choose either **high** or **low**. The counter is automatically disarmed when the real-time application is not running and gets armed when the application begins running. This parameter sets the TTL level when the counter is disarmed.

Sample time

Enter the base sample time or a multiple of the base sample time. The sample time indicates the update rate of registration on the input (Duty Cycle)

Base address

Enter the base address of the board. This entry must correspond to the DIP switch setting on the board. For example, if the DIP switch setting is 300 (hexadecimal), enter 0x300.

Real Time Devices DM6804 Counter PWM & ARM

DM6804 Counter PWM & ARM block (not recommended)

Library

Simulink Real-Time Library of Drivers No Longer Recommended for Use

Note

The DM6804 has one AM9513A chip with 5 counters.

The DM6804 PWM & ARM driver programs the AM9513A for PWM or disarmed signal generation (a square wave with fixed frequency and variable duty cycle). Additionally the driver allows to arm and disarm the counter by the second block input. For the corresponding counter channel, the PWM signal is output at the pin named OUT.

Scaling Input to Output

Hardware Output	Block Input Data Type	Scaling
TTL	Duty cycle: Double Arm: Double	0 to 1 <0.5 disarmed ≥0.5 armed

Block Parameters

Counter

From the list, choose 1, 2, 3, 4, or 5 to select which counter is used with this driver block. One block is required for each counter used.

Frequency base

From the list, choose F1=5MHz, F2=500kHz, F3=50kHz, F4=5kHz, or F5=500Hz to set the base frequency.

Relative output frequency

Enter a value between 0 and 0.25. The **Relative output frequency** is multiplied by the **Frequency base** to set the fixed output frequency of the PWM-signal.

For example, if the output frequency of a square wave has to be 87.5 kHz, then choose $F_2=500\text{kHz}$ as the **Frequency base** and enter 0.175 as the **Relative output frequency**. $500\text{ kHz} \times 0.175 = 87.5\text{ kHz}$

Level sequence of square wave

From the list, choose either **high-low** or **low-high**:

- If you choose **high-low**, the square wave period starts with the TTL high part followed by the TTL low part.
- If you choose **low-high**, the square wave period starts with the TTL low part followed by the TTL high part.

In either case, the duty cycle entering the block defines the duration of the TTL high part.

Level when disarmed

From the list, choose either **high** or **low**. The counter is automatically disarmed when the real-time application is not running. If the application is running, the second input port controls whether the counter is armed or disarmed. This parameter sets the TTL level when the counter is disarmed.

Sample time

Enter the base sample time or a multiple of the base sample time. The sample time indicates the update rate of registration on the input (Duty Cycle)

Base address

Enter the base address of the board. This entry must correspond to the DIP switch setting on the board. For example, if the DIP switch setting is 300 (hexadecimal), enter 0x300.

Real Time Devices DM6804 Counter FM

DM6804 Counter FM block (not recommended)

Library

Simulink Real-Time Library of Drivers No Longer Recommended for Use

Note

The DM6804 has one AM9513A chip with 5 counters.

The DM6804 FM driver programs the AM9513A for FM (Frequency Modulation) signal generation (a square wave with fixed duty cycle and variable frequency). For the corresponding counter channel, the PWM signal is output at the pin named OUT.

Scaling Input to Output

Hardware Output	Block Input Data Type	Scaling
TTL	Double	0 to 1

Block Parameters

Counter

From the list, choose 1, 2, 3, 4, or 5 to select which counter is used with this driver block. One block is required for each counter used.

Frequency base

From the list, choose F1=5MHz, F2=500kHz, F3=50kHz, F4=5kHz, or F5=500Hz to set the base frequency.

Output duty cycle

Enter a value between 0 and 1 to set the duty cycle of the square wave. The Duty Cycle is held fixed during execution of the real-time application.

Note: Your control over the output duty cycle is not precise. See “PWM and FM Driver Block Notes” on page 1-9 for details.

Level sequence of square wave

From the list, choose either **high-low** or **low-high**:

- If you choose **high-low**, the square wave period starts with the TTL high part followed by the TTL low part.
- If you choose **low-high**, the square wave period starts with the TTL low part followed by the TTL high part.

In either case, the duty cycle entering the block defines the duration of the TTL high part.

Level when disarmed

From the list, choose either **high** or **low**. The counter is automatically disarmed when the real-time application is not running and gets armed when the application begins running. This parameter sets the TTL level when the counter is disarmed.

Sample time

Enter the base sample time or a multiple of the base sample time. The sample time indicates the update rate of registration on the input (Duty Cycle)

Base address

Enter the base address of the board. This entry must correspond to the DIP switch setting on the board. For example, if the DIP switch setting is 300 (hexadecimal), enter **0x300**.

Real Time Devices DM6804 Counter FM & ARM

DM6804 Counter FM & ARM block (not recommended)

Library

Simulink Real-Time Library of Drivers No Longer Recommended for Use

Note

The DM6804 has one AM9513A chip with 5 counters.

The DM6804 FM & ARM driver programs the AM9513A for FM (Frequency Modulation) signal generation (a square wave with fixed duty cycle and variable frequency). Additionally the driver allows to arm and disarm the counter by the second block input. For the corresponding counter channel, the PWM signal is output at the pin named OUT.

Scaling Input to Output

Hardware Output	Block Input Data Type	Scaling
TTL	Variable frequency: Double Arm: Double	<0.5 disarmed ≥0.5 armed

Block Parameters

Counter

From the list, choose 1, 2, 3, 4, or 5 to select which counter is used with this driver block. One block is required for each counter used.

Frequency base

From the list, choose F1=5MHz, F2=500kHz, F3=50kHz, F4=5kHz, or F5=500Hz to set the base frequency. The XTAL frequency is assumed to be 1 MHz, therefore the jumper on the DM6804 has to be in position 1 MHz not 5 MHz.

Output duty cycle

Enter a value between 0 and 1 to set the duty cycle of the square wave. The Duty Cycle is held fixed during execution of the real-time application.

Note: Your control over the output duty cycle is not precise. See “PWM and FM Driver Block Notes” on page 1-9 for details.

Level sequence of square wave

From the list, choose either **high-low** or **low-high**:

- If you choose **high-low**, the square wave period starts with the TTL high part followed by the TTL low part.
- If you choose **low-high**, the square wave period starts with the TTL low part followed by the TTL high part.

In either case, the **Output duty cycle** defined in the setting above define the duration of the TTL high part.

Level when disarmed

From the list, choose either **high** or **low**. The counter is automatically disarmed when the real-time application is not running. If the application is running, the second input port controls whether the counter is armed or disarmed. This parameter sets the TTL level when the counter is disarmed.

Sample time

Enter the base sample time or a multiple of the base sample time. The sample time indicates the update rate of registration on the input (Duty Cycle)

Base address

Enter the base address of the board. This entry must correspond to the DIP switch setting on the board. For example, if the DIP switch setting is 300 (hexadecimal), enter **0x300**.

Real Time Devices DM6804 PWM Capture

DM6804 PWM Capture block (not recommended)

Library

Simulink Real-Time Library of Drivers No Longer Recommended for Use

Note

This block programs the AMD9513A for capturing PWM signals by using two counters. One counter measures the cycle duration, and the other counter measures the duration the signal is high.

There are two outputs. One output is the relative frequency compared to the base frequency. The other output is the duty cycle. To get the actual frequency, multiply the base frequency by the relative frequency.

The PWM signal has to enter the pins named GATE of both corresponding counter channels (parallel wiring). Both CLK pins have to be left unconnected.

Scaling Input to Output

Hardware Output	Block Input Data Type	Scaling
TTL	Double	0 to 1

Block Parameters

Counter

From the list, choose 1&2, 2&3, 3&4, 4&5. This selects which two counters the driver block uses to determine the PWM. One block is required for each counter used.

Frequency base

From the list, choose F1=5MHz, F2=500kHz, F3=50kHz, F4=5kHz, or F5=500Hz to set the base frequency. The XTAL frequency is assumed to be 1 MHz, therefore the jumper on the DM6804 has to be in position 1 MHz not 5 MHz.

Sample time

Enter the base sample time or a multiple of the base sample time. The sample time indicates the update rate of registration on the input (Duty Cycle)

Base address

Enter the base address of the board. This entry must correspond to the DIP switch setting on the board. For example, if the DIP switch setting is 300 (hexadecimal), enter 0x300.

Real Time Devices DM6804 FM Capture

DM6804 FM Capture block (not recommended)

Library

Simulink Real-Time Library of Drivers No Longer Recommended for Use

Note

This block programs the AMD9513A for capturing FM signals.

There is one output for relative frequency compared to the base frequency. To get the actual frequency, multiply the base frequency by the relative frequency.

The FM signal has to enter the pin named GATE of the corresponding counter channel. The CLK pin has to be left unconnected.

Scaling Input to Output

Hardware Output	Block Input Data Type	Scaling
TTL	Double	0 to 1

Block Parameters

Counter

From the list, choose 1, 2, 3, 4, or 5. This selects which counter the driver block uses to determine the FM. One block is required for each counter used.

Frequency base

From the list, choose F1=5MHz, F2=500kHz, F3=50kHz, F4=5kHz, or F5=500Hz to set the base frequency.

Sample time

Enter the base sample time or a multiple of the base sample time. The sample time indicates the update rate of registration on the input (Duty Cycle)

Base address

Enter the base address of the board. This entry must correspond to the DIP switch setting on the board. For example, if the DIP switch setting is 300 (hexadecimal), enter **0x300**.

Real Time Devices DM6804xx

DM6804xx block (not recommended)

Library

Simulink Real-Time Library of Drivers No Longer Recommended for Use

Description

You can use this block to program the AMD9513A counter. The PWM, PWM & ARM, FM, FM & ARM, PWM Capture, and FM Capture blocks use this block in their underlying subsystems. The API for this block is not currently documented.

Real Time Devices DM7420

Support for the RTD DM7420 I/O board (not recommended)

Board

Real Time Devices DM7420

General Description

The DM7420 is a PCI PC/104 I/O board with 16 single or 8 differential analog input (A/D) channels (12-bit) with a maximum sample rate of 600 kHz, 8 independent digital I/O lines, 8 dependent digital I/O lines, and 9 counter/timers.

The Simulink Real-Time block library supports this board with these driver blocks:

- Real Time Devices DM7420 Analog Input (A/D)
- Real Time Devices DM7420 Digital Input
- Real Time Devices DM7420 Digital Output

Note: The Simulink Real-Time software does not support the counter/timers on this board.

Board Characteristics

Board name	DM6604
Manufacturer	Real Time Devices
Bus type	PCI (PC104)
Access method	I/O mapped
Multiple block instance support	Yes
Multiple board support	Yes

Real Time Devices DM7420 Analog Input (A/D)

DM7420 Analog Input block (not recommended)

Library

Simulink Real-Time Library of Drivers No Longer Recommended for Use

Scaling Input to Output

Hardware Input	Block Output Data Type	Scaling
Volts	Double	1

Block Parameters

Channel vector

Enter numbers between 1 and 16. This driver allows the selection of individual A/D channels in arbitrary order. The number of elements defines the number of A/D channels used.

For example, to use the first, second, and fifth channels, enter

[1,2,5]

Number the channels beginning with 1 even if this board manufacturer starts numbering the channels with 0.

Range vector

Enter a range code for each of the channels in the channel vector. The range vector must be the same length as the channel vector. This board allows the range of each channel to be different.

The following table is a list of the ranges for this driver and the corresponding range codes.

Input Range (V)	Range Code
-10 to +10	-10

Input Range (V)	Range Code
-5 to +5	-5
0 to +10	10

For example, if the first channel is -10 to +10 volts and the second channel is 0 to +10 volts, enter

[-10,10]

Gain vector

Enter 1, 2, 4, 8, 16, or 32 for each of the channels in the channel vector to choose the gain code of that channel. The gain vector must be the same length as the channel vector. This driver allows the gain of each channel to be different.

The following table is a list of the ranges for this driver given the gain entered in the gain vector.

Gain	Range (V)
1	0 to +10
2	0 to +5
4	0 to +2.5
8	0 to +1.25
16	0 to +0.625
32	0 to +0.312

Notice that by increasing the gain code the voltage range is decreased. The gain divides the input voltage range.

For example, if the first channel has a gain code of 1 (10 volt range) and the second and fifth channels have a gain code of 2 (5 volt range), enter

[1,2,2]

Input coupling vector

Enter either 1 (ground-referenced single-ended (RSE)), 2 (nonreferenced singled-ended (NRSE)), or 3 (differential (DIFF)) for each of the channels in the channel vector to choose the coupling code. The coupling vector must be the same length as the channel vector. This driver allows the coupling of each channel to be different.

The following table is a list of the couplings for this driver and the corresponding coupling codes.

Coupling	Coupling Code	Description
RSE	1	High side of input signal connected to the selected analog input channel. Low side of input signal connected to one of the analog ground (ANALOG GND) pins. See the board manual.
NRSE	2	High side of input signal connected to the selected analog input channel. Low side of the input signal connected to the analog input sense (AINSENSE) pin at the I/O connector. See the board manual.
DIFF	3	High side of input signal connected to the selected analog input channel AIN1+...AIN8+. Low side of input signal connected to AIN- pin corresponding to the AIN+. See the board manual.

For example, if the first and second channels are ground referenced single-ended and the third channel is a differential input, enter

```
[1,1,3]
```

For differential inputs, the driver selects a second differential input that is eight channels higher than the first channel. In the example above, the driver selects the eleventh channel (AIN11/AIN3-) as a differential input.

Sample time

Enter the base sample time or a multiple of the base sample time (- 1 means sample time is inherited).

PCI slot (-1:autosearch)

If only one board of this type is in the target computer, enter - 1 to locate the board.

If two or more boards of this type are in the target computer, enter the bus number and the PCI slot number of the board associated with this driver block. Use the format **[BusNumber,SlotNumber]**.

To determine the bus number and the PCI slot number, type:

```
tg = slrt;
getPCIInfo(tg, 'installed')
```

Real Time Devices DM7420 Digital Input

DM7420 Digital Input block (not recommended)

Library

Simulink Real-Time Library of Drivers No Longer Recommended for Use

Block Parameters

Channel vector

Enter numbers between 1 and 8 to select the digital input lines used with this port. This driver allows the selection of individual digital input lines in arbitrary order. The number of elements defines the number of digital lines used.

For example, to use all of the digital inputs for one port, enter

```
[1,2,3,4,5,6,7,8]
```

Number the lines beginning with 1 even if this board manufacturer starts numbering the lines with 0.

Port

From the list choose either 0 or 1

Sample time

Enter the base sample time or a multiple of the base sample time (-1 means sample time is inherited).

PCI slot (-1:autosearch)

If only one board of this type is in the target computer, enter -1 to locate the board.

If two or more boards of this type are in the target computer, enter the bus number and the PCI slot number of the board associated with this driver block. Use the format **[BusNumber,SlotNumber]**.

To determine the bus number and the PCI slot number, type:

```
tg = slrt;
```

```
getPCIInfo(tg, 'installed')
```

Real Time Devices DM7420 Digital Output

DM7420 Digital Output block (not recommended)

Library

Simulink Real-Time Library of Drivers No Longer Recommended for Use

Block Parameters

Channel vector

Enter numbers between 1 and 8 to select the digital output lines used with this port. This driver allows the selection of individual digital output lines in arbitrary order. The number of elements defines the number of digital lines used.

For example, to use all of the digital outputs for one port, enter

```
[1,2,3,4,5,6,7,8]
```

Number the lines beginning with 1 even if this board manufacturer starts numbering the lines with 0.

Port

From the list choose either 0 or 1.

Sample time

Enter the base sample time or a multiple of the base sample time (-1 means sample time is inherited).

PCI slot (-1:autosearch)

If only one board of this type is in the target computer, enter -1 to locate the board.

If two or more boards of this type are in the target computer, enter the bus number and the PCI slot number of the board associated with this driver block. Use the format **[BusNumber,SlotNumber]**.

To determine the bus number and the PCI slot number, type:

```
tg = slrt;
```

```
getPCIInfo(tg, 'installed')
```

Texas Instruments Drivers No Longer Recommended for Use

Texas Instruments DM642 EVM

Evaluation Module for the Texas Instruments DM642 I/O board (not recommended)

TI DM642 Init

TI DM642 initialization block (not recommended)

TI DM642 RX

TI DM642 receive block (not recommended)

TI DM642 TX

TI DM642 transmit block (not recommended)

Texas Instruments DM642 EVM

Evaluation Module for the Texas Instruments DM642 I/O board (not recommended)

Board

Texas Instruments DM642 EVM

General Description

You can use the Simulink Real-Time and Texas Instruments DM642 Evaluation Module (EVM) with Simulink Real-Time and Simulink Coder to develop a hybrid system model. This enables you to build and download a real-time application to a target computer that contains a DM642 EVM board. This application can then communicate and exchange data with the DM642 EVM through a model that contains blocks that enable communication with the Simulink Real-Time software.

The Simulink Real-Time block library supports this board with these driver blocks:

- TI DM642 Init
- TI DM642 RX
- TI DM642 TX

To access these blocks, type `xpctexasinstrumentslib` at the MATLAB Command Window. If a Simulink Real-Time model includes a TI DM642 RX or TI DM642 TX block, you must include a TI DM642 Init block.

TI DM642 Init

TI DM642 initialization block (not recommended)

Library

Simulink Real-Time Library of Drivers No Longer Recommended for Use

Block Parameters

Page

Specify a value, in hex, for the page to write into the DSP page register. For example, to select the DM642 memory address 0x80000000, enter a value of 0x200. This is the default value.

Modify this value only if you want the DM642 to use a new value.

Note: This page must match the one accessed by the Embedded Coder model.

PCI slot (-1:autosearch)

If only one board of this type is in the target computer, enter -1 to locate the board.

If two or more boards of this type are in the target computer, enter the bus number and the PCI slot number of the board associated with this driver block. Use the format [**BusNumber**, **SlotNumber**].

To determine the bus number and the PCI slot number, type:

```
tg = slrt;  
getPCIInfo(tg, 'installed')
```

TI DM642 RX

TI DM642 receive block (not recommended)

Library

Simulink Real-Time Library of Drivers No Longer Recommended for Use

Block Parameters

Region

Enter a unique number (starting with 1) to identify the memory region for this block.

Note: Region numbers must be the same regions as those identified in the Embedded Coder DM642 model.

Data type and size (cell array)

Enter a cell array of character strings and port widths, in the form of `{'datatype[port width] '}`, for each port. Valid data types are:

- 'double'
- 'single'
- 'int8'
- 'uint8'
- 'int16'
- 'uint16'
- 'int32'
- 'uint32'
- 'boolean'

For example, a value of `{'double[1] '}` specifies a port data type of `double` and a width of 1.

New port

Select this check box to create an output port labeled **new**. This is a port of type **boolean** to indicate if the port data is new. This port does not indicate that data has changed, only that the DM642 has written data since the Simulink Real-Time software last read data. You might want to use this check box if this block is reading data asynchronously.

Block until data is available

Select this check box to read data only when data is ready to be read. The block is in a busy wait until then. Be careful to avoid deadlock situations when selecting this block.

Sample time

Enter the base sample time or a multiple of the base sample time (-1 means sample time is inherited).

PCI slot (-1:autosearch)

If only one board of this type is in the target computer, enter -1 to locate the board.

If two or more boards of this type are in the target computer, enter the bus number and the PCI slot number of the board associated with this driver block. Use the format **[BusNumber,SlotNumber]**.

To determine the bus number and the PCI slot number, type:

```
tg = slrt;  
getPCIInfo(tg, 'installed')
```

TI DM642 TX

TI DM642 transmit block (not recommended)

Library

Simulink Real-Time Library of Drivers No Longer Recommended for Use

Block Parameters

Region

Enter a unique number (starting with 1) to identify the memory region for this block.

Note: Region numbers must match the regions specified in the DM642 model.

Data type and size (cell array)

Enter a cell array of character strings and port widths, in the form of `{'datatype[port width] '}`, for each port. Valid data types are:

- 'double'
- 'single'
- 'int8'
- 'uint8'
- 'int16'
- 'uint16'
- 'int32'
- 'uint32'
- 'boolean'

For example, a value of `{'double[1] '}` specifies a port data type of `double` and a width of 1.

Block until data has been read

Select this box to write data only after the device has read existing data. The block is in a busy wait state until the data has been read. Be careful to avoid deadlock situations when selecting this block.

Sample time

Enter the base sample time or a multiple of the base sample time (- 1 means sample time is inherited).

PCI slot (-1:autosearch)

If only one board of this type is in the target computer, enter - 1 to locate the board.

If two or more boards of this type are in the target computer, enter the bus number and the PCI slot number of the board associated with this driver block. Use the format [**BusNumber,SlotNumber**].

To determine the bus number and the PCI slot number, type:

```
tg = slrt;  
getPCIInfo(tg, 'installed')
```

UDP Blocks No Longer Recommended for Use

These UDP blocks were used for legacy UDP. They are no longer recommended for use.

UDP Pack

Binary byte packing of input data into a single output vector (not recommended)

Library

Simulink Real-Time Library of Drivers No Longer Recommended for Use

Description

The Pack block is used to convert one or more Simulink signals of varying data types to a single vector of `uint8` as required by the Send block.

Note: The UDP Pack block will be removed in a future release. Use the Byte Packing block instead.

Block Parameters

Input port data types

Specify the data types for the different signals as part of the block parameters. The supported data types are `double`, `single`, `int8`, `uint8`, `int16`, `uint16`, `int32`, `uint32`, and `boolean`. The block determines the sizes of the signals automatically. This parameter is usually the same as the **Output port data types** parameter of the corresponding UDP Unpack block.

Byte alignment

The byte alignment field specifies how the data types are aligned. The possible values are: 1, 2, 4, and 8. The byte alignment scheme is simple, and starts each element in the list of signals on a boundary specified by the alignment relative to the start of the vector.

Example

The data types of each of the signals must be specified as a cell array of strings in the required order. Once this is done, the block automatically converts itself to one with the

corresponding number of input ports. There is one output port. For example, say the input port data types are specified as

```
{'uint8','uint32','single','int16','double'}
```

and an alignment of 4 is used. Assume also that the signals are scalars. The first signal then starts at byte 0, the second at byte 4, the third at byte 8, the fourth at byte 12, and the fifth at byte 16. Note that the sizes of the data types used in this example are 1, 4, 4, 2, and 8 bytes respectively. This implies that there are “holes” of 3 bytes between the first and second signal and 2 bytes between the fourth and fifth signal.

A byte alignment of 1 means the tightest possible packing. That is, there are no holes for arbitrary combinations of signals and data types.

Note: Individual elements of vector/matrix signals are not byte aligned; only the entire vector/matrix is byte aligned. The individual elements are tightly packed with respect to the first element.

See Also

UDP Unpack

UDP Send

UDP Unpack

Unpack a binary byte vector to extract data (not recommended)

Library

Simulink Real-Time Library of Drivers No Longer Recommended for Use

Description

This block is the exact analog of the Pack block. It receives a vector of `uint8` and outputs various Simulink data types in different sizes. The Pack block is on the sending side and the Unpack block is on the receiving side in different models.

Note: The UDP Unpack block will be removed in a future release. Use the **Byte Unpacking** block instead.

Block Parameters

Output port dimensions

Contains a cell array, with each element the dimension returned by the MATLAB size function of the corresponding signal. This should normally be the same as the dimensions of the signals feeding into the corresponding Pack block.

Output port data types

Specify the data types for the different signals as part of the block parameters. The supported data types are `double`, `single`, `int8`, `uint8`, `int16`, `uint16`, `int32`, `uint32`, and `boolean`. This parameter is usually the same as the **Input port data types** parameter of the corresponding UDP Pack block.

Byte alignment

The byte alignment field specifies how the data types are aligned. The possible values are: 1, 2, 4, and 8. The byte alignment scheme is simple, and starts each element in the list of signals on a boundary specified by the alignment relative to the start of the vector.

Byte Alignment

The byte-alignment feature provided in the Pack and Unpack blocks is primarily intended for interfacing a system running the Simulink Real-Time software to another system running neither Simulink nor Simulink Real-Time software. For example, the data on the other end might be in the form of a C `struct`, which is subject to the byte-alignment convention of the compiler used. You should use a byte-alignment value of 1 (tightly packed) if the source and target data formats permit it. (This is easily accomplished when UDP I/O is used to exchange data between two Simulink Real-Time systems or between Simulink Real-Time and Simulink systems.)

Even when communication is between the Simulink Real-Time system and a system using a C `struct`, the use of compiler preprocessor directives might help to pack the structure tightly. For example, `#pragma pack(1)` is common to several compilers. The byte-alignment blocks are provided for cases when this is not possible.

Utility Blocks No Longer Recommended for Use

These utility blocks were used for digital I/O. They are no longer recommended for use.

Digital I/O Bit-Packing

Construct data frames (not recommended)

Digital I/O Bit-Unpacking

Extract data frames (not recommended)

Digital I/O Bit-Packing

Construct data frames (not recommended)

Library

Simulink Real-Time Library of Drivers No Longer Recommended for Use

Description

This block constructs data frames. Its output port is typically connected to an input port of a digital I/O block. The block has one output port of data type `uint32` (a scalar), which represents the data frame entity constructed by the signals entering the block at its input ports. The number of input ports depends on the setting in the block's dialog box. See *CAN Bit-Packing* for an example of how to use a bit-packing block.

Block Parameters

Bit Patterns

Specify bit patterns. The data type entered in the control must be a MATLAB cell array vector. The number of elements in the cell array define the number of input ports shown by this block instance. The cell array elements must be of type double array and define the position of each bit of the incoming value (data typed input port) in the outgoing `uint32` value (data frame).

From a data type perspective (input ports), the block behaves like a Simulink Sink block. Therefore, the data types of the input ports are inherited from the driving blocks.

This block inherits the sample time of the driving blocks.

See Also

Digital I/O Bit-Unpacking

Digital I/O Bit-Unpacking

Extract data frames (not recommended)

Library

Simulink Real-Time Library of Drivers No Longer Recommended for Use

Description

This block is used to extract data frames. Its input port is typically connected to an output port of a digital I/O block. The block has one input port of data type `uint32` (a scalar), which represents the data frame entity from which the signals are extracted and leaving the block at its output ports. The number of output ports and the data type of each output port depend on the settings in the block's dialog box. See [CAN Bit-Unpacking](#) for an example of how to use a bit-unpacking block.

Block Parameters

Bit Patterns

Lets you define the bit patterns in a flexible way. The data type entered in the field must be a MATLAB cell array vector. The number of elements in the cell array define the number of output ports shown by this block instance. The cell array elements must be of type double array and define the position of each bit of the incoming value (data typed output port) in the incoming `uint32` value (data frame).

Sign extend

Select this check box to enable sign extension. If you select this check box and unpack the data frame into a signed type (`int8`, `int16`, or `int32`), the block performs sign extension. For example, if the bit pattern is `[0:4]`, and the data type is `int8`, you are extracting 5 bits into an 8-bit wide signed type. In this case, bits 5, 6, and 7 are the same as bit 4, resulting in sign extension. This functionality enables you to pack and unpack negative numbers without losing precision. In the example from [CAN Bit-Unpacking](#), you can pack and unpack numbers in the range `[-16 : 15]` (a fictitious `int5` type).

Data Types

From a data type perspective (output ports), the block behaves like a Simulink Source block. Therefore, the data types of the output ports must be defined in this field. The data type entered must be a MATLAB cell array vector of the same length as the bit pattern cell array. The cell array elements must be of type `char` and define the data type of the corresponding output port. The following values are supported:

- `boolean`
- `int8`
- `uint8`
- `int16`
- `uint16`
- `int32`
- `uint32`

This block inherits the sample time of the driving blocks.

See Also

Digital I/O Bit-Packing

XCP Drivers No Longer Recommended for Use

The following blocks are intended to support XCP over CAN. They are no longer recommended for use.

XCP Protocol Stack

XCP Protocol Stack block (not recommended)

XCP DAQSTIM

XCP DAQSTIM block (not recommended)

XCP Protocol Stack

XCP Protocol Stack block (not recommended)

Library

Simulink Real-Time Library of Drivers No Longer Recommended for Use

Description

The XCP Protocol Stack block implements the transportation layer for the communication between the target computer and the CAN network. It also initializes ECUs on CAN networks. Use one XCP Protocol Stack block for each CAN channel.

Block Parameters

Protocol Stack ID

Enter the identifier for the XCP protocol stack. This value must match the value of the **Stack ID** parameter in the corresponding XCP DAQSTIM block.

CAN TX Port

From the list, select the index of the CAN transmit port.

CAN Rx Port

From the list, select the index of the CAN receive port.

Max CAN Frame Tx (Per sample time)

Enter the maximum number of frames the real-time application can transmit per sample time.

Max CAN Frame Rx (Per Sample time)

Enter the maximum number of frames the real-time application can receive per sample time.

Sample time

Enter the base sample time or a multiple of the base sample time (-1 means sample time is inherited).

See Also

XCP DAQSTIM

XCP DAQSTIM

XCP DAQSTIM block (not recommended)

Library

Simulink Real-Time Library of Drivers No Longer Recommended for Use

Description

The XCP DAQSTIM block manages the synchronous data communication with an XCP slave running on the CAN network. This block supports:

- Data acquisition — Data flows from the ECU that supports the XCP slave to the master.
- Data stimulation — Data flows from the master to the ECU that supports the XCP slave.

The block dialog box supports configuration of the dynamic data acquisition list with a selection tool. As you configure the block, the block inputs and outputs change correspondingly.

- 1 Specify an ECU configuration A2L file (ASAP2 database) in the **Main A2L File** parameter.
- 2 Specify an XCP slave configuration A2L file (ASAP2 database) in the **XCP A2L File** parameter.
- 3 Observe that the block populates the **Events** and **Signals** parameters with the contents of the two A2L files.
- 4 Use the add and remove buttons on the selection tool to move event channels into a configuration. Assign signals to those channels for the configuration.

Block Parameters

Events

The software populates this field with event channels based on the contents of the files you specify in **Main A2L File** and **XCP A2L File**. Select the event channel to associate with the periodic data acquisition and stimulation of signals. You can configure multiple event channels to obtain different rates of triggering for the provided signal acquisition or stimulation events.

The event channel names clearly indicate:

- Data flow direction (data acquisition or data stimulation)
- Slave-side event type, such as the data flow rate

Signals

The software populates this field based on the contents of the files you specify in **Main A2L File** and **XCP A2L File**.

Configuration

Use the add and remove buttons to move signals and events into configurations for the slave ECU.

Main A2L File

Specify the A2L file that describes the available measurement and characteristics. The block maps the selected measurements as signals.

XCP A2L File

Specify the A2L file that describes a slave that supports XCP. The file contains the IF_DATA settings of the A2L database.

Slave ID

Enter the identifier for the slave ECU you are configuring.

Stack ID

Enter the stack identifier for the slave ECU you are configuring. This value must match the value of the **Protocol Stack ID** parameter in the corresponding XCP Protocol Stack block.

See Also

XCP Protocol Stack

